

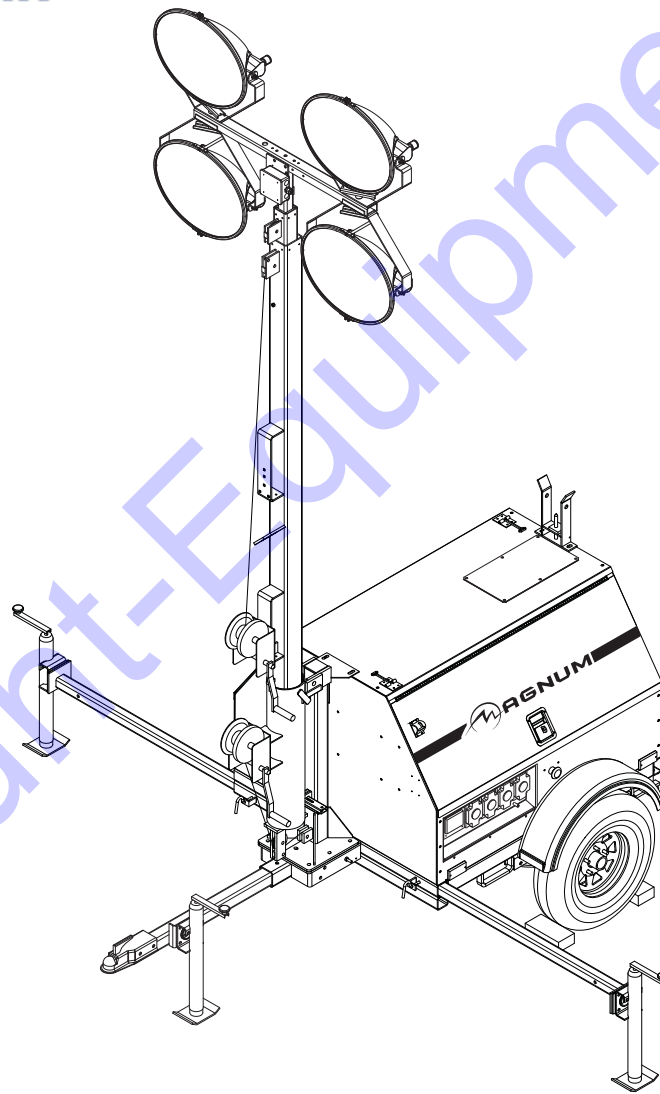

MLT 4250



www.discount-equipment.com



OPERATING/PARTS MANUAL

Discount Equipment

Discount-Equipment.com is your online resource for commercial and industrial quality parts and equipment sales.

Locations:

Florida (West Palm Beach): [561-964-4949](tel:561-964-4949)

Outside Florida TOLL FREE: [877-690-3101](tel:877-690-3101)

Need parts? Check out our website at www.discount-equipment.com

Can't find what you need?

Click on this link: <http://www.discount-equipment.com/category/5443-parts/> and fill out the request form.

Please have the machine model and serial number available in order to help us get you the correct parts. One of our experienced staff members will get back to you with a quote for the right part that your machine needs.

We sell worldwide for the brands: Genie, Terex, JLG, MultiQuip, Mayco, Toro/Stone, Diamond Products, Magnum, Airman, Mustang, Power Blanket, Nifty Lift, Atlas Copco, Chicago Pneumatic, Allmand Brothers, Essick, Miller Spreader, Skyjack, Lull, Skytrak, Tsurumi, Husquvarna/Target, Whiteman-Concrete/Mortar, Stow-Concrete/Mortar, Baldor, Wacker, Sakai, Snorkel, Upright, Mi-T-M, Sullair, Neal, Basic, Dynapac, MBW, Weber, Bartell, Bennar Newman, Haulotte, Ditch Runner, Blaw-Knox, Himoina, Best, Buddy, Crown, Edco, Wyco, Bomag, Laymor, Terremite, Barreto, EZ Trench, Takeuchi, Basic, Bil-Jax, Curtis, Gehl, Heli, Honda, ICS/PowerGrit, Puckett, Waldon, ASV, IHI, Partner, Imer, Clipper, MMD, Koshin, Rice, Gorman Rupp, CH&E, Cat Pumps, Comet, General Pump, Giant, AMida, Coleman, NAC, Gradall, Square Shooter, Kent, Stanley, Tamco, Toku, Hatz, Kohler, Robin, Wisconsin, Northrock, Oztec, Toker TK, Rol-Air, Small Line, Wanco, Yanmar

New Equipment - Used Equipment - Rental Equipment - Parts and Accessories

Discount Equipment

www.discount-equipment.com

561-964-4949

Sales: info@Discount-Equipment.com

Parts: wbparts@Discount-Equipment.com

INTRODUCTION

This manual provides information and procedures to safely operate and maintain the light tower and generator. For your own safety and protection from physical injury, carefully read, understand, and observe the safety instructions described in this manual. *The information contained in this manual was based on machines in production at the time of publication. Magnum Products LLC reserves the right to change any portion of this information without notice.*

DO NOT MODIFY or use this equipment for any application other than which it was designed for.

Magnum Products LLC recommends that a trained and licensed professional perform all electrical wiring and testing functions. Any wiring should be in compliance with the United States National Electric Code (NEC), state and local codes and Occupational Safety and Health Association (OSHA) guidelines.

Engine Make: _____

Engine Serial Number: _____

Engine Model Number: _____

Generator Make: _____

Generator Model Number: _____

Generator Serial Number: _____

Unit Model Number: _____

Unit Serial Number: _____

▲ WARNING

CALIFORNIA PROPOSITION 65 WARNING:

Diesel engine exhaust and some of its constituents are known to the state of California to cause cancer, birth defects and other reproductive harm.

TABLE OF CONTENTS

	Page
INTRODUCTION	2
TABLE OF CONTENTS	3
SAFETY NOTES	4
OPERATING SAFETY	4
ENGINE SAFETY	5
SERVICE SAFETY	5
TOWING SAFETY	6
REPORTING TRAILER SAFETY DEFECTS	6
UNIT SERIAL NUMBER LOCATIONS	6
SAFETY SYMBOL SUMMARY	7
SPECIFICATIONS	8 - 9
EXTERIOR LOCATIONS	10
MAIN CONTROL PANEL COMPONENTS	11
MAGNUM DIGITAL CONTROLLER (MDC)	12 - 13
GENERATOR MONITORING	13
ENGINE MONITORING	14 - 15
FINE VOLTAGE ADJUSTMENT	15
MDC CONTROLLER INFORMATION DISPLAYS, FUNCTIONS AND RESET	16
MDC CONTROLLER - GENERATOR OPERATIONAL STATUS	16
MDC CONTROLLER - ALARM MANAGEMENT	16
MDC CONTROLLER LIST OF POSSIBLE ALARMS WITH DESCRIPTIONS	17 - 18
MDC CONTROLLER - HISTORY	18
ADJUSTING THE DISPLAY BACKLIGHTING	19
RESETTING THE "TIME TO SERVICE" REMINDER	19
GENERATOR OUTPUT CONNECTION LUGS	20
VOLTAGE SELECTOR SWITCH	21
AUXILIARY OUTLETS	22
VOLTAGE REGULATION	22
EMERGENCY STOP SWITCH	22
MAIN CIRCUIT BREAKER	23
REMOTE START TERMINAL BLOCK	23
TRANSFER SWITCH	23 - 24
LIGHT TOWER SET-UP	25
RAISING THE TOWER	26
RAISING THE TOWER WITH OPTIONAL ELECTRIC WINCH	27
LIGHT TOWER START UP	28
PRE-START CHECKLIST	28
MANUAL STARTING OF THE GENERATOR	28 - 30
AUTO (REMOTE) STARTING OF THE GENERATOR	30
LIGHT OPERATION	31
SHUTTING DOWN THE GENERATOR	31
LOWERING THE TOWER	32
LOWERING THE TOWER WITH OPTIONAL ELECTRIC WINCH	32
REMOVING THE LIGHTS FOR TRANSPORTATION	33
TOWING THE TRAILER	33
TRAILER WHEEL BEARINGS	33
LIFTING THE TRAILER	34
GENERAL MAINTENANCE	34
ENGINE MAINTENANCE	35
OPTIONAL LOWER RADIATOR HOSE HEATER USE AND MAINTENANCE	35
DERATING FOR ALTITUDE	36
TROUBLESHOOTING SHUTDOWN CONDITIONS	36
TROUBLESHOOTING THE LIGHTS	37
UNIT DECALS	38 - 41
MANUAL WINCH MAST ASSEMBLY	42 - 43
ELECTRIC WINCH MAST ASSEMBLY	44 - 45
FRAME AND COMPONENTS	46 - 48
GENERATOR ASSEMBLY	49
MAST JUNCTION BOX ASSEMBLY - HARD WIRED LIGHTS	50
MAST JUNCTION BOX ASSEMBLY - QUICK DISCONNECT LIGHTS	51
ENCLOSURE ASSEMBLY	52 - 53
AUXILIARY OUTLET PANEL ASSEMBLY	54 - 55
AUXILIARY OUTLET PANEL OPTIONS	56 - 57
LIGHT ASSEMBLY	58 - 59
ENGINE COOLING ASSEMBLY	60 - 61
ENGINE ASSEMBLY	62 - 63
CONTROL PANEL ASSEMBLY	64 - 65
CONTROL BOX ASSEMBLY	66 - 67
LUG DOOR ASSEMBLY	68
WIRING DIAGRAMS	69 - 75

SAFETY NOTES



This is the safety alert symbol. It is used to alert you to potential personal injury hazards. Obey all safety messages that follow this symbol to avoid possible injury or death.

This manual contains DANGERS, WARNINGS, CAUTIONS, NOTICES and NOTES which must be followed to prevent the possibility of improper service, damage to the equipment, personal injury or death. The following formatting options will apply when calling the readers attention to the DANGERS, WARNINGS, CAUTIONS, NOTICES and NOTES.

▲ DANGER

INDICATES A HAZARDOUS SITUATION WHICH, IF NOT AVOIDED, WILL RESULT IN DEATH OR SERIOUS INJURY.

▲ WARNING

Indicates a hazardous situation which, if not avoided, could result in death or serious injury.

▲ CAUTION

Indicates a hazardous situation which, if not avoided, may result in minor or moderate injury.

NOTICE

Indicates a hazardous situation which, if not avoided, may result in property or equipment damage.

Note: Notes contain additional information important to a procedure and will be found within the regular text body of this manual.

OPERATING SAFETY



Before using the light tower be sure you read and understand all of the instructions! This equipment was designed for specific applications; **DO NOT** modify or use this equipment for any application other than which it was designed for. Equipment operated improperly or by untrained personnel can be dangerous! Read the operating instructions and familiarize yourself with the location and proper use of all instruments and controls. Inexperienced operators should receive instruction from someone familiar with the equipment before being allowed to operate or set up the light tower. The following points should be practiced at all times:

- The area immediately surrounding the light tower should be dry, clean, and free of debris.
- Position and operate the light tower on a firm, level surface.
- **NEVER** start a unit in need of repair.
- Lower tower when not in use, or if high winds or electrical storms are expected in the area.
- Make certain light tower is well grounded and securely fastened to a good earthen ground.
- The tower extends up to 30 ft. (9m). Make sure area above trailer is open and clear of overhead wires and obstructions.
- Bulbs become extremely hot in use! Allow bulb and light fixture to cool 10-15 minutes before handling.
- Keep area behind trailer clear of people while raising and lowering mast!
- **NEVER** raise, lower or turn mast while unit is operating!
- Trailer must be leveled and outriggers extended before raising tower. Outriggers must remain extended while tower is up.
- If for any reason any part of mast hangs up or winch cable develops slack while raising or lowering tower, **STOP** immediately! Contact an authorized service representative.
- **NEVER** remove safety pin or pull mast locking pin while tower is up!
- **NEVER** use tower if insulation on electrical cord is cut or worn through.
- **NEVER** operate lights without protective lens cover in place or with a lens cover that is cracked or damaged!

ENGINE SAFETY



Internal combustion engines present special hazards during operation and fueling! Failure to follow the safety guidelines described below could result in severe injury or death. Also read and follow all safety warnings described in the Engine Operator's Manual. A copy of this manual was supplied with unit when it was shipped from the factory.

- **DO NOT** run engine indoors or in an area with poor ventilation unless exhaust hoses are used. Diesel engine exhaust contains carbon monoxide, a deadly, odorless and colorless gas which, if inhaled, can cause nausea, fainting or death. Make sure engine exhaust cannot seep into closed rooms or ventilation equipment.
- **DO NOT** fill fuel tank near an open flame, while smoking, or while engine is running. **DO NOT** fill tank in an enclosed area with poor ventilation.
- **DO NOT** operate with the fuel tank cap loose or missing.
- **DO NOT** touch or lean against hot exhaust pipes or engine cylinders.
- **DO NOT** clean air filter with gasoline or other types of low flash point solvents.
- **DO NOT** remove engine coolant cap while engine is hot.
- **DO NOT** operate the unit without a functional exhaust system. Prolonged exposure to sound levels in excess of 85 DBA can cause permanent hearing loss. Wear hearing protection when working around a running engine.
- Keep area around exhaust pipes and air ducts free of debris to reduce the chance of an accidental fire.
- Batteries contain sulfuric acid which can cause severe injury or death. Sulfuric acid can cause eye damage, burn flesh or eat holes in clothing. Protective eye wear and clothing are necessary when working on or around the battery. Always disconnect the **NEGATIVE (-)** battery cable from the corresponding terminal before performing any service on the engine or other components.
- Shut the engine down if any of the following conditions exist during operation:
 1. Noticeable change in engine speed.
 2. Loss of electrical output.
 3. Equipment connected to the generator overheats.
 4. Sparking occurs.
 5. Engine misfires or there is excessive engine/generator vibration.
 6. Operating on a combustible surface.
 7. Protective covers are loose or missing.
 8. If the ambient air temperature is above 110° F.

SERVICE SAFETY



This unit uses high voltage circuits capable of causing serious injury or death. Only a qualified electrician should troubleshoot or repair electrical problems occurring in this equipment.

- Before servicing light tower, make sure the engine start switch is turned to OFF, circuit breakers are open (off) and the negative terminal on the battery is disconnected. **NEVER** perform even routine service (oil/filter changes, cleaning, etc.) unless all electrical components are shut down.
- **NEVER** allow water to accumulate around the base of the light tower. If water is present, **DO NOT** service!
- **NEVER** service electrical components if clothing or skin is wet. If the unit is stored outside, check the engine and generator for any moisture and dry the unit before use.
- **NEVER** wash the unit with a power washer or high pressure hose.
- Open main circuit breaker before disconnecting battery cables.
- Keep hands, feet, and loose clothing away from moving parts on generator and engine.
- Make sure slings, chains, hooks, ramps, jacks, and other types of lifting devices are attached securely and have enough weight-bearing capacity to lift or hold the equipment safely. Always remain aware of the position of other people around you when lifting the equipment.

TOWING SAFETY



Towing a trailer requires care! Both the trailer and vehicle must be in good condition and securely fastened to each other to reduce the possibility of an accident. Also, some states require that large trailers be registered and licensed. Contact your local Department of Transportation office to check on license requirements for your particular unit.

- Check that the hitch and coupling on the towing vehicle are rated equal to, or greater than, the trailer's "gross vehicle weight rating" (GVWR).
- Check tires on trailer for tread wear, inflation, and condition.
- Inspect the hitch and coupling for wear or damage. **DO NOT** tow trailer using defective parts!
- Make sure the trailer hitch and the coupling are compatible. Make sure the coupling is securely fastened to the vehicle.
- Connect safety chains in a crossing pattern under the tongue and attach the breakaway cable **TO THE REAR BUMPER OF THE TOWING VEHICLE**. Do not attach the cable to the trailer hitch.
- Make sure directional and brake lights on the trailer are connected and working properly.
- Check that all lug nuts holding wheels on are tight and that none are missing.
- Maximum recommended speed for highway towing is 45 m.p.h. Recommended off-road towing speed is not to exceed 10 m.p.h. or less depending on terrain.

When towing, maintain extra space between vehicles and avoid soft shoulders, curbs and sudden lane changes. If you have not pulled a trailer before, practice turning, stopping, and backing up in an area away from heavy traffic.

A film of grease on the coupler will extend coupler life and eliminate squeaking. Wipe the coupler clean and apply fresh grease each time the trailer is towed.

REPORTING TRAILER SAFETY DEFECTS

If you believe your trailer has a defect which could cause a crash or could cause injury or death, you should immediately inform the National Highway Traffic Safety Administration (NHTSA) in addition to notifying Magnum Products LLC. If NHTSA receives similar complaints, it may open an investigation; and if it finds that a safety defect exists in a group of vehicles, it may order a recall and remedy campaign. However, NHTSA cannot become involved in individual problem between you, your dealer, or Magnum Products LLC.

To contact NHTSA, you may either call the Auto Safety Hotline toll-free at 1-888-327-4236 or by fax at: (202)-366-7882. Additional contact information can be found at: www.nhtsa.dot.gov.

UNIT SERIAL NUMBER LOCATIONS

Refer to the locations illustrated below to find the unit ID tag, and trailer ID tag on your unit. Important information, such as the unit serial number, model number and Vehicle Identification Number (V.I.N.) for your trailer are found on these tags. Record the information from these tags, so it is available if the tags are lost or damaged. When ordering parts or requesting technical service information, you may be asked to specify this information.

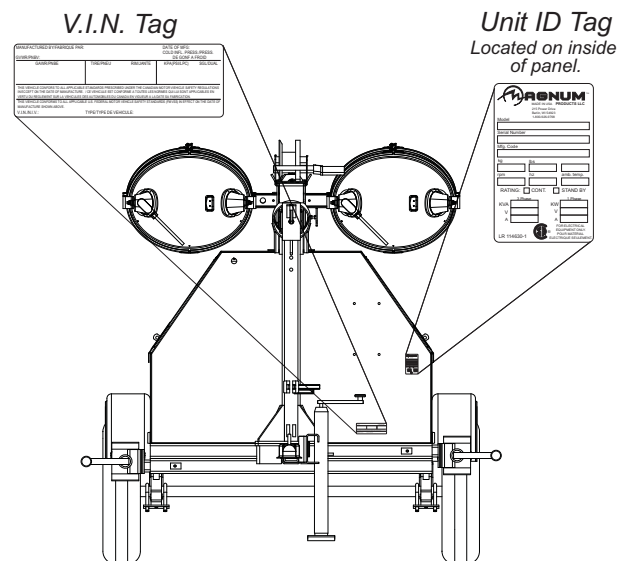

SAFETY SYMBOL SUMMARY

This equipment has been supplied with numerous safety and operating decals. These decals provide important operating instructions and warn of dangers and hazards. Replace any missing or hard-to-read decals and use care when washing or cleaning the unit. Decal placement and part numbers can be found in the beginning of the parts section of this manual. Below is a summary of the intended meanings for the symbols used on the decals.

	Safety alert symbol; Used to alert you to potential personal injury hazards.		Asphyxiation hazard; Operate in well ventilated area.
	Hot surface(s) nearby.		Dangerous voltage may be present.
	Belt/entanglement hazard; Keep body parts clear of this area.		Anchor/tie down point.
	Fan hazard; Keep body parts clear of this area.		Forklift here only.
	Crush hazard; Keep body parts clear of this area.		Use clean diesel fuel only.
	Ultraviolet radiation hazard; Operate only with lens intact.		Burn/scald hazard; pressurized steam.
	Stop engine before fueling.		Read and understand the supplied operator's manual before operating unit.
	Fire/explosion hazard; Keep open flames away from unit.		Unit electrical ground.
	Lift here only.		

SPECIFICATIONS

Read this manual carefully before attempting to use this light tower. The potential for property damage, personal injury or death exists if this equipment is misused or installed incorrectly. Read all of the manuals included with this unit. Each manual details specific information regarding items such as set up, use and service requirements. Specifications are subject to change without notice.

MAGNUM MODEL

MLT 4250

Engine

Make/Brand	Isuzu
Model	4LE1-NYGV-01
Type	Diesel, liquid cooled, 4-stroke
Horsepower - prime hp (kW)	31.5 (23.5)
Horsepower - standby hp (kW)	34.5 (25.7)
Operating Speed rpm	1800
Displacement in³ (L)	134.25 (2.20)
Cylinders - qty	4
Fuel Consumption - 100% prime gph (Lph)	1.80 (6.81)
Battery Type - Group Number	24
Battery Voltage (Quantity per Unit)	12V (1)
Battery Rating	720 CCA

Generator

Make/Brand	Marathon Electric
Model	282NSL1505
Type, Insulation	Brushless, H

Generator Set (Engine/Generator)

3Ø - Standby kW (kVA)	20 (25)
Amps - 3Ø Standby - 480 (208V) A	30 (69)
3Ø - Prime kW (kVA)	18 (23)
Amps - 3Ø Prime - 480 (208V) A	28 (64)
1Ø - Standby - kW (kVA)	16.0 (16.0)
Amps - 1Ø Standby - 240V A	67
1Ø - Prime - kW (kVA)	15.0 (15.0)
Amps - 1Ø Prime - 240V A	63
Frequency Hz	60
Power Factor	1 (1Ø), 0.8 (3Ø)

Dimensions

Length w/ mast stowed in (m)	170 (4.32)
Width in (m)	63 (1.60)
Width w/ outriggers extended in (m)	140 (3.56)
Height w/ mast stowed in (m)	70 (1.78)
Maximum height of tower ft (m)	30 (9.14)

Weights

Dry Weight lbs (kg)	2158 (979)
Operating Weight lbs (kg)	2556 (1159)

Capacities

Fuel Tank Volume gal (L)	56 (212)
Usable Fuel Volume gal (L)	56 (212)
Coolant (incl. engine) qt (L)	11.6 (11.0)
Oil (incl. filter) qt (L)	8.6 (8.1)
Maximum Run Time hrs	31

SPECIFICATIONS

Read this manual carefully before attempting to use this light tower. The potential for property damage, personal injury or death exists if this equipment is misused or installed incorrectly. Read all of the manuals included with this unit. Each manual details specific information regarding items such as set up, use and service requirements. Specifications are subject to change without notice.

Lighting

Lighting Type	Metal Halide
Ballast Type	Coil & Core
Lumens	440,000
Coverage acres (m²)	5 - 7 (20,234 - 28,328)

AC Distribution

Circuit Breaker Size	90
Voltage Selection	3 Position Switch (lockable)
Voltage Regulation	+/-1%
Voltages Available 1Ø	120, 139, 208, 220, 240, 277
Voltages Available 3Ø	208, 220, 440, 480

Trailer

Number of Axles	1
Capacity - Axle Rating lbs (kg)	3000 (1361)
Tire Size in	15
Hitch - Standard	2" Ball
Maximum Tire Pressure psi	50

EXTERIOR LOCATIONS

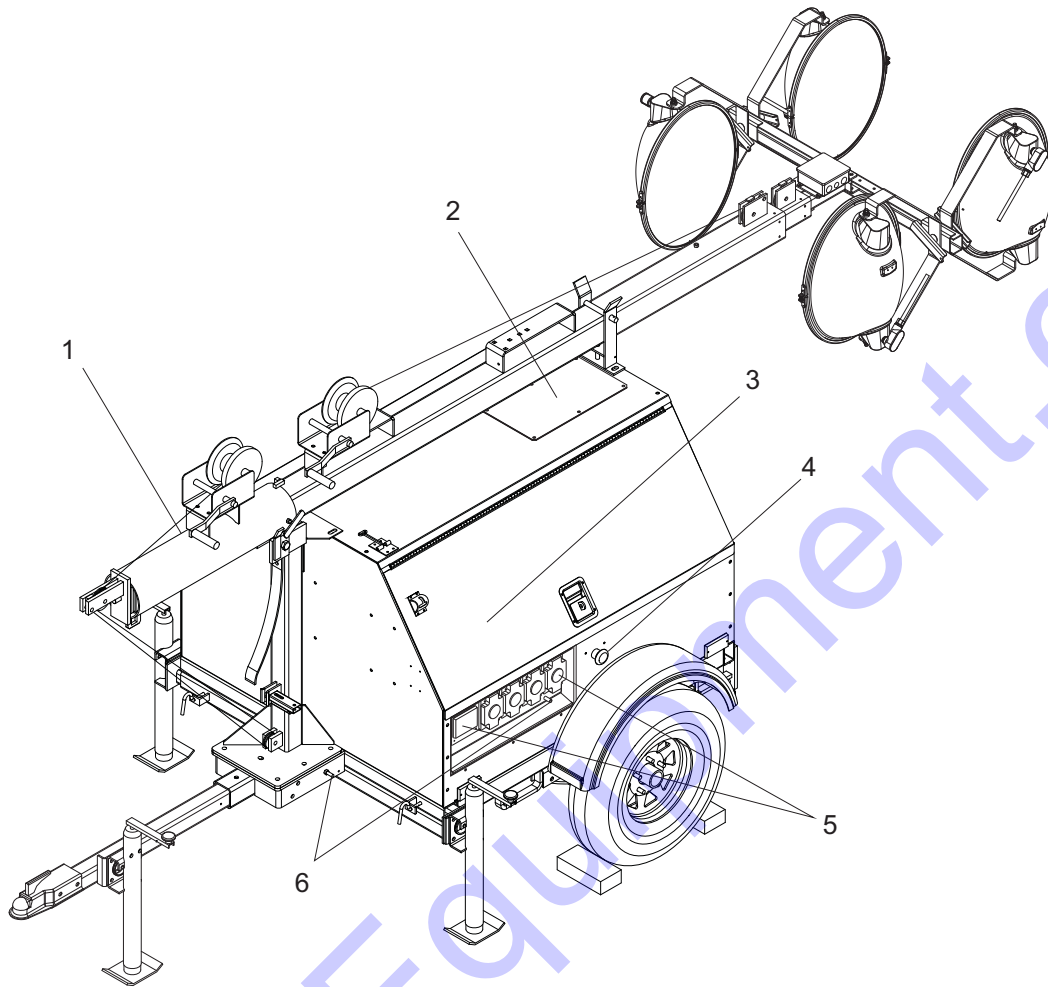

1. **FUEL FILLER LOCATION (under door):** Use clean **DIESEL FUEL ONLY**.
2. **RADIATOR ACCESS PANEL:** Remove this panel for engine coolant service.
3. **CONTROL PANEL LOCATION (under door):** Engine/generator controls and all circuit breakers.
4. **EMERGENCY STOP SWITCH:** For emergency shutdown; stops engine and trips main circuit breaker.
5. **EQUIPMENT OUTLETS:** Circuit breaker protected outlets; 20, 30 and/or 50 amp ratings.
6. **GROUND STUDS (2):** For grounding generator and equipment connected to the equipment outlets.

MAIN CONTROL PANEL COMPONENTS

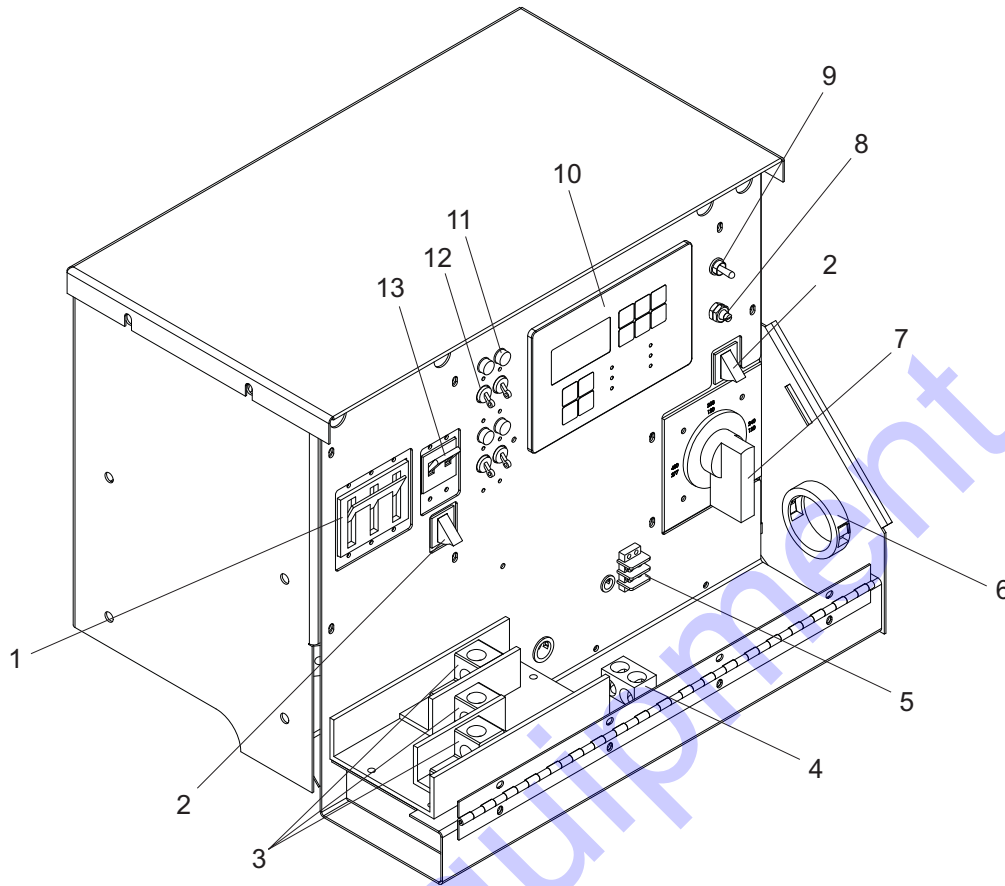

1. **MAIN CIRCUIT BREAKER (90A):** This breaker will disconnect power to the connection lugs.
2. **LUG DOOR SAFETY SWITCHES:** These switches will shut the generator down if the lug door is opened when the generator is running.
3. **GENERATOR OUTPUT CONNECTION LUGS:** These allow appropriate loads to be wired directly to the generator.
4. **GENERATOR GROUND CONNECTION LUG:** This lug is for connecting a good earthen ground per any local, state or National Electric Code (NEC) guidelines before starting the generator.
5. **REMOTE START TERMINAL BLOCK:** Allows connections for remote starting of the generator.
6. **CABLE ACCESS:** Allows for entry of load cables to the connection lugs with the lug box door closed.
7. **PHASE SELECTOR SWITCH:** This switch will change the generator output between three phase and single phase power. See the VOLTAGE SELECTOR SWITCH section for more information.
8. **VOLTAGE ADJUSTMENT RHEOSTAT:** Used to fine tune generator output voltage.
9. **CONTROL POWER SWITCH:** This is the main power switch for the controller in MANUAL or AUTO mode.
10. **ENGINE CONTROL PANEL:** See pages 12 - 13 for additional information.
11. **BALLAST INDICATOR LIGHTS:** Indicates power from the ballast to each light.
12. **INDIVIDUAL CIRCUIT BREAKERS:** One breaker is supplied for each light.
13. **AUXILIARY OUTLET MAIN CIRCUIT BREAKER (100A):** This breaker disconnects power to the auxiliary equipment outlets.

MAGNUM DIGITAL CONTROLLER (MDC)

The Magnum Digital Controller (MDC) is an enhanced digital generator controller used to start, stop and monitor the operation of the generator and the engine. The controller constantly monitors vital generator and engine functions for a number of pre-programmed alarm and fault conditions. When a fault condition occurs, the engine will shut down automatically and the Liquid Crystal Display (LCD) window will display the fault that caused the shutdown; to resume operation the fault condition must be resolved. The controller has the ability to provide the display readout in English and Spanish; other languages are available. A screen print out of the display screen is also available. This controller also records a “History” of the unit’s performance which may be viewed at any time and will not be removed or lost when the controller is powered down.

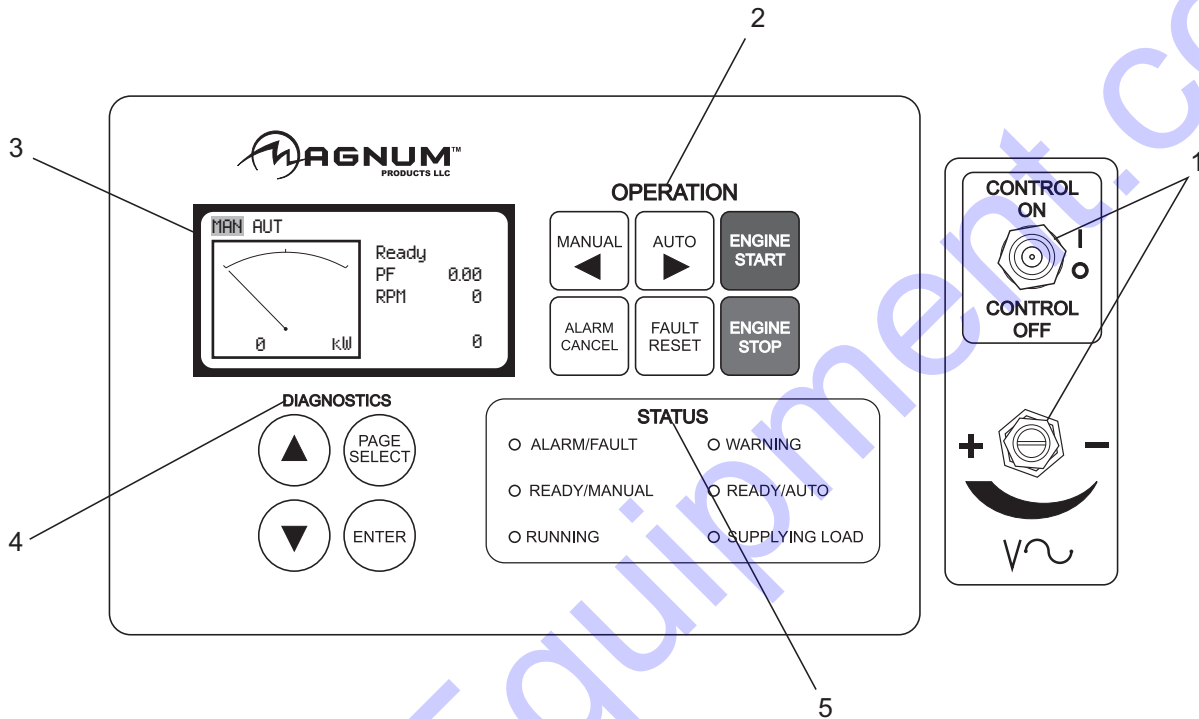

The MDC panel consists of five sections, including: the “CONTROL ON” / “CONTROL OFF” Toggle Switch and Fine Voltage Adjustment Screw; the “OPERATION” keypad; the LCD window; the “DIAGNOSTICS” keypad; and the “STATUS” Light Emitting Diodes (LED’s). The following is a brief summary of the operation of each section of the control panel:

1. The “CONTROL ON” / “CONTROL OFF” Toggle Switch and Fine Voltage Adjustment Screw

- Control On/Off Toggle Switch
This toggle switch powers-up the control panel and the controller.
- Fine Voltage Adjustment Screw
This screw may be adjusted to set the generator output voltage after the voltage selector switch has been changed from one phase to another. This adjustment must be accomplished within 45 seconds of start-up so that the unit does not experience a shut down alarm for “SENSING”.

2. The “OPERATION” Keypad

- “ENGINE START” Button
The Power Screen Display must be in the “MAN” mode in the upper left corner of the LCD window and the “Ready/Manual” LED lit in the “Status” portion of the controller. Press the green “ENGINE START” button to start the unit.
- “ENGINE STOP” Button
Press the red “ENGINE STOP” button to shut down the unit and start the “Stop Value” timer.
- “MANUAL ◀” Button
Press this button to change from the Automatic (Remote) starting mode to Manual starting mode.
- “AUTO ▶” Button
Press this button to change from Manual starting mode to Automatic (remote) starting mode.

- “ALARM CANCEL” Button
When an alarm is activated, either visually or audibly, press this button to silence or cancel the alarm.
- “FAULT RESET” Button
Press this button to clear the fault from the LCD window after the fault has been corrected.
Press “FAULT RESET” and “ENTER” to clear the John Deere ECU Alarm List Codes.

3. The Liquid Crystal Display (LCD)

- This window will toggle between the Generator Display Screen and the Engine Display Screen upon start-up of the unit. By viewing these screens, the operator will be able to monitor both the engine and generator status while the unit is running.

4. The “DIAGNOSTICS” Keypad

- “▲” Scroll-Up Button
Press this button to scroll-up within the LCD window.
- “▼” Scroll-Down Button
Press this button to scroll-down within the LCD window.
- “PAGE SELECT” Button
Pressing this button will select the next display screen.
- “ENTER” Button
Pressing this button will place you inside the particular display to review the generators preprogrammed setpoints or parameters.

5. The “STATUS” Light Emitting Diodes (LED’s)

- These 6 LED’s will illuminate to display the current operational status of the generator;
 - Alarm/Fault: Indicates active or inactive alarms, but not reset shutdown alarms.
 - Warning: Indicates an active or inactive alarm, or a warning alarm that has not been reset
 - Ready/Manual: Indicates the controller is ready to start and in the manual mode.
 - Ready/Auto: Indicates the unit is in the “AUTO” mode ready for the remote start signal.
 - Running: Indicates the unit is running.
 - Supplying Load: Indicates a load is being applied to the generator.

GENERATOR MONITORING

Generator information is shown on the Liquid Crystal Display (LCD) window in a toggling manner with the Engine information after the first 60 seconds of operation, then every five seconds thereafter. The generator display screen will show frequency, line to neutral voltage, line to line voltage and amperage.

Note: When loading the generator, it is important to observe the amperage to determine the load balance on each line of the generator. Minor load unbalances, usually 5% or less, will not cause any particular problems. Every effort should be made to distribute the load equally between all lines.

- **Hertz:** Displays output frequency.
- **Generator Output Voltage:** Line to Neutral display, single phase (1Ø).
- **Generator Output Voltage:** Line to Line display, 3 phase (3Ø).
- **Amps:** Displays the AC output amperage produced by the generator.

GENERATOR DISPLAY SCREEN

Gen freq	60.0Hz		
L1N	120V	L12	208V
L2N	120V	L23	208V
L3N	120V	L31	208V
A	226	222	223

ENGINE DISPLAY SCREEN

Oil Press	49 psi
Engine Temp	183°F
Fuel Level	83%
Vbat	13.4V

ENGINE MONITORING

Engine information is shown on the Liquid Crystal Display (LCD) window in a toggling manner with the Generator information after the first 60 seconds of operation and then every 5 seconds thereafter. The engine display screen will show oil pressure, engine coolant temperature, fuel level and battery voltage.

- **Oil Press:** Displays engine oil pressure. The display registers oil pressure between 0-100 psi. Normal operating pressure is between 35-80 psi.
- **Eng Temp:** Displays the temperature of the engine's coolant. If the coolant temperature exceeds the Maximum Water Temperature of 230° F the engine will automatically shut down. Zero "0" will be displayed until a minimum temperature of 100° F is reached.
- **Fuel Level:** Displays the relative fuel level in the fuel tank in percent (50% = 1/2 tank, 75% = 3/4 tank, etc.). If the fuel level drops below a programmed low fuel point – usually at 15%, a low fuel warning and optional audio alarm will be activated. If the fuel level drops below the programmed low fuel limit, usually at 5%, the engine will automatically shut down. (Note: The MLG 25 does not display fuel level).
- **Vbat:** Displays the engine battery voltage. A normal reading is 13-14V on 12 volt systems and 24-26 on 24 volt systems, (with the engine running).

Additional information may be viewed while the unit is in "MANUAL" or "AUTO" mode. By pressing the "Page Select" button, the operator will select one of the following screens; "Running" screen, "Password" screen, or "History" screen. In each of these page selections the operator may press the "▲" or "▼" buttons on the "DIAG-NOSTICS" keypad to display additional information as follows:

- **"Running" screen:**
The operator may press the "▲" or "▼" buttons on the "DIAGNOSTICS" keypad to display the "Alarm List" screen, "ECU Alarm List" screen, "Run Hours" screen, "ECU Values" screen, Engine display screen and Generator display screen.

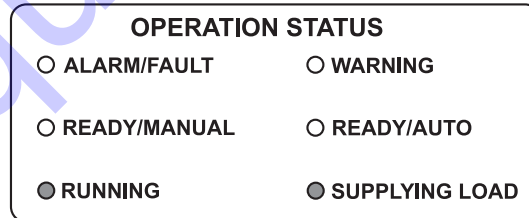
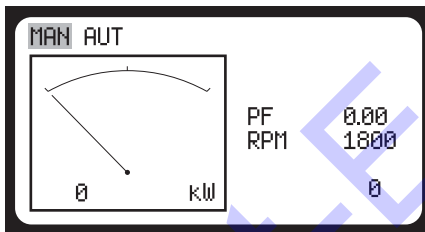

- **"Password" screen:**
The operator may press the "▲" or "▼" buttons on the "DIAGNOSTICS" keypad to move the ">" cursor up or down a list of text.

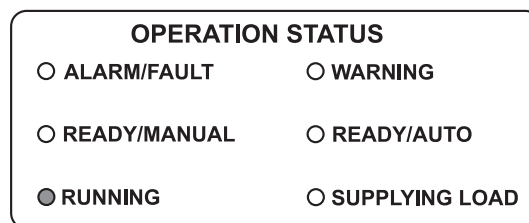
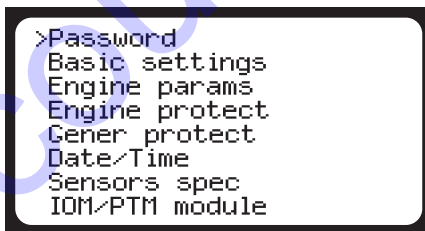

- **"History" screen:**
The operator may press the "▲" or "▼" buttons on the "DIAGNOSTICS" keypad to move the ">" cursor up or down a list of the latest alarm or shutdown codes. Pressing the "Enter" button at a particular selection will allow the operator to scroll to the right in the LCD window to view the generator operating parameters at the time of the alarm or shutdown.

The history of alarms or codes of the unit are saved in the digital controller. The most recent alarm or code is the first to be listed, with the time/date of the alarm or code at the bottom of the screen. The controller stores up to 118 codes. When full, the controller will automatically remove the oldest file. These codes will not be lost when the control power toggle switch is powered off.

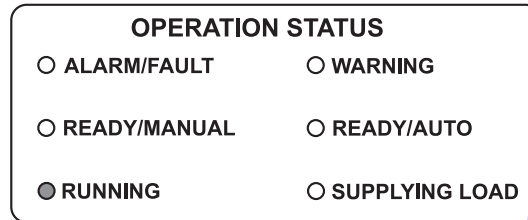
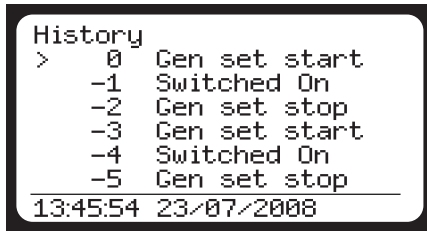

FINE VOLTAGE ADJUSTMENT

Upon start-up of the generator, the “Running” screen of the Magnum Digital Controller (MDC) will display “SENSING” and will countdown from 45 seconds to “0” Zero. This is a safety feature of the controller to protect the generator from over or under voltage upon start-up.

“SENSING” is a 45 second time delay and count down process before the MDC records the generator nominal output voltage. This nominal generator voltage is then compared to the current set point voltage of the voltage selector switch. If the nominal voltage recorded by the controller is greater than or lower than the current set point voltage of the voltage selector switch setting by 10% or more, the controller will shut the generator down automatically. The display will read: Wrn VG1 or 2 or 3 Under/Over and/or Sd Vg1 or 2 or 3 Under/Over. This means the controller warned (“Wrn”) or even shut down (“Sd”) the unit due to an output voltage irregularity.

VOLTAGE
ADJUSTMENT
RHEOSTAT

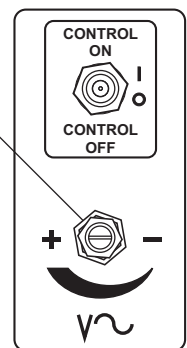

The output voltage of the generator may be adjusted after the generator is running by use of the fine voltage adjustment screw. The adjusting screw is located directly below the control On/Off toggle switch on the control panel. This screw turns a rheostat that will provide an increase (“+”) or a decrease (“-”) in the generator output voltage as displayed on the Power Display Screen on the control panel. When making this adjustment, if the voltage is increased or decreased too fast or too slow, the unit will automatically shut down. This adjustment needs to be made within the 45 second delay and countdown to “0” Zero period.

To adjust the output voltage, check the output voltage on the Liquid Crystal Display (LCD) window labeled Gen freq & Hz. Look at the L1N voltage or the L12 voltage on the display. The generator nominal output voltage should be within 10% of the voltage rating on the voltage selector switch.

To adjust the output voltage loosen the lock nut at the base of the screw and turn the screw in the desired direction until the required voltage shown on the LCD window matches the stated voltage on the voltage selector switch.

For Example: With the voltage selector switch set to “208/120V” 3 Phase position, the voltage displayed on the Gen freq & Hz screen must be within $\pm 10\%$ of the 208/120 position (188-228 V Line to Line / 108-132 V Line to Neutral).

If the voltage is not set within 10% of the applied voltage or the voltage is not reset within the 45 second delay period, the generator will shut down automatically and the display will read Wn VG1 or 2 or 3 Under/Over and/or Sd Vg1 or 2 or 3 Under/Over.

Note: Each time the voltage selector switch is changed from one setting to another, an adjustment will need to be made to the fine voltage using this adjustment screw.

MAGNUM DIGITAL CONTROLLER (MDC) INFORMATION DISPLAYS, FUNCTIONS AND RESET

The Magnum Digital Controller (MDC) constantly monitors vital generator and engine functions for a number of operation, alarm and fault conditions. When a fault condition occurs, the engine will shut down automatically and the Liquid Crystal Display (LCD) window will show the fault that has caused the shut down. To resume operation, the fault condition must be resolved. To reset the controller and resume operation, press the "FAULT RESET" button.

MAGNUM DIGITAL CONTROLLER (MDC) – GENERATOR OPERATIONAL STATUS

The Magnum Digital Controller (MDC) displays the operational status of the generator using the following codes:

No.	Engine State Machine	Description
1	AfterCool	Engine aftercooling, Cooling Pump output is closed.
2	Cooling	The generator is cooling before stop.
3	Cranking	Engine is cranking.
4	EmergMan	Emergency Manual gen-set operation.
5	Init	Autotest during controller power on.
6	Loaded	The generator is running at nominal speed and GCB OPEN/CLOSE is closed.
7	Not Ready	The generator is not ready to start.
8	Pause	Pause between start attempts.
9	Prestart	Prestart sequence in process, Prestart output is closed.
10	Ready	The generator is ready to run.
11	Running	The generator is running at nominal speed.
12	Shutdown	Shut-down alarm is activated.
13	Starting	Starting speed is reached and the <i>Idle timer</i> is running.
14	Stop	Stop
No.	Electrical State Machine	Description
1	StabilTO	Stabilization Timeout

MAGNUM DIGITAL CONTROLLER (MDC) - ALARM MANAGEMENT

The Magnum Digital Controller (MDC) is capable of displaying the following alarms:

No.	Type	Description
1	Sensor fail (FLS)	Sensor fail is detected when measured value is 6% out of the selected characteristic. Sensor fail indicated by ##### symbol instead measured value.
2	Warning (WRN)	When warning comes up, see list of possible alarms.
3	Shut down (SD)	When the shut-down alarm comes up the Magnum Digital Controller opens outputs GCB CLOSE/OPEN, FUEL, SOLENOID, STARTER AND PRESTART to stop the engine immediately.

MAGNUM DIGITAL CONTROLLER (MDC) - LIST OF POSSIBLE ALARMS/DESCRIPTIONS

Shut down and warning fault conditions and the displayed message are described in the following table:

No.	Events Specification	Protection Type	Information on Binary Output Available	Description
1	AnInIOM Sd	SD	YES	Shutdown alarm configurable on the input of IG-IOM/IGS-PTM.
2	AnInIOM Wrn	WRN	YES	Warning alarm configurable on the input of IG-IOM/IGS-PTM.
3	Battery Flat	SD	YES	If the controller switches off during starting sequence due to bad battery condition it doesn't try to start again and activates this protection.
4	Binary Input	Configurable	YES	Configurable Warning/Shutdown alarms on the inputs of IL-NT.
5	ChrgAlternFail	WRN	YES	Failure of the alternator for charging the battery.
6	EmergencyStop	SD	NO	If the input <i>Emergency stop</i> is opened shutdown is immediately activated.
7	Engine Temp Sd	SD	NO	Water temperature is greater than <i>Sd Water temp</i> setpoint.
8	Engine Temp Wrn	WRN	YES	Water temperature is greater than <i>Wrn Water temp</i> setpoint.
9	Fgen <, >	SD	YES	The generator frequency is out of limits given by <i>Gen >f</i> and <i>Gen <f</i> setpoints.
10	Fuel Level Sd	SD	YES	Fuel level is less than <i>Sd Fuel Level</i> setpoint.
11	Fuel Level Wrn	WRN	YES	Fuel level is less than <i>Wrn Fuel Level</i> setpoint.
12	GCB fail	SD	NO	Failure of the generator circuit breaker.
13	Igen unbl	SD	NO	The generator current is unbalanced.
14	Low BackupBatt	WRN	NO	RTC backup battery is flat.
15	Oil Press Sd	SD	NO	Oil pressure is less than <i>Sd Oil press</i> setpoint.
16	Oil Press Wrn	WRN	YES	Oil pressure is less than <i>Wrn Oil press</i> setpoint.
17	Overload	SD	YES	The load is greater than the value given by <i>Overload</i> setpoint.
18	Overspeed	SD	YES	The protection comes active if the speed is greater than <i>Overspeed</i> setpoint.
19	ParamFail	NONE	NO	Wrong checksum of parameters. Happens typically after downloading new firmware or changing of the parameter. The controller stays in INIT mode. Check all parameters write at least one new parameter.
20	PickupFault	SD	NO	Failure of the magnetic pick-up sensor for speed measurement.
21	Sd IOM fail	SD	NO	Shutdown alarm in case of lost connection to IG-IOM/IGS-PTM module.
22	SprinklActive	WRN	NO	The protection is active if the output <i>Sprinkler</i> is closed.
23	Start failed	SD	YES	Gen-set start failed
24	Stop fail	SD	YES	Gen-set stop failed.
25	Ubat	WRN	YES	Battery voltage is out of limits given by <i>Batt overvolt</i> and <i>Batt undervolt</i> setpoints.
26	Underspeed	SD	YES	During starting of the engine when the RPM reaches the value of <i>Starting RPM</i> setpoint the starter is switched off and the speed of the engine can drop under <i>Start RPM</i> again. Then the Underspeed protection becomes active. Protection evaluation starts 5 sec
27	Vgen <, >	SD	YES	The generator voltage is out of limits given by <i>Gen <V</i> and <i>Gen >V</i> setpoints.

28	Vgen unbal	SD	NO	The generator voltage is unbalanced more than the value of <i>Volt unbal</i> setpoint.
29	Wrn ECU Alarm	WRN	NO	ECU alarm list is not empty.
30	Wrn RA15 fail	WRN	NO	Warning alarm in case of lost connection to IGL-RA15 module.
31	WrnServiceTime	WRN	NO	The period for servicing is set by the <i>NextServTime</i> setpoint. The protection comes active if the running hours of the engine reach this value.

MAGNUM DIGITAL CONTROLLER (MDC) – HISTORY

The Magnum Digital Controller (MDC) controller stores a record of each important event into the history file of the controller. The history file seats 118 records. When the history file is full, the oldest records are removed.

No.	Record Structure Abbreviation	Historical value
1	AIM1	IG-IOM, IGS-PTM Analog input 1 value (when configured IG-IOM, IGS-PTM)
2	AIM2	IG-IOM, IGS-PTM Analog input 2 value (when configured IG-IOM, IGS-PTM)
3	AIM3	IG-IOM, IGS-PTM Analog input 3 value (when configured IG-IOM, IGS-PTM)
4	AIM4	IG-IOM, IGS-PTM Analog input 4 value (when configured IG-IOM, IGS-PTM)
5	BIM	IG-IOM, IGS-PTM Binary inputs (when configured IG-IOM, IGS-PTM)
6	BIN	Binary inputs IL-NT
7	BOM	IG-IOM, IGS-PTM Binary outputs (when configured IG-IOM, IGS-PTM)
8	BOUT	Binary inputs IL-NT
9	Date	Date of historical event in format DD/MM/YY
10	EngT	IL-NT Analog input 2 value (default Water temperature)
11	FC	ECU alarm FailureCode
12	FLvl	IL-NT Analog input 3 value (default Fuel level)
13	FMI	ECUalarm Failure Mode Identifier
14	Gfrg	Generator frequency
15	Ig1	Generator current L1
16	Ig2	Generator current L2
17	Ig3	Generator current L3
18	LChr	Character of the load
19	Num	Number of historical event
20	OilP	IL-NT Analog input 1 value (default Oil pressure)
21	PF	Generator PF
22	Pwr	Generator active power
23	Reason	Event specification
24	RPM	Engine Speed
25	Time	Time of historical event in format HH:MM:SS
26	Ubat	Battery voltage
27	Vg1	Generator voltage L1
28	Vg2	Generator voltage L2
29	Vg3	Generator voltage L3

ADJUSTING THE DISPLAY BACK LIGHTING

The backlighting on the Liquid Crystal Display (LCD) window may be adjusted brighter or darker by the operator whenever the Magnum Digital Controller (MDC) is powered up.

1. Press and hold "Enter" and press "▲" or "▼" on the Diagnostics keypad to increase or decrease the display contrast as needed.
2. Release the "Enter" button and the "▲" or "▼" buttons when the desired backlighting is attained.

Note: Anytime an "*" is displayed on the LCD, the text or set point cannot be changed without the use of a password. Contact Magnum Products Technical Support for assistance.

RESETTING OF THE "TIME TO SERVICE" REMINDER

The Magnum Digital Controller (MDC) will display the message "WrnServiceTime" when the unit is due for maintenance or service. The maintenance or service interval is set at 250 hours of engine running time. Once the unit has been serviced, the "ServiceTime" reminder needs to be reset to the 250 hour interval. The following procedure demonstrates how to reset the running hours to 250:

1. With the unit shut down, power up the controller with the "Control On/Off" Toggle Switch. The initialization screen will be displayed. The controller will toggle automatically to the "Ready" Display screen.
2. Press the "▲" button. The "Alarm List" display screen will appear. The next screen will display lines of text; starting with the word "Password", then "Basic Settings", "Engine Params", "Engine Protect" etc. The top line has a ">" cursor before the word "Password".
3. Press the "▼" button to move the ">" cursor down to the "Engine Protect" line of text.
4. Press Enter. "NextServTime" will appear at the top of the display screen on the left side, with the current service time hour setting (250) one line below on the right side.
5. Press Enter. The current run time in hours will now appear on the left side of the display screen, directly under "NextServTime".
6. Press the "▲" button and reset the current run time hour setting to 250. If you overshoot the 250 time interval use the "▼" button to get back to the 250 time interval.
7. Press "Enter" to save the current run time hour setting.
8. Move the "CONTROL ON / I" toggle switch to the "CONTROL OFF / O" position.

GENERATOR OUTPUT CONNECTION LUGS

The generator is equipped with connection lugs behind a door below the controller face. The lugs provide connection points for attachment of external loads to the generator. A large decal on the inside of the connection lug door details the proper connections for selected voltages.

⚠ WARNING

It is **HIGHLY RECOMMENDED** that only a trained and licensed electrician perform any wiring and related connections to the generator. Installation should be in compliance with the National Electric Code (NEC) as well as any local or state guidelines as required by law. Failure to follow proper installation requirements may result in equipment or property damage, personal injury or death.

⚠ WARNING

Before any connections are made to the generator, make sure that the main circuit breaker and the control power switch are in the OFF "O" position. Potentially lethal voltages may be present at the generator connection lugs.

⚠ DANGER

IMPROPER OR INCORRECT CONNECTIONS TO A BUILDINGS ELECTRICAL SYSTEM CAN CAUSE POTENTIALLY LETHAL VOLTAGE TO BACKFEED ONTO UTILITY LINES. THIS MAY RESULT IN INJURY OR ELECTROCUTION TO UTILITY WORKERS NEARBY. MAKE SURE THE GENERATOR IS SUPPLYING POWER TO AN ISOLATED OBJECT OR BUILDING THAT IS NOT CONNECTED TO ANY UTILITY LINES.

Connections to the lugs should be made by running the power cables through the circular plastic bushing on the lower right side of the control box. **DO NOT** make any connections directly to the lugs without routing the cables through this bushing. The lug door is equipped with safety interlock switches that will automatically trip the main circuit breaker and disable the voltage regulator when the lug door is opened. Use a hex-wrench to tighten the cable connections.

⚠ WARNING

Never attempt to disable or modify the lug door safety switches. Equipment damage, personal injury or death may result.

A ground connection is located next to the connection lugs. The unit **MUST HAVE** this ground lug connected to a good earthen ground for proper operating safety. The ground connection should be in compliance with the National Electric Code (NEC) as well as any state or local guidelines or codes.

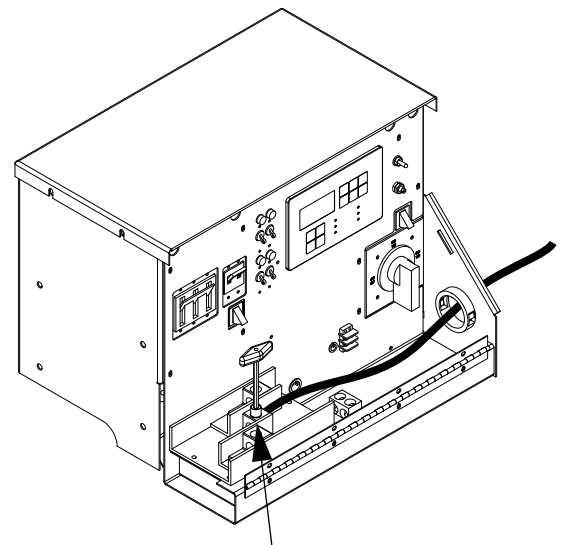

TIGHTEN CONNECTION LUGS WITH A HEX WRENCH

VOLTAGE SELECTOR SWITCH

The voltage selector switch is located behind the lug door, underneath the engine controller panel. The selector switch is a three position switch that mechanically changes the connections between the generator output leads and the connection lugs. Voltage ranges are selected by rotating the handle on the switch to the desired voltage.

NOTICE

Never change the voltage selector switch while the engine is running!
This will cause sever arcing and damage to the switch and generator windings.

480/277V
3-PHASE

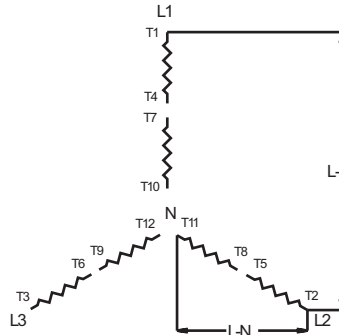
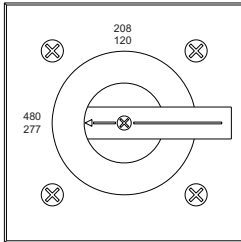

L1 - L2 = 480V L1 - N = 277V
L2 - L3 = 480V L2 - N = 277V
L3 - L1 = 480V L3 - N = 277V
N = \perp

208/120V
3-PHASE

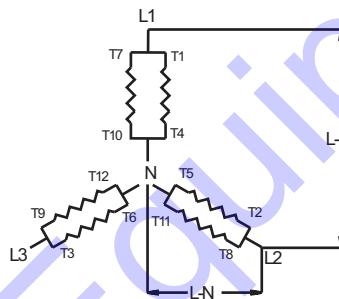
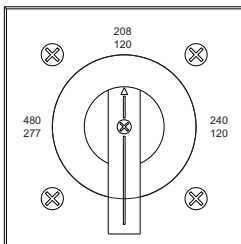

L1 - L2 = 208V L1 - N = 120V
L2 - L3 = 208V L2 - N = 120V
L3 - L1 = 208V L3 - N = 120V
N = \perp

240/120V
1-PHASE

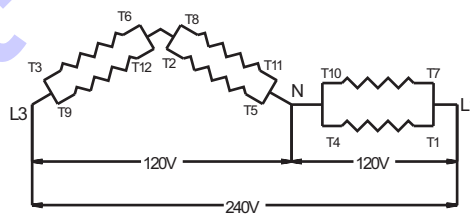
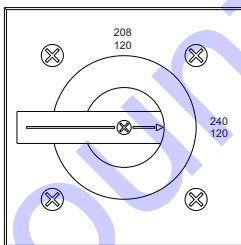

L1 - L3 = 240V L2 - N = -----
L1 - N = 120V L3 - N = 120V

The voltage switch is equipped with a locking mechanism. Once the proper voltage has been selected, push the red latch on the inside of the phase switch handle up and insert a padlock through the handle. By locking the handle in place you will prevent unauthorized personnel from changing the switch settings.

Note: When the voltage selector switch is in position for 480/277V 3Ø, voltage at the two GFCI duplex convenience outlets is 139 Volts and the voltage at the three twist-lock outlets is 240/139 Volts. When the voltage selector switch is in position for 208/120V 3Ø, voltage at the three twist-lock outlets and the two GFCI outlets is 208/120 Volts.

AUXILIARY OUTLETS

The control panel is equipped with six outlets for running accessories or tools from the generator. Power is supplied to the outlets any time the engine is running and the main circuit breaker and the auxiliary outlet main circuit breaker are switched in the ON "I" position.

Should the main breaker trip, or the auxiliary outlet main circuit breaker trip, remove some of the load to the outlets before turning them back on.

Note: To ensure proper grounding, anytime the generator is providing power to any equipment or load panels that do not have a grounded plug, a ground wire **must be** added between the equipment and the grounding stud on the outlet panel per any local, state or NEC codes and guidelines.

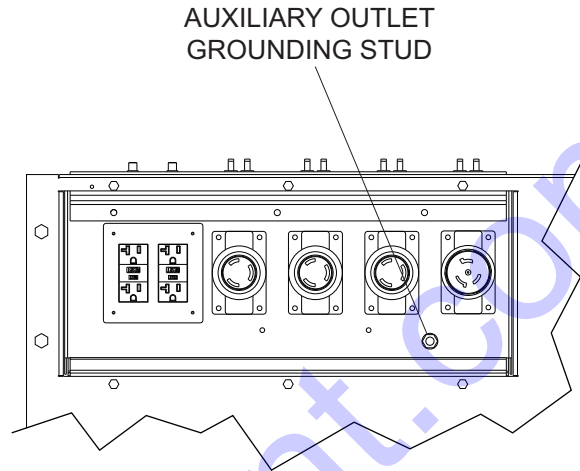

VOLTAGE REGULATION

The electronic voltage regulator controls the output of the generator by regulating the current into the exciter field. The regulator has three screwdriver adjustable potentiometers that may be adjusted for voltage, stability and under frequency (U/F). The voltage regulator on your unit is adjusted before shipment from the factory. Contact Magnum Products LLC for additional information before attempting to adjust the voltage regulator.

EMERGENCY STOP SWITCH

The generator is equipped with one emergency stop switch, located on the side panel next to the auxiliary outlet panel. The switch is clearly labeled with "EMERGENCY STOP" and is red in color. The switch can be accessed and activated with all doors closed and locked.

Activate the emergency stop switch by pushing the red button in until it locks down. This will trip the main circuit breaker which will open the contact disconnecting the load to the connection lugs. This will also open the fuel circuit, shutting down the engine and the Emergency Stop fault will be displayed on the LCD. The switch will remain closed until it is pulled out. **Note:** Use the EMERGENCY STOP only when the generator must be shut down immediately. For any other shut down, follow the detailed shut down procedure.

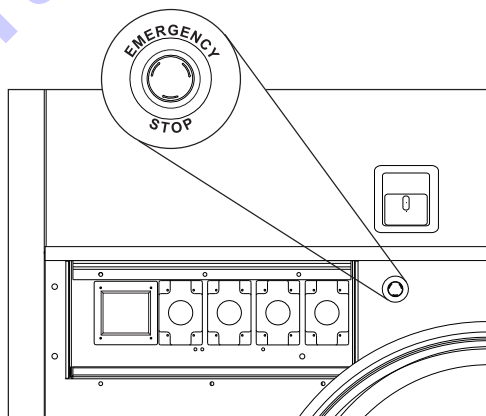

MAIN CIRCUIT BREAKER

The main circuit breaker is located on the main control panel. When the breaker is in the OFF “O” position, power is interrupted between the customer connection lugs and the generator. Once the connections have been made to the connection lugs and the generator has been started and allowed to reach normal operating temperature, the breaker may be switched to the ON “I” position.

The main circuit breaker will be tripped, disconnecting power to the connection lugs, if any of the following items occur while the unit is running:

1. Overload of the generator circuits to the connection lugs.
2. The lug box door covering the customer connection lugs is opened.
3. If the emergency stop switch is activated.

Make sure that any problems that caused the main circuit breaker to trip are corrected before returning the switch to the ON “I” position.

NOTICE

The main circuit breaker interrupts power to the customer connection lugs only. The customer convenience outlets have power even if the main circuit breaker is in the OFF “O” position. The auxiliary outlet main circuit breaker, located next to the main circuit breaker, will disconnect all power to the auxiliary outlet panel.

REMOTE START TERMINAL BLOCK

The remote start terminal block is located under the lug box door just below the voltage selector switch. It provides a connection for installation of a remote start switch which will allow the generator to be started by a remote dry-contact closure switch.

Before pressing the AUTO button, verify that the contacts on any remote switch linked to the generator are OPEN. If the contacts on a remote switch are closed, the generator will crank and start when AUTO is selected on the controller. Attach the switch leads to the two unused terminals on the generator's remote start block. For additional information on starting the generator, see the GENERATOR START UP section of this manual.

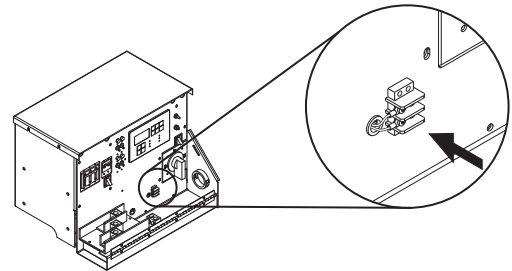

TRANSFER SWITCH

When the generator is used as a standby power supply, it must be equipped with a transfer switch which isolates it from the utility's distribution system. A transfer switch is designed to transfer electrical loads from the normal power source (utility) to the emergency power source (generator) when normal voltage falls below a prescribed level. The transfer switch automatically returns the load back to the normal source when power is restored back to operating levels.

⚠ DANGER

FAILURE TO ISOLATE THE GENERATOR FROM THE NORMAL POWER UTILITY CAN CAUSE POTENTIALLY LETHAL VOLTAGE TO BACKFEED INTO THE UTILITY LINES. THIS MAY RESULT IN INJURY OR ELECTROCUTION OF UTILITY WORKERS NEARBY. MAKE SURE THAT THE GENERATOR IS ISOLATED BY A TRANSFER SWITCH FROM ANY LOCAL UTILITY LINES. THIS ALSO APPLIES IF THE GENERATOR IS BEING USED AS A BACK UP TO SOME OTHER TYPE OF POWER SUPPLY.

Installation of a transfer switch or other type of remote starting device is the responsibility of the generator user. Installation of such devices must be performed by following all directions supplied by the manufacturer of the switch. If attaching generator to a power supply normally serviced by a utility company, notify the utility company and check local and state regulations. Familiarize yourself with all instructions and warning labels supplied with the switch.

⚠ WARNING

It is strongly recommended that **ONLY** a licensed electrician perform any wiring and any related connections to the generator. Installation should be in compliance of the National Electric Code as well as any state or local codes or regulations. Failure to follow these procedures could result in property damage, personal injury or death. Before any connections are attempted, make sure the main circuit breaker and the engine start switch are in the OFF "O" position and that the negative (-) battery cable has been disconnected from the engine starting battery.

NOTICE

When using the generator as a stand by or substitute power supply, make sure the output voltage and phase rotation of the generator match those of the local power utility. Improper voltage or phase rotation may cause equipment damage or malfunction.

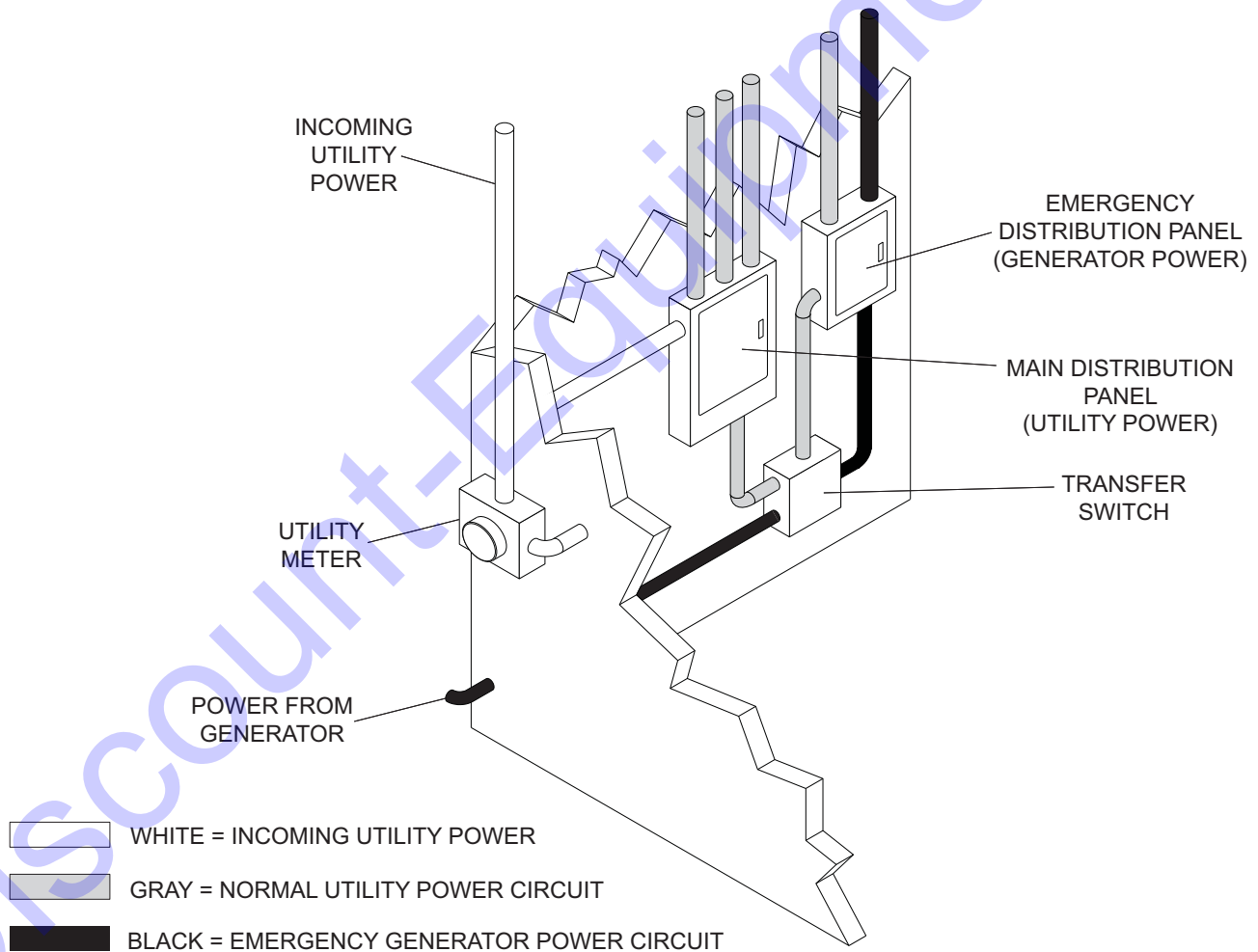

LIGHT TOWER SET-UP

1. For maximum light coverage locate tower at ground level or in a spot higher than the area being illuminated by the lamps.

⚠ WARNING

Check for any overhead obstructions such as utility lines or vegetation as the tower extends up to 30 ft. (9.14 m). Do not set up the tower if high winds or storms capable of producing lightning are expected in the area!

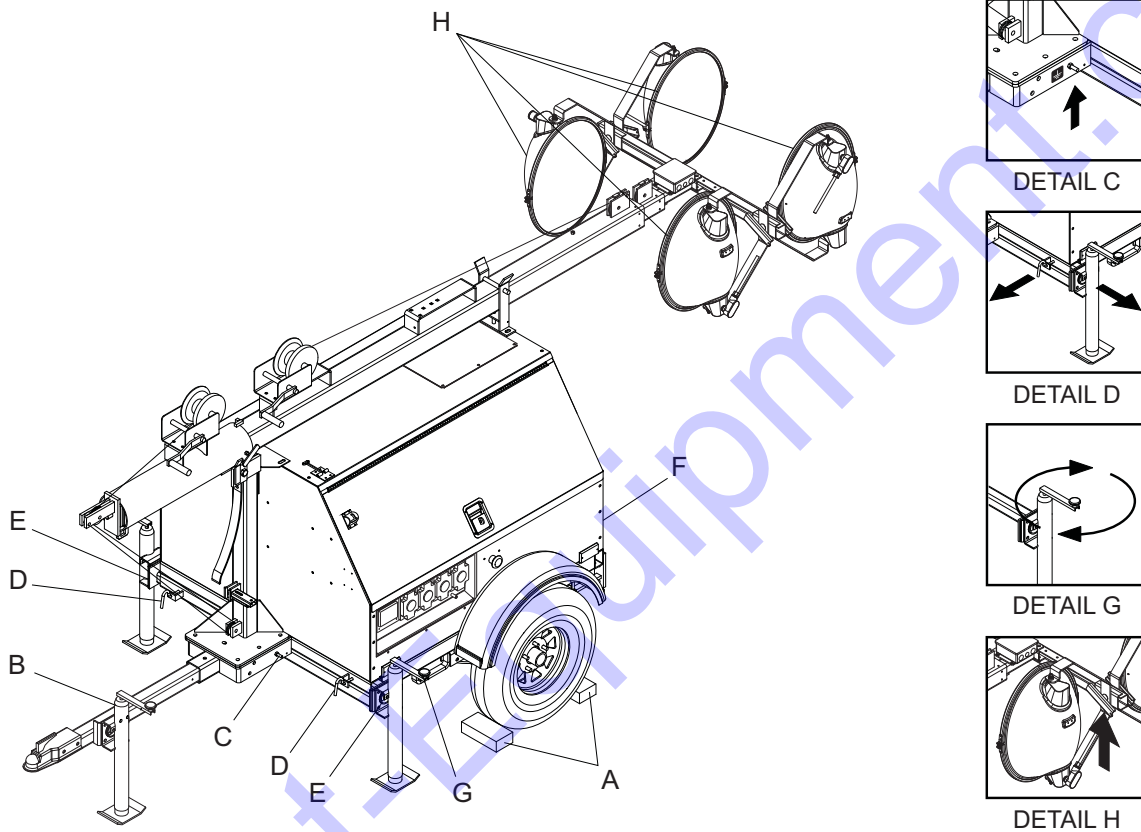

2. Place the trailer on firm ground that is relatively flat. This will make it easier to level the tower. Block the wheels on the trailer to keep it from moving (A).
3. Pull the locking pin on the tongue jack and rotate it 90° until the spring loaded pin snaps back into place (B). Turn the jack handle clockwise to raise the trailer tongue off of the towing vehicle.
4. Connect a good earthen ground to the grounding stud on the frame of the trailer near the trailer tongue (C).
5. Pull the locking pins (D) on the outriggers (E) and pull the outriggers out until the spring loaded locking pin snaps back into place. Pull the locking pin on the outrigger jacks and rotate them 90° until the spring loaded pin snaps back into place.
6. Pull the locking pin on the rear jack (F) and rotate it 90° until the spring loaded pin snaps back into place. Turn the jack handle clockwise to start leveling the trailer. Adjust all four jacks by turning their handles clockwise until they are firmly in contact with the ground and the trailer is as level as possible (G).
7. Before raising the tower it may be necessary to adjust the lamps. The lamps may be adjusted up, down, left or right by loosening the wing bolts on the lamp fixture (H) and aiming them in the desired direction. Tighten the hardware completely and make sure the lamps are connected to the junction box.

RAISING THE TOWER

⚠ WARNING

The trailer must be leveled with the outriggers extended before raising the tower. The outriggers must remain extended while the tower is up. Failure to level the trailer or extend the outriggers will severely reduce the stability of the unit and could allow the tower to tip and fall.

1. Remove the mast cradle locking pin from the mast cradle (I).
2. Check both sets of mast cables for excessive wear or damage. Make sure the cables are properly centered in each pulley (J). Check the electrical cord for damage.

⚠ WARNING

Do not start the unit if the insulation on the electrical cord is cut or worn through. Bare wires in contact with the mast or frame may energize the trailer and cause electrocution. Repair or replace cord.

3. Make sure the area behind the unit is clear before raising the mast to the vertical position.
4. Remove the safety pin (K) from the mast lock bar (L). Using the handle for the lower mast winch (M), raise the mast until it is vertical and the tab on the mast is positioned into the mast lock. The mast lock bar should snap into place automatically. Secure the lock with the safety pin (N).
5. After the mast is up and locked into place, use the upper mast winch (O) to telescope the tower to the desired height. Extend the mast slowly, making sure that the electrical cord is extending at the top sections of the mast. If, for any reason, the winch cable begins to develop slack or any of the tower sections get stuck, STOP IMMEDIATELY and contact an authorized service center.

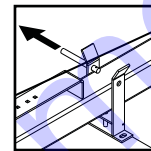

DETAIL I

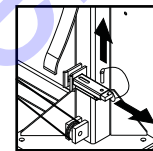

DETAIL K

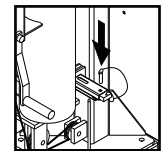

DETAIL N

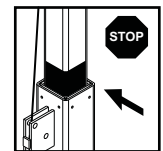

DETAIL P

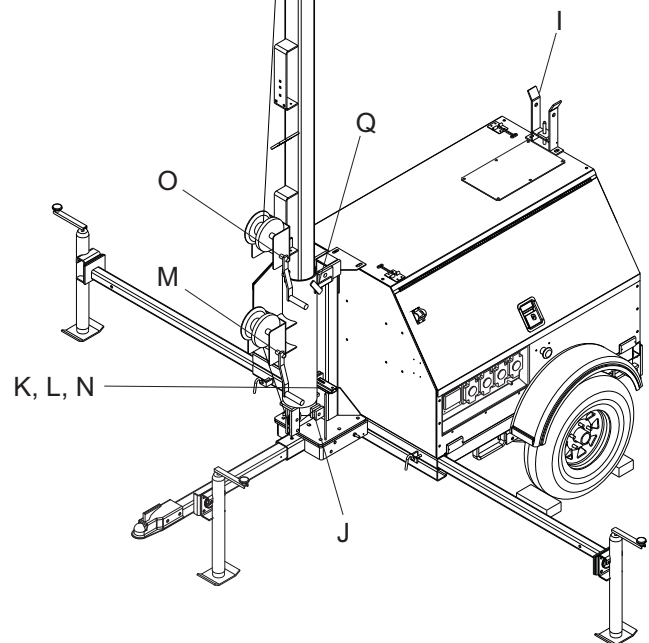

⚠ CAUTION

Do not extend the mast beyond the colored mark on the middle mast tube (P).

6. The mast can be rotated by loosening the locking knob at the bottom of the mast (Q). Turn the mast until the lights face in the desired direction and then tighten the knob.

⚠ WARNING

Never raise or lower the mast while the unit is operating! Never remove the safety pin or mast lock while the tower is up. Releasing the lock will cause the mast to fall.

RAISING THE TOWER WITH THE OPTIONAL ELECTRIC WINCH

1. Set up and level the trailer as described on page 25, and follow steps 1-3 on page 26.
2. Remove the safety pin from the mast lock bar (R).
3. Press the lower winch control toggle switch upward to raise mast into the vertical position (S). Hold switch until the mast lock is engaged. The mast lock bar should snap into place automatically. **Note:** On light towers equipped with the electric winch option, a limit switch on the mast tube will disconnect power to the lower electric winch to prevent deadheading the winch.
4. Secure the lock with the safety pin (T).
5. Press and hold the upper winch control toggle switch upward to telescope the mast to desired height (U). Extend the mast slowly, making sure that the coiled electrical cord is extending at the top sections of the mast. If, for any reason, the winch cable begins to develop slack or any of the tower sections get stuck, STOP IMMEDIATELY and contact an authorized service center.

⚠ CAUTION

Do not extend the mast beyond the colored mark on top of the lower mast section (V). On light towers equipped with the electric winch option, a limit switch on the main mast section will disconnect power to the upper electric winch to prevent over extending the mast.

6. The mast can be rotated by loosening the locking knob at the bottom of the mast (W). Turn the mast until the lights face in the desired direction and then tighten the knob.

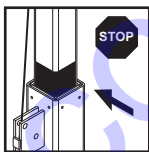

DETAIL V

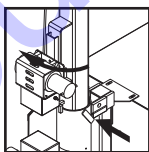

DETAIL W

⚠ WARNING

Never raise or lower the mast while the unit is operating! Never remove the safety pin or mast lock while the tower is up. Releasing the lock will cause the mast to fall.

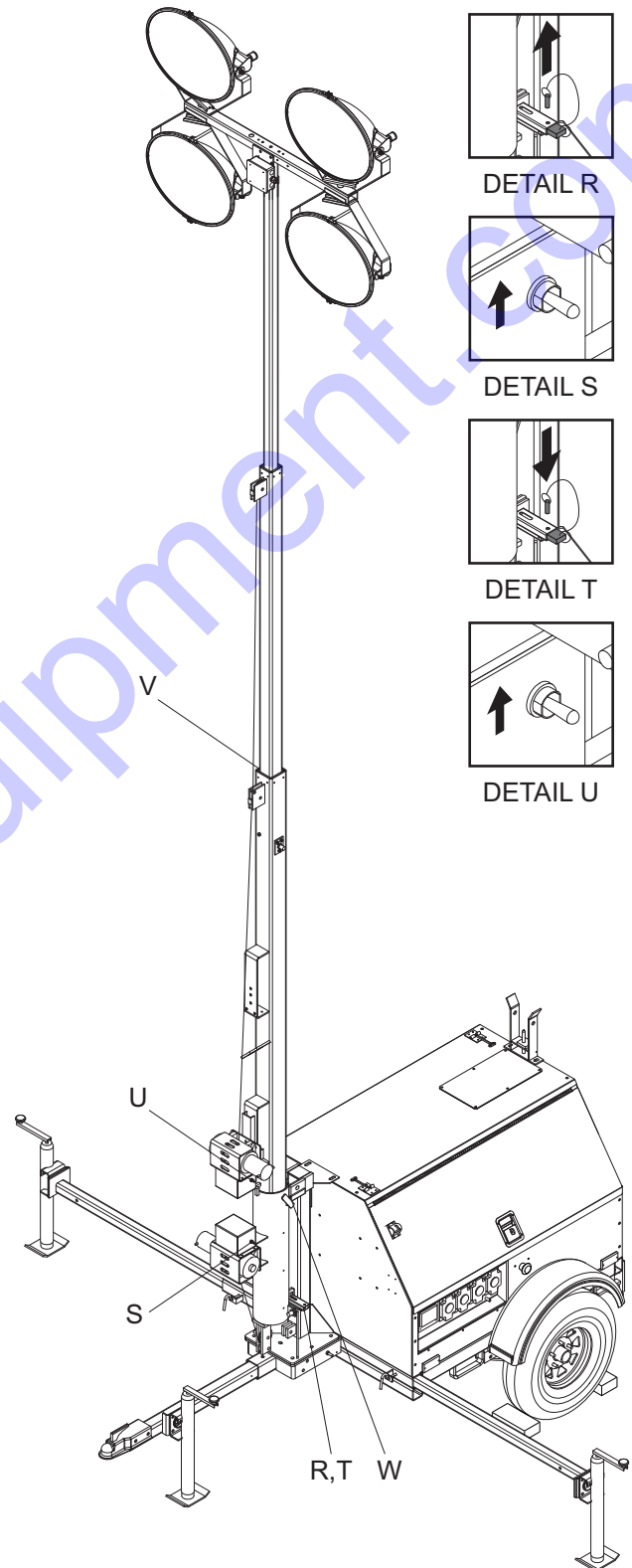

LIGHT TOWER START UP

Before starting the light tower, carefully read the pre-start check list. Make sure that all of the items are checked before trying to start the light tower. This check list applies for both manual and remote starting.

PRE- START CHECK LIST

- Make sure the control ON/OFF toggle switch is in the OFF “O” position.
- Make sure that the circuit breakers (main and convenience) are switched OFF “O”.
- Check that the light tower is properly grounded to a good earthen ground per any local and NEC regulations.
- Check all electrical connections at the connection lugs. Are they wired correctly?
- Are the connection lugs tight?
- Check that the voltage selector switch is set to the desired voltage.
- Is the voltage selector switch locked?
- Is the light tower sitting level?
- Check for any water inside, on, or near the unit. Dry the unit before starting.
- Check oil, coolant and fuel levels and engine battery connections.
- Check engine fan belt tension and condition.
- Check engine fan belt guard.
- Check engine exhaust system for loose or rusted components.
- Check radiator and surrounding shroud for debris.
- Are any of the generator covers loose or missing?
- Are all preventative maintenance procedures up to date?
- Check that the battery disconnect switch is on, if equipped.

MANUAL STARTING OF THE LIGHT TOWER

1. Move the control ON/OFF toggle switch to the “CONTROL ON / I” position.
2. The Liquid Crystal Display (LCD) window will quickly display system information, all Light Emitting Diodes (LED’s) will flash.

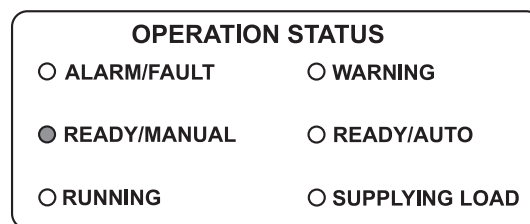
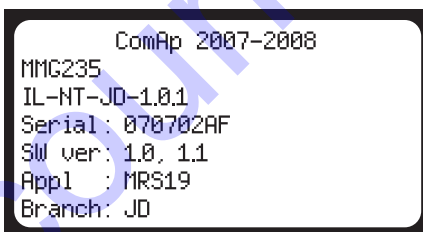

3. The LCD window will indicate MANUAL mode and Ready. The Ready/Manual LED will be lit. **Note:** The unit must be in the “MAN” Mode with the Ready/Manual LED lit to start the unit.

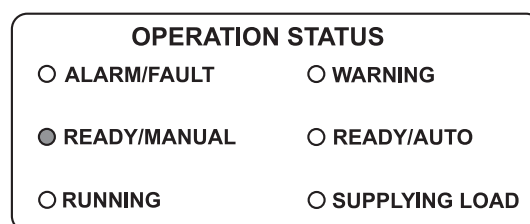
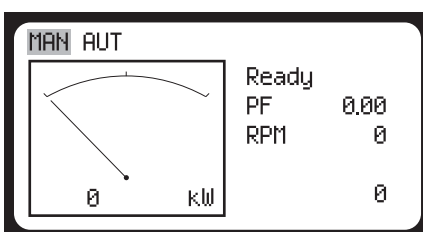

4. Press the green "ENGINE START" button. The Prestart (Preheat) screen will be displayed (if equipped) and a countdown will begin from 20 seconds to 0.

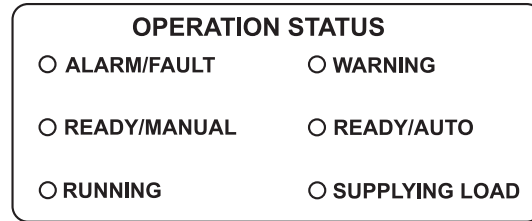
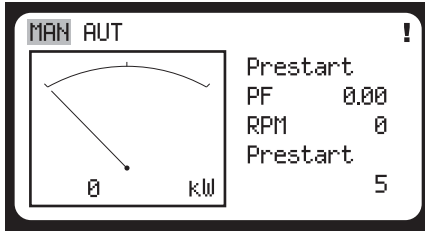

5. The Starting screen will be displayed. The engine will crank and start running.

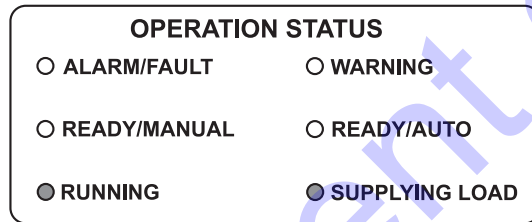
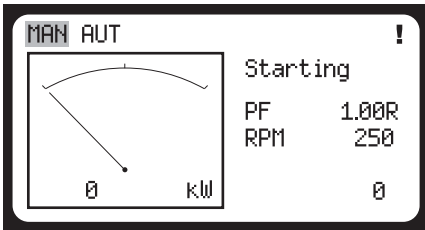

6. The Running screen will display. **Note:** It may take a few seconds for the engine to run smoothly and reach its governed operating speed. The 45 second "SENSING" time delay will start to count down.

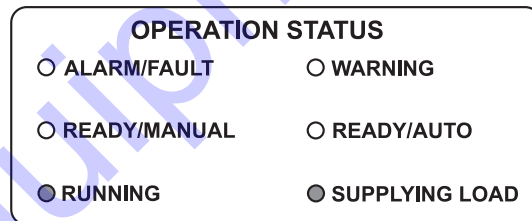
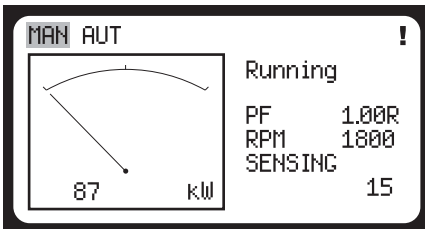

7. The LCD window will then toggle from the Running screen to the Generator Display Screen and then to the Engine Display Screen.

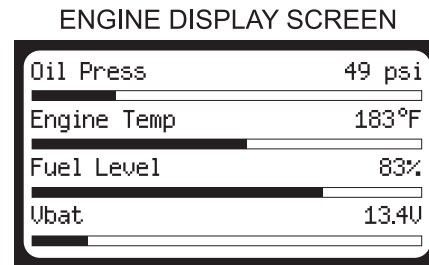
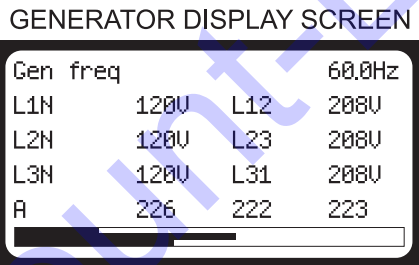

8. If the engine does not start after the first cranking attempt, the engine will pause for 15 seconds to allow the starter to cool. The LCD window will show "PAUSE". The engine will make two more attempts to start for a total of three crank cycles.
9. Should the engine not start and run within 3 starting cycles, the LCD window will show "SD Start fail". The starting sequence may be repeated after the starter has had a minimum of two minutes to cool. Press the "FAULT RESET" button to clear the controller. To start the unit, press the green "ENGINE START" button. **Note:** The engine controller may skip the preheat engine steps on some of the larger models.

10. Once the engine starts it will immediately begin speeding up to a constant 1800 rpm. On units with isochronous engine governing, the engine may hunt or change speeds until operating temperature is reached. After a few minutes of operation, the engine will be warmed up and the LCD window will show engine and generator operating parameters. Temperature will be shown as "0" until the engine temperature is approximately 100° F.
11. Once the generator is at normal operating temperature, check the generator for excessive noise or vibration and any coolant, oil or fuel leaks before applying any loads.
12. Check that the AC output voltage is correct. The output voltage can be fine adjusted by using the fine voltage adjustment screw (rheostat), as described on page 15.
13. Check that the frequency (Hz) is correct. With no loads connected to the generator, the frequency should read approximately 60-62 Hz, depending on the type of engine governing used.
14. If all wiring connections have been made correctly, switch the main circuit breaker to the "ON / I" position and then add any loads attached to the convenience outlets by switching the respective circuit breaker to the "ON / I" position. You will notice a slight change in engine sound when a load is applied to the unit.

"AUTO" (REMOTE) STARTING OF THE LIGHT TOWER

The "AUTO" button is used when the generator is started from a location other than the control panel and by using a dry-contact closure remote start switch (transfer switch). "AUTO" (remote start) is the normal setting when the generator is being used as a standby power supply. Before putting the generator in the "AUTO" mode, review the Pre-Start Check List and Manual Starting of the Generator sections beginning on page 28. Also follow all safety warnings and information on isolating the generator with a transfer switch if the unit is to be used as a standby power supply, as described on pages 23 and 24. Then continue with the steps described below:

1. Perform a manual start of the generator at least once to verify that the engine is operating correctly.
2. If a check of the remote start circuit is desired, remove the wires from the remote start terminal block. Press the "AUTO" button, the Liquid Crystal Display (LCD) window should highlight "AUTO" in the upper left corner. Attach a jumper wire (minimum 16 gauge) across the two terminals on the remote start terminal block. This applies a ground to the Magnum Digital Controller (MDC) to close the starting circuit contacts. The engine should crank, start and run.
3. Remove the jumper wire from the remote start terminal block and the engine will stop. Reconnect any necessary wires from the remote start switch (transfer switch) to the remote start terminal block.
4. Confirm unit is in "AUTO" mode. The LCD window should have "AUT" highlighted in the upper left corner.
5. Close (set to "ON / I") the main circuit breaker.
6. Secure the generator by closing and locking all access doors.
7. The generator is now ready for remote starting.

LIGHT OPERATION

1. Once the engine is up to temperature and running smoothly, switch main circuit breaker to the ON "I" position.
2. With main circuit breaker on, switch each individual circuit breaker for the lights to ON "I", one at a time.
3. The green ballast indicator lights will come on momentarily as the lights strike. As the lights warm up, the ballast indicator lights will continue to get brighter and then remain on. This confirms that power is coming from the ballasts to the lights.
4. If an indicator light does not come on, the ballast may need to be serviced. If the indicator light comes on and stays lit but the related light is not illuminated, check the bulb or the mast wiring. Refer to the troubleshooting section on page 37.
5. The lights require a warm up period of 5-15 minutes before they reach full output. If the lights are shut down, they require a cool-down period of approximately 10 minutes before they can be switched on again.
6. The light tower uses four 1000W bulbs. When checking or replacing the bulbs, wipe them with a clean cloth to avoid leaving any grease, oil residue or fingerprints on the glass. Any residue can create a hot spot on the bulb, causing premature bulb failure.

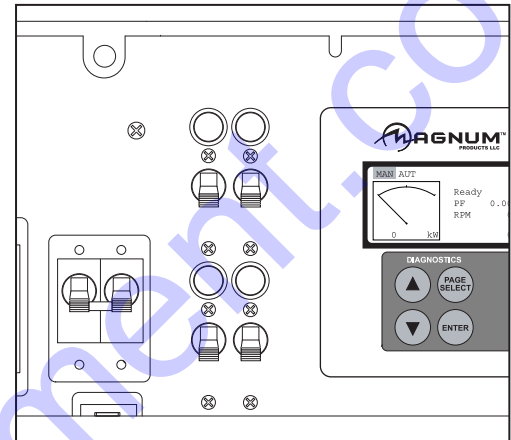

⚠ WARNING

NEVER OPERATE THE LIGHTS WITHOUT THE PROTECTIVE LENS COVER OR WITH A LENS COVER THAT IS CRACKED OR DAMAGED! The bulbs in the light fixtures produce high temperatures and operate under pressure. A broken or missing lens cover could cause the bulbs to shatter, causing injury.

⚠ CAUTION

Bulbs become extremely hot when in use! Allow bulb fixture to cool 10-15 minutes before handling or lowering tower.

SHUTTING DOWN

When you have finished using the light tower, proceed with shut down as follows:

1. Remove any loads from the auxiliary outlets.
2. Switch the individual circuit breakers for each light to the OFF "O" position.
3. Switch the main circuit breaker to the OFF "O" position.
4. Push the red "ENGINE STOP" button. Pressing "Engine Stop" will result in the light tower going into the shutdown cycle and starting a 15 second shutdown timer called "Stop Value". If the unit does not shutdown within 15 seconds a "Stop Fail" alarm will be displayed on the Liquid Crystal Display (LCD) window.
5. Move the "CONTROL ON / I" toggle switch to the "CONTROL OFF / O" position.

LOWERING THE TOWER

1. Shut down the lights and engine. Allow the lights to cool 10-15 minutes before lowering the tower.
2. Turn the upper mast winch handle to collapse the tower to its lowest position. Make sure the electrical cord returns to the storage tube properly.

⚠ WARNING

If the mast hangs up or the winch cable begins to develop slack, STOP IMMEDIATELY! Excess slack in the cable could cause the mast to collapse should it free up without warning. Contact an authorized service center.

3. Loosen the mast rotation knob and rotate the tower so the mast mounted winches face the front of the unit. The white alignment arrow points should line up on the mast sections and the metal stop tabs should be touching. Tighten the mast rotation knob.
4. Release the mast lock by pulling the safety pin on the mast lock and pulling the lock free. Turn the handle of the lower mast winch until the mast spring begins to pivot the tower down. Release the mast lock and continue to lower the tower until it rests in the cradle. **Note:** *If the mast lock does not pull free, operate lower winch slightly to relieve pressure on the mast lock.*
5. After the mast is completely down, insert the cradle lock pin and secure it with the safety pin.
6. If the trailer is going to be moved, Magnum Products LLC strongly recommends that the lights be removed from the mast and stowed for transportation. See REMOVING THE LIGHTS FOR TRANSPORTATION section on page 33.

LOWERING THE TOWER EQUIPPED WITH THE OPTIONAL ELECTRIC WINCH

1. Shut down the lights and engine. Allow the lights to cool 10-15 minutes before lowering the tower.
2. Loosen the mast rotation knob and rotate the tower so the mast mounted winches face the front of the unit. The white alignment arrow points should line up on the mast sections and the metal stop tabs should be touching. Tighten the mast rotation knob.
3. Press and hold the upper winch control toggle switch downward to collapse the mast to its lowest level. Make sure the coiled electrical cord on the top sections of the mast does not get tangled on the mast sections. **Note:** *Some electric winch models are equipped with an anti-backlash safety limit switch. This switch will disconnect power to the winch if excess cable slack is detected, preventing accidental lowering of the tower. If, for any reason, the cable begins to develop slack or any of the tower sections get stuck, STOP IMMEDIATELY and contact an authorized service center.*
4. Release the mast lock bar by pulling the safety pin on the mast lock and pulling the lock bar free. Lower the mast by holding the lower winch control toggle switch to the right until the mast is resting in the transport cradle. **Note:** *If the lock bar does not pull free, activate lower winch slightly to relieve pressure on the mast lock bar.*
5. After the mast is completely down, insert the cradle lock pin and secure it with the safety pin.
6. If the trailer is going to be moved, Magnum Products LLC strongly recommends that the lights be removed from the mast and stowed for transportation. See REMOVING THE LIGHTS FOR TRANSPORTATION section on page 33.

REMOVING THE LIGHTS FOR TRANSPORTATION

1. On units equipped with quick disconnect fittings for the lights, disconnect the power cords from the junction box at the top of the mast. Replace the dust caps on the junction box. On other units, remove the junction box cover on the top of the mast and disconnect **ONLY** the mast light wires from the terminal blocks. To release the wires from the terminal blocks, flip the locking levers down and pull out the appropriate wires (A).
2. Remove the lights by removing the wing nut that holds the light fixture bracket to the cross tube. Attach the lights to the storage brackets (if equipped) located on the mast tube on either side of the central lifting eye.

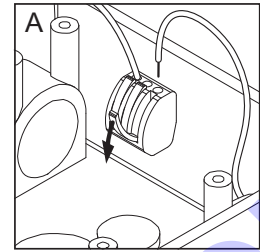

TOWING THE TRAILER

Once the engine is shut down and the mast and lights are properly stowed, the trailer can be made ready for transport.

1. Raise the rear jack completely and release the locking pin to rotate it up into the travel position. Make sure the locking pin snaps into place.
2. Raise the outrigger jacks completely and release the jack locking pin to swing the jacks up into the travel position. Make sure the locking pins snap into place. Release the outrigger locking pins and slide the outriggers into the trailer frame until the locking pins snap into place.
3. Use the tongue jack to raise or lower the trailer onto the hitch of the towing vehicle. Lock the hitch coupling and attach the safety chains or cables to the vehicle. Release the jack locking pin and rotate the jack into the travel position. Make sure the locking pin snaps into place.
4. To ensure proper operation of the jacks, lube the grease fittings located on the leveling jacks.
5. Connect any trailer wiring to the tow vehicle. Check for proper operation of the stop and signal lights.
6. Make sure the mast cradle locking pin is in place.
7. Make sure the doors are properly latched.
8. If the trailer is going to be driven over rough ground, remove the bulbs from the light fixtures.
9. Check for proper inflation of the trailer tires. The maximum tire inflation is 50 psi.
10. Attach a red flag to the end of the mast before towing.
11. Check the wheel lugs. Tighten or replace any that are loose or missing. If a tire has been removed for axle service or replaced, tighten the lugs in the order shown to the following specifications:

- A. Start all lug nuts by hand.
- B. First pass tighten to 20-25 Ft-Lbs (27-33 Nm).
- C. Second pass tighten to 50-60 Ft-Lbs (67-81 Nm).
- D. Third pass tighten to 90-120 Ft-Lbs (122-162 Nm).

After the first road use, re-torque the lug nuts in sequence.

12. Maximum recommended speed for highway towing is 45 mph. Recommended off-road towing speed is not to exceed 10 mph or less depending on terrain.

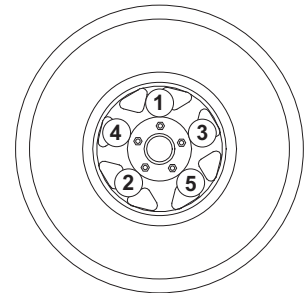

TRAILER WHEEL BEARINGS

The generator is equipped with a grease zerk fitting to allow lubrication of the wheel bearings without the need to disassemble the axle hub. To lubricate the axle bearings, remove the small rubber plug on the grease cap, attach a standard grease gun fitting to the grease zerk fitting and pump grease into the fitting until new grease is visible around the nozzle of the grease gun. Use only a high quality grease made specifically for lubrication of wheel bearings. Wipe any excess grease from the hub with a clean cloth and replace the rubber plug when finished. The minimum recommended lubrication is every 12 months or 12,000 miles; more frequent lubrication may be required under extremely dusty or damp operating conditions.

LIFTING THE TRAILER

When lifting the light tower and trailer, attach any slings, chains or hooks directly to the central lifting eye. The lifting eye is located on the mast between the two forklift pockets.

1. Make sure the equipment being used to lift the light tower has sufficient capacity. **Note:** See the unit specifications on pages 8 - 9 for approximate weights.
2. Make sure the mast cradle locking pin is in place.
3. Always remain aware of the position of other people and objects around you as you move the unit.

GENERAL MAINTENANCE

Poorly maintained equipment can become a safety hazard! In order for the equipment to operate safely and properly over a long period of time, periodic maintenance and occasional repairs are necessary. **NEVER** perform even routine service (oil/filter changes, cleaning, etc.) unless all electrical components are shut down. When servicing this equipment always follow the instructions listed below.

Before servicing this machine, make sure the control power switch is turned to OFF "O", the circuit breakers are open (OFF "O"), the emergency stop switch is activated (pushed in), and the negative (-) terminal on battery is disconnected. Attach a "DO NOT START" sign to the control panel. This will notify everyone that the unit is being serviced and will reduce the chance of someone inadvertently trying to start the unit. If the unit is connected to a remote start or transfer switch, make sure the remote switch is also off and tagged.

Never wash the unit with a high pressure hose or with any kind of power washer. Never wash the engine block or fuel tank with a power washer or steam cleaner. Water may enter the cabinet and collect in the generator windings or other electrical parts, causing damage. If the unit is stored outside, check for water inside the cabinet and generator and dry the unit thoroughly before starting.

1. Inspect condition of electrical cords. **DO NOT** use light tower if insulation is cut or worn through.
2. Check that winch cables are in good condition and that they are centered on each pulley. **DO NOT** use a cable that is kinked or starting to unravel.

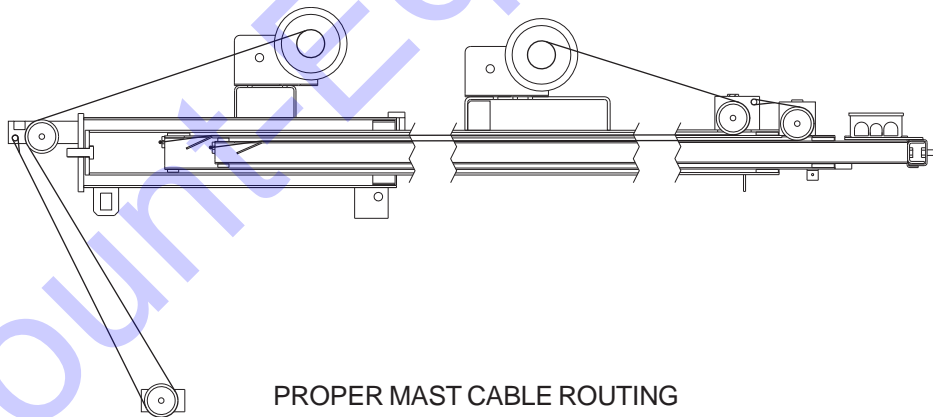

3. Check that the safety pins for the mast lock rod and mast lock bar are present and secured with a chain. Check that the spring located in the mast lock bar is not broken or missing. Check the operation of the mast lock bar.
4. Check the fuel, oil and coolant levels.
5. Check the operation of the trailer parking brake (if equipped).
6. Check the wheel lugs. Tighten or replace any that are loose or missing. If a tire has been removed for axle service or replaced, tighten the lugs in the order shown on page 33.

ENGINE MAINTENANCE

Note: During the first 50 hours of operation, avoid long periods of no load or sustained maximum load operation. If the light tower is to run for longer than five minutes without a load, shut the engine down.

The engine is supplied with engine break-in oil from the factory. Extra care during the first 50 hours of engine operation will result in better performance and longer engine life. DO NOT exceed 50 hours of operation with the break-in oil. Operate the engine at lighter loads (50-75% of maximum) as much as possible. If the engine has spent significant time at idle, constant speeds and/or light load or if makeup oil is required, a longer break in period may be needed. Consult the engine OPERATION AND MAINTENANCE MANUAL for a full description of necessary procedures on the addition of break-in oil and extension of the break-in period.

The periodic maintenance schedule below lists basic maintenance intervals for the engine. For detailed maintenance procedures refer to the engine operators manual. A copy of this manual was supplied with the unit when it was shipped from the factory. For additional or replacement copies of the engine operators manual, contact an authorized engine dealer in your area.

	Check Daily	Every 50 Hours	Every 250 Hours	Every 500 Hours	Every 1000 Hours	Every 2 Years
Check Tire Pressures	■					
Check Engine Oil Level	■					
Check Engine Coolant Level	■					
Check Fuel Level	■					
Check Alternator Belt	■					
Drain Fuel Filter*		■				
Check Radiator Hoses		■				
Change Engine Oil & Filter**		■	■			
Check All Electrical Connections			■			
Check For Fuel Leaks			■			
Replace Fuel Filter Element***			■			
Inspect and Clean Radiator Fins				■		
Lubricate Leveling Jacks				■		
Clean Air Filter Element, replace if necessary				■		
Replace Alternator Belt				■		
Inspect Engine Starting Battery					■	
Check Valve Clearance						■
Drain and Clean Fuel Tank						■
Change Engine Coolant						■
Replace Radiator Hoses						■

* Drain daily in humid or rainy conditions.

** Change the engine oil and filter after the first 50 hours of operation, then every 250 hours.

OPTIONAL LOWER RADIATOR HOSE HEATER USE AND MAINTENANCE

The following points should be followed when operating a unit equipped with a lower radiator hose heater.

▲ WARNING

Improper use of the lower radiator hose heater could result in serious personal injury.

- Ensure cooling system is full of proper mixture of water and engine coolant before each heater use.
- Heater is designed for all-night operation; however, 2-5 hours of heating just prior to starting is usually sufficient for proper engine starting.
- When heater is in operation, unit must be parked in a level position to maintain the proper orientation of the heater.
- Use only an undamaged extension cord, outdoors rated, three-prong grounded 120VAC cord with a minimum amperage rating of 10A. Connect to properly grounded 120VAC, GFCI outlet only.
- Unplug extension cord from power first; then unplug heater cordset from extension cord before starting the engine.

DERATING FOR ALTITUDE

All light towers are subject to derating for altitude and temperature; this will reduce the available power for operating tools and accessories connected to the auxiliary outlets. Typical reductions in performance are 2-4% for every 1000 ft. (305 meters) of elevation and 1% per 10° F (3-5° C) increase in ambient air temperature over 72° F (22.2° C).

TROUBLESHOOTING SHUTDOWN CONDITIONS

LOW OIL PRESSURE SHUTDOWN

1. Check the level of the engine oil with the dipstick. The engine controller will shut the engine down when the oil pressure is less than 20 psi. Add oil if required.
2. Visually inspect the engine for oil leaks.
3. If the oil level is good, restart the unit and verify the loss of oil pressure. Shut the engine down immediately if the oil pressure value does not read 5 psi within five (5) seconds.
4. Check the oil pressure sender on the engine block and the connecting wiring for damage. To check for continuity between the sender and the engine controller, remove the bolts at the top and center of the control panel and open the panel like a door. Consult the DC wiring diagrams in this manual for the proper path between the engine controller and the pressure sender.
5. If the oil level, pressure sender and wiring are good, the oil loss may be caused by engine failure. Consult the ENGINE OPERATION AND MAINTENANCE MANUAL for additional information on excessive oil consumption.

HIGH COOLANT TEMPERATURE SHUTDOWN

1. Check the coolant level in the overflow jug.
2. Restart the engine and read the coolant temperature to verify High Coolant Temperature Shutdown. Stop the engine immediately if the coolant temperature is 230°F or more.
3. **Allow the engine to cool!** Add coolant to the overflow jug if it is low and then check the level of coolant in the radiator. To access the radiator cap, you must remove the small access panel located on top of the generator enclosure directly above the radiator. Add coolant until it is 3/4" below the filler neck. Replace the radiator cap and access panel.
4. Check the radiator shroud and ducting for blockage and remove any foreign matter.
5. Inspect coolant hoses, engine block and water pump for visible leaks.
6. Check the tension of the serpentine drive belt for the water pump.
7. Check the coolant temperature sender on the engine block and the connecting wiring for damage. To check for continuity between the sender and the engine controller, remove the bolts around the control panel and slowly drop panel down. Consult the DC wiring diagrams in this manual for the proper path between the engine controller and the pressure sender.
8. If the sender and wiring are good and no other problems are found, restart the engine. Observe the coolant temperature and shut the engine down immediately if it starts to overheat.
9. Reduce the load on the generator and restart the engine. Observe the coolant temperature and shut the engine down immediately if it starts to overheat. Consult the ENGINE OPERATION AND MAINTENANCE MANUAL for additional information on engine overheating.

OVERCRANK SHUTDOWN

1. Check the fuel level in tank.
2. Check for proper operation of the fuel pump.
3. Check air filter for blockage.
4. If the engine will not start, consult the ENGINE OPERATION AND MAINTENANCE MANUAL for additional information on troubleshooting starting problems.

OVERSPEED OR UNDERSPEED SHUTDOWN

1. Disconnect all loads and restart the generator. Read the frequency (Hz) on the LCD display. With no loads on the generator, the frequency should read 60.0 Hz.
2. If the frequency is above or below 60.0 Hz, the engine speed will have to be adjusted. See the ENGINE OPERATION AND MAINTENANCE MANUAL for throttle adjustments on mechanically governed units and see the ELECTRONIC GOVERNOR MANUAL for electronically controlled units.

TROUBLESHOOTING THE LIGHTS

⚠ DANGER

HIGH VOLTAGE! THIS UNIT USES HIGH VOLTAGE CIRCUITS CAPABLE OF CAUSING SERIOUS INJURY OR DEATH. ONLY A QUALIFIED ELECTRICIAN SHOULD TROUBLESHOOT OR REPAIR ELECTRICAL PROBLEMS OCCURRING IN THIS EQUIPMENT.

MAST LIGHTS OFF BUT BALLAST INDICATORS ON CONTROL PANEL ARE ON:

1. Mast light is too hot. Allow light to cool 10-15 minutes before restarting.
2. Faulty bulb connection. Check that the bulb is tight in the socket.
3. Bulb broken. Check for broken arc tube or outer bulb jacket, broken or loose components in bulb envelope or blackening/deposits inside tube.
4. Check the connections inside the mast junction box and each mast light housing/socket.
5. Check the mast electrical cord for damage and check the cord connections inside the control box.

MAST LIGHTS OFF AND BALLAST INDICATORS ON CONTROL PANEL ARE OFF:

1. Check the connections inside the control box and inside each ballast box.
2. Generator output incorrect. Check the incoming voltage to the ballast by checking the available voltage on the duplex receptacle. Incoming voltage should be 120V +/- 5V. If voltage is incorrect engine speed may need to be adjusted or generator may require service. Contact Magnum Products Technical Service Department for more information.
3. Low transformer output. The voltage from the transformer should read approximately 400 VAC as the light "strikes" (induces an arc), then drop and slowly rise back up to stabilize at 240-260 VAC. On quick disconnect models, measure across the junction box terminals when the light is unplugged. On hard wired models, remove the mast junction box cover and insert the wire probes into the connector blocks for the lights and ground. If proper voltage is not achieved, perform capacitor check to determine if the capacitor or coil needs to be replaced.

MAST LIGHTS ON BUT THE LIGHT OUTPUT IS LOW:

1. Fixture or lens dirty. Clean reflective surface inside fixture and both inside and outside surface of glass lens.
2. Bulb worn. Replace bulb due to normal use.
3. Check the mast coil cord, mast junction box and mast light connections.
4. Generator output incorrect. Check the incoming voltage to the ballast. Incoming voltage should be 120V +/- 5V. If voltage is incorrect engine speed may need to be adjusted or generator may require service.
5. Low transformer output. Perform transformer check as described above.

If problems persist, contact Magnum Products Technical Service for assistance.

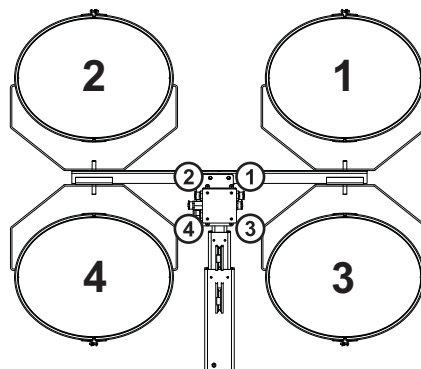

MAST LIGHT CONNECTIONS

UNIT DECALS

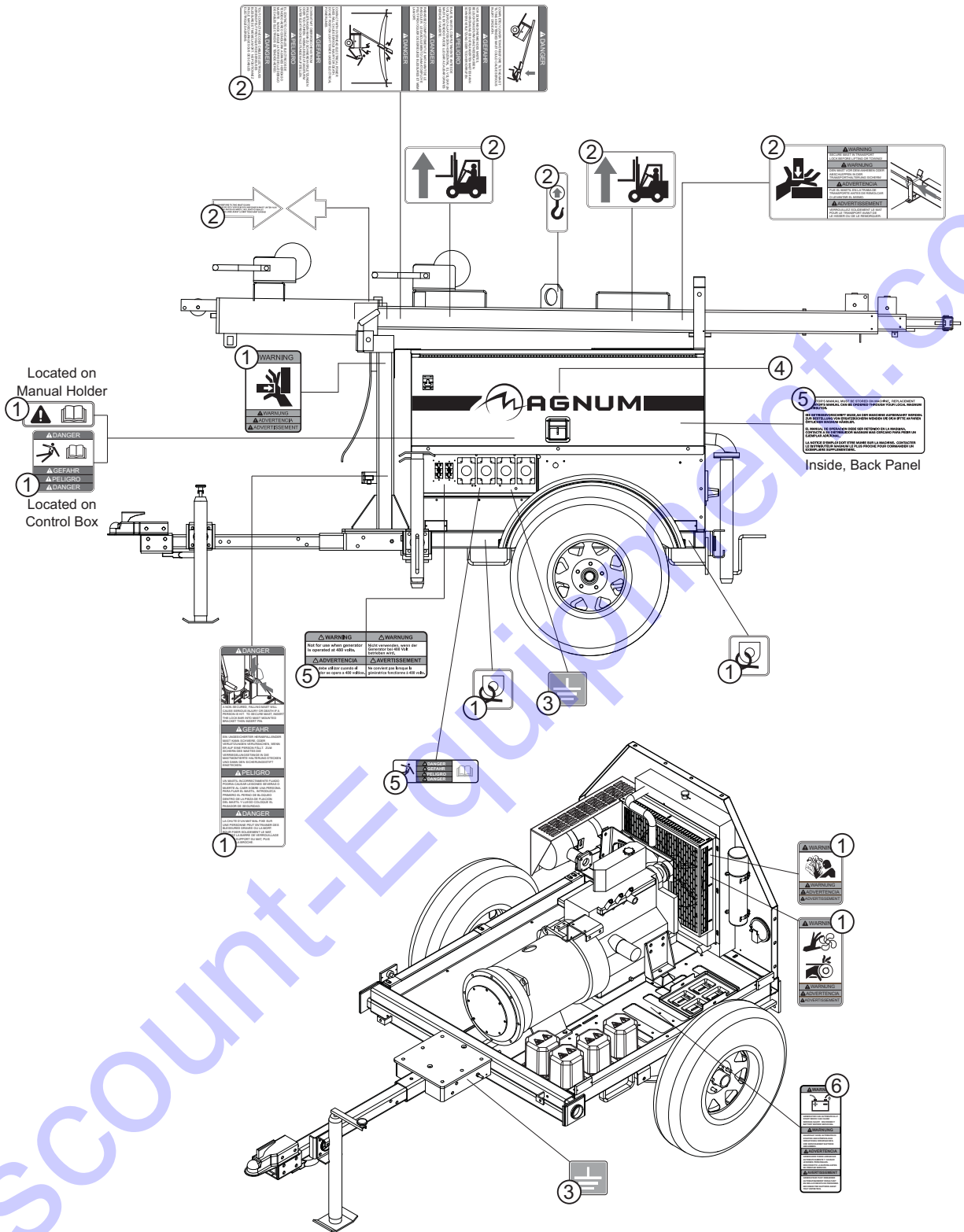

ITEM NO.	PART NO.	QTY	DESCRIPTION
1	12141	1	Decal set, LT eng/safety 4-lang
2	12140	1	Decal set, common mast 4-lang
3	12142	2	Decal, ground
4	16488	1	Decal, Magnum logo with red stripe
5	12191	1	Decal, label set - MLG25

UNIT DECALS

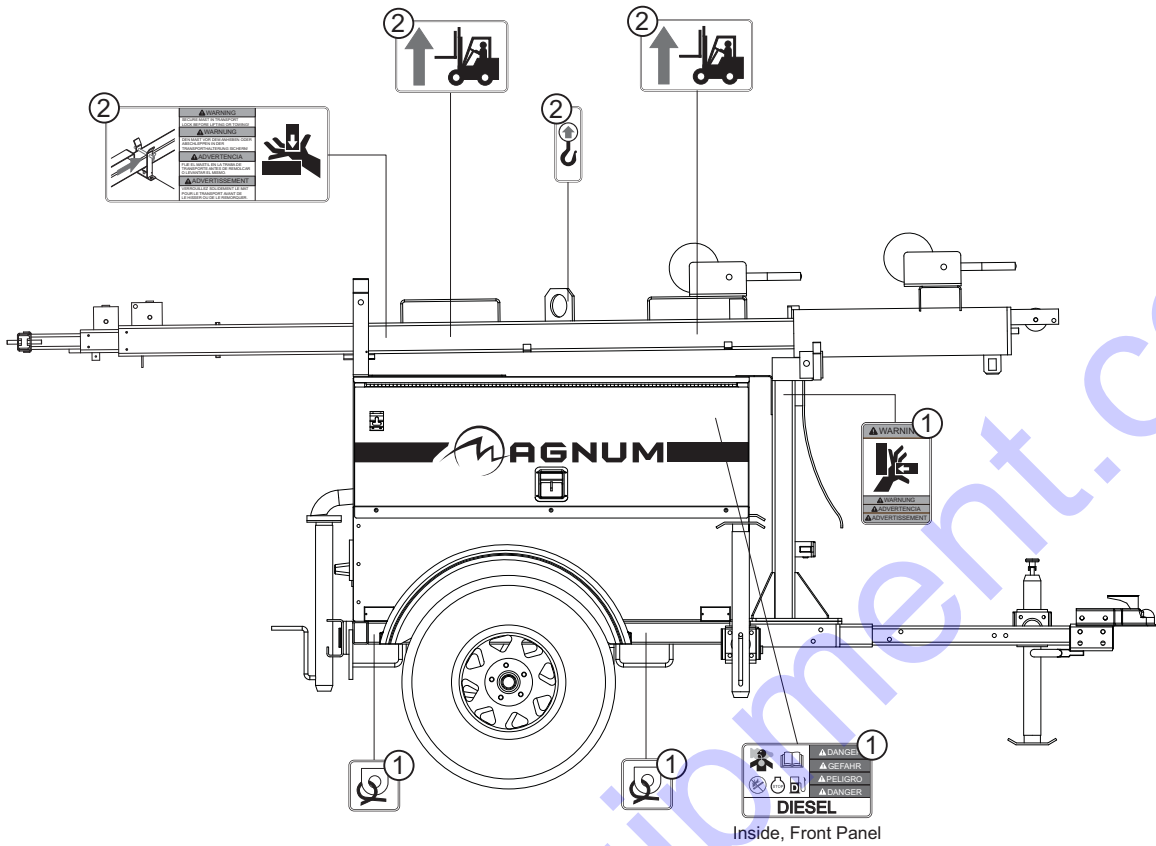

Inside, Front Panel

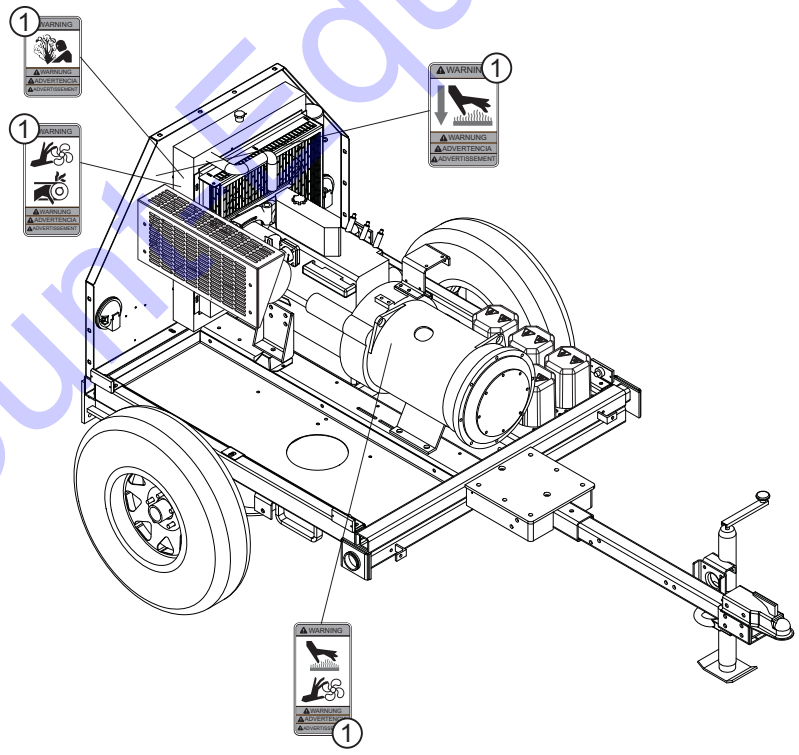

ITEM NO.	PART NO.	QTY	DESCRIPTION
1	12141	1	Decal set, LT eng/safety 4-lang
2	12140	1	Decal set, common mast 4-lang

UNIT DECALS

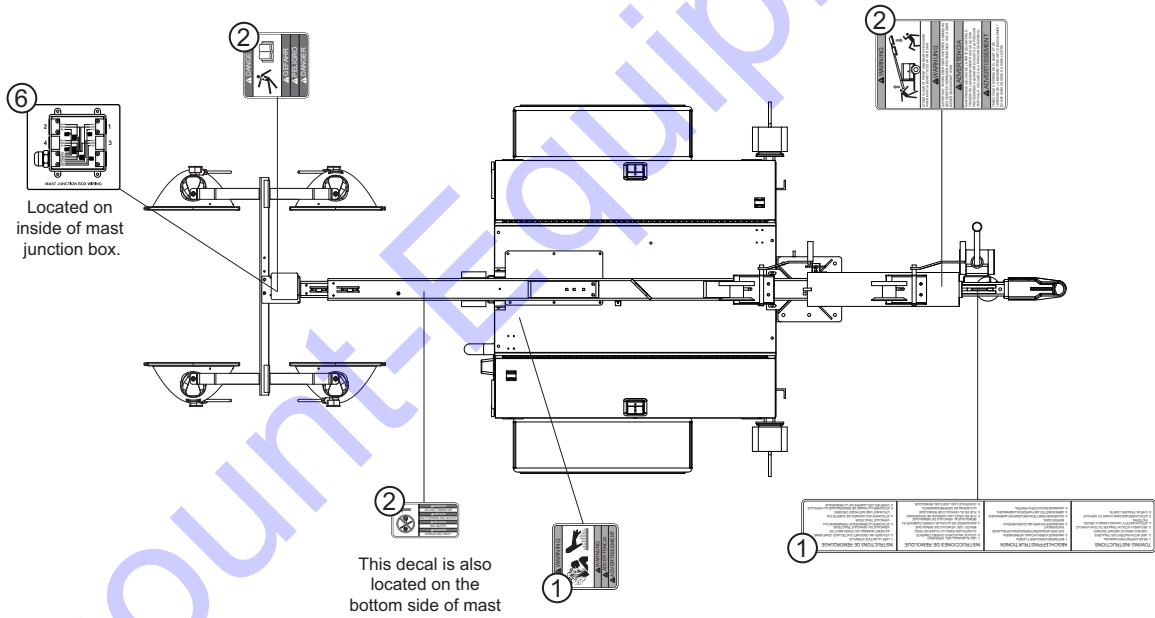
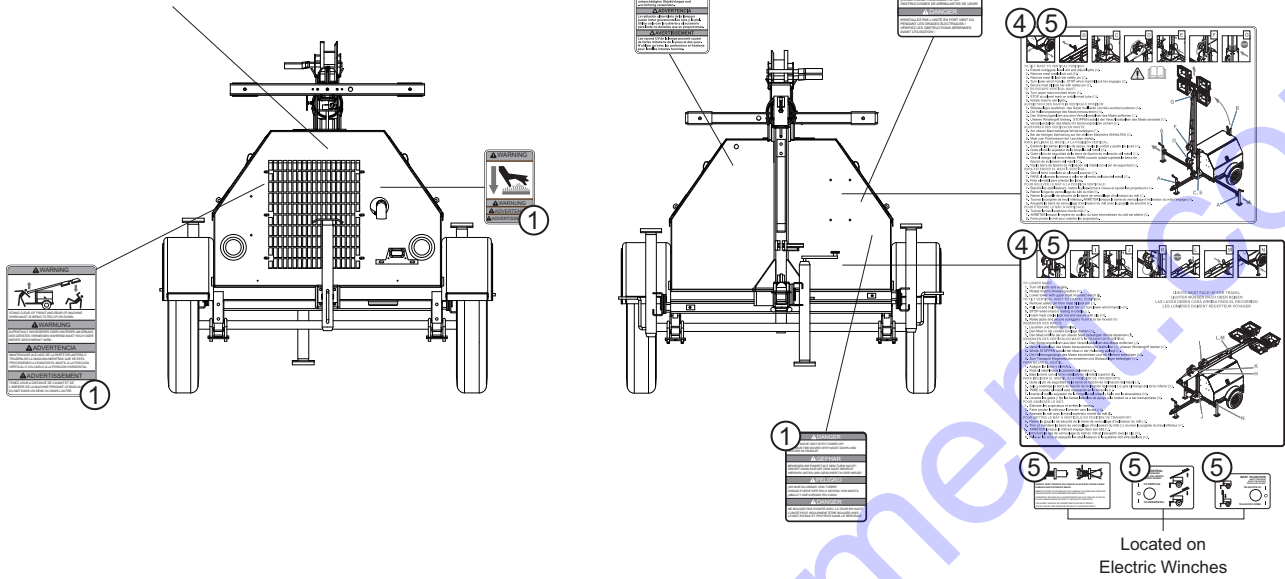

ITEM NO.

PART NO.

QTY

DESCRIPTION

1	12141	1	Decal set, LT eng/safety 4-lang
2	12140	1	Decal set, common mast 4-lang
3	11275	1	Decal, Magnum logo w/web, red vinyl
4	12262	1	Decal, 4000/5000 set up 4-lang (manual winch)
5	12880	1	Decal, instruction 4000/5000 4-lang (electric winch)
6	13614	1	Decal, mast junction box wiring - 4 light

UNIT DECALS

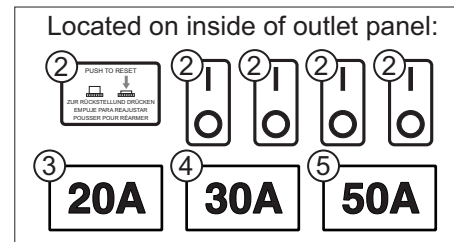
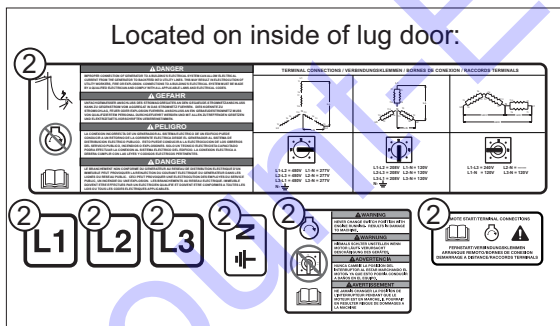
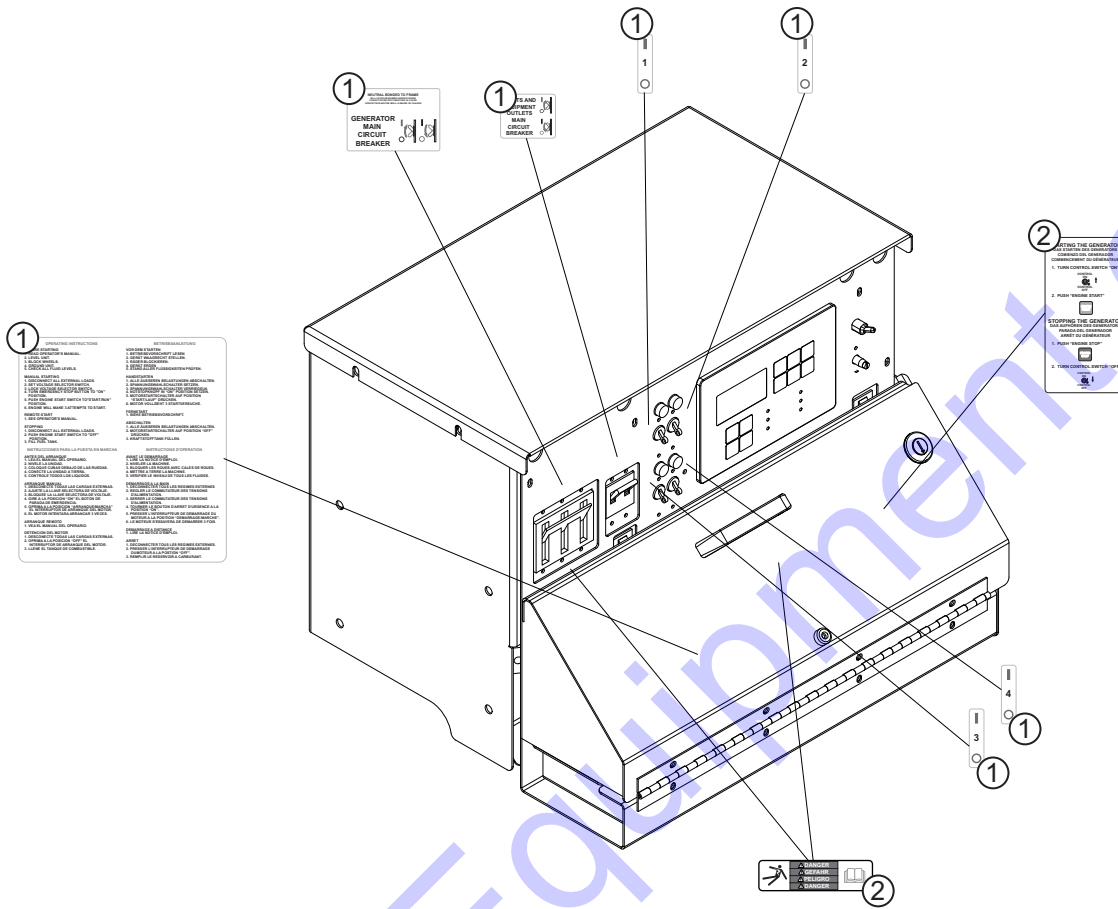

ITEM NO.

PART NO.

QTY

DESCRIPTION

ITEM NO.	PART NO.	QTY	DESCRIPTION
1	13136	1	Decal set, MLT4250
2	12191	1	Decal, label set - MLG25
3	22960	--	Decal, breaker 20 Amp
4	23203	--	Decal, breaker 30 Amp
5	23204	--	Decal, breaker 50 Amp

MANUAL WINCH MAST ASSEMBLY

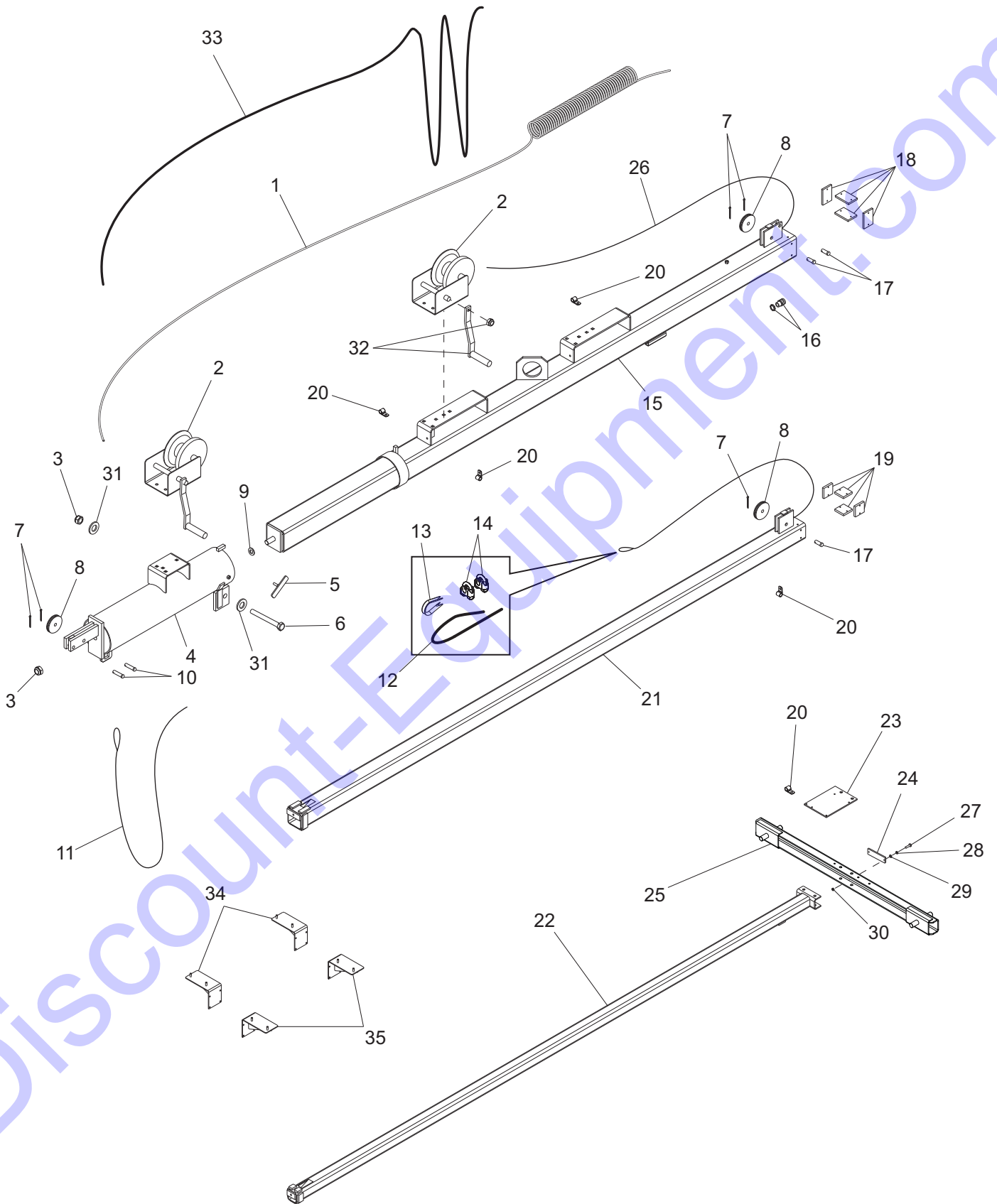

ITEM NO.	PART NO.	QTY	DESCRIPTION
1	11954	1	Coil cord, mast
2	16600	2	Winch, manual
3	60584	2	Nut, .750-10 nylock G5 yellow zinc
4	11902B	1	Weldment, mast tube
5	11649Z	1	Weldment, t-bolt
6	15292	1	Screw, .750-10X6.500 hx hd SS
7	15380	4	Pin, cotter - .125X1.250
8	14262	2	Sheave, 3 in.
9	60247	1	Washer, flat .750
10	14234	2	Pin, clevis .500 x 2.00
11	14798	1	Cable, .188 in. X 16 ft. steel w/teardrop
12	14151	1	Cable, .188 in. X 11 ft. steel w/ball swedge
13	15003	1	Thimble, cable - .188
14	15002	2	Clip, wire rope .188
15	11933B	1	Weldment, mast - 4.00
16	14439	1	Strain relief - .50 NPT, .50 cord, water tight
17	15015	3	Pin, clevis .500 x 1.25
18	15014	4	Shim, 2 x 3 x .281 GSM
19	15013	4	Shim, 2 x 2 x .344 GSM
20	16143	5	Clamp, tubing .500
21	11934B	1	Weldment, mast - 3.00
22	16257B	1	Weldment, mast - 2.00
23	12095B	1	Bracket, junction box
24	15829	1	Reflector, red
25	13527B	1	Weldment, mast crossbar (3/4" studs)
26	15006	1	Cable - .188 in. X 27 ft. galv steel w/swedge
27	60397	1	Screw, 10-32X1.000 pan hd phil
28	60252	2	Washer, split lock #10
29	60237	2	Washer, flat #10
30	14231	2	Nut, 10-32 hx
31	60744	2	Washer, flat .750ID/1.25OD/.06th delrin
32	15623	2	Winch handle, 9.00 in long
OPTIONAL FEATURES:			
33	15612	1	Cable, 16-7 cold mast drape
34	13869B	2	Weldment, light storage (RH oval light)
35	13870B	2	Weldment, light storage (LH oval light)

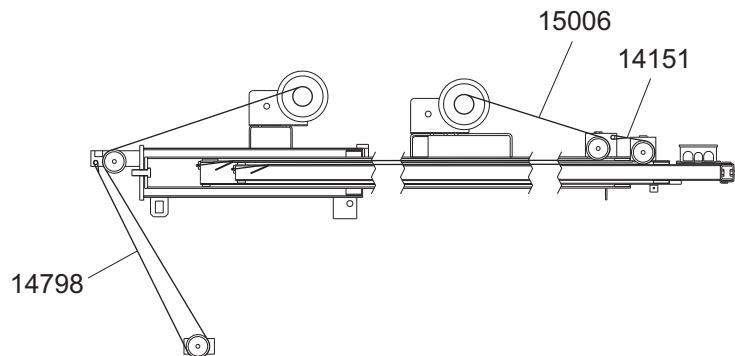

ELECTRIC WINCH MAST ASSEMBLY

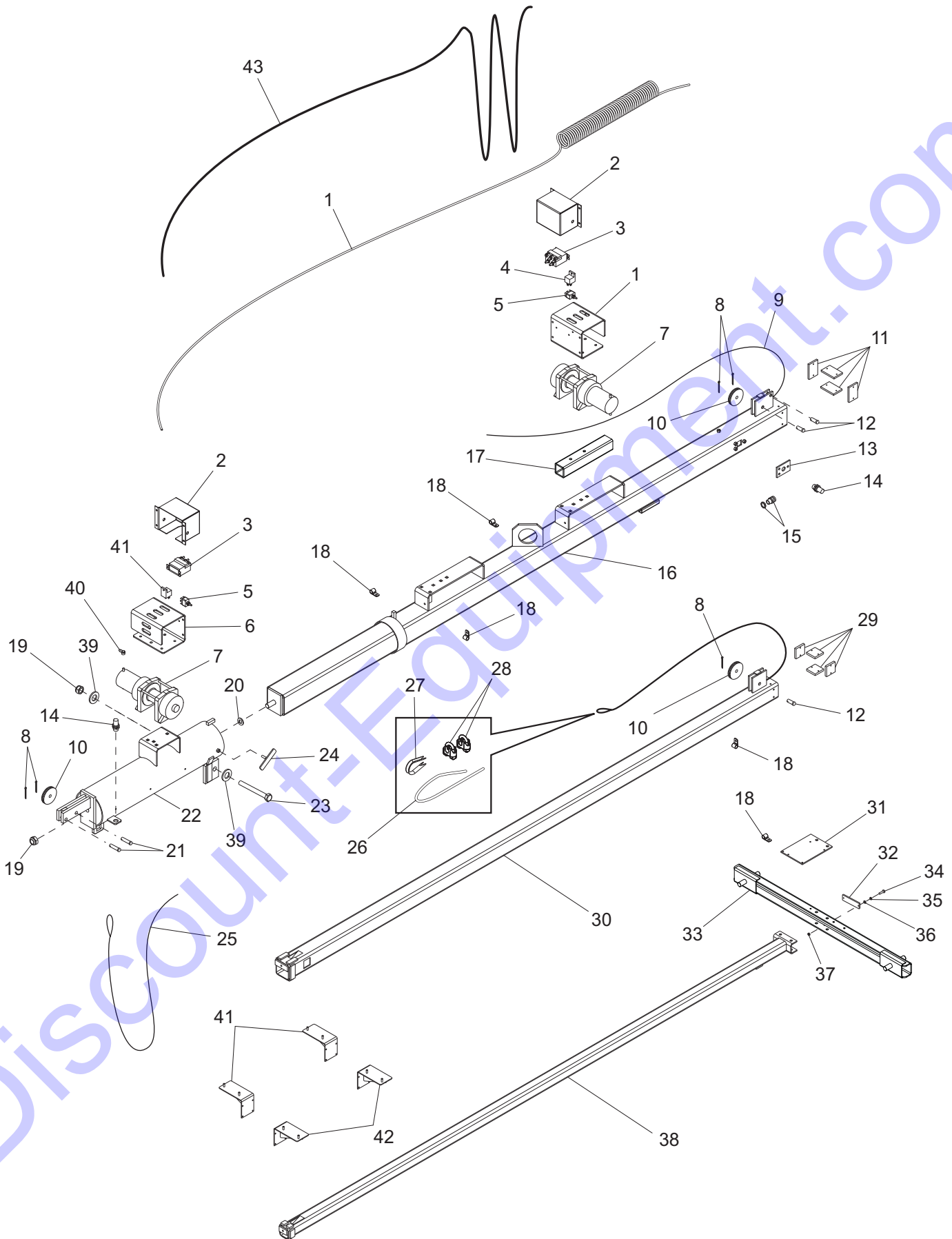

ITEM NO.	PART NO.	QTY	DESCRIPTION
1	11954	1	Coil cord
2	12875B	2	Cover, winch contactor
3	11293	2	Contactora, electric winch - warn
4	65049	2	Relay, 12V 30/40A N.O. w/diode
5	65707	2	Switch, toggle - SPDT spring weatherproof
6	12872B	2	Bracket, winch mounting
7	12874	2	Winch, electric - 770 lb. hoist
8	15380	5	Pin, cotter - .125X1.250
9	15006	1	Cable, .188 in. x 27 ft. w/ball swedge
10	14262	3	Sheave, 3 in.
11	15014	4	Shim, 2 x 3 x .281 GSM
12	15015	3	Pin, clevis .500 x 1.25
13	65510B	1	Bracket, sensor mtg
14	65511	2	Sensor, proximity
15	14439	1	Strain relief- .50 NPT, .50 cord
16	12085B	1	Weldment, 4.00 mast - Electric Winch
17	11967B	1	Channel, electric winch mount
18	16143	2	Clamp, tubing .500
19	60584	2	Nut, .750-10 nylock G5 yellow zinc
20	60247	1	Washer, flat .750
21	14234	2	Pin, clevis .500 x 2.00
22	12876B	1	Weldment, mast tube - Electric Winch
23	15292	1	Screw, 750-10 x 6.50 hx hd SS
24	11649Z	1	Weldment, t-bolt
25	14798	1	Cable - .188 in. X 16 ft. steel w/teardrop
26	14151	1	Cable - .188 in. X 11 ft. steel w/swedge
27	15003	1	Thimble, cable - .188
28	15002	2	Clip, wire rope - .188 single saddle
29	15013	4	Shim, 2 x 2 x .344 GSM
30	12084B	1	Weldment, 3.00 mast
31	12095	1	Bracket, junction box
32	15829	1	Reflector, red
33	13527B	1	Weldment, mast crossbar (3/4" studs)
34	60397	1	Screw, 10-32X1.000 pan hd phil
35	60252	2	Washer, split lock #10
36	60237	2	Washer, flat #10
37	14231	2	Nut, 10-32 hx
38	16257B	1	Weldment, mast - 2"
39	60744	2	Washer, flat .750ID/1.25OD/.06th delrin
40	12922	4	Boot, battery cable - red
OPTIONAL FEATURES:			
41	13869B	2	Weldment, light storage
42	13870B	2	Weldment, light storage
43	15612	1	Cable, 16-7 cold mast drape

FRAME AND COMPONENTS

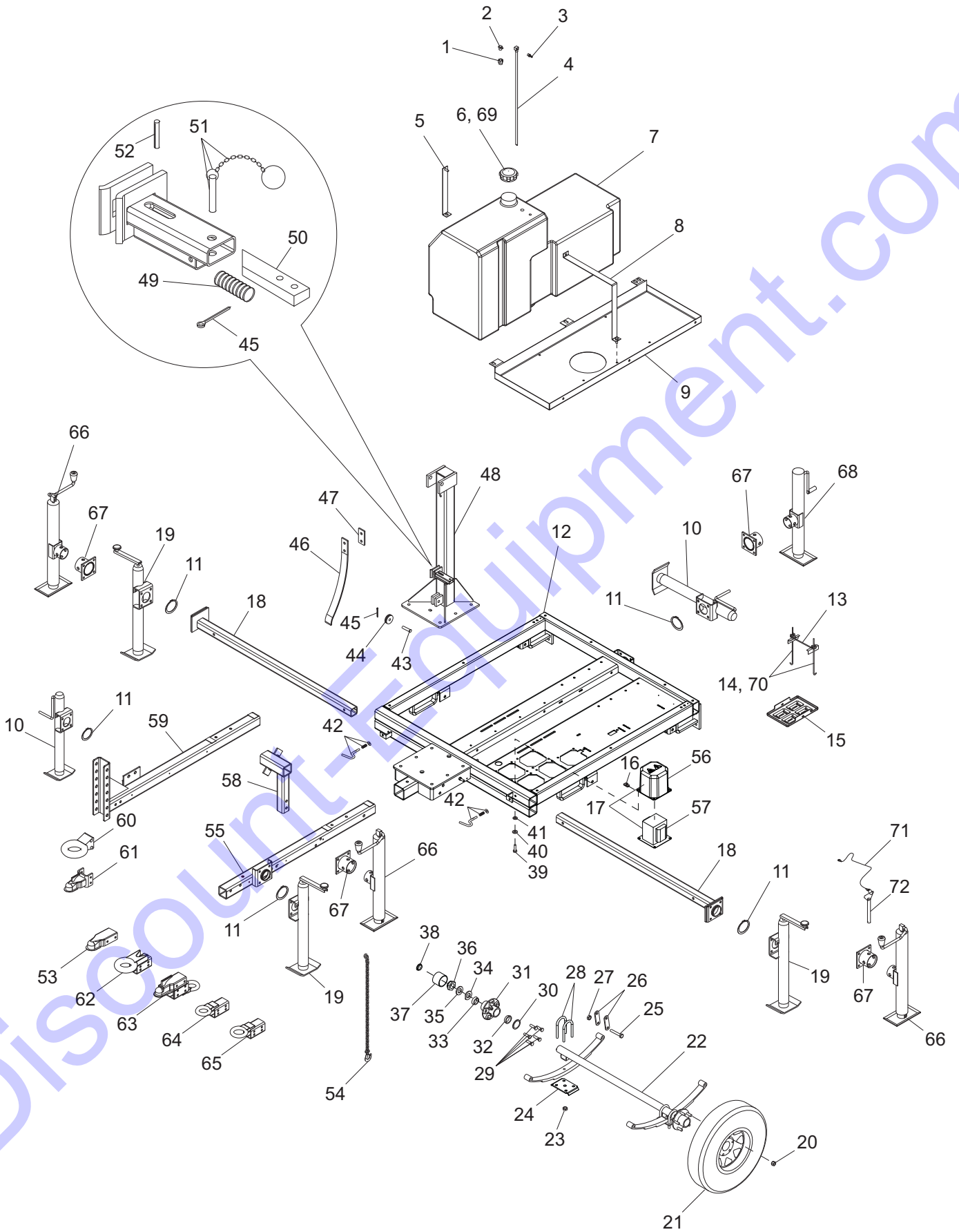

ITEM NO.	PART NO.	QTY	DESCRIPTION
1	16270	1	Fitting, .375MNPT to .250 FNPT straight
2	16271	1	Fitting, 90-.250NPTX.188 barb
3	15142	1	Fitting, strt-.250NPTX.312 barb
4	12259	1	Fuel pick up tube - 24.00 in.
5	12361B	1	Weldment, fuel tank strap
6	12080	1	Cap, fuel tank - vented, 3.5 dia. grn diesel only
7	12162	1	Tank, fuel - 56 gallon poly
8	11735B	1	Weldment, fuel tank strap
9	12120B	1	Panel, fuel tank support
10	11681	1	Jack, sidewind - 2000lb
11	14326	4	Ring, retaining
12	13335B	1	Weldment, chassis
13	14682	1	Bracket, battery hold-down
14	60820	2	Bolt, J - .250-20 X 9.00
15	14145	1	Battery tray
16	61143	16	Nut, .250-20 U-clip G5 PO short type
17	13301	4	Assy, transformer - can and base
18	12408Z	2	Weldment, outrigger
19	11682	3	Jack, top wind - 2000lb
20	60096	10	Nut, .500-20 wheel lug
21	15540	2	Wheel, ST205/75R15, 1820# - 6 PR
22	13131	1	Axle, 3000 lb 58TC 45SC
23	11279	8	Axle nut (Ubolt)
24	11278	2	Tie plate
25	60503	6	Screw, .562-18 hx shackle GR5
26	19637	4	Plate, shackle bracket
27	60504	6	Nut, .562-18 hx shackle lock
28	11277	4	U-bolt
29	60674	10	Stud, wheel
30	70056	2	Bearing seal
31	11276	2	Hub w/races
32	11511	2	Roller bearing
33	70055	2	Bearing L44643
34	12309	2	D-washer
35	12310	2	Tang washer
36	12308	2	Spindle nut
37	70053	2	Dust cap
38	70054	2	Rubber plug
39	60393	16	Screw, .250-20X1.000 hx hd G5
40	60696	16	Washer, .250 flat .625/.050 SS USS
41	60704	16	Washer, .250 split lock SS
42	14324	2	Kit, plunger
43	15015	1	Pin, clevis - .500 DIA X 1.250
44	14261	1	Sheave - 2 in.
45	15380	2	Pin, cotter - .125X1.250
46	14845B	1	Spring, kickback - 50 lb.
47	11554Z	1	Spacer plate - kick-back spring
48	11057B	1	Weldment, mast post
49	14275	1	Spring - 2.75
50	14663Z	1	Bar, latch
51	14403	1	Pin, cotterless - .312 X 1.000
	60707	1	Chain, sash - no 8 stainless steel
	60706	1	Ring, split - 1.00 SS
52	15165	1	Pin, roll - .250X1.250 plain

Continued on next page.

ITEM NO.	PART NO.	QTY	DESCRIPTION
53	16830	1	Coupler - 2.00 ball/2.50 channel
54	23367	1	Chain, safety - 7,800 lbs. rated
55	12420B	1	Weldment, removable tongue
56	13300	4	Cam, transformer - ballast box (5.5" height)
57	13299	4	Transf. & base brkt w/str relief-60Hz MH cyl bal

OPTIONAL FEATURES:

58	12235B	1	Weldment, spare tire holder
59	11368B	1	Weldment, tongue - adjustable hitch w/storage
60	19335B	1	Hitch, pintle eye (adj) - 3.00 ID
61	19518	1	Coupler, adjustable - 2 in. ball
61	11672B	1	Weldment, hitch - 3.00X1.625 ring/2.50 tube
62	16741B	1	Weldment, combo hitch-2.50 tongue removable
64	16835B	1	Weldment, lunette ring - 3.00 ID/2.5 tongue
65	16999B	1	Weldment, lunette ring - 2.50 ID/2.50 tongue
66	23254	3	Jack, 3000# top wind - tube mounted
67	11965Z	4	Weldment, jack adapter
68	11978	1	Jack, 2000# side wind - tube mounted
69	12137	1	Cap, fuel tank - vent 3.5 dia grn
70	60984	2	Bolt, J- .250-20 X 7.00 (for gel cell battery option)
71	23505	4	Cable, pin tether 12"
72	23256	4	Pin, jack - 2000# tube mtd

OPTIONAL FEATURES

For Containment/Silent Pack:

73	10496B	1	Weldment, chassis - 60 gal containment
74	11952	1	Valve, drain - 20X1.5MM thread/barb
75	60777	1	Clamp, hose - .312 fuel hose crimp style
76	50051	1 ft.	Hose, fuel - .375 ID 50 PSI SAE 30R7
77	61157	1	Fitting, 90 - .375 barb X .750MNPT br
78	60498	1	Fitting, plug-.750NPT square drive

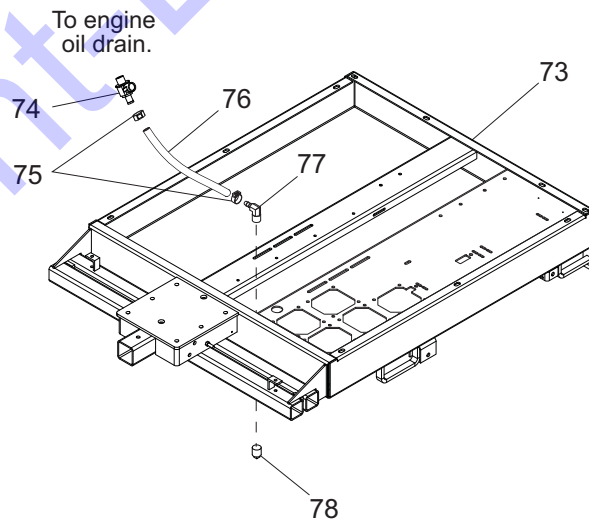

GENERATOR ASSEMBLY

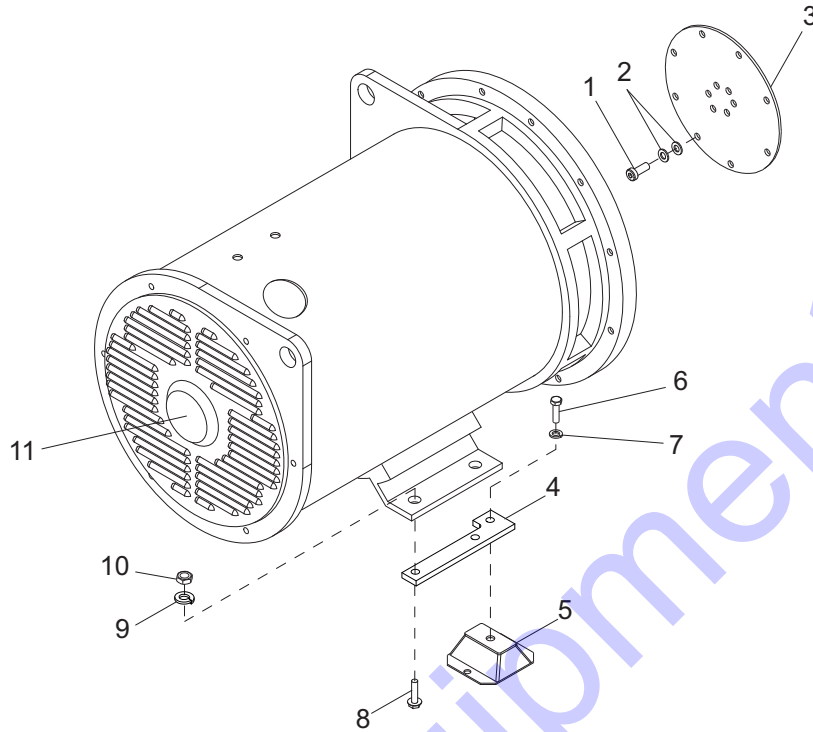

ITEM NO.	PART NO.	QTY	DESCRIPTION
1	60165	8	Screw, M8-1.25X16 std hex G10.9 LB
2	60166	16	Washer, M8 flat ZB DIN125 hardened TP200
3	11000	1	Plate, drive - SAE 7.5
4	11975B	2	Plate, gen adapter
5	11524	2	Compression mount, engine
6	60275	2	Screw, .500-13X1.000 hx hd G5
7	60702	2	Washer, .500 split lock SS
8	60065	4	Screw, M12-1.75X40 sflg hex G10.8 LB
9	60204	4	Washer, .500 split lock lb hvy
10	60013	4	Nut, M12-1.75 hex G8.8 LB DIN934
11	22899	1	Generator, 282NSL1505

Note: Engine and generator parts used in all Magnum Products LLC equipment carry the Original Equipment Manufacturer (OEM) warranty unless otherwise stated. OEM warranty parts must be purchased through an OEM dealer. Please contact Magnum Products LLC with questions.

MAST JUNCTION BOX ASSEMBLY - HARD WIRED LIGHTS

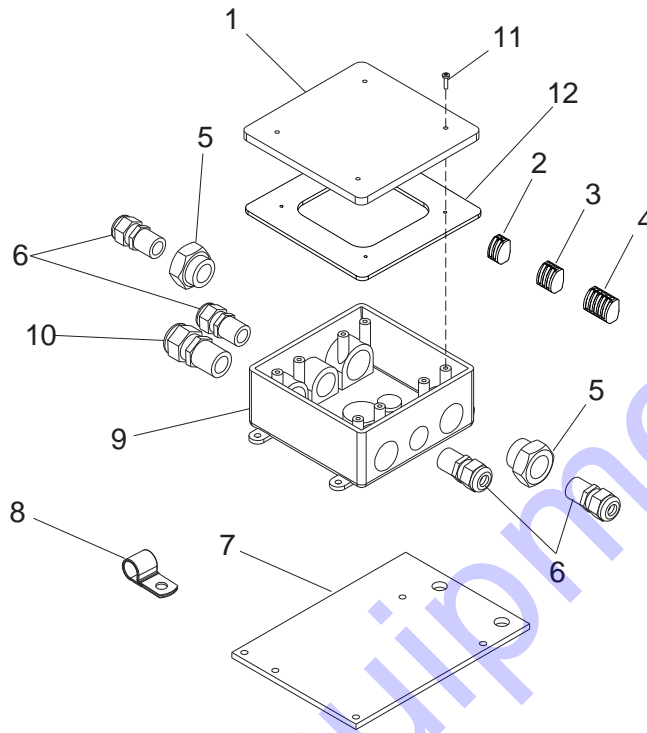

ITEM NO.	PART NO.	QTY	DESCRIPTION
1	12109	1	Box cover, 2-gang plastic
2	66100	4	Connector, 2 pos. Wago
3	66101	2	Connector, 3 pos. Wago
4	66102	1	Connector, 5 pos. Wago
5	60755	2	Fitting, .750MNPT x .500FNPT nylon
6	15864	4	Strain relief, .500NPT water tight
7	12095B	1	Bracket, junction box
8	16143	1	Clamp, tubing .500
9	12094	1	Box, junction
10	14656	1	Strain relief, .750NPT water tight
11	60424	4	Screw, 6-32X.750 pan phil G2 ZC self threading
12	13749	1	Gasket, junction box - HFI 281000
-	11789	-	Assembly, mast junction box

MAST JUNCTION BOX ASSEMBLY - QUICK DISCONNECT LIGHTS

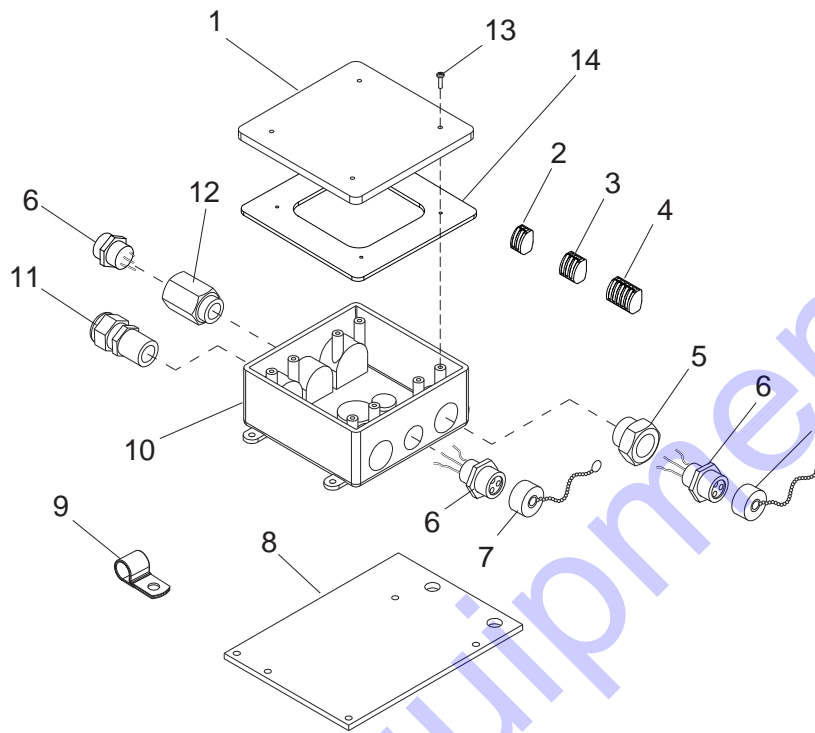

ITEM NO.	PART NO.	QTY	DESCRIPTION
1	12109	1	Box cover, 2-gang plastic
2	66100	4	Connector, 2 pos. Wago
3	66101	2	Connector, 3 pos. Wago
4	66102	1	Connector, 5 pos. Wago
5	60755	2	Fitting, .750MNPT x .500FNPT nylon
6	15403	4	Connector, quick disconnect (female)
7	15404	4	Cap, receptacle w/chain
8	12095B	1	Bracket, junction box
9	16143	1	Clamp, tubing .500
10	12094	1	Box, junction
11	14656	1	Strain relief, .750NPT water tight
12	12713	1	Fitting, adapter-1/2"-14 male to 1/2"-14 female
13	60424	4	Screw, 6-32X.750 pan phil G2 ZC self threading
14	13749	1	Gasket, junction box - HFI 281000
-	11957	-	Assembly, mast junction box

ENCLOSURE ASSEMBLY

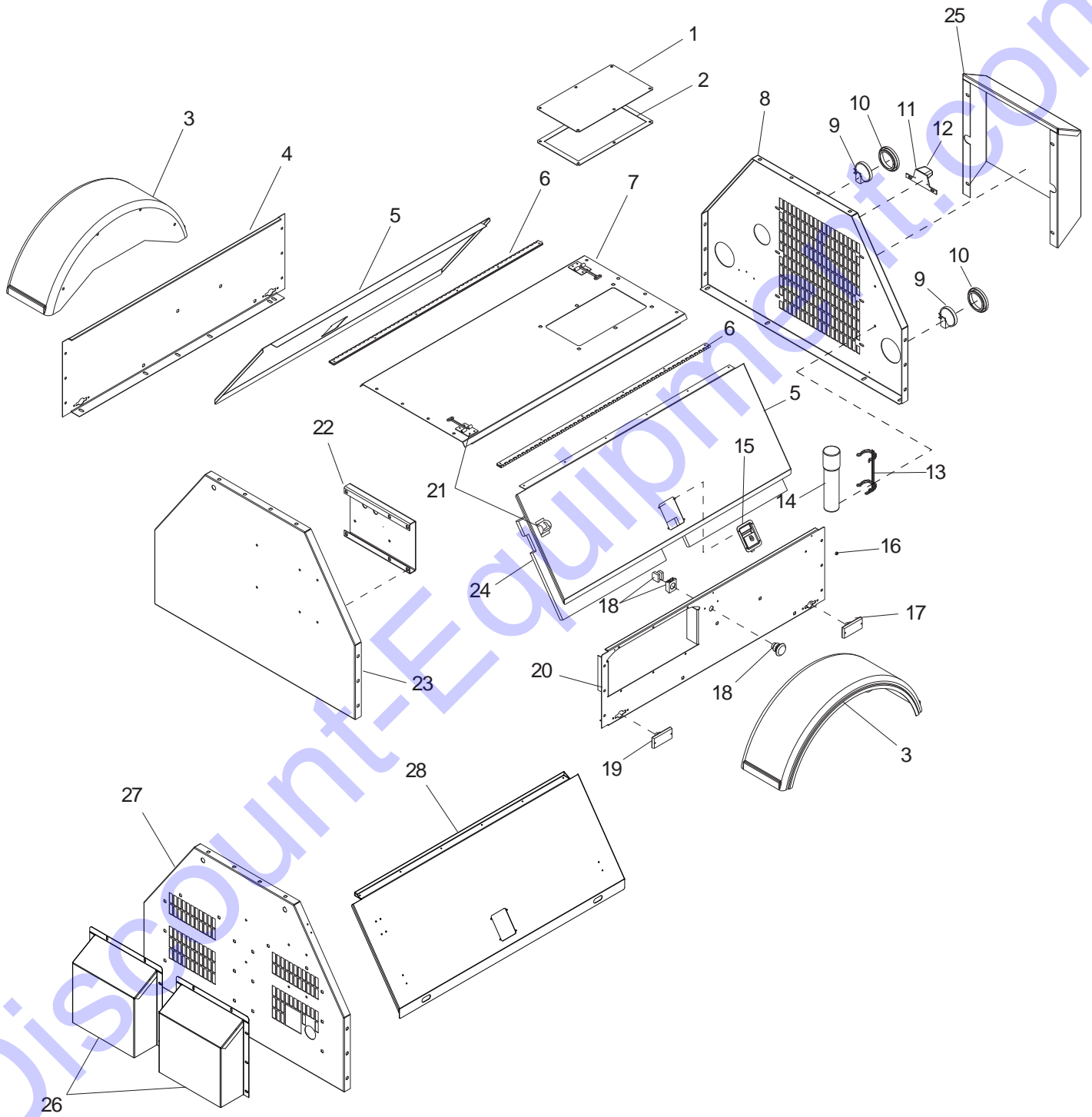

ITEM NO.	PART NO.	QTY	DESCRIPTION
1	25333W	1	Panel, back access
2	12195	1	Gasket, radiator access plate
3	11381	2	Fender, plastic
4	11507W	1	Panel, right side sheetmetal
5	16591W	2	Panel, door
6	16598	2	Hinge, door
7	10284W	1	Panel, roof w/access hole
8	10287W	1	Panel, rear 4000 Isuzu
9	10220	2	Light, rear tail/turn - no grommet
10	10221	2	Grommet, rear light rubber 4.5
	10219	2	Assembly, rear tail/turn light (9 & 10)
11	10224	1	Bracket, license plate
12	10225	1	Light, license bracket
	10223	1	Assembly, license plate light (11 & 12)
13	11222	1	Bracket, manual holder
14	11121	1	Holder, manual black tube
15	15123	2	Latch, paddle
16	15215	6	Bumper, rubber
17	65406	2	Light, clearance marker red
18	22550	1	Switch, Estop, 2NO/1NC
19	65407	2	Light, clearance marker amber
20	12257W	1	Panel, left side sheetmetal
21	12605	2	Door latch SS - T-style
22	11886B	1	Bracket, control box
23	12012W	1	Panel, front sheetmetal
24	11724	2	Foam, door
-	10222	-	Plug, rear light 3-wire MLT (not shown)
-	10226	-	Plug, 2-wire license light (not shown)

OPTIONAL FEATURES

For Containment/Silent Pack:

25	13101W	1	Duct, radiator guard
26	16469W	2	Duct, front
27	12754W	1	Panel, front 4000 containment
28	16739W	1	Panel, door - U bolt lock

AUXILIARY OUTLET PANEL ASSEMBLY

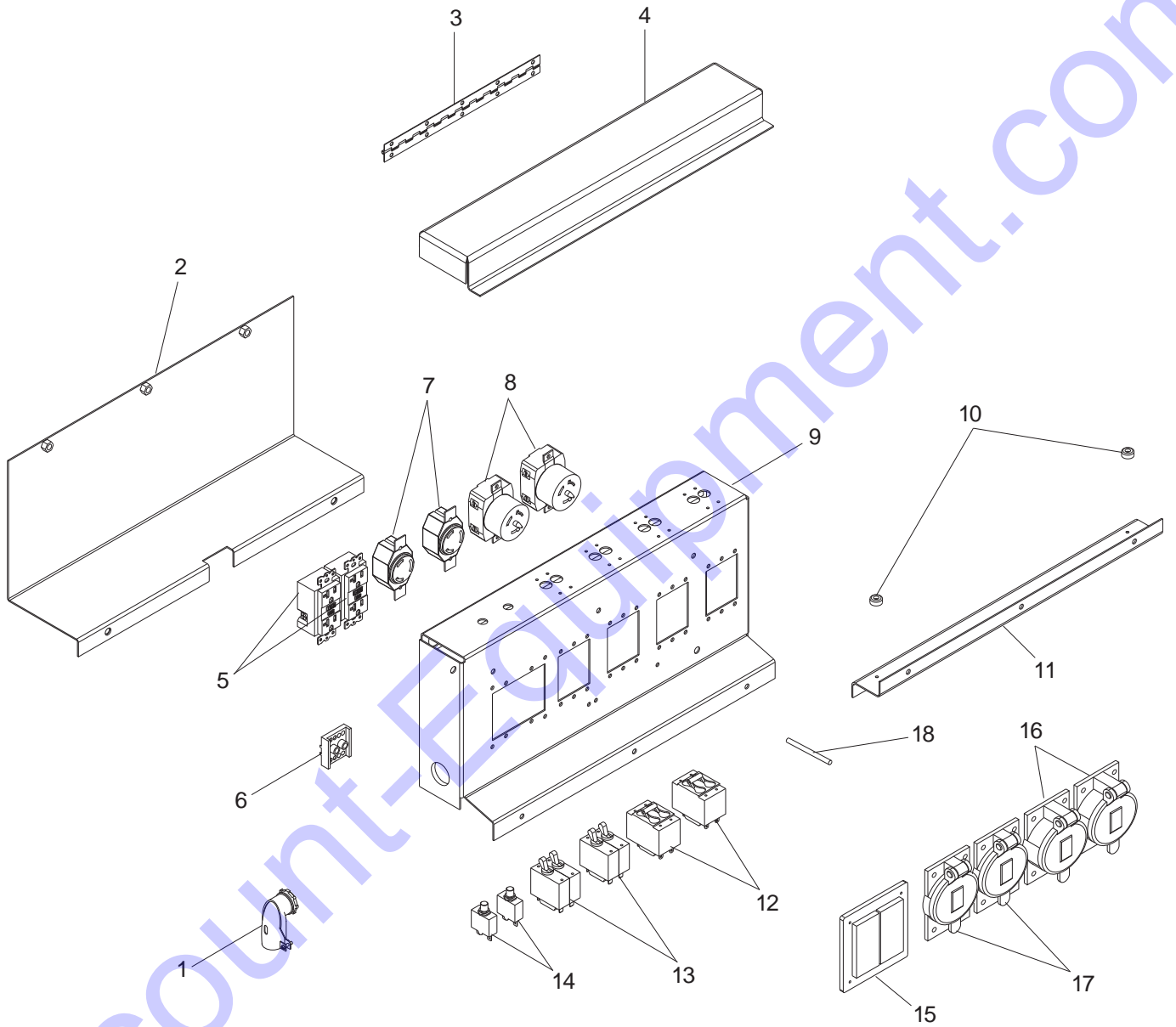

ITEM NO.	PART NO.	QTY	DESCRIPTION
1	65535	1	Clamp, 90° 3/4" 2 screw
2	12248B	1	Weldment, outlet cover
3	10081	1	Hinge, continuous - 11.00 in.
4	11484B	1	Cover, breaker
5	14130	2	Receptacle, 120V/20A GFCI
6	65530	2	Block, terminal - 2 pole lug type, 7 pos./pole
7	14137	2	Receptacle, 240V/30A twist lock
8	18089	2	Receptacle, 120/ 240V 50A twist lock
9	12246B	1	Weldment, outlet panel
10	15215	2	Rubber bumper
11	11485B	1	Angle, mounting support
12	65492	2	Breaker, 50A, 250V, 2 pole aux contact
13	65851	2	Breaker, 30A, 250V, 2 pole, screw term w/ aux
14	65849	2	Breaker, 20A, 120V, 1-pole, push button
15	15849	1	Cover, receptacle - weather proof
16	65467	2	Cover, receptacle 50A twist lock
17	65460	2	Cover, 20/30A 240V twist lock
18	18992	1	Stud, ground
-	12398	1	Receptacle panel (2x5-20R, 2xL6-30R, 2x50A)

AUXILIARY OUTLET PANEL OPTIONS

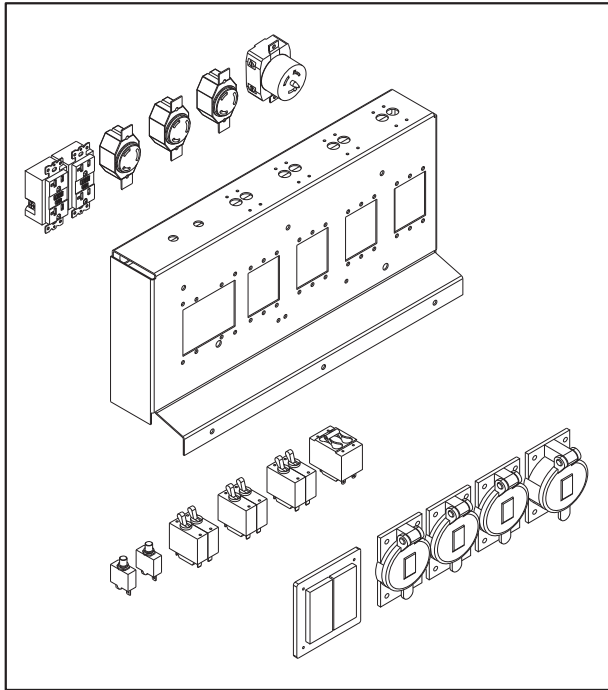

PART NUMBER 12399
Receptacle Panel (2x5-20R, 3xL6-30R, 1x50A)

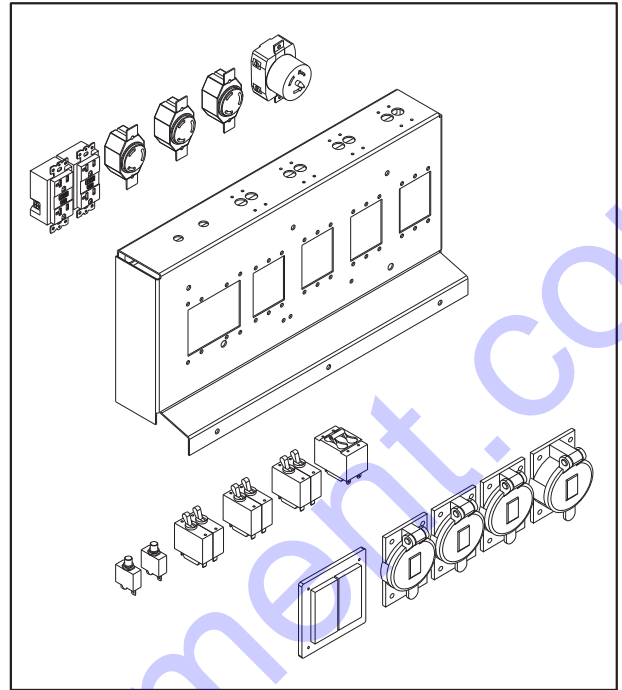

PART NUMBER 12402
Receptacle Panel (2x5-20R, 3xL6-20R, 1x50A)

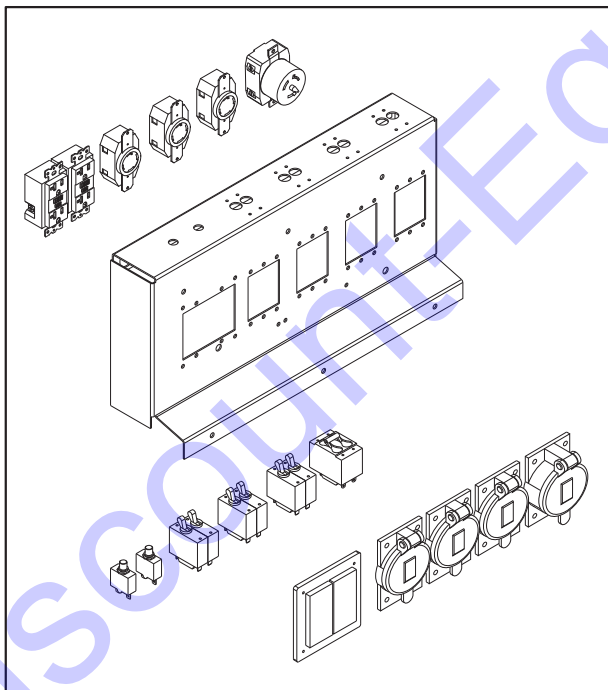

PART NUMBER 12400
Receptacle Panel (2x5-20R, 3xL14-30R, 1x50A)

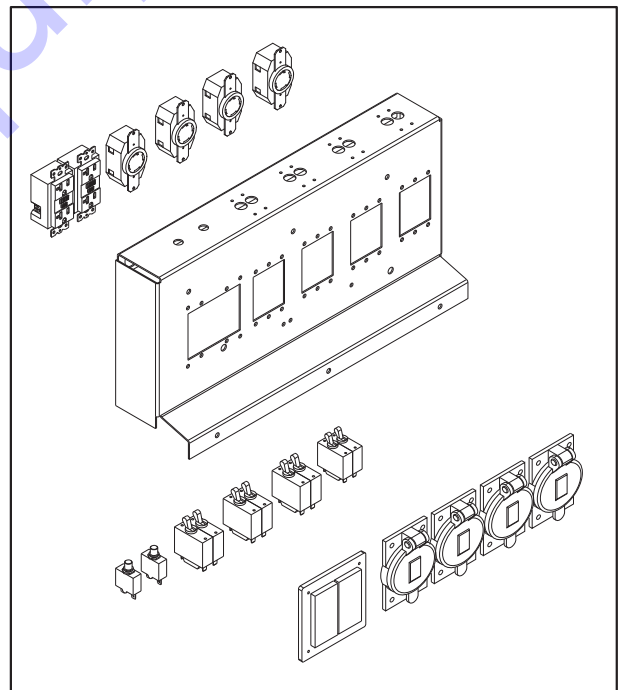

PART NUMBER 12401
Receptacle Panel (2x5-20R, 4xL14-30R)

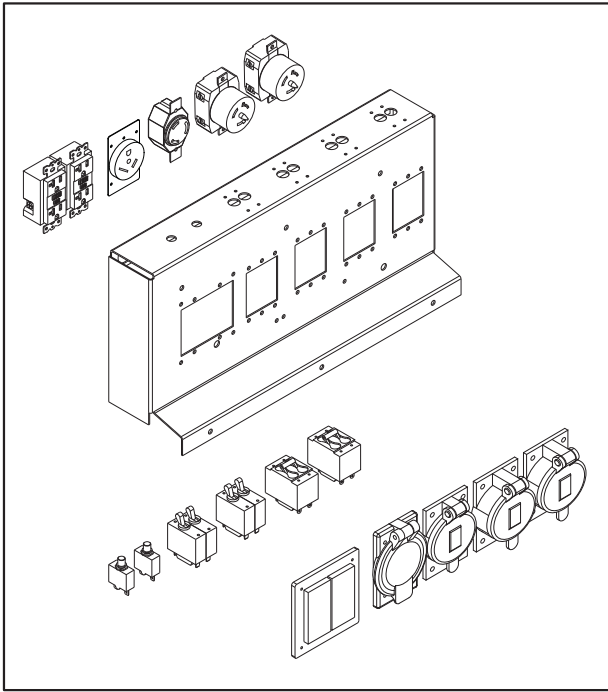

PART NUMBER 13540

Receptacle Panel (2x5-20R, 1xTT-30R, 1xL6-30R, 2x50A)

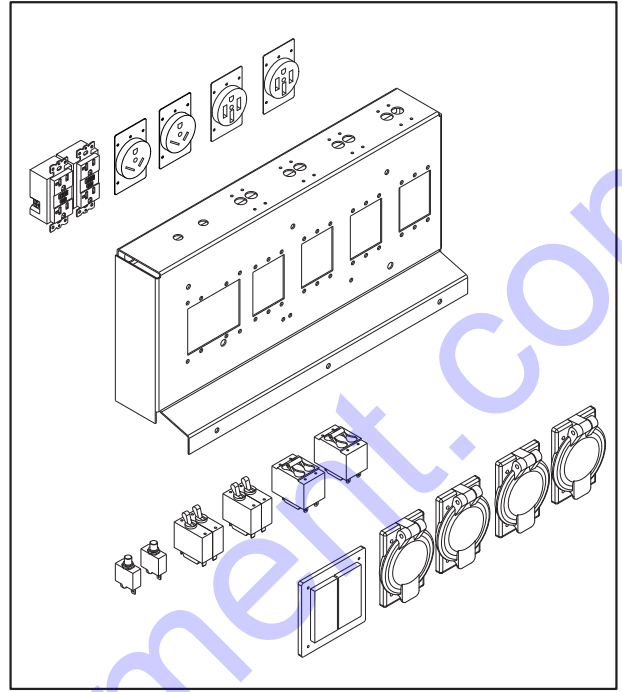

PART NUMBER 13893

Receptacle Panel (2x5-20R, 2xTT-30R, 2x14 - 50)

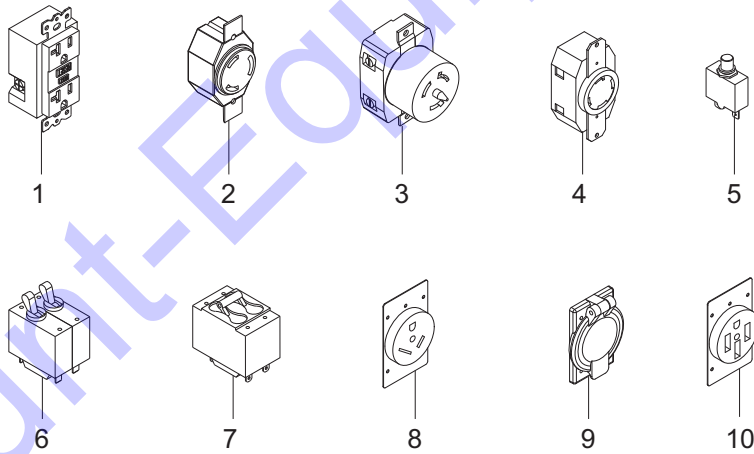

ITEM NO.	PART NO.	QTY	DESCRIPTION
1	14130	2	Receptacle, 120V 20A GFCI
2	14137	-	Receptacle, 240V 30A twist lock
3	18089	-	Receptacle, 125/250V 50A twist lock
4	65488	-	Receptacle, 240V 30A twist lock
5	65849	2	Breaker, 20A, 120V, 1 pole, push button
6	65851	2	Breaker, 30A 250V 2 pole (JA) screw term, w/aux
7	65492	-	Breaker, 50A 250V 2 pole aux contact
8	65489	1	Receptacle, 120V/30A (TT-30R) (RV)
9	65520	1	Cover, receptacle - weather proof 50A 3-wire
10	65815	-	Receptacle, 240V/50A (14-50R) (RV)

OVAL LIGHT ASSEMBLY

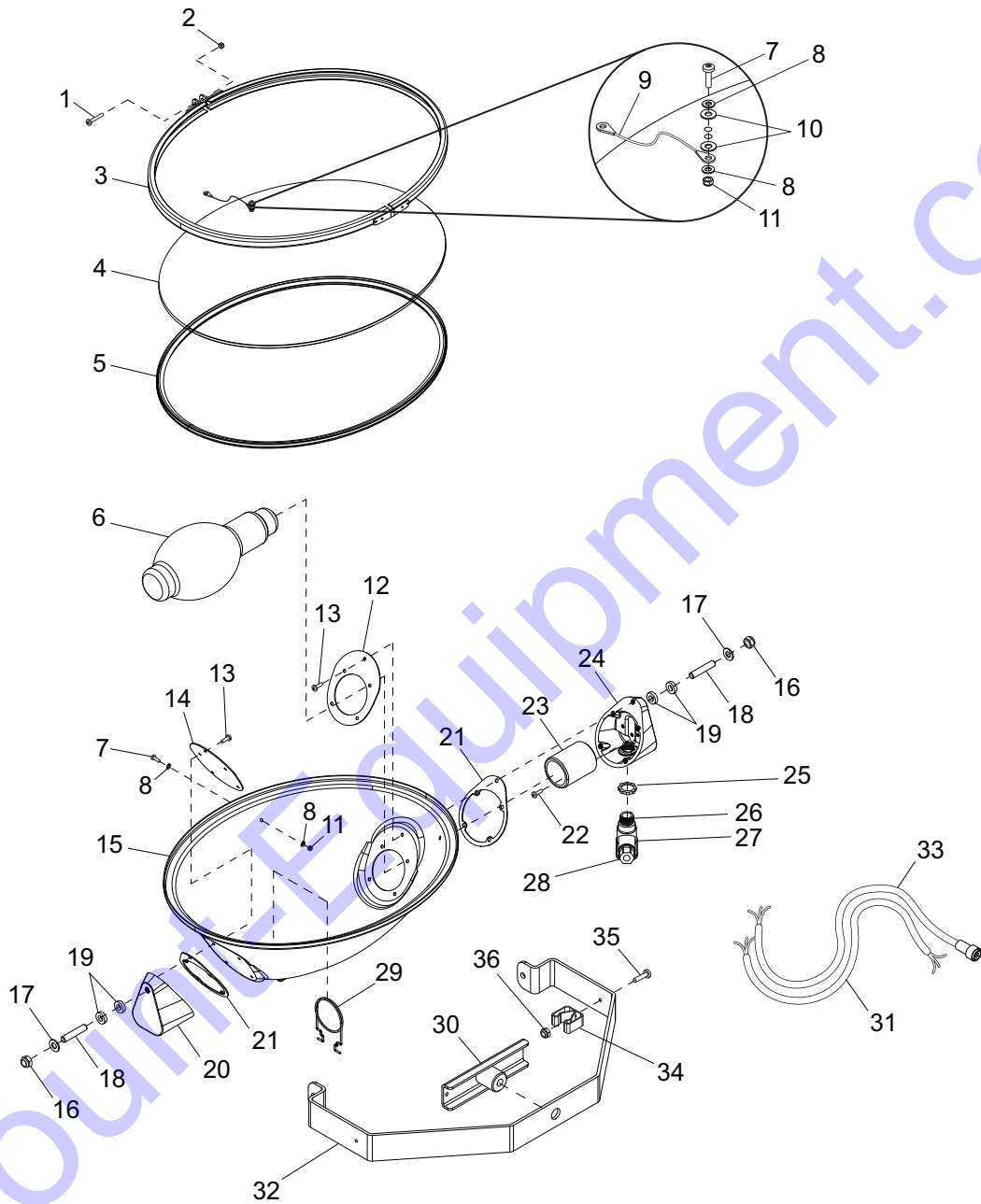

ITEM NO.	PART NO.	QTY	DESCRIPTION
1	60304	1	Screw, M5 x 25 pan hd phillips
2	60447	1	Nut, M5 nylock
3	13367	1	Assembly, aluminum ring
4	13369	1	Lens, glass oval
5	13373	1	Gasket, lens oval
6	11391	1	Bulb, 1000W MH short length
7	13399	2	Screw, M4 x 18 pan hd phillips
8	60067	4	Washer, #10 flat .435/.060 SS
9	13370	1	Assembly, tether
10	13372	2	Washer, #4 nylon
11	60051	2	Nut, M4 nylock
12	13376	1	Bracket, socket end plate
13	13388	10	Screw, M5 x 12 slotted hex w/flange
14	13377	1	Bracket, end plate
15	13366	1	Housing
16	60307	2	Nut, 500-13 nylk G5 ZC
17	60309	2	Washer, .500 flat 1.060/.090 ZC SAE
18	13392	2	Stud, trunnion
19	13390	4	Washer, nylon (for part number 13392)
20	13374	1	Support, housing/trunnion
21	13378	2	Gasket, silicone
22	13393	2	Screw, M5 x 12 phillips green
23	13381	1	Socket, bulb
24	13375	1	Support, housing/trunnion
25	15861	1	Nut, special, .500 NPT lock (LN101SC)
26	13386	1	Fitting, nipple
27	13387	1	Connector, weather tight
28	15864	1	Strain relief, .50 NPT watertight .270/.464 ID
29	13892	1	Support, bulb - oval light
30	13403	1	Handle, T - oval light (wing nut)
31	13438	1	Cord, power hard wired
32	13368	1	Trunnion, oval light
--	13311	4	Assembly, light fixture - 1000W hard wired oval
OPTIONAL FEATURES:			
33	13383	1	Cord, power quick disconnect
34	19041	1	Clip, spring holder
35	60398	1	Screw, 10-32X.500 pan phil18-8 ss
36	60061	1	Nut, 10-32 nylk G5
--	13601	4	Assy, light fixture/quick disconnect cord clip

ENGINE COOLING ASSEMBLY

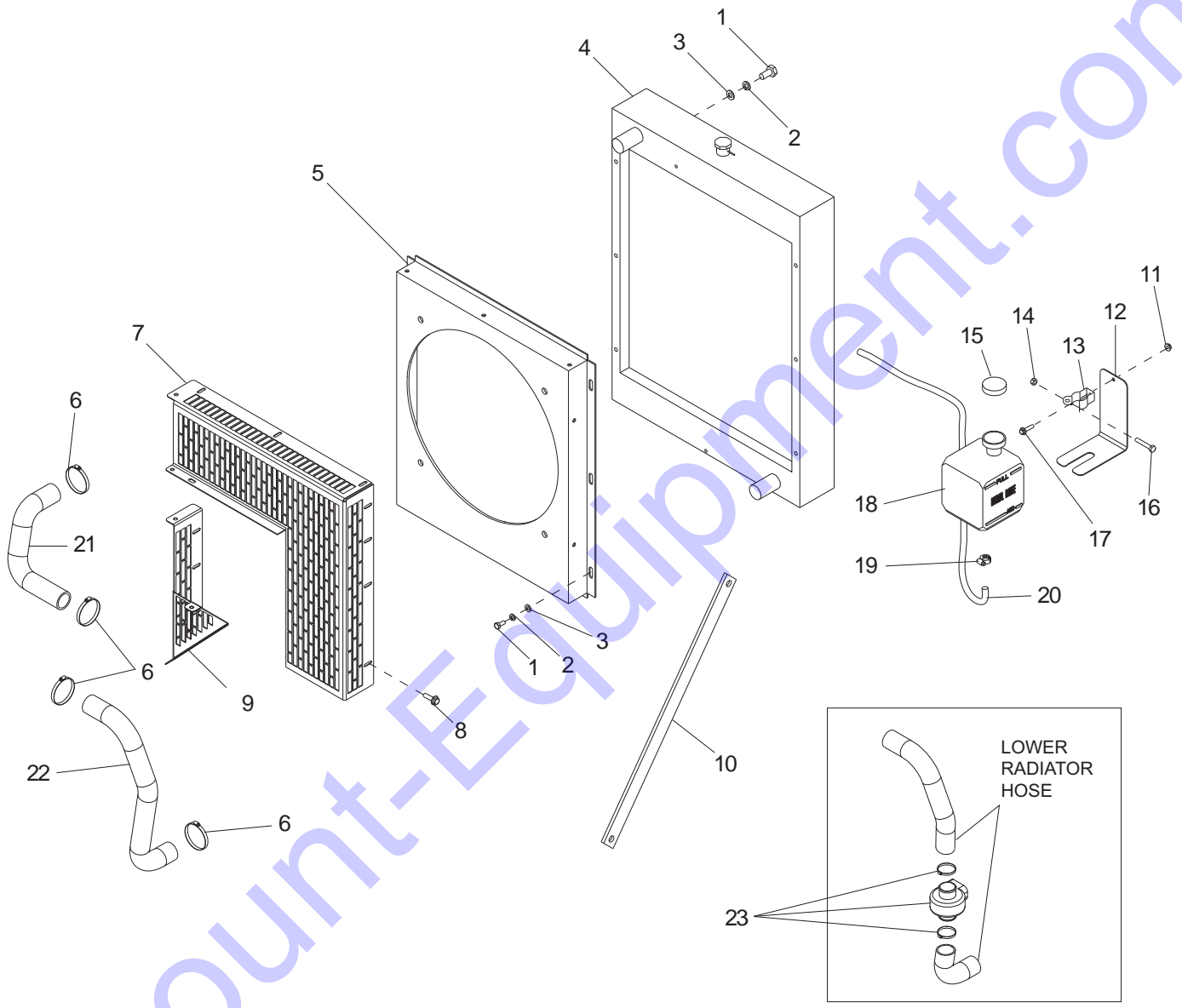

ITEM NO.	PART NO.	QTY	DESCRIPTION
1	60034	12	Screw, .375-16X.750 hx ser flg
2	60206	12	Washer, split lock .375
3	60386	1	Washer, flat .375
4	26305	1	Radiator, aluminum
5	11626B	1	Weldment, fan shroud
6	15422	4	Clamp, hose SAE 20
7	11760B	1	Panel, fan guard - right
8	60115	8	Screw, M6X1.0X12 hx ser flg
9	11769B	1	Weldment, fan guard - left
10	11596B	1	Strut, radiator support
11	60144	1	Nut, .250-20 nylock
12	22419B	1	Bracket, support overflow jug .5 gal.
13	19726	1	Clamp, overflow bottle
14	60047	1	Nut, M6 hx lock class 6 DIN985
15	19714	1	Cap, overflow bottle
16	60014	1	Screw, M6X1.0X35 hx GR8.8 DIN933
17	60135	1	Screw, M6X1.0X20 hx ser flg
18	20287	1	Jug, overflow 2 qt. (.5 gal.)
19	14216	1	Clamp, hose SAE 04
20	19220	1	Hose, overflow
21	12064	1	Hose, radiator upper
22	12356	1	Hose, radiator lower
OPTIONAL FEATURES			
23	65650	1	Heater, engine - low rad hose 1.5"

ENGINE ASSEMBLY

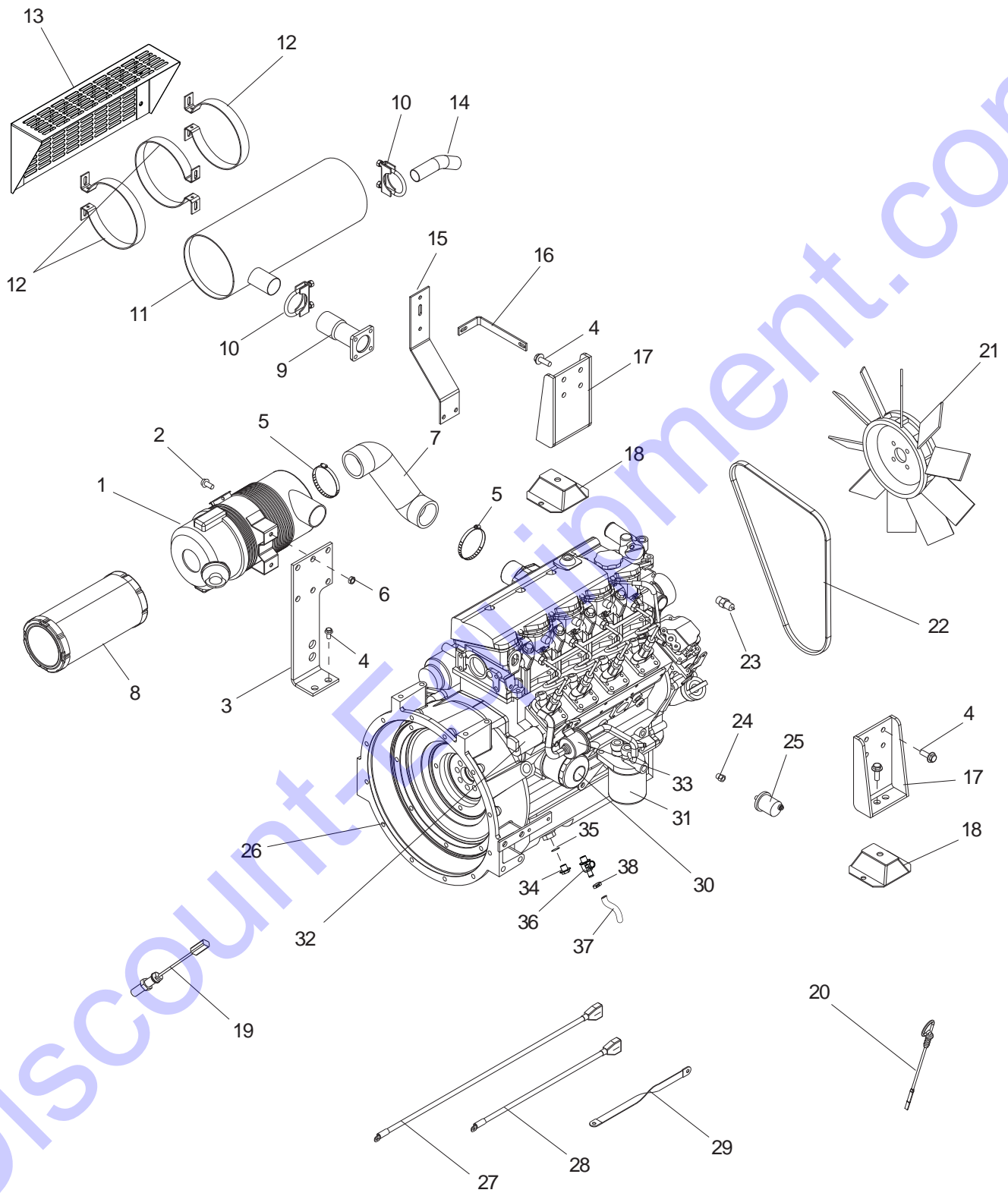

ITEM NO.	PART NO.	QTY	DESCRIPTION
1	21505	1	Assembly, air filter
2	60009	4	Screw, M8X1.25X25 hx ser flg
3	12990B	1	Bracket, air filter
4	60018	14	Screw, M10X1.25X20 hx ser flg
5	60316	2	Clamp, hose - SAE 32
6	60342	4	Nut, M8X1.25 hx GR8.8 SS
7	22320	1	Hose, air filter
8	21937	1	Element, air filter - 12" filter
9	12421B	1	Weldment, exhaust flange
10	25455	2	Clamp, 1.5" muffler
11	12608	1	Muffler
12	12606B	3	Bracket, muffler
13	12612B	1	Heat shield
14	12683B	1	Pipe, exhaust
15	12634B	1	Bracket, muffler mounting
16	12635B	1	Bracket, muffler support
17	11471B	2	Weldment, engine mount
18	11524	2	Compression mount, 4.38x4.00x1.50
19	18105	1	Sensor, magnetic pick-up
20	23899	1	Dipstick, oil, Isuzu 4LE
21	19258	1	Fan, 15.75 in.
22	22258	1	Belt, fan - 4LE1
23	19247	1	Sensor, temperature (small)
24	19232	1	Fitting, .125NPTF X .125-28 BSP male
25	18106	1	Sensor, oil pressure
26	21674	1	Engine, Isuzu 4LE1NYGV-01, with #5 SAE BH
27	15074	1	Cable, battery - 4 AWG X 38 in. red
28	15073	1	Cable, battery - 4 AWG X 25 in. blk .38 lug
29	19042	1	Strap, braided ground - 10 in.
30	15183	1	Filter, oil - Isuzu (3LB,3LD,4LE)
31	15331	1	Fuel filter element
32	15372	1	Solenoid, fuel shutdown
33	16205	1	Pump, fuel - Isuzu 4LE1
34	11040	1	Isuzu, plug, oil pan
35	11041	1	Isuzu, oil plug gasket
-	26049	1	Alternator (not shown)
-	26033	1	Starter assembly (not shown)

OPTIONAL FEATURES:

36	11952	1	Valve, drain - 20X1.5MM thread/barb
37	50051	.25 ft.	Hose, fuel - .375 ID 50 PSI SAE 30R7
38	60777	1	Clamp, hose - .312 fuel hose crimp style
<i>For Containment/Silent Pack Option:</i>			
-	26306	1	Fan, 15.75 in. increasing arc (not shown)

Note: Engine and generator parts used in all Magnum Products LLC equipment carry the Original Equipment Manufacturer (OEM) warranty unless otherwise stated. OEM warranty parts must be purchased through an OEM dealer.

CONTROL PANEL ASSEMBLY

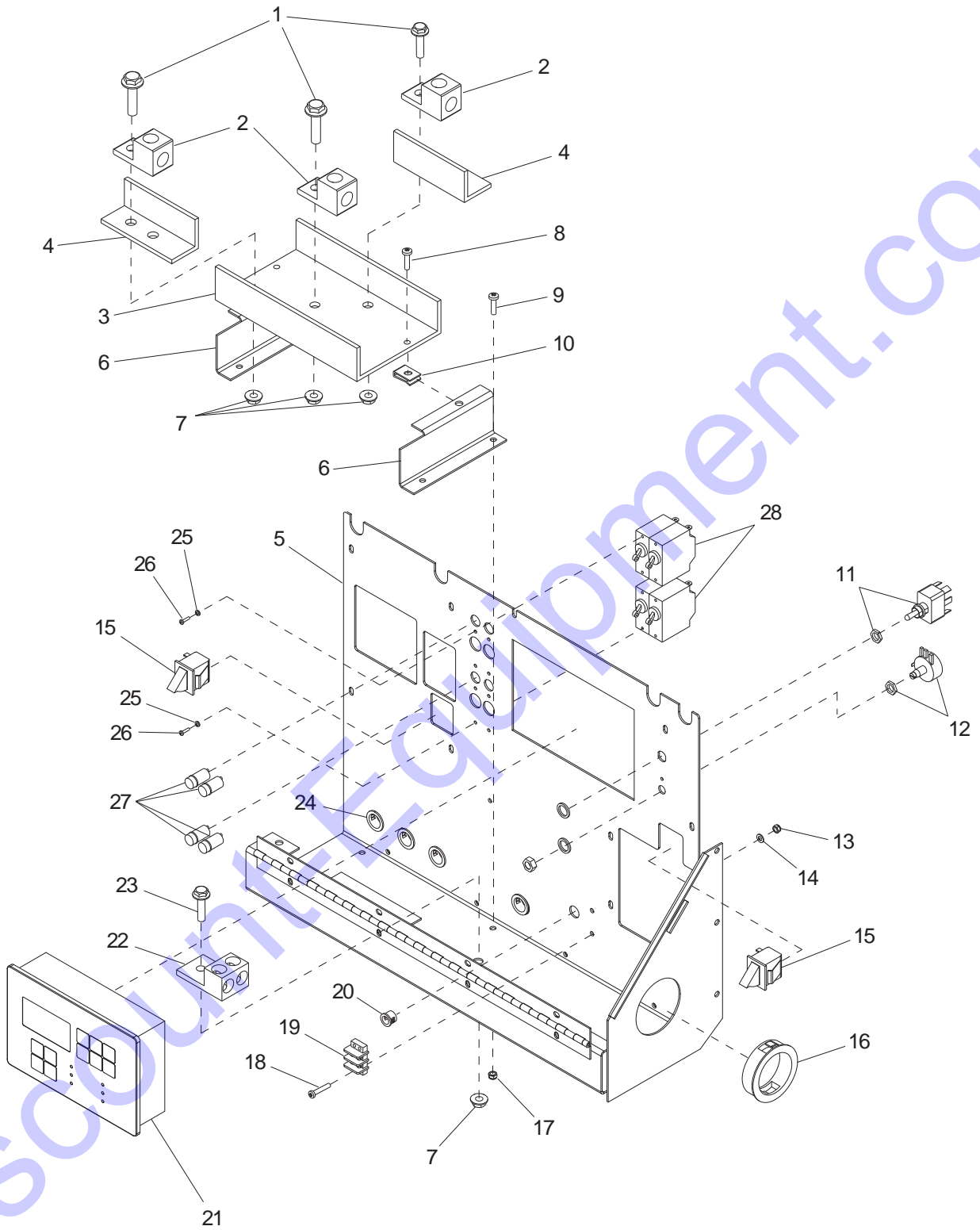

ITEM NO.	PART NO.	QTY	DESCRIPTION
1	60160	3	Screw, M8X1.25X30 hx ser flg
2	65287	3	Lug, terminal single #6-350 MCM
3	12065	1	Channel, glastic
4	12066	2	Angle, glastic
5	13126W	1	Panel, control
6	11811W	2	Bracket, glastic plate
7	60020	7	Nut, M8 hx ser flg lock
8	60062	3	Screw, 10-32X.750 pan hd phil
9	60044	2	Screw, M5X0.8X12 pan hd phil
10	60738	2	Nut, 10-32 speed u-type
11	25077	1	Switch, toggle - SPST 20A VAC
12	18113	1	Potentiometer, 2.5K 2 watt
13	60057	4	Nut, M4 hx hd
14	60084	2	Washer, flat M4
15	12632	2	Switch, trigger safety, N.O. & N.C.
16	18496	1	Bushing, 2.50 x 2.00 ID
17	60038	4	Nut, M5 HX nylock
18	60355	2	Screw, M4X25 pan hd phil
19	18890	1	Terminal block, 2-pos
20	19163	1	Bushing, .500 x .375 ID
21	66186	1	Controller, eng/gen - programmed
22	18614	1	Lug, terminal dual #6-250MCM 2 hole
23	60009	3	Screw, M8X1.25X25 hx ser flg
24	19227	4	Bushing, .812 OD x .625 ID
25	60058	8	Washer, #6 split lock
26	60190	8	Screw, 6-32X.312 pan phil
27	65325	4	Light, indicator - green w/ wire
28	14249	4	Breaker, 15A 250V 1pole
-	18934	1	Guard, potentiometer (not shown)
-	12628	1	Assembly, control panel (complete)

CONTROL BOX ASSEMBLY

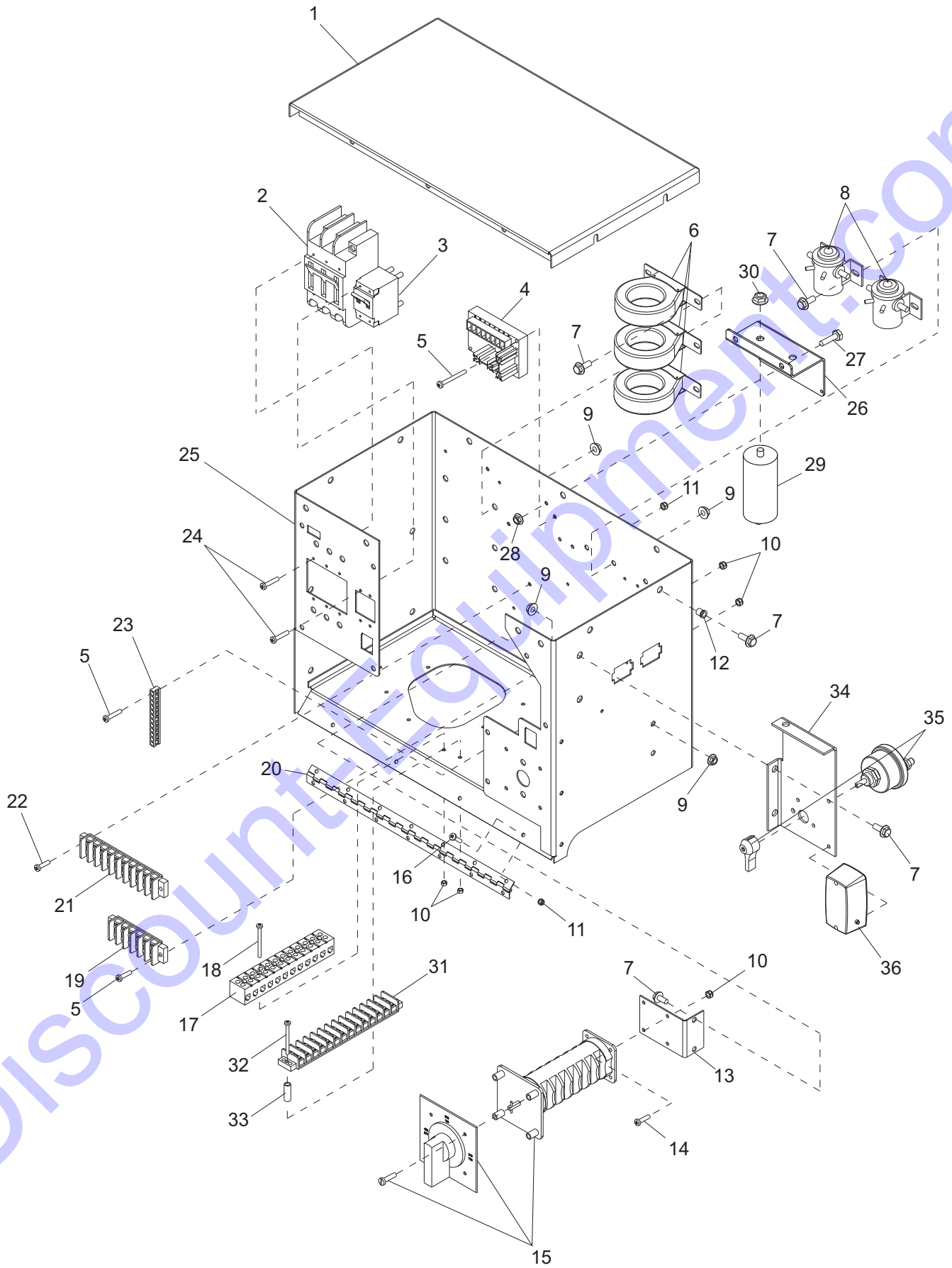

ITEM NO.	PART NO.	QTY	DESCRIPTION
1	12694W	1	Panel, top control box
2	65619	1	Breaker, 90A, 3 pole
3	65429	1	Breaker, 100A, 250V, 2 pole
4	18556	1	Regulator, voltage - SE 350
5	60355	6	Screw, M4X35 pan head phil
6	65442	3	Transformer, current - 200:5A
7	60115	25	Screw, M6X1.0X12 hx ser flg
8	18081	2	Relay, ignition solenoid (12V-65 A)
9	60036	14	Nut, M6 hx ser flg lock
10	60051	13	Nut, M4 hx nylock
11	60061	6	Nut, 10-32 hx nylock
12	60023	11	Insert, threaded M6
13	11764B	1	Bracket, phase switch
14	60091	4	Screw, M4X12 pan hd phil
15	65456	1	Switch, phase - 63A, 3-pos (Y,y,Z)
16	60044	4	Screw, M5X0.8X12 pan hd phil
17	65590	1	Block, terminal - 12 pos. lug type
18	60045	3	Screw, M4X35 pan hd phil
19	65481	1	Block, terminal - 6 pos.
20	18598	1	Hinge, controller panel - 18.75
21	14203	1	Block, terminal 10 pos.
22	60062	2	Screw, 10-32X.750 pan hd phil
23	14204	1	Kit, ground bar
24	60190	10	Screw, 6-32X.312 pan hd phil
25	13137W	1	Weldment, control box
26	13343B	1	Bracket, dual cap mount
27	60168	2	Screw, .312-18X.750 hx hd G5
28	60095	2	Nut, .312-18 ser flg G5 case hard
29	65959	2	Capacitor, dual 24 μ F sealed stud mount
30	60098	2	Nut, .500-13 ser flg G5
31	66013	1	Terminal block, 14 pos.
32	24925B	2	Spacer, .50 OD .344 ID 1.00 long, black
33	60159	2	Screw, M4-0.70X45 pan phil G4.8
-	12625	1	Assembly, control box enclosure
-	12624	1	Assembly, control box (complete)
OPTIONAL FEATURES:			
34	12021B	1	Bracket, control box roof (optional)
35	65498	1	Switch, disconnect (optional)
36	11947	1	Light, interior with switch (optional)

LUG DOOR ASSEMBLY

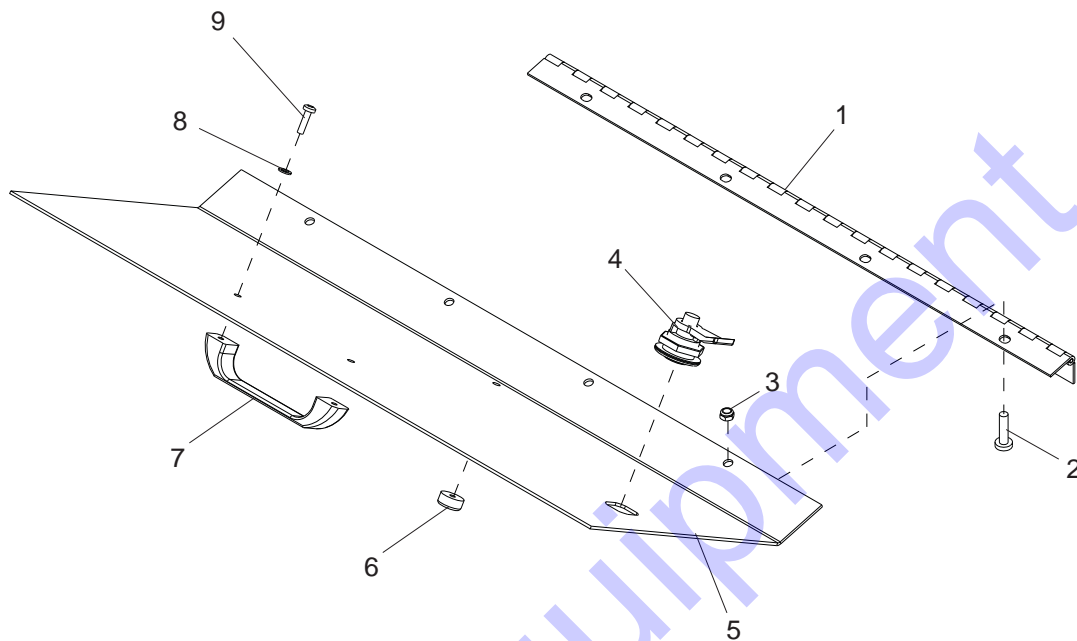

ITEM NO.	PART NO.	QTY	DESCRIPTION
1	18598	1	Hinge, controller panel - 18.75
2	60156	8	Screw, M5X0.8X16 pan hd phil
3	60038	4	Nut, M5 hx nylock DIN985
4	20762	1	Lock, door - 1/4 turn cam
5	12631W	1	Panel, lug door
6	15215	1	Bumper, rubber
7	18893	1	Handle, lug door
8	60043	2	Washer, split lock M5 DIN127
9	60068	2	Screw, 10-24X.500 pan phil
-	12630	1	Assembly, lug door

TRAILER LIGHTS WIRING DIAGRAM

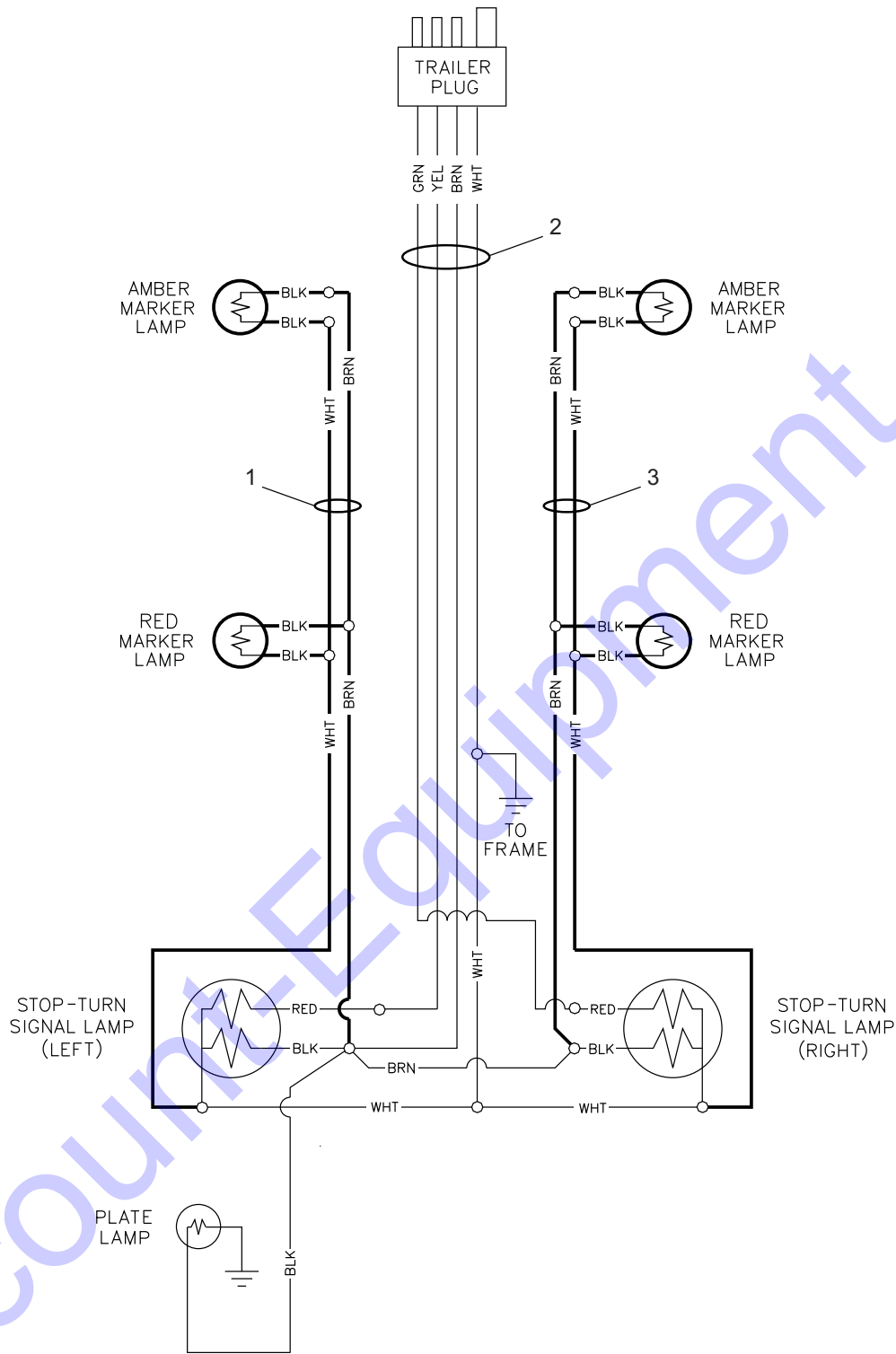

ITEM NO.	PART NO.	QTY	DESCRIPTION
1	10264	1	Harness, left side trailer
2	10261	1	Harness, main trailer 4000
3	10265	1	Harness, right side trailer
-	65465	-	Adapter, trailer wiring flat 4 to rnd 7 blade
-	65464	-	Adapter, trailer wiring flat 4 to rnd 7 pin
-	65463	-	Adapter, trailer wiring flat 4 to rnd 6 pin

AC WIRING DIAGRAM

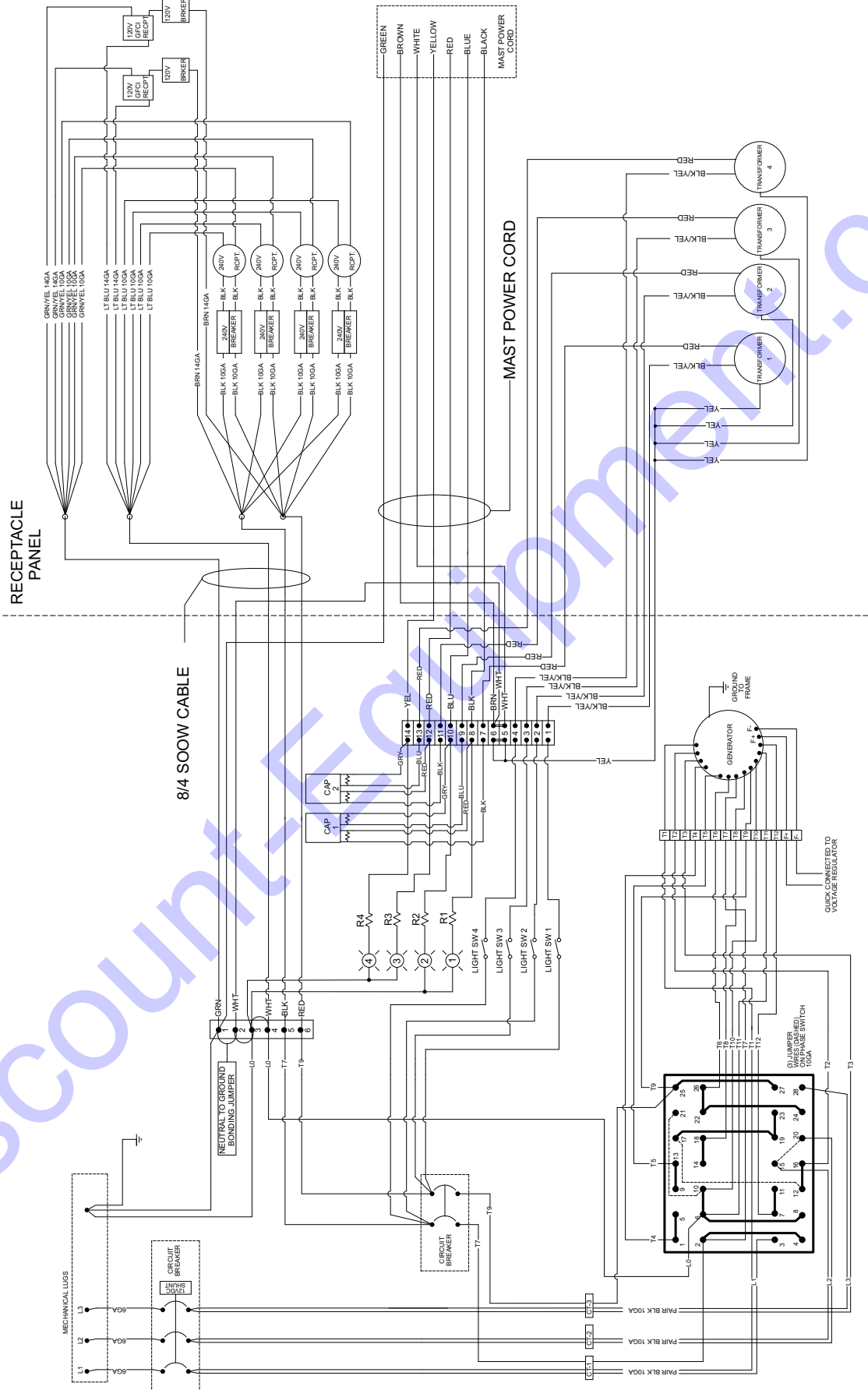

DC WIRING DIAGRAM

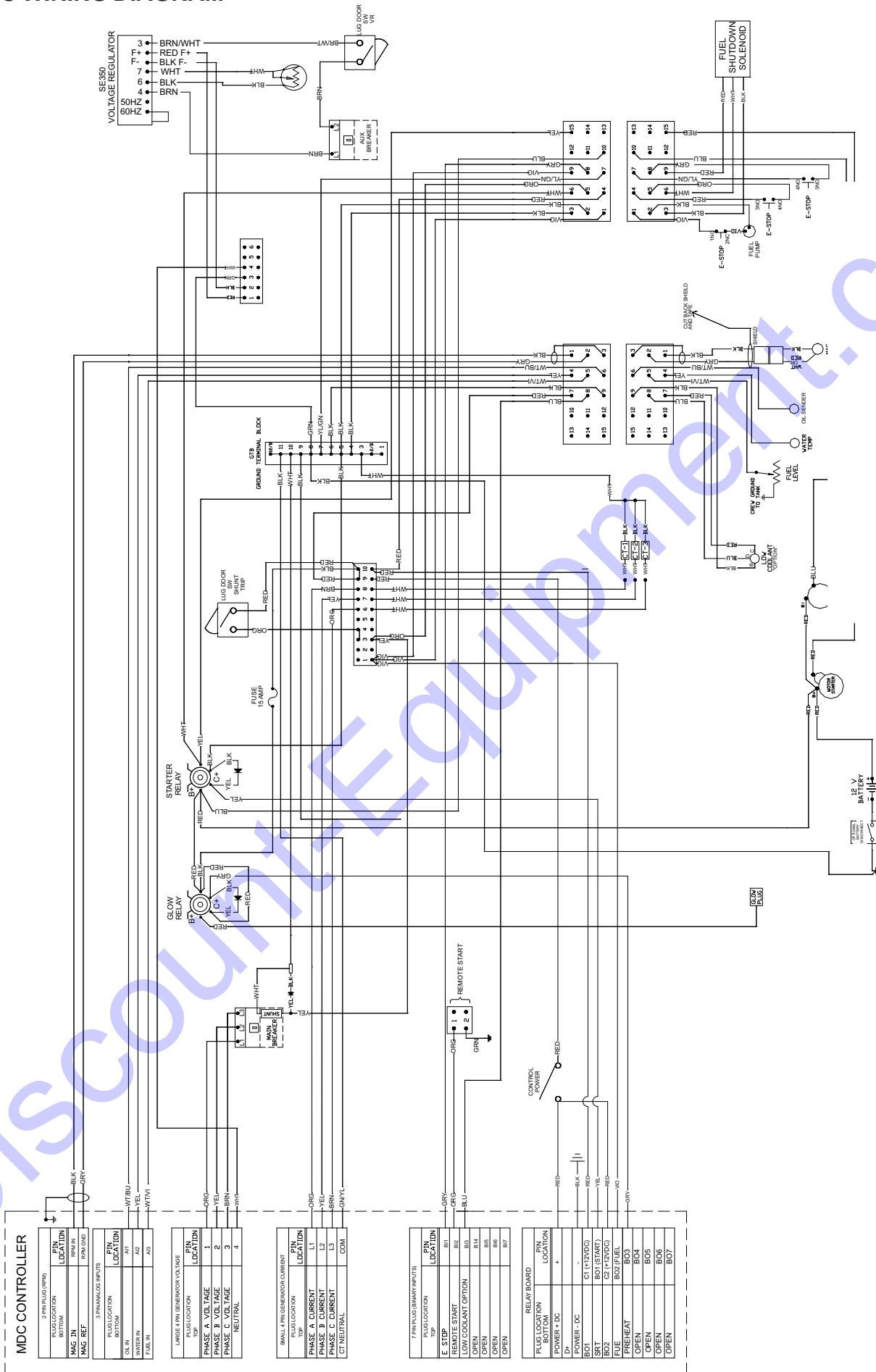

90215, ORG 8.07.08

AC WIRING PANEL OPTIONS

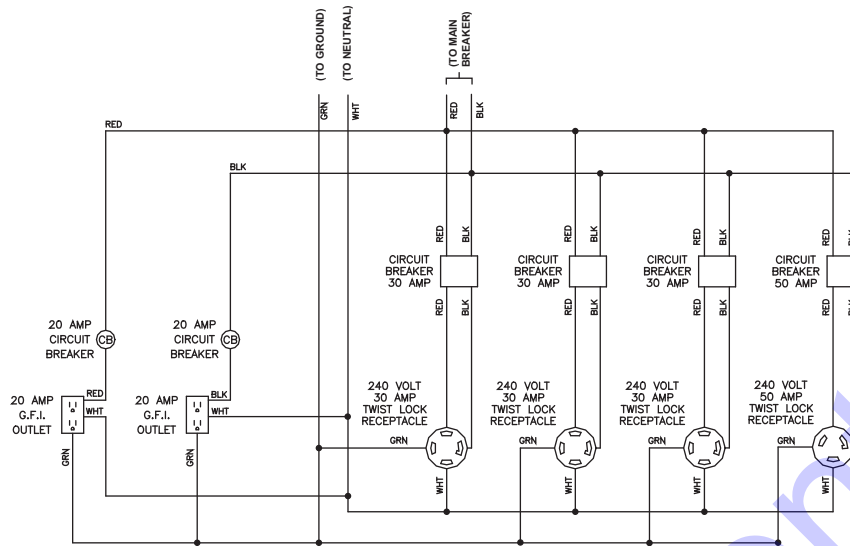

PART NUMBER 12399; Receptacle Panel (2x5-20R, 3xL6-30R, 1x50A)

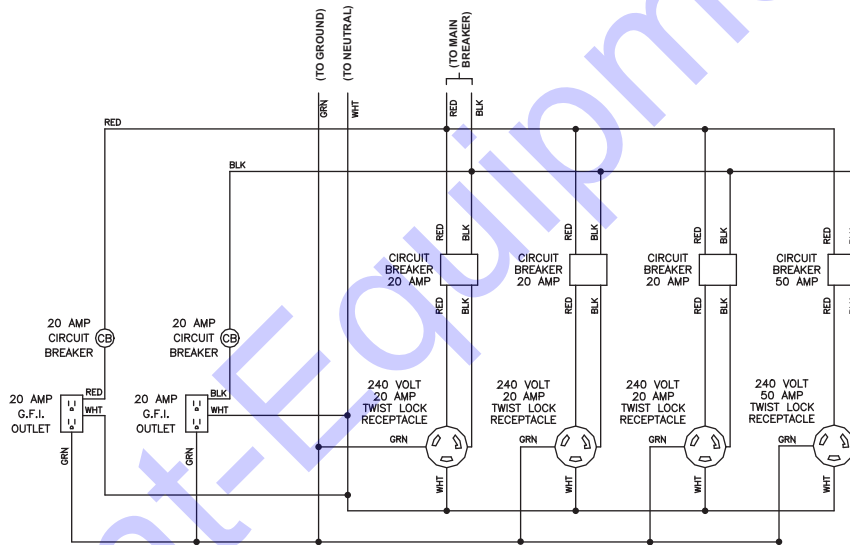

PART NUMBER 12402; Receptacle Panel (2x5-20R, 3xL6-20R, 1x50A)

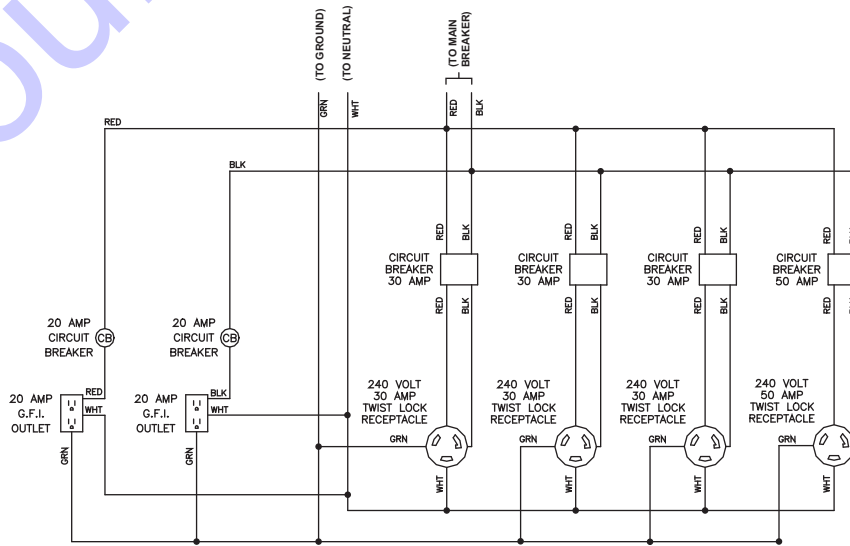

PART NUMBER 12400; Receptacle Panel (2x5-20R, 3xL14-30R, 1x50A)

AC WIRING PANEL OPTIONS

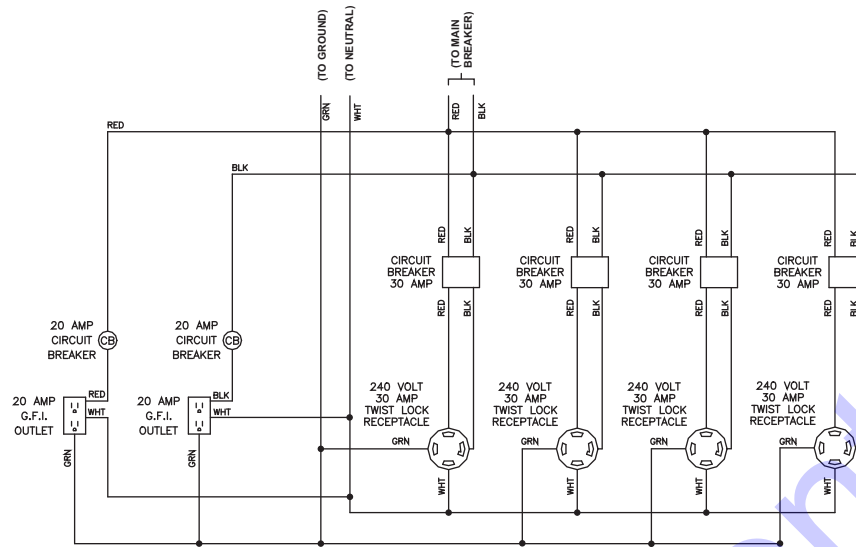

PART NUMBER 12401; Receptacle Panel (2x5-20R, 4xL14-30R)

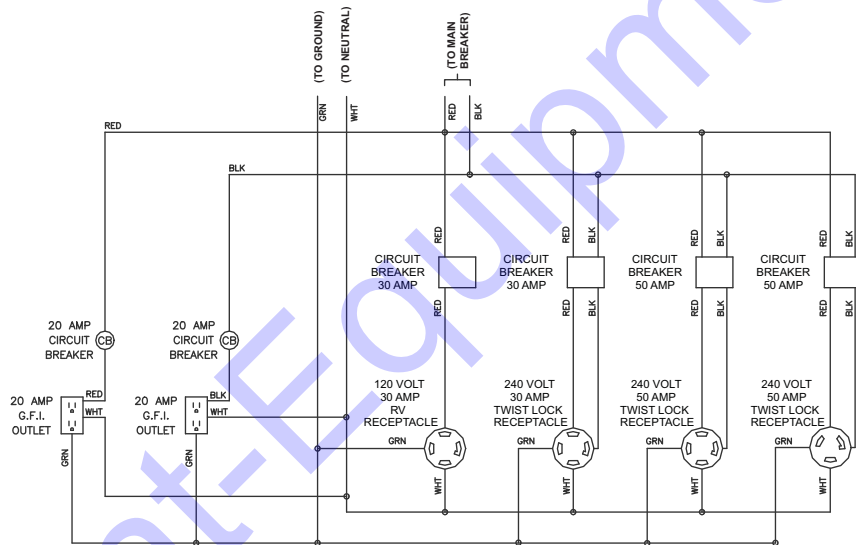

PART NUMBER 13540; Receptacle Panel (2x5-20R, 1xTT-30R, 1xL6-30R, 2x50A)

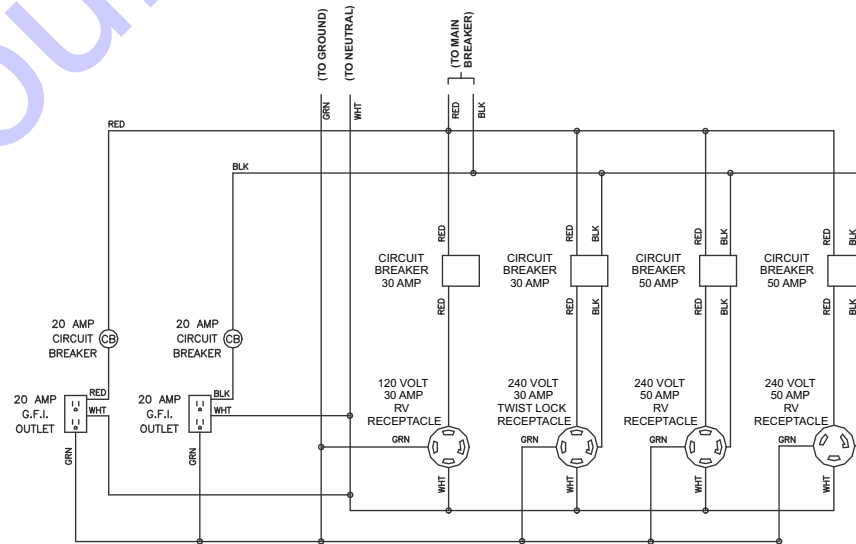

PART NUMBER 13893; Receptacle Panel (2x5-20R, 2xTT-30R, 2x14-50)

DC CIRCUIT WIRING DIAGRAM, DUAL ELECTRIC WINCH

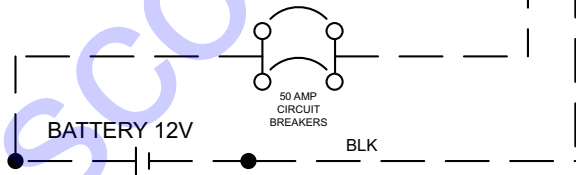
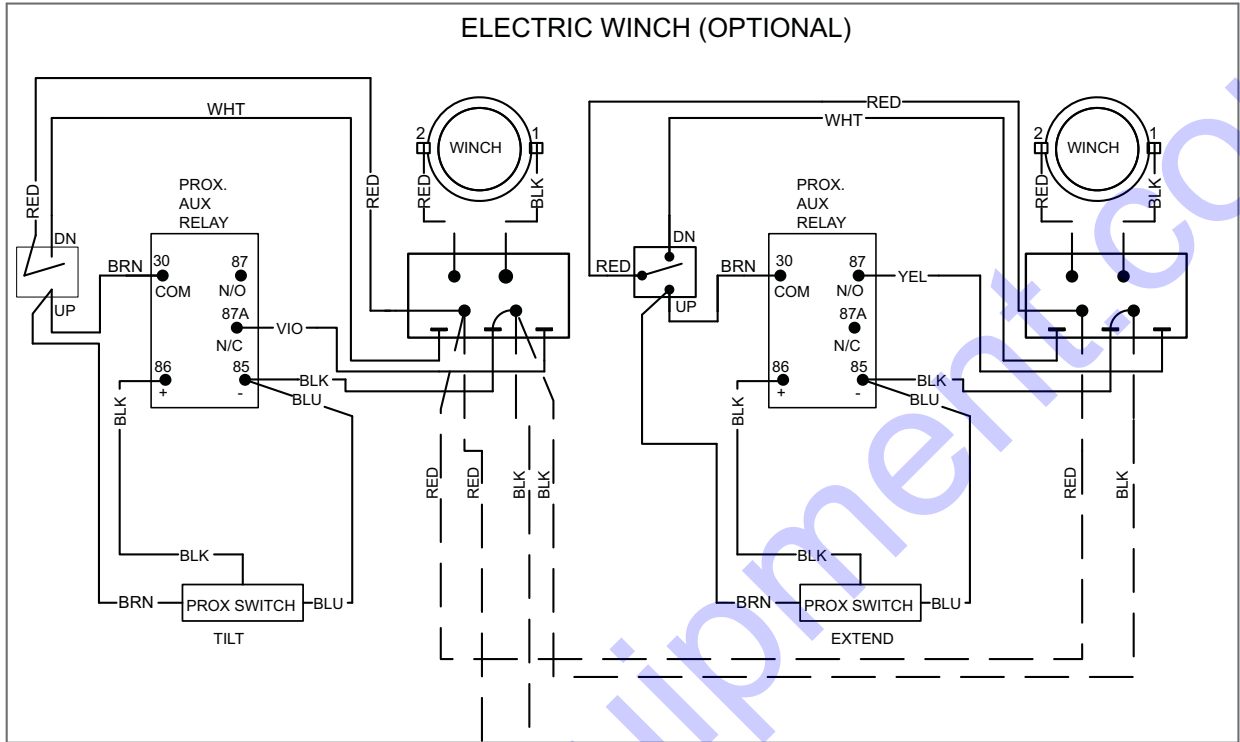

MAST JUNCTION BOX WIRING DIAGRAM

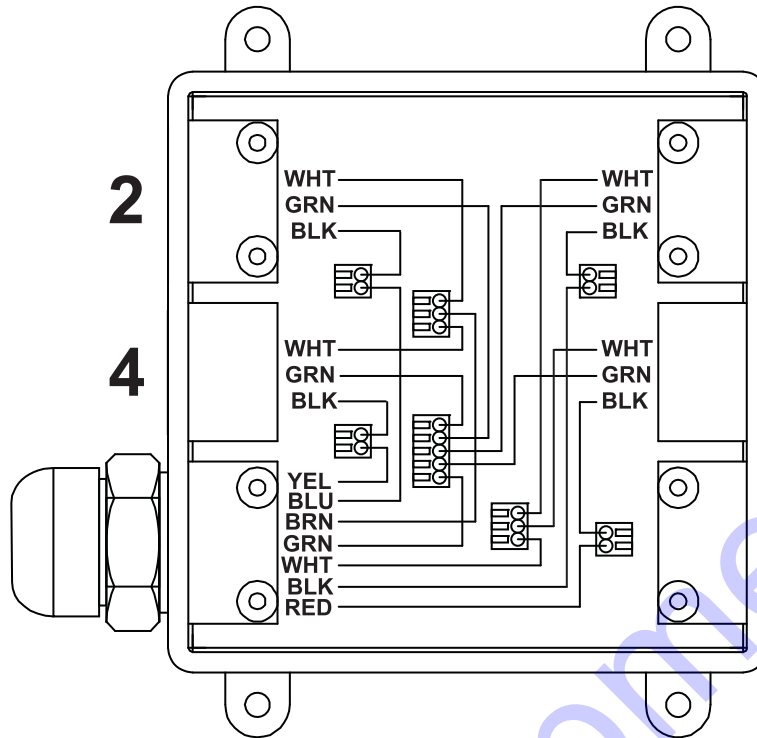

Discount Equipment

Discount-Equipment.com is your online resource for commercial and industrial quality parts and equipment sales.

Locations:

Florida (West Palm Beach): [561-964-4949](tel:561-964-4949)

Outside Florida TOLL FREE: [877-690-3101](tel:877-690-3101)

Need parts? Check out our website at www.discount-equipment.com

Can't find what you need?

Click on this link: <http://www.discount-equipment.com/category/5443-parts/> and fill out the request form.

Please have the machine model and serial number available in order to help us get you the correct parts. One of our experienced staff members will get back to you with a quote for the right part that your machine needs.

We sell worldwide for the brands: Genie, Terex, JLG, MultiQuip, Mayco, Toro/Stone, Diamond Products, Magnum, Airman, Mustang, Power Blanket, Nifty Lift, Atlas Copco, Chicago Pneumatic, Allmand Brothers, Essick, Miller Spreader, Skyjack, Lull, Skytrak, Tsurumi, Husquvarna/Target, Whiteman-Concrete/Mortar, Stow-Concrete/Mortar, Baldor, Wacker, Sakai, Snorkel, Upright, Mi-T-M, Sullair, Neal, Basic, Dynapac, MBW, Weber, Bartell, Bennar Newman, Haulotte, Ditch Runner, Blaw-Knox, Himoina, Best, Buddy, Crown, Edco, Wyco, Bomag, Laymor, Terremite, Barreto, EZ Trench, Takeuchi, Basic, Bil-Jax, Curtis, Gehl, Heli, Honda, ICS/PowerGrit, Puckett, Waldon, ASV, IHI, Partner, Imer, Clipper, MMD, Koshin, Rice, Gorman Rupp, CH&E, Cat Pumps, Comet, General Pump, Giant, AMida, Coleman, NAC, Gradall, Square Shooter, Kent, Stanley, Tamco, Toku, Hatz, Kohler, Robin, Wisconsin, Northrock, Oztec, Toker TK, Rol-Air, Small Line, Wanco, Yanmar

New Equipment - Used Equipment - Rental Equipment - Parts and Accessories

Discount Equipment

www.discount-equipment.com

561-964-4949

Sales: info@Discount-Equipment.com

Parts: wbparts@Discount-Equipment.com



www.discount-equipment.com

REV: B
PART NO: 13134
11.07.08