

OPERATION AND PARTS MANUAL



Mikasa SERIES
MODEL MTX70HDR
TAMPING RAMMER
(HONDA GXR120RT-KRBF GASOLINE ENGINE)

Revision # 0 (02/02/17)



www.discount-equipment.com

THIS MANUAL MUST ACCOMPANY THE EQUIPMENT AT ALL TIMES.

Discount Equipment

Discount-Equipment.com is your online resource for commercial and industrial quality parts and equipment sales.

Locations:

Florida (West Palm Beach): [561-964-4949](tel:561-964-4949)

Outside Florida TOLL FREE: [877-690-3101](tel:877-690-3101)

Need parts? Check out our website at www.discount-equipment.com

Can't find what you need?

Click on this link: <http://www.discount-equipment.com/category/5443-parts/> and fill out the request form.

Please have the machine model and serial number available in order to help us get you the correct parts. One of our experienced staff members will get back to you with a quote for the right part that your machine needs.

We sell worldwide for the brands: Genie, Terex, JLG, MultiQuip, Mayco, Toro/Stone, Diamond Products, Magnum, Airman, Mustang, Power Blanket, Nifty Lift, Atlas Copco, Chicago Pneumatic, Allmand Brothers, Essick, Miller Spreader, Skyjack, Lull, Skytrak, Tsurumi, Husquvarna/Target, Whiteman-Concrete/Mortar, Stow-Concrete/Mortar, Baldor, Wacker, Sakai, Snorkel, Upright, Mi-T-M, Sullair, Neal, Basic, Dynapac, MBW, Weber, Bartell, Bennar Newman, Haulotte, Ditch Runner, Blaw-Knox, Himoina, Best, Buddy, Crown, Edco, Wyco, Bomag, Laymor, Terremite, Barreto, EZ Trench, Takeuchi, Basic, Bil-Jax, Curtis, Gehl, Heli, Honda, ICS/PowerGrit, Puckett, Waldon, ASV, IHI, Partner, Imer, Clipper, MMD, Koshin, Rice, Gorman Rupp, CH&E, Cat Pumps, Comet, General Pump, Giant, AMida, Coleman, NAC, Gradall, Square Shooter, Kent, Stanley, Tamco, Toku, Hatz, Kohler, Robin, Wisconsin, Northrock, Oztec, Toker TK, Rol-Air, Small Line, Wanco, Yanmar

New Equipment - Used Equipment - Rental Equipment - Parts and Accessories

Discount Equipment

www.discount-equipment.com

561-964-4949

Sales: info@Discount-Equipment.com

Parts: wbparts@Discount-Equipment.com

PROPOSITION 65 WARNING



 WARNING 
CALIFORNIA — Proposition 65 Warning
Gasoline engine exhaust and some of its constituents are known to the State of California to cause cancer, birth defects and other reproductive harm.

TABLE OF CONTENTS

MTX70HDR Rammer

Proposition 65 Warning	2
Table Of Contents	4
Parts Ordering Procedures	5
Safety Information	6-9
Specifications	10
Noise And Vibration Emissions	11
General Information	12
Components	13
Basic Engine	14
Inspection	15
Operation	16-17
Maintenance	18
Troubleshooting	19-21
Explanation Of Code In Remarks Column	22
Suggested Spare Parts	23

Component Drawings

Nameplates And Decals Assembly	24-25
Crankcase And Engine Assembly	26-29
Guide Cylinder Assembly	30-31
Foot Assembly	32-33
Fuel Tank And Handle Assembly	34-35
Combination Lever Assembly	36-37
Tools Assembly	38-39

Honda GXR120RT-KRBF Engine

Cylinder Barrel Assembly	40-41
Crankcase Cover Assembly	42-43
Crankshaft Assembly	44-45
Piston And Connecting Rod Assembly	46-47
Camshaft Assembly	48-49
Recoil Starter Assembly	50-51
Fan Cover Assembly	52-53
Carburetor Assembly	54-55
Muffler Assembly	56-57
Flywheel Ignition Assembly	58-59
Control Assembly	60-61
Tools And Labels Assembly	62-63
Terms And Conditions Of Sale — Parts	64

NOTICE

Specifications and part numbers are subject to change without notice.

SAFETY INFORMATION

Do not operate or service the equipment before reading the entire manual. Safety precautions should be followed at all times when operating this equipment. Failure to read and understand the safety messages and operating instructions could result in injury to yourself and others.



SAFETY MESSAGES

The four safety messages shown below will inform you about potential hazards that could injure you or others. The safety messages specifically address the level of exposure to the operator and are preceded by one of four words: **DANGER**, **WARNING**, **CAUTION** or **NOTICE**.

SAFETY SYMBOLS

! DANGER

Indicates a hazardous situation which, if not avoided, **WILL** result in **DEATH** or **SERIOUS INJURY**.

! WARNING

Indicates a hazardous situation which, if not avoided, **COULD** result in **DEATH** or **SERIOUS INJURY**.

! CAUTION

Indicates a hazardous situation which, if not avoided, **COULD** result in **MINOR** or **MODERATE INJURY**.

NOTICE

Addresses practices not related to personal injury.

Potential hazards associated with the operation of this equipment will be referenced with hazard symbols which may appear throughout this manual in conjunction with safety messages.

Symbol	Safety Hazard
	Lethal exhaust gas hazards
	Explosive fuel hazards
	Burn hazards
	Respiratory hazards
	Accidental starting hazards
	Eye and hearing hazards

SAFETY INFORMATION

GENERAL SAFETY

CAUTION

- **NEVER** operate this equipment without proper protective clothing, shatterproof glasses, respiratory protection, hearing protection, steel-toed boots and other protective devices required by the job or city and state regulations.



- **NEVER** operate this equipment when not feeling well due to fatigue, illness or when under medication. 
- **NEVER** operate this equipment under the influence of drugs or alcohol.



- **ALWAYS** check the equipment for loosened threads or bolts before starting.
- **DO NOT** use the equipment for any purpose other than its intended purposes or applications.

NOTICE

- This equipment should only be operated by trained and qualified personnel 18 years of age and older.
- Whenever necessary, replace nameplate, operation and safety decals when they become difficult read.
- Manufacturer does not assume responsibility for any accident due to equipment modifications. Unauthorized equipment modification will void all warranties.
- **NEVER** use accessories or attachments that are not recommended by Multiquip for this equipment. Damage to the equipment and/or injury to user may result.
- **ALWAYS** know the location of the nearest fire extinguisher.
- **ALWAYS** know the location of the nearest first aid kit.



- **ALWAYS** know the location of the nearest phone or **keep a phone on the job site**. Also, know the phone numbers of the nearest **ambulance, doctor** and **fire department**. This information will be invaluable in the case of an emergency.

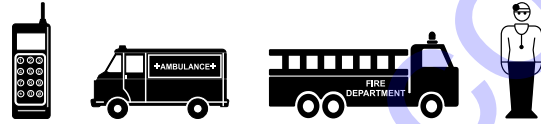

RAMMER SAFETY

DANGER

- **NEVER** operate the equipment in an explosive atmosphere or near combustible materials. An explosion or fire could result causing severe **bodily harm or even death**.



WARNING

- **NEVER** disconnect any **emergency or safety devices**. These devices are intended for operator safety. Disconnection of these devices can cause severe injury, bodily harm or even death. Disconnection of any of these devices will void all warranties.
- **DO NOT** use this machine on ground that is harder than the machine can handle, or for driving pilings or tamping rock beds. Furthermore, use of the machine on sloping ground, such as the side of an embankment, may make the machine unstable and can cause an accident. It can also result in premature machine wear due to uneven loads on the machine.

Use the machine with confidence for tamping earth and sand, soil, gravel, and asphalt. **DO NOT** use the machine for other types of jobs.

CAUTION

- **NEVER** lubricate components or attempt service on a running machine.

NOTICE

- **ALWAYS** keep the machine in proper running condition.
- Fix damage to machine and replace any broken parts immediately.
- **ALWAYS** store equipment properly when it is not being used. Equipment should be stored in a clean, dry location out of the reach of children and unauthorized personnel.

SAFETY INFORMATION

ENGINE SAFETY

DANGER

- The engine fuel exhaust gases contain poisonous carbon monoxide. This gas is colorless and odorless, and can cause death if inhaled.
- The engine of this equipment requires an adequate free flow of cooling air. **NEVER** operate this equipment in any enclosed or narrow area where free flow of the air is restricted. If the air flow is restricted it will cause injury to people and property and serious damage to the equipment or engine.



WARNING

- **DO NOT** place hands or fingers inside engine compartment when engine is running.
- **NEVER** operate the engine with heat shields or guards removed.
- **DO NOT** remove the engine oil drain plug while the engine is hot. Hot oil will gush out of the oil tank and severely scald any persons in the general area of the rammer.



CAUTION

- **NEVER** touch the hot exhaust manifold, muffler or cylinder. Allow these parts to cool before servicing equipment.



NOTICE

- **NEVER** run engine without an air filter or with a dirty air filter. Severe engine damage may occur. Service air filter frequently to prevent engine malfunction.
- **NEVER** tamper with the factory settings of the engine or engine governor. Damage to the engine or equipment can result if operating in speed ranges above the maximum allowable.



FUEL SAFETY

DANGER

- **DO NOT** add fuel to equipment if it is placed inside truck bed with plastic liner. Possibility exists of explosion or fire due to static electricity.

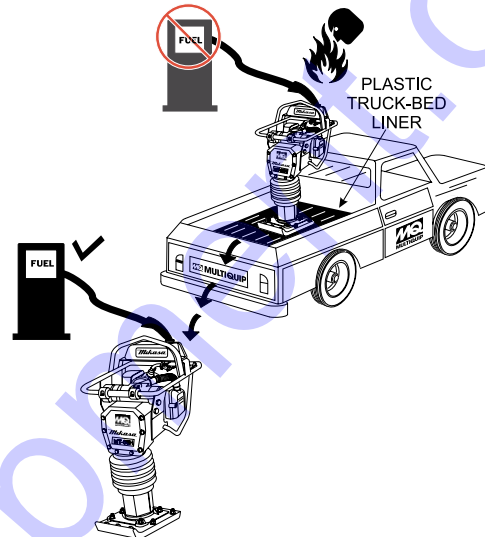

- **DO NOT** start the engine near spilled fuel or combustible fluids. Fuel is extremely flammable and its vapors can cause an explosion if ignited.
- **ALWAYS** refuel in a well-ventilated area, away from sparks and open flames.
- **ALWAYS** use extreme caution when working with **flammable** liquids.
- **DO NOT** fill the fuel tank while the engine is running or hot.
- **DO NOT** overfill tank, since spilled fuel could ignite if it comes into contact with hot engine parts or sparks from the ignition system.
- Store fuel in appropriate containers, in well-ventilated areas and away from sparks and flames.
- **NEVER** use fuel as a cleaning agent.
- **DO NOT** smoke around or near the equipment. Fire or explosion could result from fuel vapors or if fuel is spilled on a hot engine.



TRANSPORTING SAFETY

CAUTION

- NEVER allow any person or animal to stand underneath the equipment while lifting.

NOTICE

- Before lifting, make sure that the equipment parts (hook and vibration insulator) are not damaged and screws are not loose or missing.
- Always make sure crane or lifting device has been properly secured to the lifting bail (hook) of the equipment.
- **ALWAYS** shutdown engine before transporting.
- **NEVER** lift the equipment while the engine is running.
- Tighten fuel tank cap securely and close fuel cock to prevent fuel from spilling.
- Use adequate lifting cable (wire or rope) of sufficient strength.
- Use one point suspension hook and lift straight upwards.
- **DO NOT** lift machine to unnecessary heights.
- **ALWAYS** tie down equipment during transport by securing the equipment with rope.
- Never allow any person or animal to stand underneath the equipment while lifting.

ENVIRONMENTAL SAFETY

NOTICE

- Dispose of hazardous waste properly. Examples of potentially hazardous waste are used motor oil, fuel and fuel filters. 
- **DO NOT** use food or plastic containers to dispose of hazardous waste.
- **DO NOT** pour waste, oil or fuel directly onto the ground, down a drain or into any water source.

SPECIFICATIONS

Table 1. Rammer Specifications

Overall Height	40.43 in. (1027 mm)
Overall Width	13.78 in. (350 mm)
Over Length	31.02 in. (788 mm)
Shoe Size (W x L)	13.4 x 11.2 in. (340 x 285 mm)
Fuel Tank Capacity	2.7 qt. (2.5 liters)
Lubrication Oil Capacity	0.8 qt. (0.75 liter)
No. of Impacts Per Second	10.7 - 11.5
Impact Force	2,855 lbf (12.7 kN)
Impact Plate Stroke	2 - 3.15 in. (50 - 80 mm)
Operating Weight	165.34 lbs. (75 kg)

Table 2. Engine Specifications

Model	Honda GXR120RTKRBF Engine
Type	Air-Cooled 4 Stroke, Overhead camshaft, single cylinder gasoline engine
Piston Displacement	7.38 cu.in. (121 cc)
Max. Output	3.6 hp/3,600 rpm (2.7 KW)
Max. Governed Speed, No Load	3,800 - 4,100 rpm
Cooling System	Air-Cooled
Engine Oil Capacity	0.3 qt. (0.28 liters)
Fuel	Unleaded gasoline
Lubricant for Engine	Automobile Oil; Class SE or higher
Starting System	Recoil Starter
Spark Plug Type	NGK CR5HSB/DENSO V16 FSR-VB

NOISE AND VIBRATION EMISSIONS

Table 3. Noise and Vibration Emissions

Measured Sound Power Level in dB(A)	104
Guaranteed Sound Power Level in dB(A)	107
Guaranteed Sound Pressure Level at Operator Station in dB(A)	94
Hand-Arm Vibration in m/s ²	5.6

NOTES:

1. *Products are tested for sound pressure level in accordance with European Directives 2000/14/EC and 2005/88/EC, relating to Noise Emission in the Environment by equipment for use outdoors.*
2. *Products are tested for hand/arm vibration (HAV) level in accordance with European Directives 2002/44/EC and EN500-4 and ISO 5349-1:2001, ISO 5349-2:2001.*

GENERAL INFORMATION

The Multiquip MTX70HDR tamping rammer is a powerful compacting tool capable of applying a tremendous force in consecutive impacts to a soil surface. Its applications include soil compacting for road, embankments and reservoirs as well as backfilling for gas pipelines, water pipelines and cable installation work.

The impact force of the MTX70HDR levels and uniformly compacts voids between soil particles to increase dry density.

Circular motion is converted to create impact force. The MTX70HDR tamping rammer develops a powerful compacting force at the foot of the rammer. To maintain optimum performance, proper operation and service are essential.

The MTX70HDR is equipped with an air cooled, four-cycle gasoline engine. Transmission of the power takes place by increasing the engine speed to engage the centrifugal clutch.

The MTX70HDR uses an oil bath lubrication system. Always check the oil level through the oil level sight glass at the rear of the tamper foot.

Before starting the MTX70HDR Tamping Rammer identify and understand the function of the controls.

CAUTION



Before starting operation check the lifting handle to:

1. Make sure that there is no damage on the bolts.
2. Make sure that there is no crack or breakage on handle.
3. Make sure that there is no fissure on the surface. If there is any abnormality or damage, replace with new one.

For operation:

This handle is to be used to lift up the shoe part of the machine with the body laid down on the ground or truck bed.

1. Use proper lifting techniques to avoid back injury. This handle is for manual lifting only.
2. Do not use this handle as a rammer lift point. Use the lifting point on the top of the machine.
3. Do not move the rammer with the lifting handle and the front rollers more than 16 feet (5 meters).

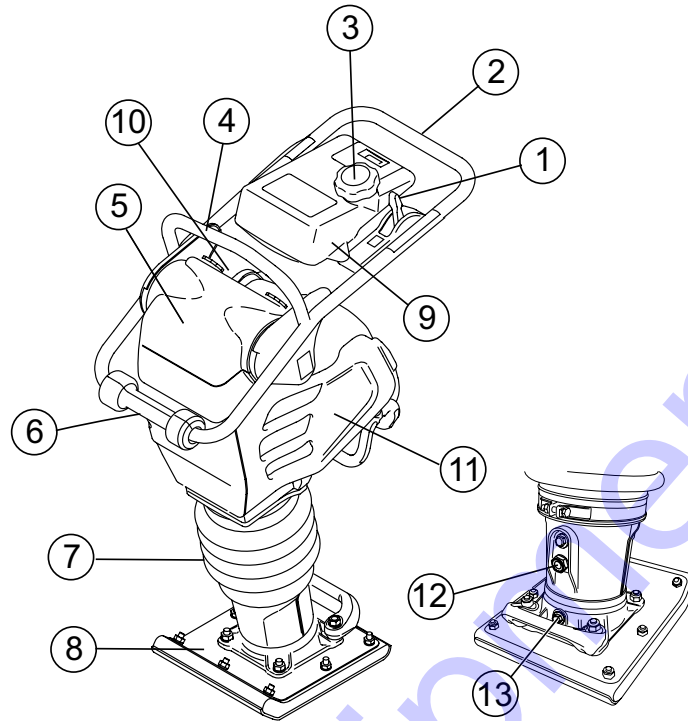

Figure 1. MTX70HDR Rammer

Figure 1 shows the location of the controls and components for the MTX70HDR Tamping Rammer. The functions of each control is described below:

1. **Combination (Throttle) Lever** — Used to adjust engine speed (rpm). Move lever forward (**SLOW**) to reduce engine speed, move lever back toward operator (**FAST**) to increase speed. Always operate the rammer at full speed (rpm).
2. **Handle** — To operate rammer, **GRIP** handle assembly firmly on both sides.
3. **Fuel Tank Cap** — Remove this cap to add unleaded gasoline to the fuel tank. Make sure cap is tightened securely. **DO NOT** over fill.
4. **Hook** — Used to lift rammer for transporting.
5. **Air Cleaner Cover** — Protects the air cleaner which prevents dirt and other debris from entering the engine.
6. **Roller** — Allows rammer to be moved around easily by rolling the unit.
7. **Bellows** — Reservoir for oil bath.
8. **Foot** — Laminated wood with tempered steel plate for superior shock absorption.
9. **Fuel Tank** — Holds the fuel for the unit (up to 3.2 quarts).
10. **Muffler** — Reduces the noise of the engine when running.
11. **Engine** — This unit uses a Honda GXR120RTKRB gasoline engine.
12. **Oil Gauge (Sight Glass)** — Indicates the level of oil in the oil bath reservoir.
13. **Drain Valve** — Open this valve to remove oil from the bellows.

WARNING



Adding fuel to the tank should be accomplished only when the engine is stopped and has had an opportunity to cool down. In the event of a fuel spill, **DO NOT** attempt to start the engine until the fuel residue has been completely wiped up, and the area surrounding the engine is dry.

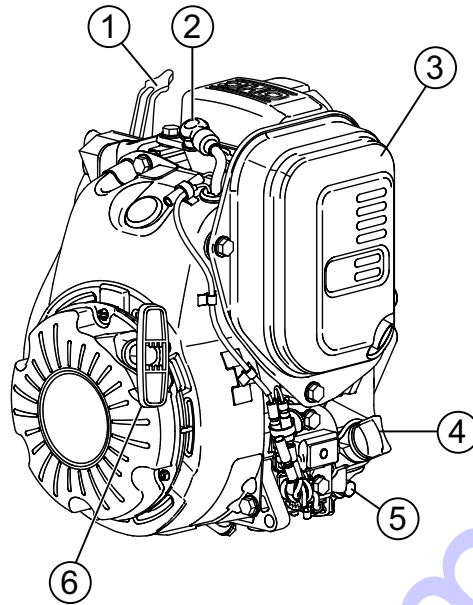

Figure 2. Honda GXR120RT-KRBF Engine

The engine (Figure 2) must be checked for proper lubrication and filled with fuel prior to operation. Refer to the engine manufacturer's manual for detailed operation and service information.

1. **Choke Lever** — Normally used in starting the engine in cold weather conditions. In cold weather, turn the choke lever to the fully closed position. In warm weather, set the choke lever halfway or completely open.
2. **Spark Plug** — Provides spark to the ignition system. Set spark plug gap to 0.024 - 0.028 inch (0.6 - 0.7 mm). Clean spark plug once a week.
3. **Muffler** — Used to reduce noise and emissions.
4. **Dipstick/Oil Filler Cap** — Remove this cap to determine if the engine oil is low. Add oil through this filler port as recommended in Table 3.
5. **Oil Drain Plug** — Remove this plug to remove oil from the engine's crankcase.

6. **Recoil Starter (pull rope)** — Manual-starting method. Pull the starter grip until resistance is felt, then pull briskly and smoothly.

NOTICE

Operating the engine without an air filter, with a damaged air filter, or a filter in need of replacement will allow dirt to enter the engine, causing rapid engine wear.

WARNING



Engine components can generate extreme heat. To prevent burns, **DO NOT** touch these areas while the engine is running or immediately after operating. **NEVER** operate the engine with the muffler removed.

It is extremely important that this section be read carefully before attempting to operate the rammer. **DO NOT** use your rammer until this section is thoroughly understood.

CRANKCASE AND SPRING CYLINDER OIL BATH

This unit uses an oil bath lubrication system. Perform the following:

1. Check the oil level through the oil level sight glass (Figure 3) at the rear of the tamper foot.

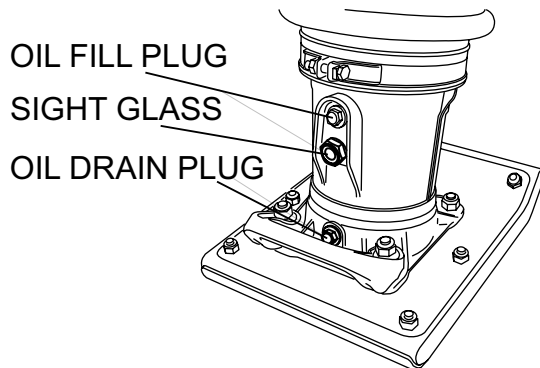

Figure 3. Foot Housing Sight Glass

NOTICE

The oil level should be kept at the half way point of the sight glass.

2. If oil is not visible, add 10W-30 SE, SF or higher grade motor oil into the oil fill plug opening (Figure 3). The bath contains approximately 0.8 qt. (0.75 liter).

ENGINE

1. Fill the fuel tank (Figure 4) with unleaded gasoline. At the same time, check the engine oil and make it a habit to replenish it often (Figure 5).

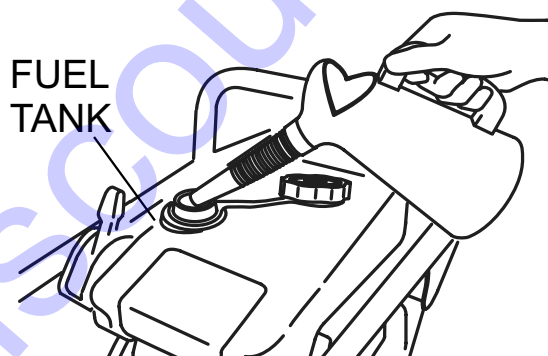

Figure 4. Fuel Tank

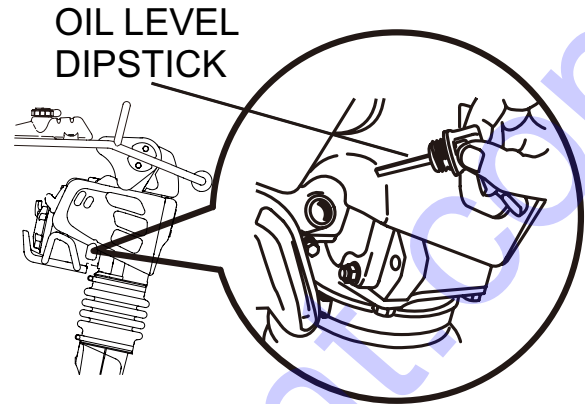

Figure 5. Engine Oil Dipstick

2. Low levels of oil may result in engine seizure due to high levels of consumption during operation.
3. Check the engine oil level and if the engine oil level is low, it should be refilled. Use the proper motor oil as suggested in the Table 4 below.

Table 4. Motor Oil Grade

Season or Temperature	Grade of motor oil (higher than MS class)
Spring, Summer or Autumn +120° F to +15° F	SAE 30
Winter +40° F to +15° F	SAE 30
Below +15° F	SAE 10W-30

GENERAL INSPECTION

1. Check all nuts, bolts fasteners for tightness. Retighten as necessary.
2. Clean any dirt from the recoil starter and foot pedestal. Wipe the entire unit clean before operating.
3. Replace any missing or damaged Safety Operation decals.
4. Adjust height of handle. Adjust handle by loosening nuts and moving handle to suit operation. Retighten nuts.

OPERATION

CAUTION

Failure to understand the operation of the Tamping Rammer could result in severe damage to the unit or personal injury.

INITIAL STARTUP

When starting the MTX70HDR Tamping Rammer perform the following:

1. Slide the throttle lever from the stop to the idle position (☛) (Figure 6). This opens the fuel cock and the engine electrical circuit is turned on automatically.



Figure 6. Throttle Lever (Idle Position)

2. Carburetor Purge System: Push the purge bulb four times or until you see fuel in the bulb (Figure 7).

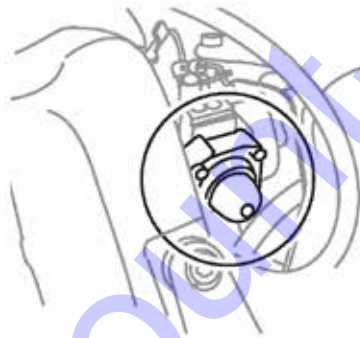

Figure 7. Purge Bulb

NOTICE

Pumping the purge bulb removes air from the fuel system. It does not pump fuel into the carburetor.

3. Place the choke lever to the closed position. When the weather is cold, close the choke all the way. When it is hot, or if the engine is hot, open the choke a little or leave it fully open.

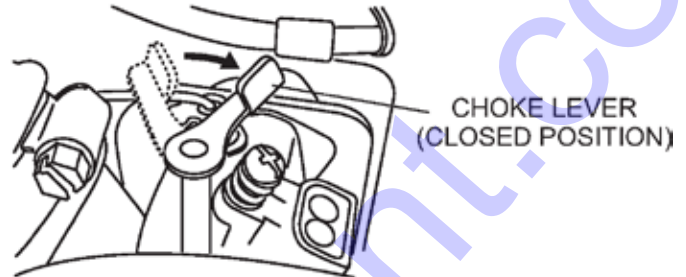

Figure 8. Choke Lever

4. Grip the starter rope handle (Figure 9) and pull it until you feel a slight resistance. Then pull sharply and quickly. Return the handle to the starter case before releasing.

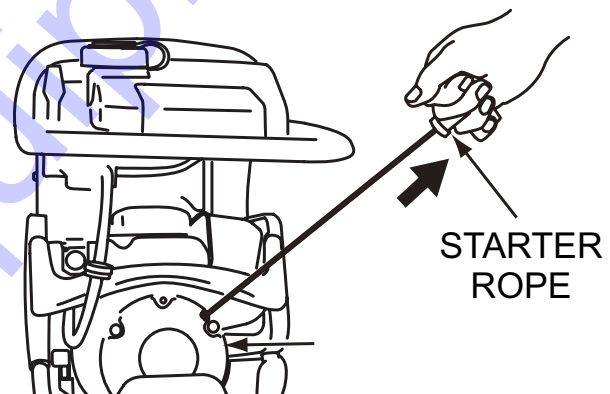

Figure 9. Recoil Starter

5. If engine fails to start, move the choke lever (Figure 8) to the half open position to avoid flooding.
6. Repeat steps 1 thru 5.
7. If the engine does not start after repeated attempts, check the spark plug for excess fuel. Clean and replace

the spark plug as needed.

OPERATION

1. To start the rammer tamping action, move the throttle lever (Figure 10) **quickly** from **IDLE** to the **START** (🔌) position. **DO NOT** move the throttle lever slowly as this may cause damage to the clutch or spring.

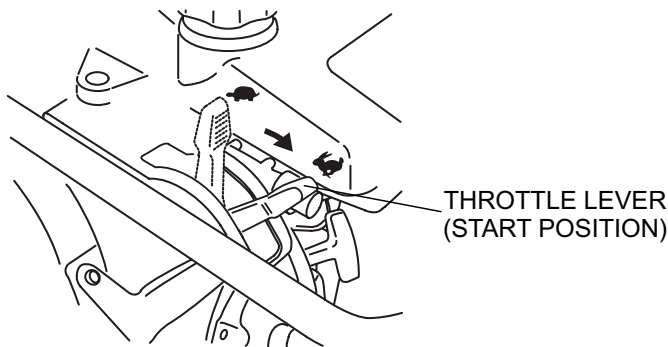

Figure 10. Throttle Lever (Start Position)

⚠ CAUTION

Make sure that the throttle lever is moved to the **FULL START** position. Operating the rammer at less than full speed can result in damage to the clutch springs or foot.

2. The MTX70HDR tamping rammer is designed to run at 3,800 to 4,100 rpm. At optimum rpm the foot hits at the rate between 590-695 impacts per minute. Increasing throttle speed past factory set rpm does not increase impacts and may damage unit. The MTX70HDR is designed to advance while tamping. For faster advance, pull back slightly on the handle so that rear of foot contacts soil first.

3. To stop the tamping action, move throttle lever quickly from **START** to **IDLE** position (Figure 6).

STOPPING THE ENGINE

1. Move throttle lever quickly from the **START** to **IDLE** position (Figure 6) and run the engine for three minutes at low speed. After the engine **cools**, move the throttle lever to the **STOP** position (Figure 11). The engine will stop and the fuel cock is automatically closed.

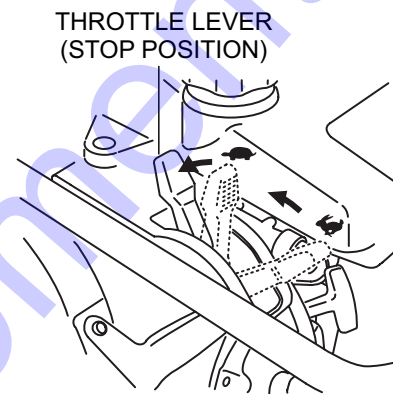

Figure 11. Throttle Lever (Stop Position)

2. If the engine does not stop due to a problem with the switch or the like, move the machine to a safe location and hold the throttle lever in the stop position. Let the machine run on idle and the machine will stop after a few minutes.

MAINTENANCE

DAILY

- Thoroughly remove dirt and oil from the engine and control area.
- Clean or replace the air cleaner elements as necessary. Check and retighten all fasteners as necessary.
- Check the spring box and bellows for oil leaks. Repair or replace as needed.

EVERY 50 HOURS

- Inspect in-line fuel filter (Figure 12) and replace if necessary.

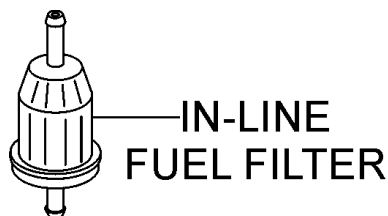

Figure 12. In-Line Fuel Filter

- Remove and clean the spark plug, then adjust the spark gap to 0.024~0.028 inch (0.6~0.7 mm).

EVERY 80 TO 100 HOURS

- Remove the air cleaner cover. Loosen and remove the 2 screws that hold the cover to the air cleaner assembly. If the primary element (Figure 13) is dirty, wash it with gasoline or kerosene. Then dip it in engine oil (SAE10W-30) and wring the element so that 25 to 30 cc of engine oil remains on the element.

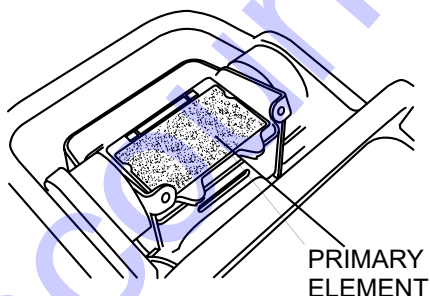

Figure 13. Air Cleaner Primary Element

EVERY 200 HOURS

- Remove the oil drain plug on foot housing (Figure 14) and drain the oil. Refill with approximately 0.8 qt. (0.75 liter) of 10W-30 SE, SF or higher grade motor oil. Oil should be midway in sight glass. Break-in oil should be changed after first 50 hours.

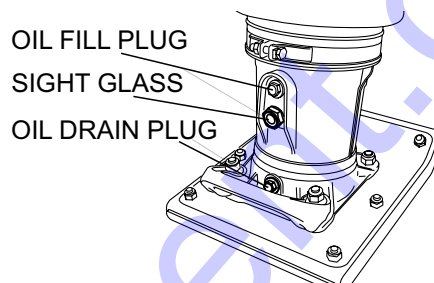

Figure 14. Oil Drain Plug

EVERY 6 MONTHS

- Clean the inside of the fuel tank with solvent.
- Inspect and clean fuel strainer (Figure 15). Replace strainer if necessary.

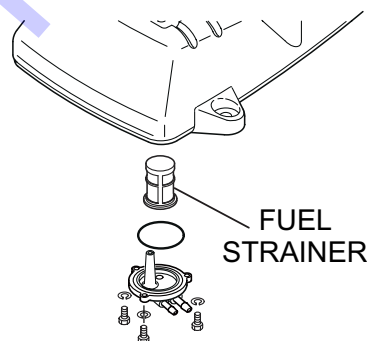

Figure 15. Fuel Strainer

EVERY 2 YEARS

- Replace the fuel line every 2 years even if there is no visible damage.

LONG TERM STORAGE

- Slide the throttle lever to the **STOP** position.
- Drain any fuel including in the fuel hose.
- Replace lubrication oil and apply grease to lubrication points.
- Cover the air intake on the air cleaner and the exhaust outlet on the muffler.
- Store unit indoors covered with plastic sheet in moisture free and dust free location out of direct sunlight.

TROUBLESHOOTING

Troubleshooting (Engine)		
Symptom	Possible Problem	Solution
Difficult to start, fuel is available, but no spark at spark plug.	Combo lever in incorrect position?	Make sure combo lever is in start position.
	Spark plug bridging?	Check gap, insulation or replace spark plug.
	Carbon deposit on spark plug?	Clean or replace spark plug.
	Short circuit due to deficient spark plug insulation?	Check spark plug insulation, replace if worn.
	Improper spark plug gap?	Set to proper gap.
	Fuel reaching carburetor?	Check fuel line.
	Water in fuel tank?	Flush or replace fuel tank.
	Fuel filter clogged?	Replace fuel filter.
	Stuck carburetor?	Check float mechanism.
	Spark plug is red?	Check transistor ignition unit.
	Spark plug is bluish white?	If insufficient compression, repair or replace engine. If injected air leaking, correct leak. If carburetor jets clogged, clean carburetor.
	No spark present at tip of spark plug?	Check transistor ignition unit is broken, and replace defective unit. Check if voltage cord cracked or broken and replace. Check if spark plug if fouled and replace.
No oil?	Add oil as required.	
Difficult to start, fuel is available, and spark is present at the spark plug.	ON/OFF switch is shorted?	Check switch wiring, replace switch.
	Ignition coil defective?	Replace ignition coil.
	Improper spark gap, points dirty?	Set correct spark gap and clean points.
	Condenser insulation worn or short circuiting?	Replace condenser.
	Spark plug wire broken or short circuiting?	Replace defective spark plug wiring.
Difficult to start, fuel is available, spark is present and compression is normal.	Wrong fuel type?	Flush fuel system, replace with correct type of fuel.
	Water or dust in fuel system?	Flush fuel system.
	Air cleaner dirty?	Clean or replace air cleaner.
	Choke open?	Close choke.
Difficult to start, fuel is available, spark is present and compression is low.	Suction/exhaust valve stuck or protruded?	Reseat valves.
	Piston ring and/or cylinder worn?	Replace piston rings and/or piston.
	Cylinder head and/or spark plug not tightened properly?	Torque cylinder head bolts and spark plug.
	Head gasket and/or spark plug gasket damaged?	Replace head and spark plug gaskets.
No fuel present at carburetor.	No fuel in fuel tank?	Fill with correct type of fuel.
	Fuel cock does not open properly?	Apply lubricant to loosen fuel cock lever, replace if necessary.
	Fuel filter/lines clogged?	Replace fuel filter.
	Fuel tank cap breather hole clogged?	Clean or replace fuel tank cap.
	Air in fuel line?	Bleed fuel line.

TROUBLESHOOTING

Troubleshooting (Engine) - continued		
Symptom	Possible Problem	Solution
Weak in power, compression is proper and does not misfire.	Air cleaner dirty?	Clean or replace air cleaner.
	Improper level in carburetor?	Check float adjustment, rebuild carburetor.
	Defective spark plug?	Clean or replace spark plug.
	Improper spark plug?	Set to proper gap.
Weak in power, compression is proper but misfires.	Water in fuel system?	Flush fuel system and replace with correct type of fuel.
	Dirty spark plug?	Clean or replace spark plug.
	Ignition coil defective?	Replace ignition coil.
Engine overheats.	Spark plug heat value incorrect?	Replace with correct type of spark plug.
	Wrong type of fuel?	Replace with correct type of fuel.
	Cooling fins dirty?	Clean cooling fins.
	Intake air restricted?	Clear intake of dirt and debris. Replace air cleaner elements as necessary.
	Oil level too low or too high?	Adjust oil to proper level.
Rotational speed fluctuates.	Governor adjusted incorrectly?	Adjust governor.
	Governor spring defective?	Replace governor spring.
	Fuel flow restricted?	Check entire fuel system for leaks or clogs.
Recoil starter malfunctions. (if applicable)	Recoil mechanism clogged with dust and dirt?	Clean recoil assembly with soap and water.
	Spiral spring loose?	Replace spiral spring.
Starter malfunctions.	Loose, damaged wiring?	Ensure tight, clean connections on battery and starter.
	Battery insufficiently charged?	Recharge or replace battery.
	Starter damaged or internally shorted?	Replace starter.
Burns too much fuel.	Over-accumulation of exhaust products?	Check and clean valves. Check muffler and replace if necessary.
	Wrong spark plug?	Replace spark plug with manufacturer's suggested type.
Exhaust color is continuously "white".	Lubricating oil is wrong viscosity?	Replace lubricating oil with correct viscosity.
	Worn rings?	Replace rings.
Exhaust color is continuously "black".	Air cleaner clogged?	Clean or replace air cleaner.
	Choke valve set to incorrect position?	Adjust choke valve to correct position.
	Carburetor defective, seal on carburetor broken?	Replace carburetor or seal.
	Poor carburetor adjustment, engine runs too rich?	Adjust carburetor.
Will not start, no power with key "ON". (if applicable)	ON/OFF device not activated ON?	Turn on ON/OFF device.
	Battery disconnected or discharged?	Check cable connections. Charge or replace battery.
	Ignition switch/wiring defective?	Replace ignition switch. Check wiring.

TROUBLESHOOTING

Troubleshooting (Rammer)		
Symptom	Possible Problem	Solution
Engine runs but rammer jumps erratically or not at all.	Operating speed of throttle lever is incorrectly set?	Set throttle lever to correct position.
	Oil in excess?	Drain excess oil. Bring to correct level.
	Clutch slips?	Replace or adjust clutch.
	Spring Failure?	Replace spiral spring.
	Speed of engine improper?	Adjust engine speed to correct operating RPM setting.
	Soil over-compacted?	Shut down machine and test soil.

EXPLANATION OF CODE IN REMARKS COLUMN

The following section explains the different symbols and remarks used in the Parts section of this manual. Use the help numbers found on the back page of the manual if there are any questions.

NOTICE

The contents and part numbers listed in the parts section are subject to change **without notice**. Multiquip does not guarantee the availability of the parts listed.

SAMPLE PARTS LIST

NO.	PART NO.	PART NAME	QTY.	REMARKS
1	12345	BOLT	1	INCLUDES ITEMS W/%
2%		WASHER, 1/4 IN.		NOT SOLD SEPARATELY
2%	12347	WASHER, 3/8 IN. ...	1	MQ-45T ONLY
3	12348	HOSE	A/R	MAKE LOCALLY
4	12349	BEARING	1	S/N 2345B AND ABOVE

NO. Column

Unique Symbols — All items with same unique symbol (@, #, +, %, or >) in the number column belong to the same assembly or kit, which is indicated by a note in the “Remarks” column.

Duplicate Item Numbers — Duplicate numbers indicate multiple part numbers, which are in effect for the same general item, such as different size saw blade guards in use or a part that has been updated on newer versions of the same machine.

NOTICE

When ordering a part that has more than one item number listed, check the remarks column for help in determining the proper part to order.

PART NO. Column

Numbers Used — Part numbers can be indicated by a number, a blank entry, or TBD.

TBD (To Be Determined) is generally used to show a part that has not been assigned a formal part number at the time of publication.

A blank entry generally indicates that the item is not sold separately or is not sold by Multiquip. Other entries will be clarified in the “Remarks” Column.

QTY. Column

Numbers Used — Item quantity can be indicated by a number, a blank entry, or A/R.

A/R (As Required) is generally used for hoses or other parts that are sold in bulk and cut to length.

A blank entry generally indicates that the item is not sold separately. Other entries will be clarified in the “Remarks” Column.

REMARKS Column

Some of the most common notes found in the “Remarks” Column are listed below. Other additional notes needed to describe the item can also be shown.

Assembly/Kit — All items on the parts list with the same unique symbol will be included when this item is purchased.

Indicated by:

“INCLUDES ITEMS W/(unique symbol)”

Serial Number Break — Used to list an effective serial number range where a particular part is used.

Indicated by:

“S/N XXXXX AND BELOW”

“S/N XXXX AND ABOVE”

“S/N XXXX TO S/N XXX”

Specific Model Number Use — Indicates that the part is used only with the specific model number or model number variant listed. It can also be used to show a part is NOT used on a specific model or model number variant.

Indicated by:

“XXXXX ONLY”

“NOT USED ON XXXX”

“Make/Obtain Locally” — Indicates that the part can be purchased at any hardware shop or made out of available items. Examples include battery cables, shims, and certain washers and nuts.

“Not Sold Separately” — Indicates that an item cannot be purchased as a separate item and is either part of an assembly/kit that can be purchased, or is not available for sale through Multiquip.

SUGGESTED SPARE PARTS

MTX70HDR TAMPING RAMMER WITH HONDA GXR120RT-KRBF ENGINE

1 to 3 units

Qty.	P/N	Description
1.....	956100062.....	THROTTLE WIRE
3.....	366010070.....	PRIMARY ELEMENT, AIR CLEANER
3.....	366010080.....	SECONDARY ELEMENT, AIR CLEANER
1.....	366350460.....	CAP ASSY., FUEL TANK
2.....	16910Z4ES21.....	FILTER, IN-LINE FUEL
3.....	9805655777.....	SPARK PLUG
1.....	954406010.....	STRAINER, FUEL TANK
1.....	28462Z0DV03.....	ROPE, RECOIL STARTER
1.....	956200110.....	COMBINATION LEVER
1.....	366900170.....	CUP AND PACKING SET
1.....	366348550.....	CLUTCH ASSY.

NOTICE

Part numbers on this Suggested Spare Parts list may supersede/replace the part numbers shown in the following parts lists.

NAMEPLATES AND DECALS ASSY.

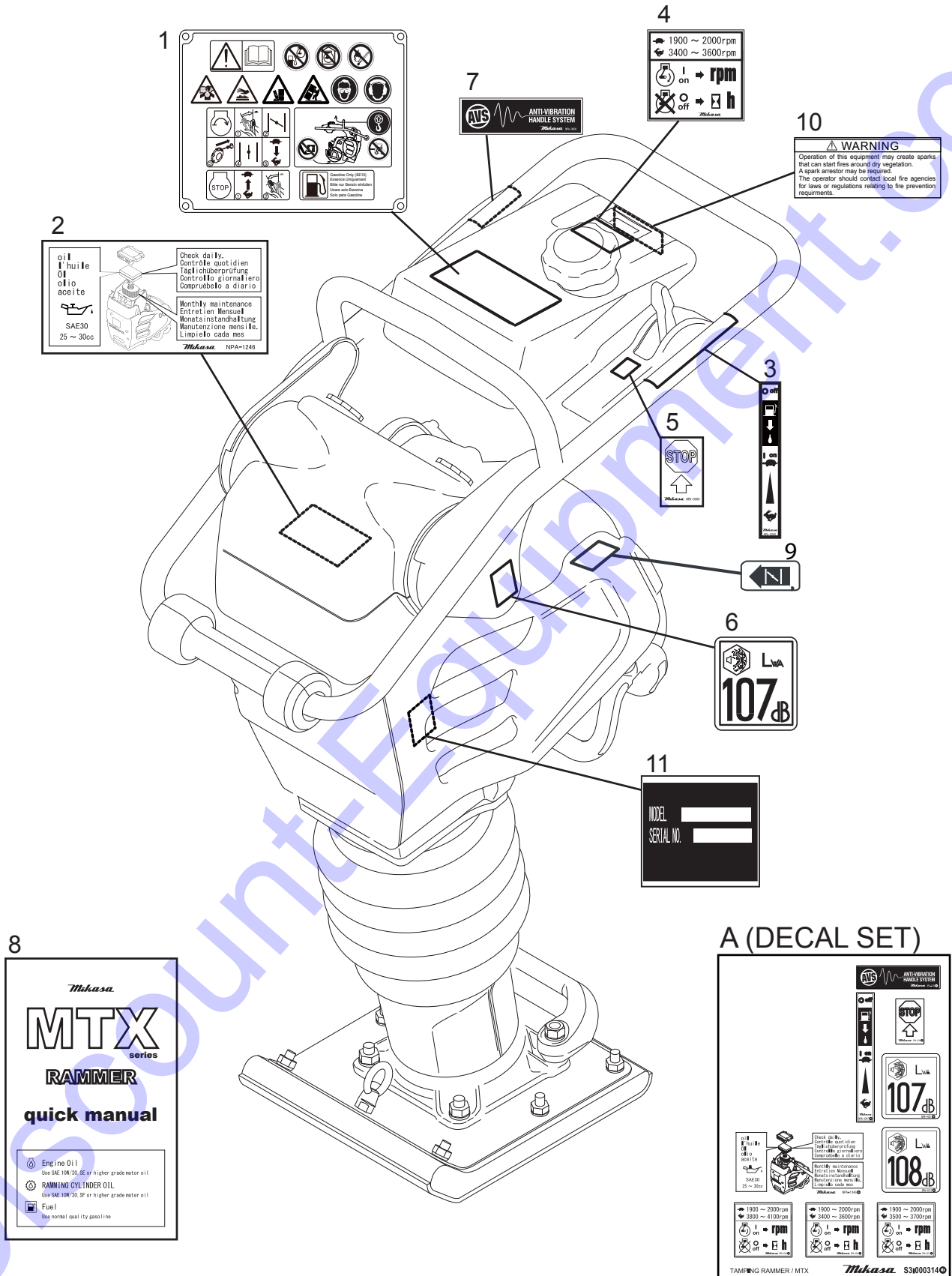

NAMEPLATES AND DECALS ASSY.

<u>NO.</u>	<u>PART NO.</u>	<u>PART NAME</u>	<u>QTY.</u>	<u>REMARKS</u>
1	920215440	OPERATION DECAL	1	
2#		DECAL, AIR CLEANER	1	
3#		DECAL, LEVER OPERATION	1	
4#		DECAL, MAX SPEED DECAL	1	
5#		DECAL, MACHINE STOP	1	
6#		DECAL, EC NOISE REQ. Lwa 107dB	1	
7#		DECAL, ANTI-VIB HANDLE	1	
8	920212540	QUICK MANUAL	1	
9	0732004430	DECAL, CHOKE OPERATION	1	
10	920214100	DECAL, E/G FIRE WARNING	1	
11		SERIAL PLATE NO.....	1	CONTACT MQ PARTS DEPT. W/ SERIAL NO.
A	920900040	DECAL SET.....	1	INCLUDES ITEMS W/#

CRANKCASE AND ENGINE ASSY

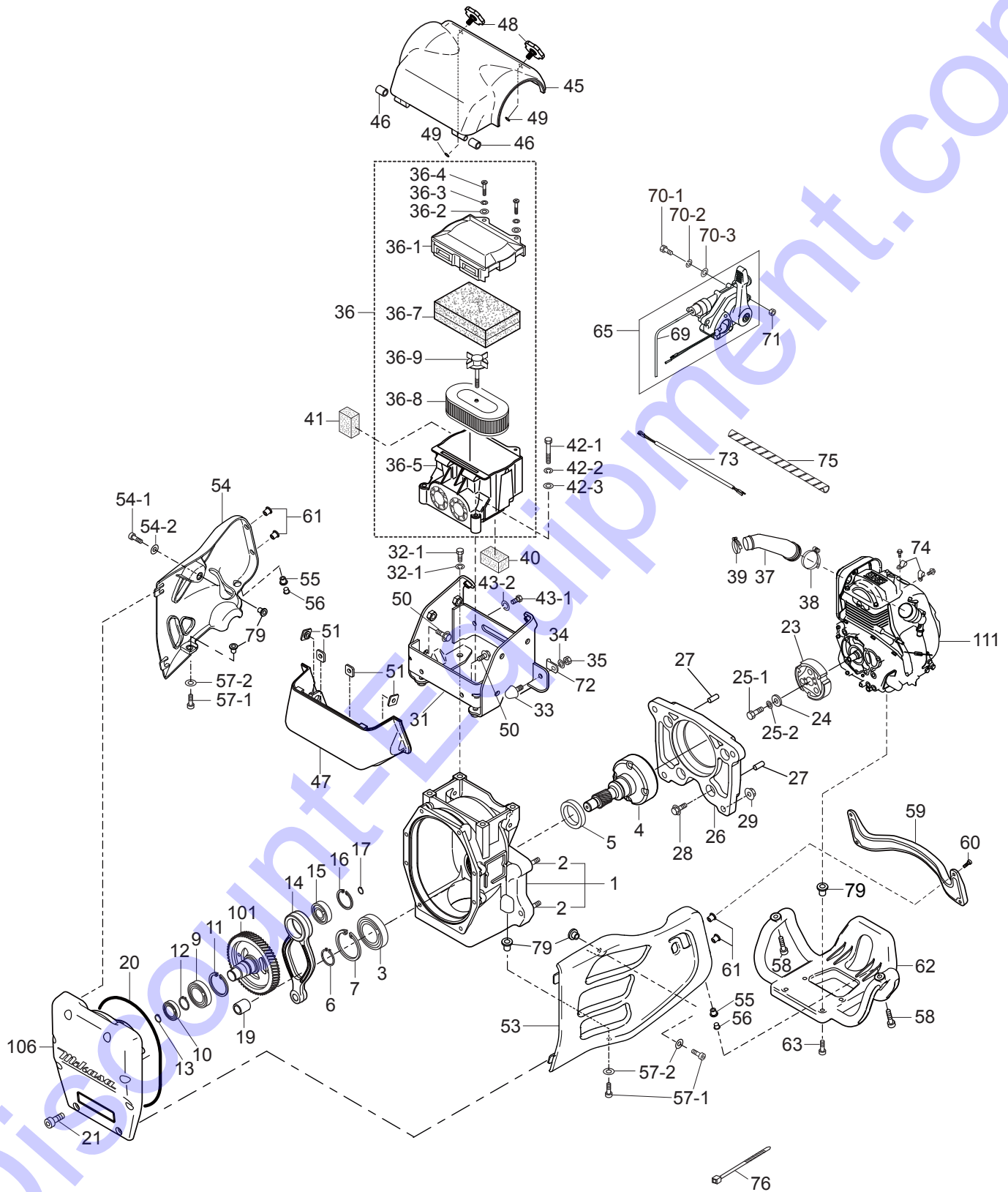

CRANKCASE AND ENGINE ASSY

<u>NO.</u>	<u>PART NO.</u>	<u>PART NAME</u>	<u>QTY.</u>	<u>REMARKS</u>
1	366910010	CRANKCASE	1	INCLUDES ITEMS W/\$
2\$	009120204	STUD BOLT, 10X30	4	
3	041006007	BEARING 6007Z	1	
4	366345170	DRUM, PINION	1	
5	060404010	OIL SEAL	1	
6	080200350	STOP RING	1	
7	080100620	STOP RING	1	
9	040006207	BEARING 6207	1	
10	040006305	BEARING 6305	1	
11	080100720	STOP RING	1	
12	080200350	STOP RING	1	
13	080200250	STOP RING	1	
14	366345230	CONNECTING ROD	1	
15	040006304	BEARING 6304	1	
16	080100520	STOP RING	1	
17	080200200	STOP RING	1	
19	047940060	NEEDLE BEARING	1	
20	050710080	O-RING	1	
21	001520825	SOCKET HEAD BOLT 8X25	8	
23	366348550	CLUTCH ASSY.	1	
24	952401450	WASHER, 5X22X3	1	
25-1	001220825	BOLT 8X25	1	
25-2	030208200	WASHER, LOCK M8	1	
26	366217180	FLANGE, ENGINE	1	
27	9430306100	KNOCK PIN	2	
28	001710830	FLANGE, BOLT 8X30	4	
29	022611010	FLANGE, NUT M10	4	
31	366346280	BRACKET, SHOCK ABSORBER	1	
32-1	001221030	BOLT, 10X30	4	
32-2	030210250	WASHER, LOCK M10	4	
33	939010270	STOPPER RUBBER	1	
34	030208200	WASHER, LOCK M8	1	
35	020308060	NUT M8	1	
36	366900010	AIR CLEANER COMPLETE	1	INCLUDES ITEMS W/#
36-1#	366010010	AIR CLEANER COVER COMPLETE	1	
36-2#	366010020	WASHER, FLAT M6	2	
36-3#	030206150	WASHER, LOCK M6	2	
36-4#	366010040	COIN BOLT M6	2	
36-5#	366010050	BASE COMPLETE, AIR CLEANER	1	
36-7#	366010070	PRIMARY ELEMENT COMPLETE	1	
36-8#	366010080	SECONDARY ELEMENT	1	
36-9#	362030040	GRIP BELT COMPLETE	1	
37	366345470	PIPE, INTAKE	1	
38	954407681	CYCLONE CLAMP	1	
39	954407682	CYCLONE CLAMP	1	
40	366460160	SEALING FORM, UNDER	1	
41	366460150	SEALING FORM, SIDE	1	

CRANKCASE AND ENGINE ASSY

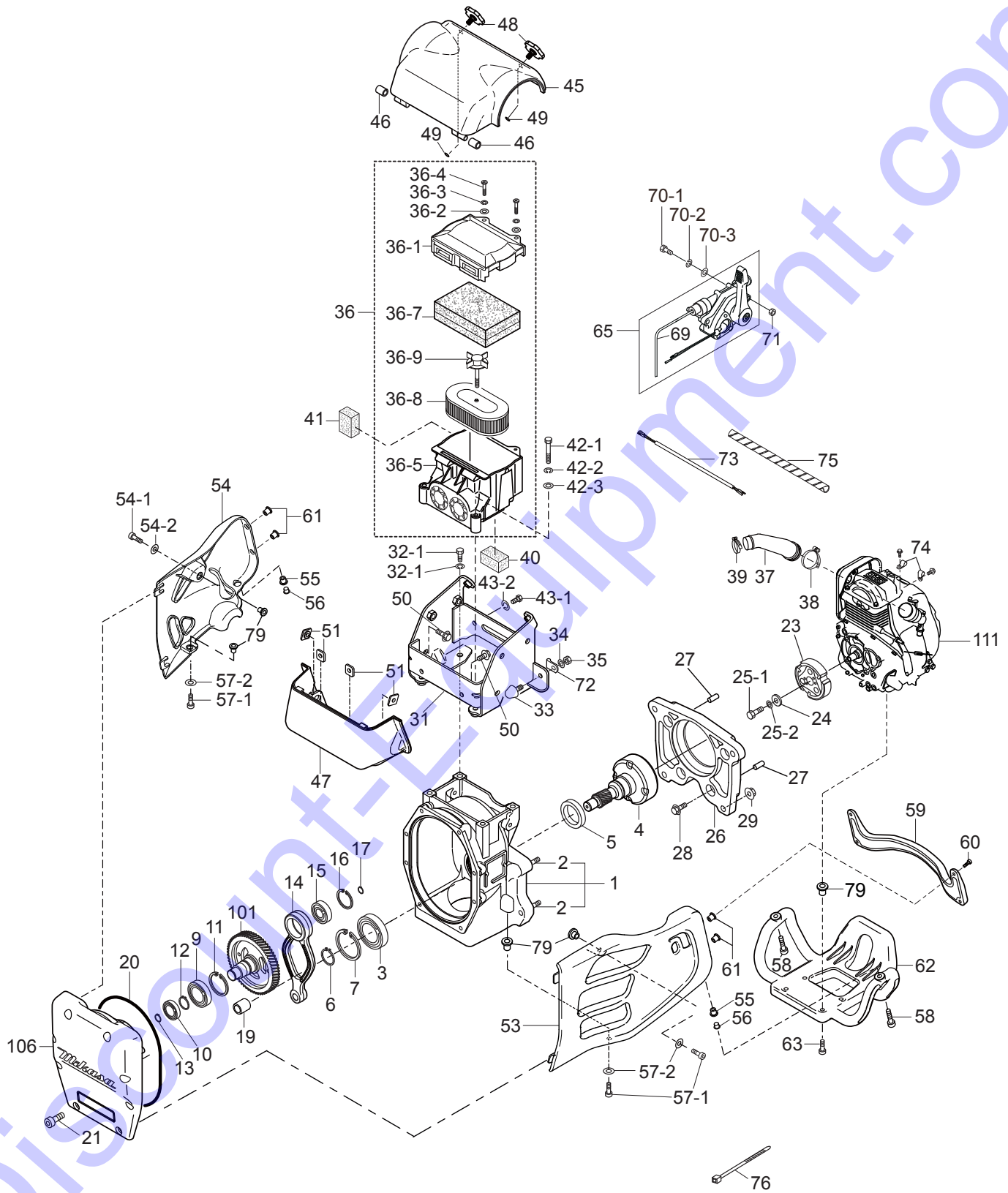

CRANKCASE AND ENGINE ASSY

<u>NO.</u>	<u>PART NO.</u>	<u>PART NAME</u>	<u>QTY.</u>	<u>REMARKS</u>
42-1	001220851	BOLT, 8X55	2	
42-2	030208200	WASHER, LOCK M8	2	
42-3	031108160	WASHER, FLAT M8	2	
43-1	001210815	BOLT, 8X15	2	
43-2	030208200	WASHER, LOCK M8	2	
45	366217340	COVER, CLEANER (UPPER)	1	
46	366460140	RUBBER BUSH	2	
47	366217350	COVER, CLEANER (LOWER)	1	
48	366345980	KNOB, CLEANER COVER	2	
49	050200060	O-RING	2	
50	009110040	FLANGE BOLT, 8X20	4	
51	959407670	SQUARE NUT M8	4	
53	366118893	GUARD, LINK	1	
54	366118903	GUARD, MUFFLER	1	
55	022910260	WELL NUT, M8	2	
56	366460170	FLANGE COLLAR 8	2	
57-1	001520820	SOCKET HEAD BOLT 8X20	4	
57-2	033910220	WASHER, FLAT M8	4	
58	009110038	SOCKET HEAD BOLT 8X30	2	
59	366217360	EX BAR	1	
60	009110039	SOCKET HEAD BOLT 6X25	4	
61	022910250	WELL NUT M6	4	
62	366118913	GUARD, ENGINE	1	
63	009110038	SOCKET HEAD BOLT 8X30	4	
65	356200100	COMBINATION LEVER ASSY. W/WIRE.....	1	INCLUDES ITEMS W/@
69@	956100062	THROTTLE WIRE	1	
70-1	001220620	BOLT, 6X20	2	
70-2	030206150	WASHER, LOCK M6	2	
70-3	031106100	WASHER, FLAT M6	2	
71	020306050	NUT M6	2	
72	959006120	CLIP	1	
73	366460110	WIRE HARNESS	1	
74	2067550101	CLAMP	2	
75	959021814	SPIRAL TUBE	1	
76	454010020	CLAMP	3	
79	366461050	COLLAR, GUARD	8	
101	366345190	CRANK, GEAR	1	
106	366010111	FRONT COVER	1	
111	912212101	ENGINE ASSY, GXR120RTKRBF	1	REPLACES P/N 912213001

GUIDE CYLINDER AND SPRING ASSY

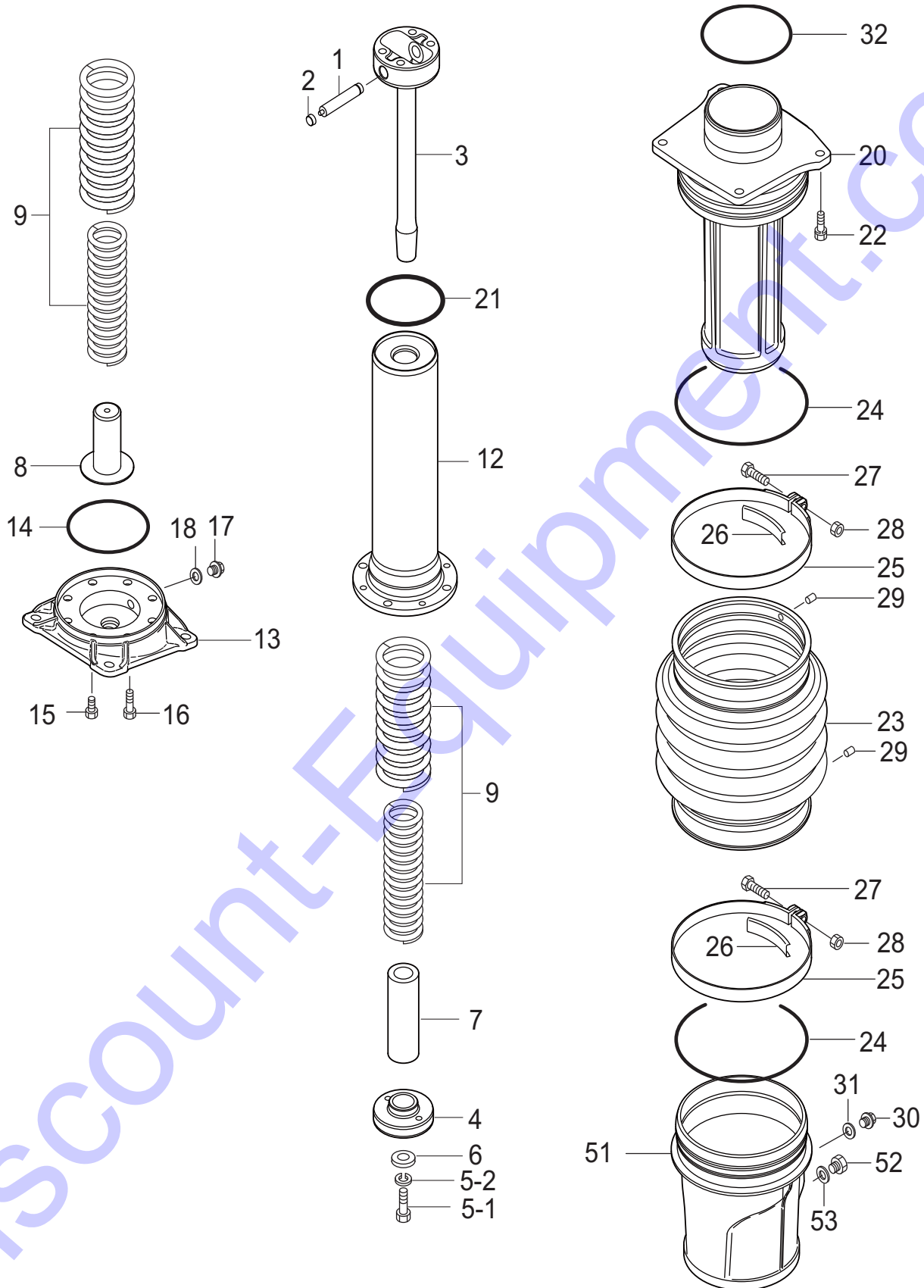

GUIDE CYLINDER AND SPRING ASSY

<u>NO.</u>	<u>PART NO.</u>	<u>PART NAME</u>	<u>QTY.</u>	<u>REMARKS</u>
1	366460100	PISTON PIN	1	
2	366459910	PLUG, PISTON PIN	2	
3	366346000	PISTON ROD	1	
4	371459690	PISTON END	1	
5-1	001221230	BOLT, 12X30	1	
5-2	030212300	WASHER, LOCK M12	1	
6	952404790	WASHER	1	
7	355447260	STOPPER, LOWER	1	
8	366459900	STOPPER, BOTTOM	1	
9	366459730	MAIN SPRING	2	
12	366345990	SPRING CYLINDER	1	
13	366217210	FOOT PLATE 12	1	
14	050100900	O-RING	1	
15	001521020	SOCKET HEAD BOLT, 10X20	4	
16	001521040	SOCKET HEAD BOLT, 10X40	4	
17	953405270	PLUG	1	
18	953405260	PACKING	1	
20	366217440	GUIDE CYLINDER	1	
21	050710070	O-RING	1	
22	002211035	BOLT 10X35 H, SW	4	
23	354010010	BELLOWS, ORANGE	1	
24	050931500	O-RING	2	
25	354336352	BELLOWS CLAMP	2	
26	354442340	BAND GUIDE, BELLOWS	2	
27	001220840	BOLT 8X40	2	
28	020308060	NUT M8	2	
29	354446170	PIN	2	
30	953405270	PLUG	1	
31	953405260	PACKING	1	
32	050200950	O-RING	1	
51	366118590	PROTECTION SLEEVE	1	
52	366460300	OIL GAUGE ASSY.	1	
53	953404670	COPPER PACKING	1	

FOOT ASSY

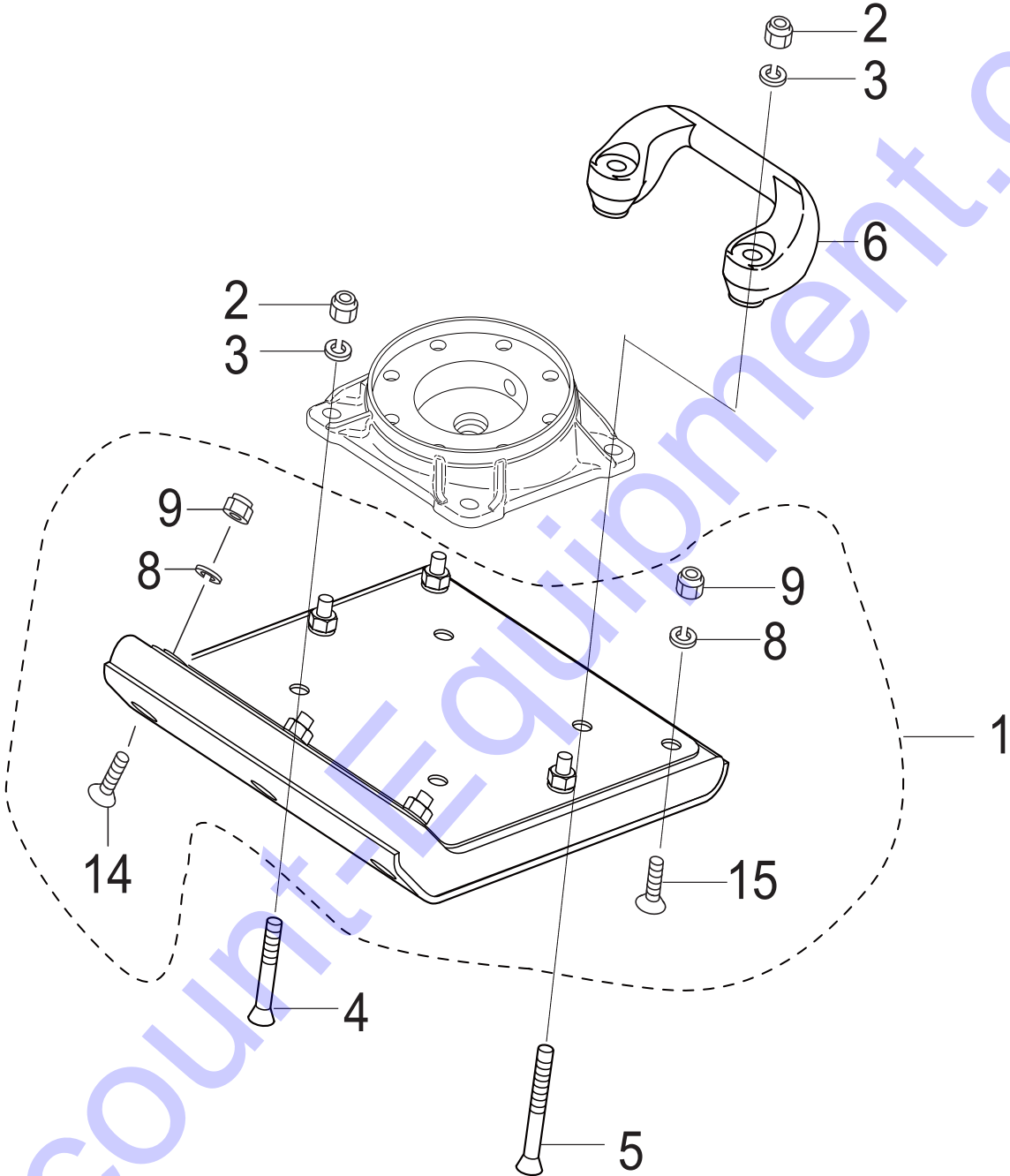

FOOT ASSY

<u>NO.</u>	<u>PART NO.</u>	<u>PART NAME</u>	<u>QTY.</u>	<u>REMARKS</u>
1	8511S	FOOT ASSY. 285	1.....	INCLUDES ITEMS W/# REPLACES P/N 366910020
2	021112140	NYLON NUT M12	4.....	REPLACES P/N 022711214
3	030212300	WASHER, LOCK M12	4	
4	009110034	BOLT, SQUARE NECK 12X65	2	
5	009110035	BOLT, SQUARE NECK 12X95	2	
6	363343390	GRIP HANDLEBAR	1	
8#	030210250	WASHER, LOCK M10	7	
9#	022711012	NYLON NUT M10	7	
14#	009110036	BOLT, SQUARE NECK 10X55	3	
15#	009110033	BOLT, SQUARE NECK 10X50	4	

FUEL TANK AND HANDLE ASSY

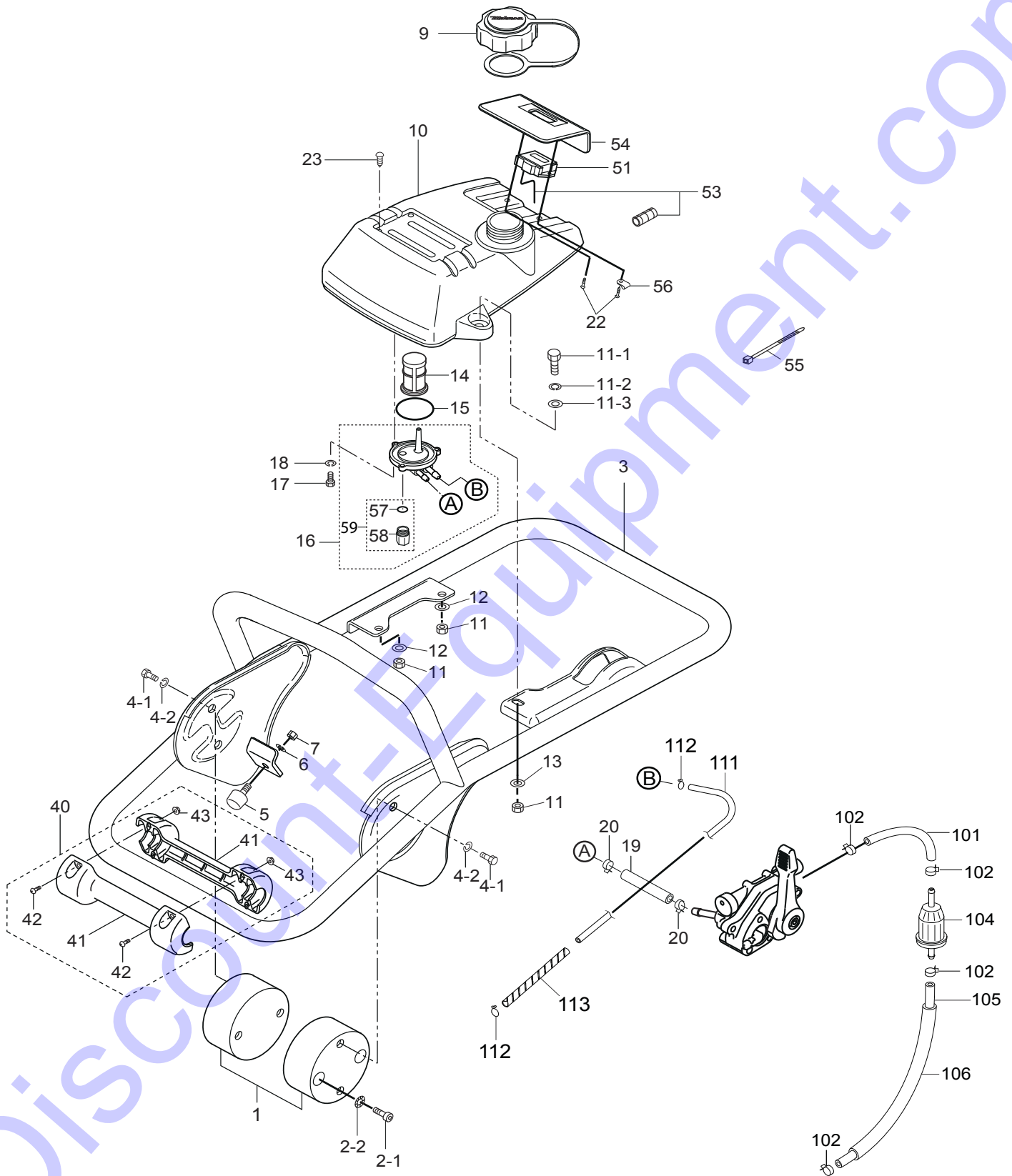

FUEL TANK AND HANDLE ASSY

<u>NO.</u>	<u>PART NO.</u>	<u>PART NAME</u>	<u>QTY.</u>	<u>REMARKS</u>
1	366346270	SHOCK ABSORBER W/PIN	2	
2-1	001521020	SOCKET HEAD BOLT 10X20	4	
2-2	033121009	TOOTHED LOCK WASHER B M10	4	
3	366119042	HANDLE/MTX	1	
4-1	001211020	BOLT 10X20	4	
4-2	030210250	WASHER, LOCK M10	4	
5	939010270	STOPPER RUBBER	1	
6	030208200	WASHER, LOCK M8	1	
7	020308060	NUT M8	1	
9	366350460	CAP ASSY., FUEL TANK	1	
10	366910042	FUEL TANK/MTX70	1	REPLACES P/N 366120250
11	022710809	NYLON NUT M8	3	
11-1	001210825	BOLT 8X25	3	
11-2	030208200	WASHER, LOCK M8	3	
11-3	031108160	WASHER, FLAT M8	3	
12	952401450	WASHER, 8.5X22X3	2	
13	031108160	WASHER, FLAT M8	1	
14	954406010	STRAINER	1	
15	050250420	O-RING	1	
16	366350580	HOLDER, FILTER	1	INCLUDES ITEMS W/\$
17	001200515	BOLT 5X15	3	
18	030205130	WASHER, LOCK M5	3	
19	959328406	FUEL HOSE	1	
20	954406420	HOSE BAND	2	
22	009110037	TAPPING SCREW, 5X20	2	
23	094010053	PAN HEAD SCREW, 4X8	4	
40	366910030	ROLLER ASSY. W/SCREW	1	INCLUDES ITEMS W/#
41#	366217170	ROLLER	2	
42#	091005020	SCREW, 5X20	4	
43#	022610505	FLANGE NUT M5	4	
51	955010311	TP22 TACHO/HOUR METER	1	
53	955010305	CURL CORD	1	
54	366345620	FINISHER, METER	1	
55	454010020	CLAMP	5	
56	954010270	CLIP	1	
57\$&	366464260	CUP, HOLDER FILTER	1	
58\$&	366464270	PACKING, HOLDER FILTER	1	
59\$	366900170	CUP AND PACKING SET	1	INCLUDES ITEMS W/&
101	959026404	FUEL HOSE	1	
102	H950024085008	CLAMP, TUBE	4	REPLACES P/N 954407060
104	16910Z4ES21	FILTER, IN-LINE FUEL	1	
105	959026103	FUEL HOSE	1	REPLACES P/N 959026401
106	950033600110M	TUBE, VINYL	1	REPLACES P/N 950033606020
111	959028301	RETURN HOSE	1	
112	954408170	HOSE CLIP	2	
113	959021814	SPIRAL TUBE	1	

COMBINATION LEVER ASSY

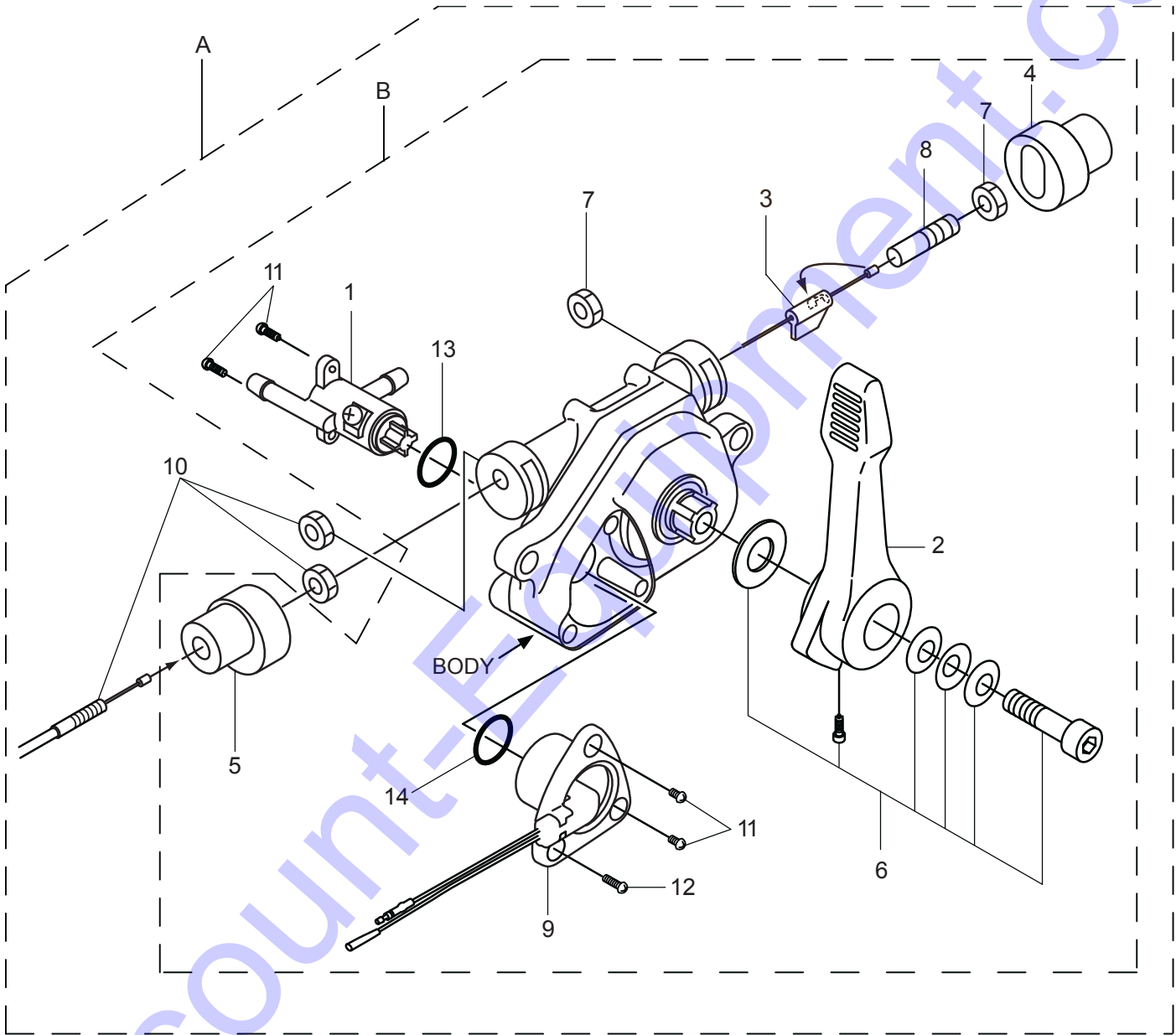

COMBINATION LEVER ASSY

<u>NO.</u>	<u>PART NO.</u>	<u>PART NAME</u>	<u>QTY.</u>	<u>REMARKS</u>
A	366900032	COMB. LEVER W/THROTTLE WIRE	1.....	INCLUDES ITEMS W/@
B@	956200110	COMB. LEVER W/OUT THROTTLE WIRE.....	1.....	INCLUDES ITEMS W/#
1@#	366349430	FUEL COCK	1	
2@#	366010310	LEVER	1	
3@#	366010190	SLIDER	1	
4@#	366010200	END CAP	1	
5@#	366010210	WIRE CAP	1	
6@#	366010220	BOLT AND WASHER SET	1	
7@#	020408050	NUT M8	2	
8@#	959407650	SOCKET HD. SCREW/THROTTLE WIRE	1	
9@#	366010320	STOP SWITCH	1	
10@	956100062	THROTTLE WIRE	1	
11@#	094010051	TAPPING SCREW B1 4X12	4	
12@#	094010052	TAPPING SCREW B1 4X30	1	
13@#	050200150	O-RING	1	
14@#	050200110	O-RING	1	

TOOLS ASSY.

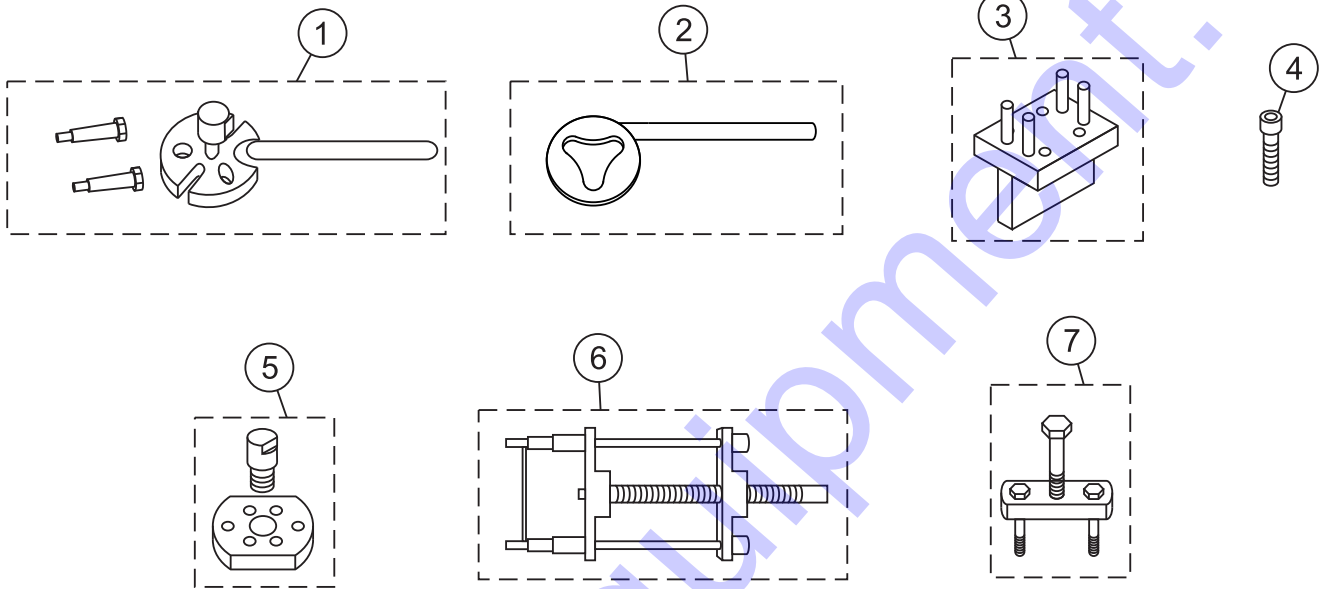

TOOLS ASSY.

<u>NO.</u>	<u>PART NO.</u>	<u>PART NAME</u>	<u>QTY.</u>	<u>REMARKS</u>
1	981010400	CLUTCH PULLER A	1	
2	983010060	CLUTCH MOUNTER	1	
3	983910030	PISTON ROD HOLDER	1	
4	009110044	SOCKET HD. BOLT 8X50 (FULL THREAD)	2	
		CRANK GEAR REMOVER		
5	983910021	CLUTCH PULLER B	1	
6	983010042	SPRING CYLINDER REMOVER	1	
7	983910010	PISTON END REMOVER	1	

HONDA GXR120RTKRB ENG. — CYLINDER BARREL ASSY.

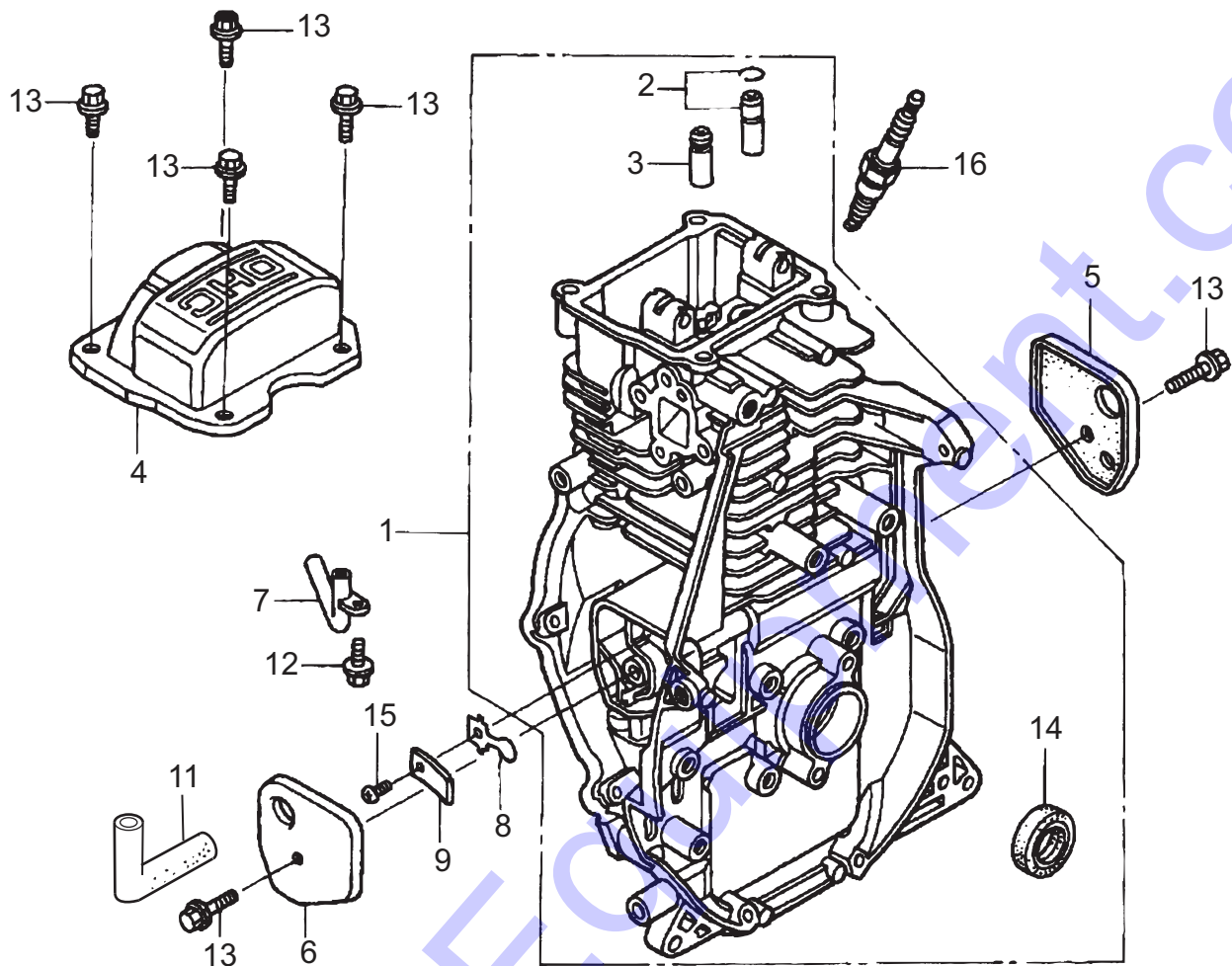

HONDA GXR120RTKRF ENG. — CYLINDER BARREL ASSY.

NO.	PART NO.	PART NAME	QTY.	REMARKS
1	12000ZDJ305	BARREL ASSY., CYLINDER	1.....	INCLUDES ITEMS W/\$
2\$	12201Z0D305	GUIDE ASSY., EX. VALVE (O.S.)	1	
3\$	12204Z0D305	GUIDE, INLET VALVE (O.S.)	1	
4	12311Z0D000	COVER, HEAD	1	
5	12355Z0D000	COVER COMP. A, BREATHER	1	
6	12365Z0D000	COVER COMP. B, BREATHER	1	
7	15171Z0DV00	PIPE, BREATHER	1	
8	15571Z0DV71	VALVE, OIL OUTLET	1	
9	15572ZM7000	PLATE, STOPPER	1	
11	15721Z0DV70	TUBE, BREATHER	1	
12	90008ZM7000	BOLT, 4X10	1	
13	90014952000	BOLT, FLANGE, 6X14	6	
14\$	91202ZE6013	OIL SEAL, 22X35X6	1	
15	93500030050A	SCREW, PAN, 3X5	1	
16	9805655777	PLUG, SPARK	1	

HONDA GXR120RTKRBFB ENG. — CRANKCASE COVER ASSY.

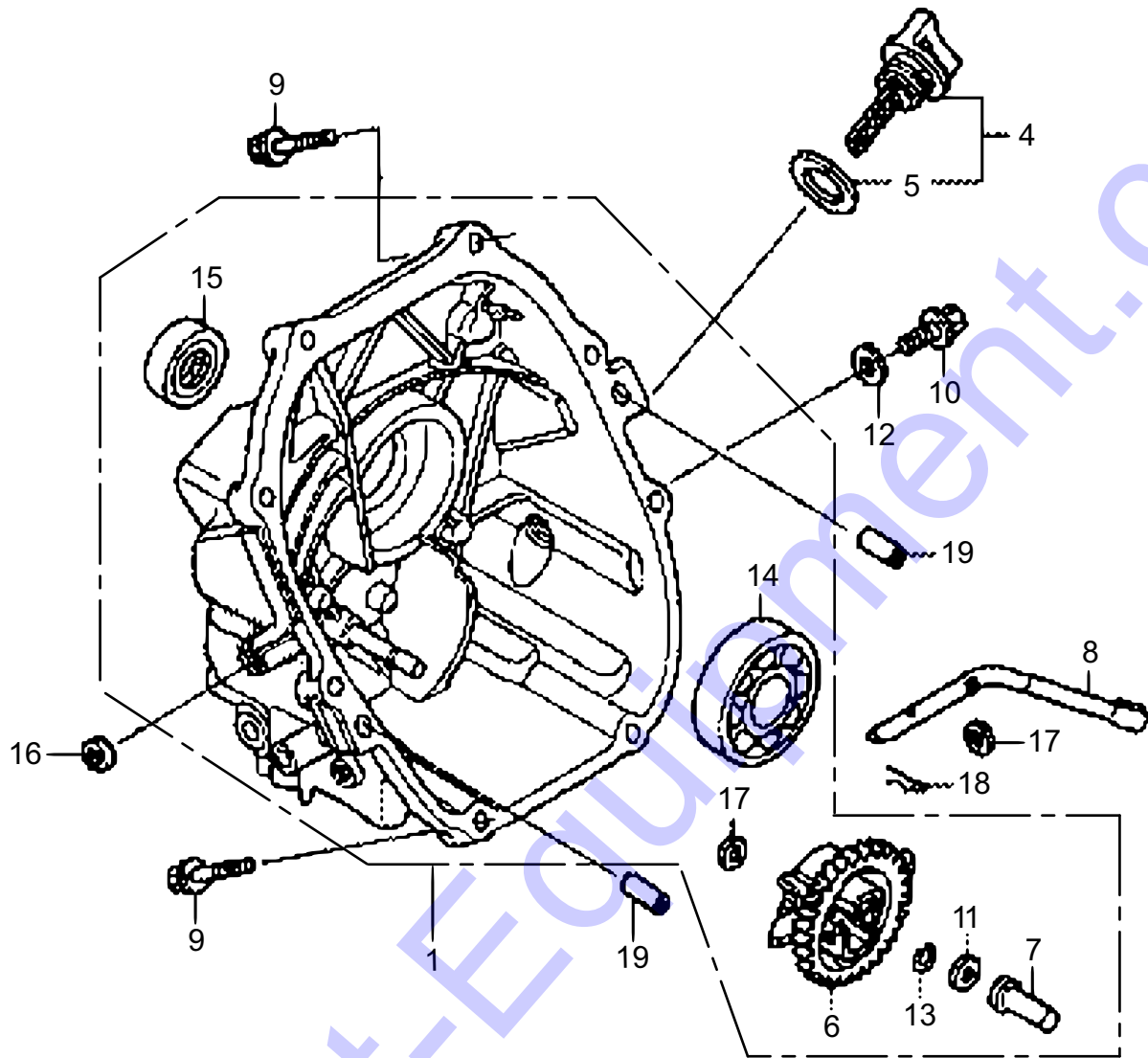

HONDA GXR120RTKRB ENG. — CRANKCASE COVER ASSY.

<u>NO.</u>	<u>PART NO.</u>	<u>PART NAME</u>	<u>QTY.</u>	<u>REMARKS</u>
1	11300ZDJ305	COVER ASSY., CRANKCASE.....	1.....	INCLUDES ITEMS W/@
4	15600ZDF000	CAP ASSY., OIL FILLER	1.....	INCLUDES ITEMS W/#
5#	15625Z0T800	PACKING, OIL FILLER CAP	1	
6@	16510ZL8000	GOVERNOR ASSY.	1	
7@	16531ZE1000	SLIDER, GOVERNOR	1	
8	16541Z0D000	SHAFT, GOVERNOR ARM	1	
9	90121952000	BOLT, FLANGE, 6X25	8	
10	90131ZE1000	BOLT, DRAIN PLUG	1	
11@	90451ZE1000	WASHER, THRUST, 6MM	1	
12	90601ZE1000	WASHER, DRAIN PLUG, 10.2MM	1	
13@	90602ZE1000	CLIP, GOVERNOR HOLDER	1	
14@	91001878003	BEARING, RADIAL BALL	1	
15@	91203ZE0013	OIL SEAL, 22X41X6	1	
16	91231891003	OIL SEAL, 6X11X4	1	
17@	9410106800	WASHER, FLAT, 6MM	2	
18	9425108000	PIN, LOCK, 8MM	1	
19	9430108200	DOWEL PIN, 8X20	2	

HONDA GXR120RTKRB ENGINE — CRANKSHAFT ASSY.

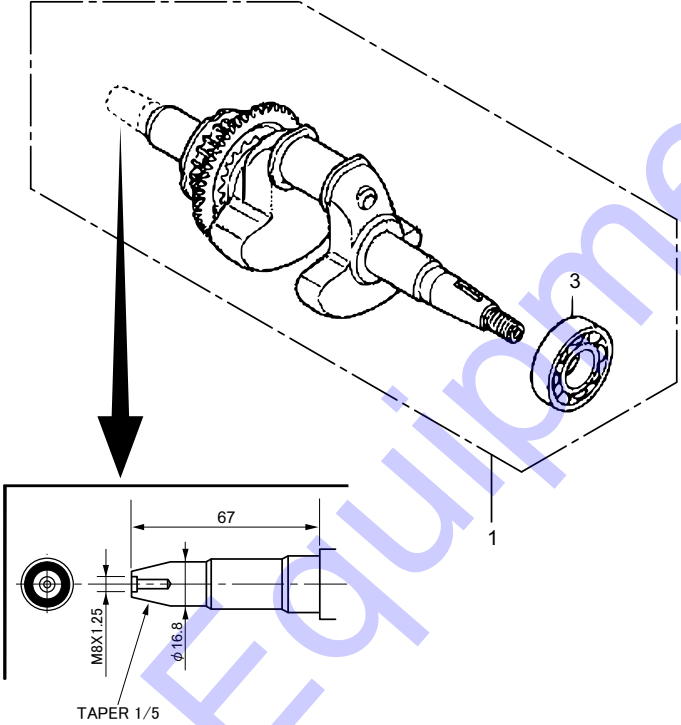

HONDA GXR120RTKRB ENGINE — CRANKSHAFT ASSY.

<u>NO.</u>	<u>PART NO.</u>	<u>PART NAME</u>	<u>QTY.</u>	<u>REMARKS</u>
1	13310ZDJ000	CRANKSHAFT COMPLETE	1.....	INCLUDES ITEM W/#
3#	91005KS4003	BEARING, RADIAL BALL	1	

Discount-Equipment.com

HONDA GXR120RTKRBF ENG. — PISTON/CONN. ROD ASSY.

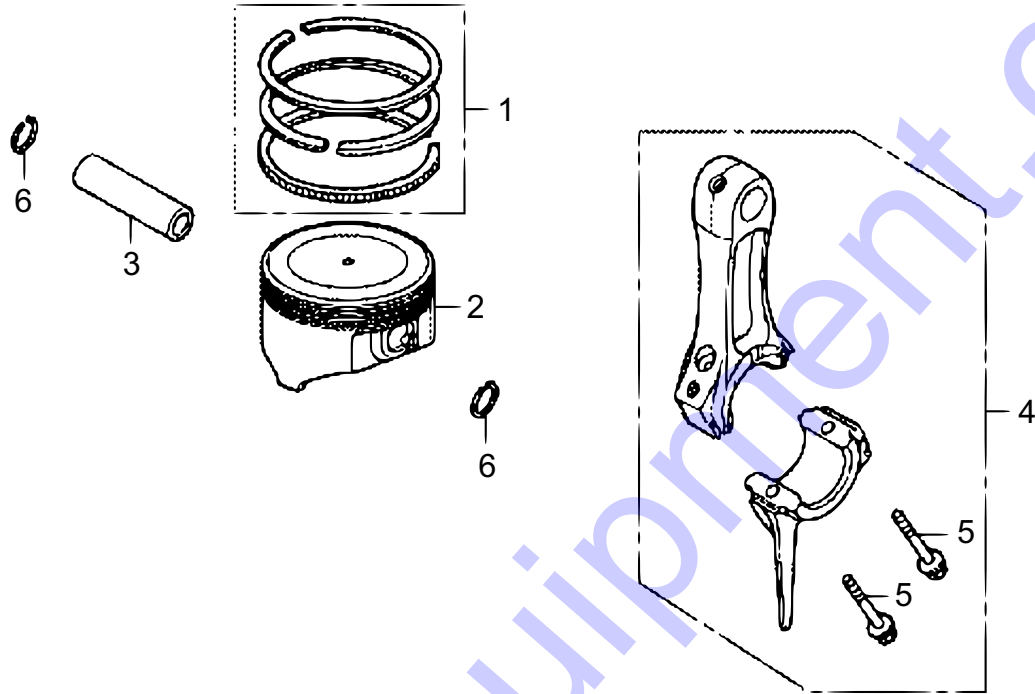

HONDA GXR120RTKRBFB ENG. — PISTON/CONN. ROD ASSY.

<u>NO.</u>	<u>PART NO.</u>	<u>PART NAME</u>	<u>QTY.</u>	<u>REMARKS</u>
1	13010ZDJ003	RING SET, PISTON STD.	1	
2	13101ZDJ000	PISTON	1	
3	13111ZE0000	PISTON PIN	1	
4	13200ZDJ000	CONNECTING ROD ASSY.....	1.....	INCLUDES ITEM W/\$
5\$	90001ZDJ000	CONNECTING ROD BOLT 6X32	2	
6	90551ZE0000	CLIP, PISTON PIN 13MM	2	

HONDA GXR120RTKRB ENG. — CAMSHAFT PULLEY ASSY.

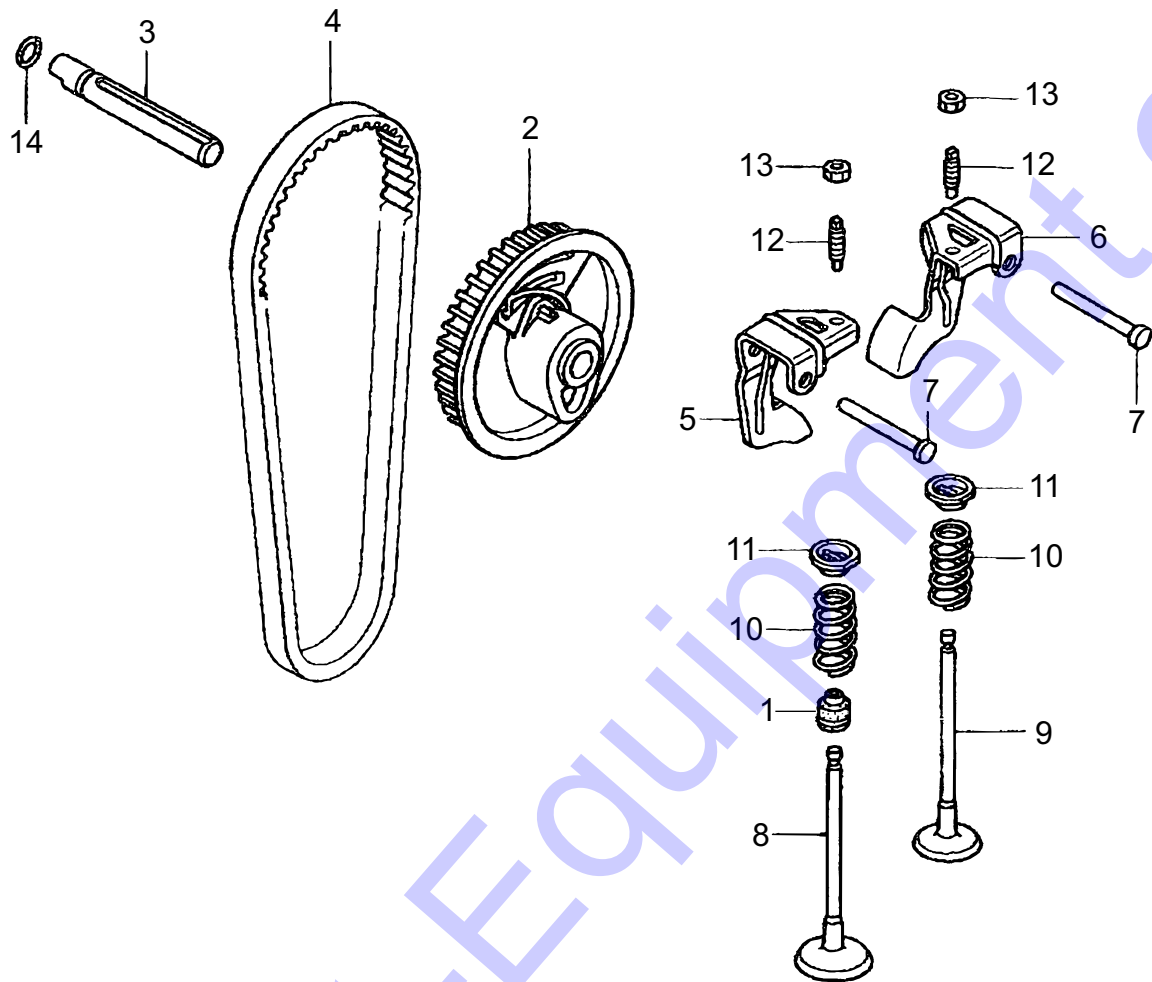

HONDA GXR120RTKRB ENG. — CAMSHAFT PULLEY ASSY.

<u>NO.</u>	<u>PART NO.</u>	<u>PART NAME</u>	<u>QTY.</u>	<u>REMARKS</u>
1	12209KT7013	SEAL, VALVE STEM	1	
2	14320ZDD000	PULLEY COMPLETE, CAMSHAFT	1	
3	14324Z0D000	SHAFT, CAM PULLEY	1	
4	14400Z0D003	TIMING BELT	1	
5	14431ZDD000	ROCKER ARM, INTAKE VALVE	1	
6	14441ZDD000	ROCKER ARM, EXHAUST VALVE	1	
7	14461ZL8000	SHAFT, ROCKER ARM	2	
8	14711Z0D000	VALVE, INLET	1	
9	14721Z0D000	VALVE, EXHAUST	1	
10	14751Z0D000	SPRING, VALVE	2	
11	14771ZM3010	RETAINER, VALVE SPRING	2	
12	90012333000	SCREW, TAPPET ADJUSTING	2	
13	90206001000	NUT, TAPPET ADJUSTING	2	
14	91301ZM0V31	O-RING	1	

HONDA GXR120RTKRBF ENG. — RECOIL STARTER ASSY.

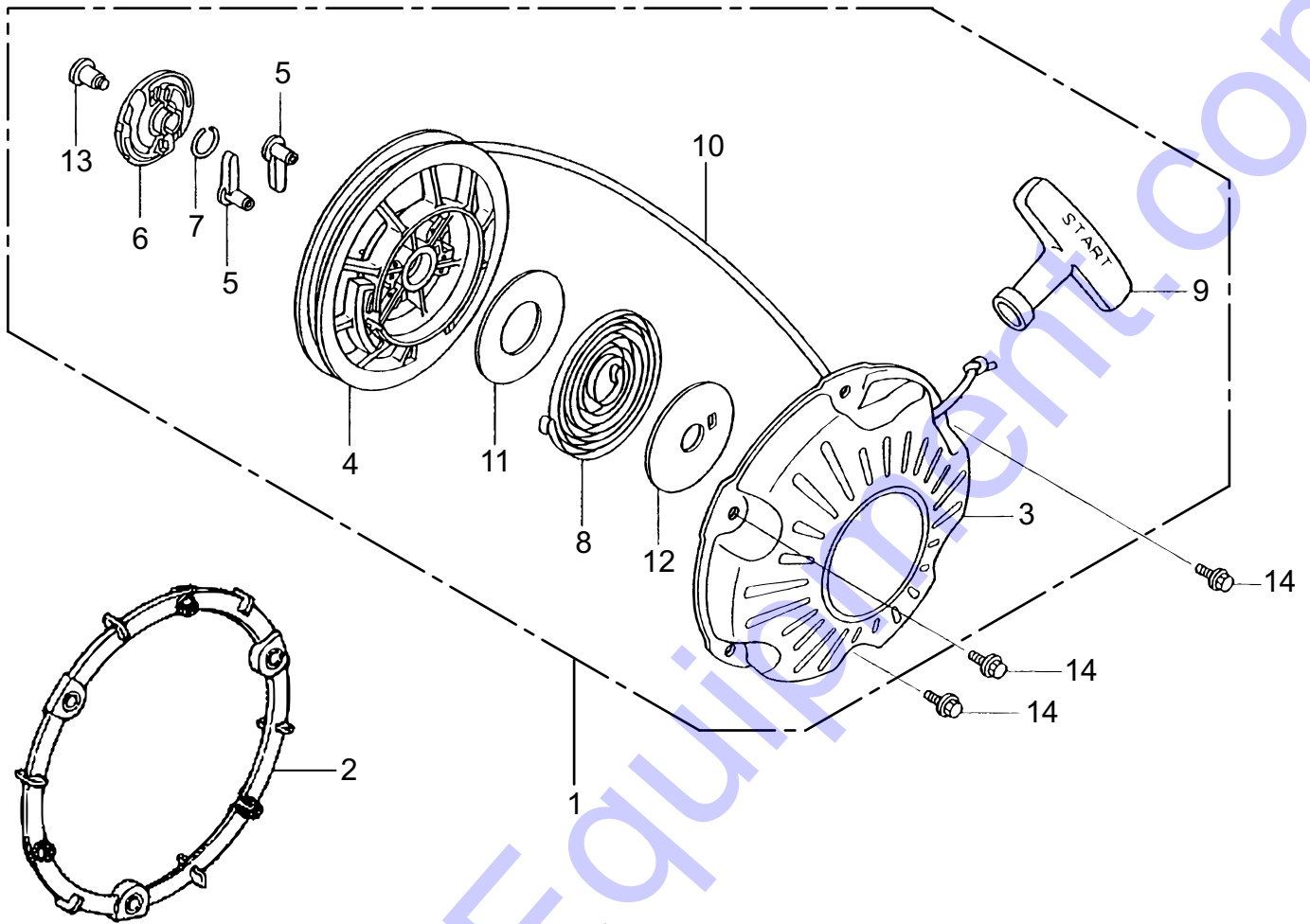

HONDA GXR120RTKRBF ENG. — RECOIL STARTER ASSY.

<u>NO.</u>	<u>PART NO.</u>	<u>PART NAME</u>	<u>QTY.</u>	<u>REMARKS</u>
1	28400ZDJ003ZB	RECOIL STARTER ASSY., BLK.....	1.....	INCLUDES ITEMS W/#
2	28405ZDJ000	SPACER, RECOIL STARTER MOUNTING	1	
3#	28410ZDJ003ZB	CASE COMP., RECOIL STARTER, BLK.	1	
4#	28421Z0DV02	REEL, RECOIL STARTER	1	
5#	28422ZG0W02	RATCHET, STARTER	2	
6#	28433ZG0W02	GUIDE, RATCHET	1	
7#	28441ZW6003	SPRING, FRICTION	1	
8#	28442ZH8003	SPRING, RECOIL STARTER	1	
9#	28461ZH8013	KNOB, RECOIL STARTER	1	
10#	28462Z0DV03	ROPE, RECOIL STARTER	1	
11#	28467Z0DV02	PLATE, SIDE	1	
12#	28468Z0DV02	PLATE, SLIDE	1	
13#	90003ZH8003	SCREW, SETTING	1	
14	957010601400	BOLT, FLANGE 6X14	3	

HONDA GXR120RTKRBF ENGINE — FAN COVER ASSY.

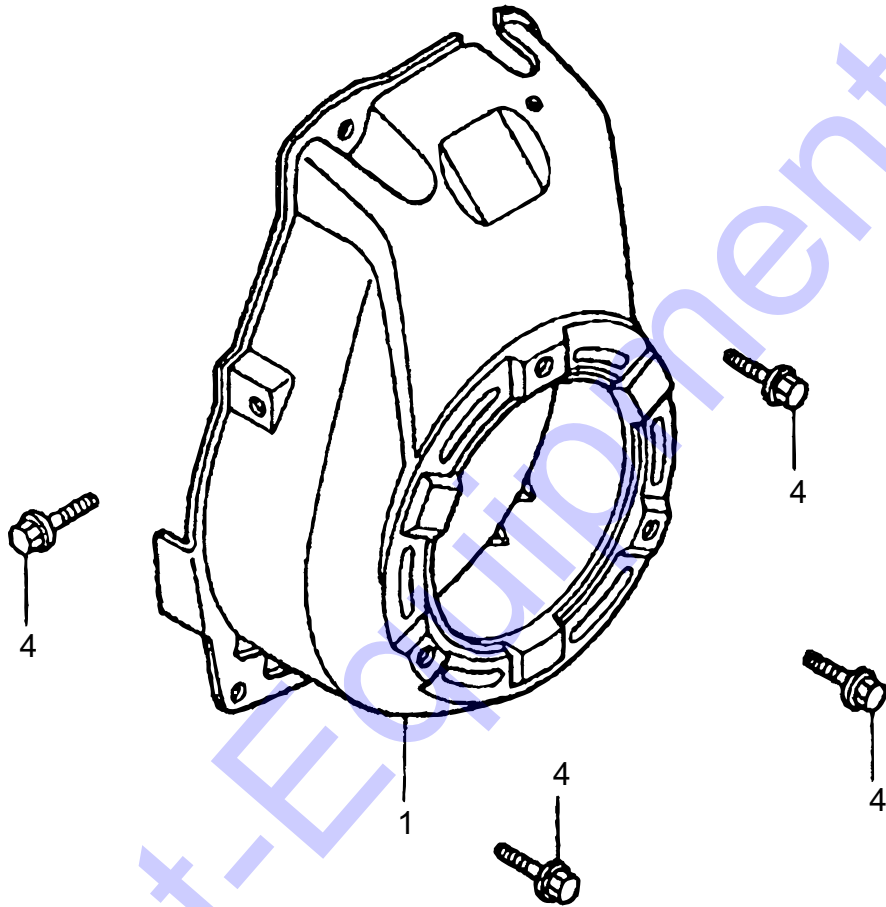

HONDA GXR120RTKRB ENGINE — FAN COVER ASSY.

<u>NO.</u>	<u>PART NO.</u>	<u>PART NAME</u>	<u>QTY.</u>	<u>REMARKS</u>
1	19610Z4ES30ZA	FAN COVER COMPLETE, BLK	1	
4	90014952000	BOLT, FLANGE 6X14	4	

HONDA GXR120RTKRBF ENGINE — CARBURETOR ASSY.

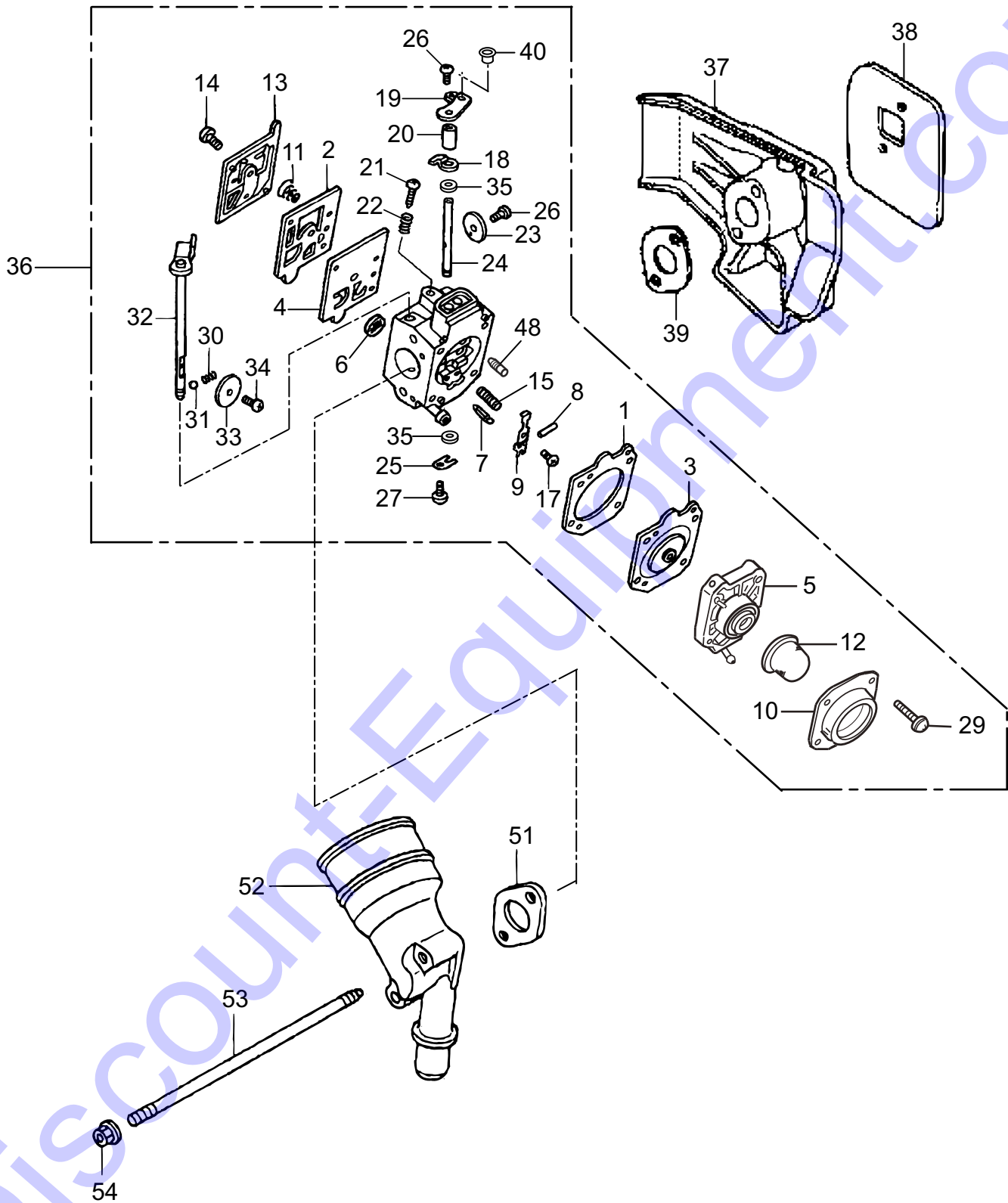

HONDA GXR120RTKRB ENGINE — CARBURETOR ASSY.

NO.	PART NO.	PART NAME	QTY.	REMARKS
1\$	16010Z0DV02	GASKET, METERING DIAPHRAGM	1	
2\$	16011Z0DV02	GASKET, PUMP	1	
3\$	16013Z4ES44	DIAPHRAGM ASSY., METERING	1	
4\$	16014Z0DV02	DIAPHRAGM, PUMP	1	
5\$	16017Z4ES32	BODY ASSY., AIR PURGE	1	
6\$	16018ZM3004	SCREEN, INLET	1	
7\$	16019ZM3004	VALVE, INLET NEEDLE	1	
8\$	16022ZM3014	PIN, METERING LEVER	1	
9\$	16023Z0DV02	LEVER, METERING	1	
10\$	16026Z4ES32	COVER, PRIMER PUMP	1	
11\$	16030ZM3004	SPRING, PUMP	1	
12\$	16032Z4ES32	PUMP, PRIMER	1	
13\$	16040Z4E802	COVER, PUMP	1	
14\$	16041Z0DV02	SCREW	1	
15\$	16042Z0DV02	SPRING	1	
17\$	16044Z4E802	SCREW	1	
18\$	16045Z0DV02	STOPPER, THROTTLE LEVER	1	
19\$	16046Z0DV73	LEVER, THROTTLE	1	
20\$	16048Z0DV02	SPACER, THROTTLE LEVER	1	
21\$	16049Z4ES12	SCREW, IDLE ADJUSTING	1	
22\$	16050Z0DV02	SPRING	1	
23\$	16051Z4ES44	VALVE, THROTTLE	1	
24\$	16052Z0DV02	SHAFT, THROTTLE	1	
25\$	16053Z0DV02	CLIP, THROTTLE SHAFT	1	
26\$	16054Z0DV02	SCREW, VALVE	2	
27\$	16055Z0DV02	SCREW ASSY.	1	
29\$	16055Z4ES32	SCREW ASSY.	4	
30\$	16056Z0DV02	SPRING	1	
31\$	16057Z0DV02	BALL	1	
32\$	16058Z0DV02	SHAFT ASSY., CHOKE	1	
33\$	16059Z0DV03	VALVE, CHOKE	1	
34\$	16060Z0DV02	SCREW	1	
35\$	16061Z0DV02	SEAL, DUST	2	
36	16100ZDJ813	CARBURETOR ASSY.....	1	INCLUDES ITEMS W/\$
37	16211ZDJ000	INSULATOR, CARBURETOR	1	
38	16212Z0DV00	PACKING, INSULATOR	1	
39	16221Z0DV00	PACKING, CARBURETOR	1	
40\$	16552896650	COLLAR, LEVER	1	
48\$	99101Z0D0480	JET	1	
51	17228Z0DV01	PACKING, AIR CLEANER	1	
52	17410Z4ES31	ELBOW, AIR CLEANER	1	
53	90042ZDJ810	BOLT, STUD 5X95	2	
54	9405005000	NUT, FLANGE 5MM	2	

HONDA GXR120RTKRBF ENGINE — MUFFLER ASSY.

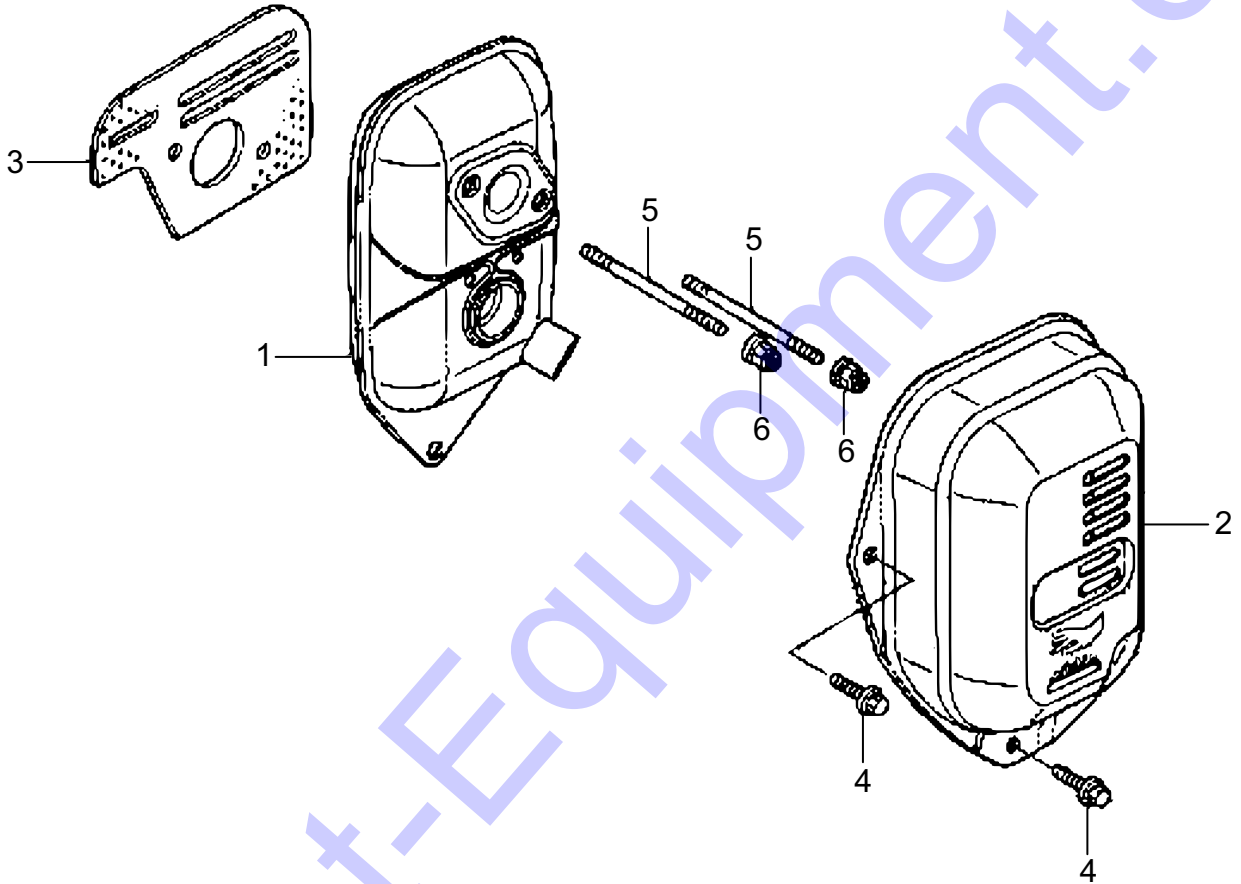

HONDA GXR120RTKRB ENGINE — MUFFLER ASSY.

<u>NO.</u>	<u>PART NO.</u>	<u>PART NAME</u>	<u>QTY.</u>	<u>REMARKS</u>
1	18310ZDJ000	MUFFLER COMPLETE (RAMMER)	1	
2	18320ZDJ000	MUFFLER PROTECTOR COMP., (RAMMER)	1	
3	18381Z0D000	GASKET, MUFFLER	1	
4	90014952000	BOLT, FLANGE, 6X14	3	
5	90048ZDJ000	BOLT, STUD, 6X56.5	2	
6	90343ZE6000	NUT, SELF-LOCK, 6MM	2	

HONDA GXR120RTKRB ENG. — FLYWHEEL IGNITION ASSY.

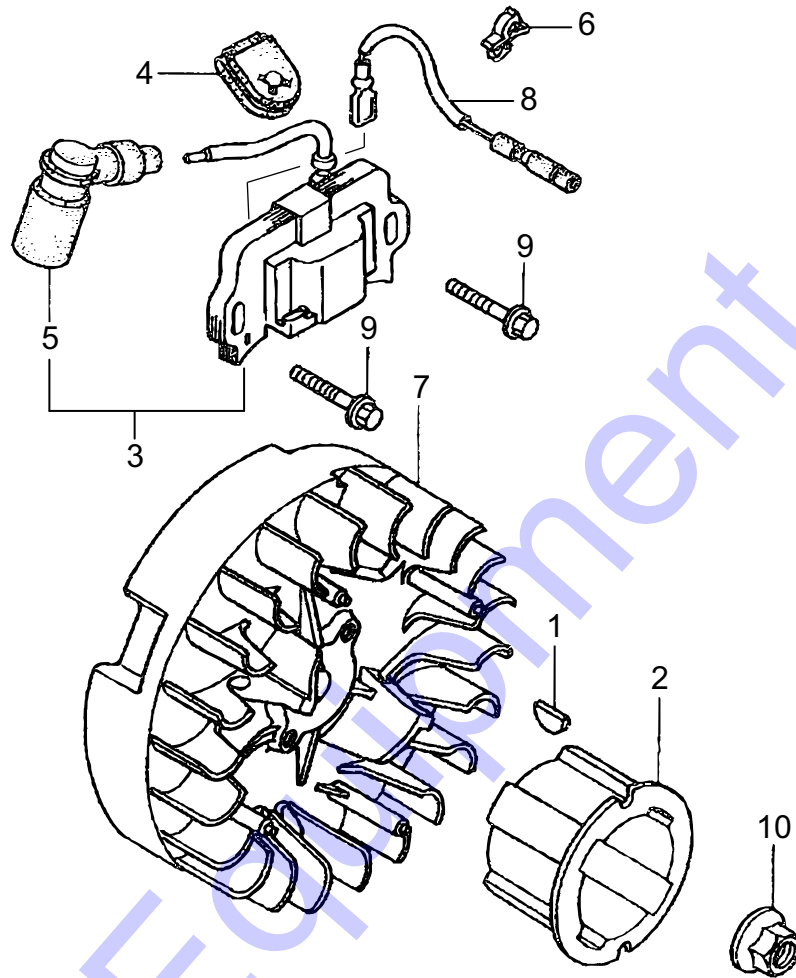

HONDA GXR120RTKRB ENG. — FLYWHEEL IGNITION ASSY.

<u>NO.</u>	<u>PART NO.</u>	<u>PART NAME</u>	<u>QTY.</u>	<u>REMARKS</u>
1	13331357000	KEY, SPECIAL WOODRUFF, 25X18	1	
2	28451ZDJ003	PULLEY, STARTER	1	
3	30500Z0DV02	COIL ASSY., IGNITION	1.....	INCLUDES ITEMS W/\$
4	30564ZA5000	GROMMET, CORD	1	
5\$	30700Z0DV01	TERMINAL ASSY., HIGH TENSION	1	
6	30701883000	CLIP, HIGH TENSION CORD	1	
7	31110ZDJ003	FLYWHEEL COMPLETE	1	
8	32195Z0D000	CORD, STOP SWITCH	1	
9	90022888010	BOLT, FLANGE, 6X20	2	
10	90201Z0T800	NUT, SPECIAL 14MM	1	

HONDA GXR120RTKRBF ENGINE — CONTROL ASSY.

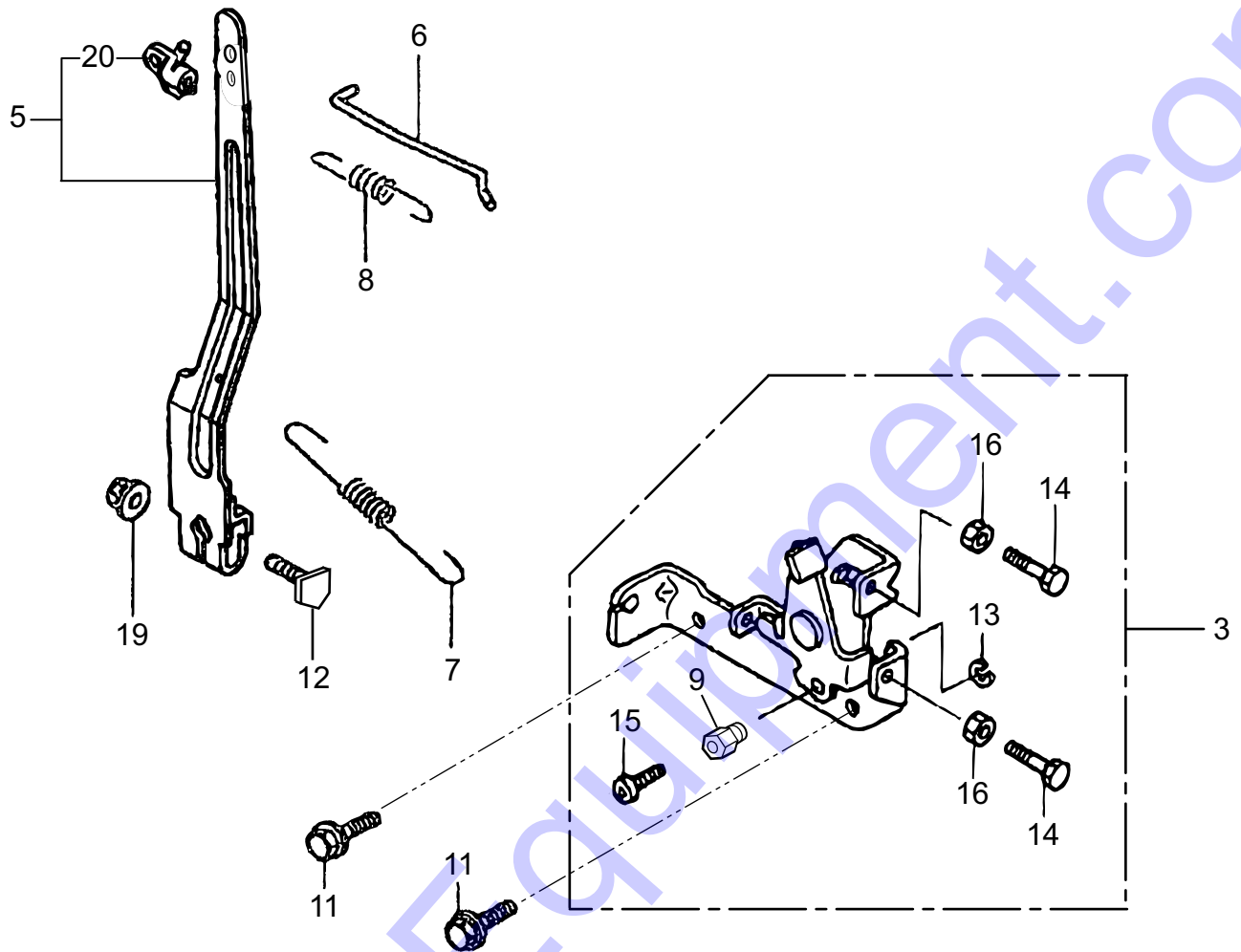

HONDA GXR120RTKRBF ENGINE — CONTROL ASSY.

<u>NO.</u>	<u>PART NO.</u>	<u>PART NAME</u>	<u>QTY.</u>	<u>REMARKS</u>
3	16500Z4ES30	CONTROL ASSY.....	1.....	INCLUDES ITEMS W/#
5	16550Z0DV01	ARM COMPLETE, GOVERNOR	1.....	INCLUDES ITEMS W/@
6	16555Z0DV00	ROD, GOVERNOR	1	
7	16561ZDJ000	SPRING, GOVERNOR	1	
8	16562ZDJ000	SPRING, THROTTLE RETURN	1	
9#	16594883010	HOLDER, WIRE	1	
11	90014952000	BOLT, FLANGE 6X14	2	
12	90015Z5T000	BOLT, GOVERNOR ARM	1	
13#	90605230000	CIRCLIP, 5MM	1	
14#	92301050200A	BOLT, RECESSED, 5X20	2	
15#	93500040060H	SCREW, PAN 4X6	1	
16#	9400105000	NUT, HEX. 5MM	2	
19	9405006000	NUT, FLANGE 6MM	1	
20@	16263883W10	JOINT, ROD	1	

HONDA GXR120RTKRBF ENGINE — TOOL/LABELS ASSY.

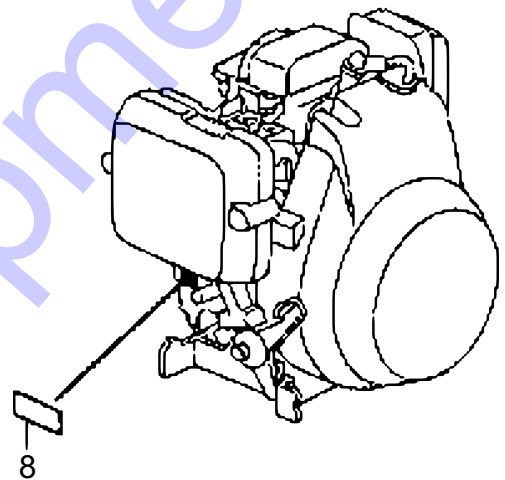
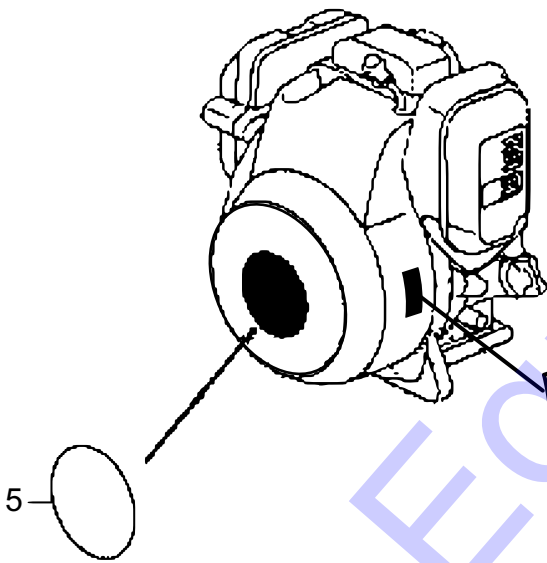
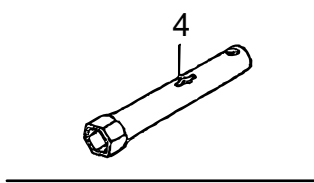

HONDA GXR120RTKRBF ENGINE — TOOL/LABELS ASSY.

<u>NO.</u>	<u>PART NO.</u>	<u>PART NAME</u>	<u>QTY.</u>	<u>REMARKS</u>
4	89216045670	WRENCH, PLUG	1	
5	87521ZDJ000	EMBLEM	1	
7	87539Z0J000	MARK, EX, CAUTION(ENGLISH)	1	
8	87601Z4ES30	MARK, TYPE (KRBF)	1	

Discount Equipment

Discount-Equipment.com is your online resource for commercial and industrial quality parts and equipment sales.

Locations:

Florida (West Palm Beach): [561-964-4949](tel:561-964-4949)

Outside Florida TOLL FREE: [877-690-3101](tel:877-690-3101)

Need parts? Check out our website at www.discount-equipment.com

Can't find what you need?

Click on this link: <http://www.discount-equipment.com/category/5443-parts/> and fill out the request form.

Please have the machine model and serial number available in order to help us get you the correct parts. One of our experienced staff members will get back to you with a quote for the right part that your machine needs.

We sell worldwide for the brands: Genie, Terex, JLG, MultiQuip, Mayco, Toro/Stone, Diamond Products, Magnum, Airman, Mustang, Power Blanket, Nifty Lift, Atlas Copco, Chicago Pneumatic, Allmand Brothers, Essick, Miller Spreader, Skyjack, Lull, Skytrak, Tsurumi, Husquvarna/Target, Whiteman-Concrete/Mortar, Stow-Concrete/Mortar, Baldor, Wacker, Sakai, Snorkel, Upright, Mi-T-M, Sullair, Neal, Basic, Dynapac, MBW, Weber, Bartell, Bennar Newman, Haulotte, Ditch Runner, Blaw-Knox, Himoina, Best, Buddy, Crown, Edco, Wyco, Bomag, Laymor, Terremite, Barreto, EZ Trench, Takeuchi, Basic, Bil-Jax, Curtis, Gehl, Heli, Honda, ICS/PowerGrit, Puckett, Waldon, ASV, IHI, Partner, Imer, Clipper, MMD, Koshin, Rice, Gorman Rupp, CH&E, Cat Pumps, Comet, General Pump, Giant, AMida, Coleman, NAC, Gradall, Square Shooter, Kent, Stanley, Tamco, Toku, Hatz, Kohler, Robin, Wisconsin, Northrock, Oztec, Toker TK, Rol-Air, Small Line, Wanco, Yanmar

New Equipment - Used Equipment - Rental Equipment - Parts and Accessories

Discount Equipment

www.discount-equipment.com

561-964-4949

Sales: info@Discount-Equipment.com

Parts: wbparts@Discount-Equipment.com