

# OPERATION AND PARTS MANUAL



## MODEL QP4TH TRASH PUMP

(HONDA GX340K1QA2/GX340U1QA2/GX340UT2QA2  
GASOLINE ENGINE)

Revision #3 (01/29/14)



[www.discount-equipment.com](http://www.discount-equipment.com)

THIS MANUAL MUST ACCOMPANY THE EQUIPMENT AT ALL TIMES.

# **Discount Equipment**

Discount-Equipment.com is your online resource for commercial and industrial quality parts and equipment sales.

## **Locations:**

Florida (West Palm Beach): [561-964-4949](tel:561-964-4949)

Outside Florida TOLL FREE: [877-690-3101](tel:877-690-3101)

**Need parts?** Check out our website at [www.discount-equipment.com](http://www.discount-equipment.com)

## **Can't find what you need?**

Click on this link: <http://www.discount-equipment.com/category/5443-parts/> and fill out the request form.

Please have the machine model and serial number available in order to help us get you the correct parts. One of our experienced staff members will get back to you with a quote for the right part that your machine needs.

We sell worldwide for the brands: Genie, Terex, JLG, MultiQuip, Mayco, Toro/Stone, Diamond Products, Magnum, Airman, Mustang, Power Blanket, Nifty Lift, Atlas Copco, Chicago Pneumatic, Allmand Brothers, Essick, Miller Spreader, Skyjack, Lull, Skytrak, Tsurumi, Husquyarna/Target, Whiteman-Concrete/Mortar, Stow-Concrete/Mortar, Baldor, Wacker, Sakai, Snorkel, Upright, Mi-T-M, Sullair, Neal, Basic, Dynapac, MBW, Weber, Bartell, Bennar Newman, Haulotte, Ditch Runner, Blaw-Knox, Himoina, Best, Buddy, Crown, Edco, Wyco, Bomag, Laymor, Terremite, Barreto, EZ Trench, Takeuchi, Basic, Bil-Jax, Curtis, Gehl, Heli, Honda, ICS/PowerGrit, Puckett, Waldon, ASV, IHI, Partner, Imer, Clipper, MMD, Koshin, Rice, Gorman Rupp, CH&E, Cat Pumps, Comet, General Pump, Giant, AMida, Coleman, NAC, Gradall, Square Shooter, Kent, Stanley, Tamco, Toku, Hatz, Kohler, Robin, Wisconsin, Northrock, Oztec, Toker TK, Rol-Air, Small Line, Wanco, Yanmar

## PROPOSITION 65 WARNING

---



### **CALIFORNIA — Proposition 65 Warning**

Gasoline engine exhaust and some of its constituents are known to the State of California to cause cancer, birth defects and other reproductive harm.

# TABLE OF CONTENTS

---

## QP4TH Centrifugal Pump

Proposition 65 Warning .....	2
Table Of Contents .....	4
Parts Ordering Procedures .....	5
Safety Information .....	6-10
Specifications (Pump).....	11
Specifications (Engine).....	12
General Information.....	13
Pump Components.....	14
Basic Engine.....	15
Inspection (Engine).....	16
Setup .....	17
Operation.....	18-19
Maintenance (Pump) .....	20-21
Maintenance (Engine) .....	22-24
Storage .....	25
Troubleshooting (Engine).....	26
Troubleshooting (Engine/Pump) .....	27
Explanation Of Code In Remarks Column.....	28
Suggested Spare Parts .....	29

## Component Drawings

Pump Assembly.....	30-33
Engine Service Parts.....	34-35
Terms And Conditions Of Sale — Parts .....	36

### NOTICE

Specifications and part numbers are subject to change without notice.

# SAFETY INFORMATION

Do not operate or service the equipment before reading the entire manual. Safety precautions should be followed at all times when operating this equipment. Failure to read and understand the safety messages and operating instructions could result in injury to yourself and others.



## SAFETY MESSAGES

The four safety messages shown below will inform you about potential hazards that could injure you or others. The safety messages specifically address the level of exposure to the operator and are preceded by one of four words: **DANGER**, **WARNING**, **CAUTION** or **NOTICE**.

## SAFETY SYMBOLS

**! DANGER**

Indicates a hazardous situation which, if not avoided, **WILL** result in **DEATH** or **SERIOUS INJURY**.

**! WARNING**

Indicates a hazardous situation which, if not avoided, **COULD** result in **DEATH** or **SERIOUS INJURY**.

**! CAUTION**

Indicates a hazardous situation which, if not avoided, **COULD** result in **MINOR** or **MODERATE INJURY**.

**NOTICE**

Addresses practices not related to personal injury.

Potential hazards associated with the operation of this equipment will be referenced with hazard symbols which may appear throughout this manual in conjunction with safety messages.

Symbol	Safety Hazard
	Lethal exhaust gas hazards
	Explosion hazards
	Burn hazards
	Pressurized fluid hazards
	Battery acid hazards
	Eye safety hazards

# SAFETY INFORMATION

## GENERAL SAFETY

### CAUTION

- **NEVER** operate this equipment without proper protective clothing, shatterproof glasses, respiratory protection, hearing protection, steel-toed boots and other protective devices required by the job or city and state regulations.



- **NEVER** operate this equipment when not feeling well due to fatigue, illness or when under medication.



- **NEVER** operate this equipment under the influence of drugs or alcohol.



### NOTICE

- This equipment should only be operated by trained and qualified personnel 18 years of age and older.
- Whenever necessary, replace nameplate, operation and safety decals when they become difficult to read.
- Manufacturer does not assume responsibility for any accident due to equipment modifications. Unauthorized equipment modification will void all warranties.
- **NEVER** use accessories or attachments that are not recommended by Multiquip for this equipment. Damage to the equipment and/or injury to user may result.
- **ALWAYS** know the location of the nearest fire extinguisher.
- **ALWAYS** know the location of the nearest first aid kit.
- **ALWAYS** know the location of the nearest phone or **keep a phone on the job site**. Also, know the phone numbers of the nearest ambulance, doctor and fire department. This information will be invaluable in the case of an emergency.



## PUMP SAFETY

### DANGER

- **NEVER** pump volatile, explosive, flammable or low flash point fluids. These fluids could ignite or explode.
- The engine fuel exhaust gases contain poisonous carbon monoxide. This gas is colorless and odorless, and can cause death if inhaled.
- The engine of this equipment requires an adequate free flow of cooling air. **NEVER** operate this equipment in any enclosed or narrow area where free flow of the air is restricted. If the air flow is restricted it will cause injury to people and property and serious damage to the equipment or engine.



- **NEVER** operate the equipment in an explosive atmosphere or near combustible materials. An explosion or fire could result causing severe **bodily harm or even death**.



### WARNING

- **NEVER** pump corrosive chemicals or water containing toxic substances. These fluids could create serious health and environmental hazards. Contact local authorities for assistance.
- **NEVER** open the priming plug when pump is hot. Hot water inside could be pressurized much like the radiator of an automobile. Allow pump to cool to the touch before loosening plug. The possibility exists of scalding, resulting in severe bodily harm.
- **NEVER** disconnect any emergency or safety devices. These devices are intended for operator safety. Disconnection of these devices can cause severe injury, bodily harm or even death. Disconnection of any of these devices will void all warranties.



# SAFETY INFORMATION

## CAUTION

- **NEVER** lubricate components or attempt service on a running machine.
- **NEVER** block or restrict flow from discharge hose. Remove kinks from discharge line before starting pump. Operation with a blocked discharge line can cause water inside pump to overheat.

## NOTICE

- **ALWAYS** fill the pump casing with water before starting the engine. Failure to maintain water inside the pump housing will cause severe damage to the pump and mechanical seal.
- In winter drain water from pump housing to prevent freezing.
- **NEVER** start the pump with the clean-out cover removed. The rotating impeller inside the pump can cut or sever objects caught in it. Before starting the pump, check that the clean-out cover is securely fastened.
- **ALWAYS** keep the machine in proper running condition.
- **ALWAYS** ensure pump is on level ground before use.
- Fix damage to machine and replace any broken parts immediately.
- **ALWAYS** store equipment properly when it is not being used. Equipment should be stored in a clean, dry location out of the reach of children and unauthorized personnel.

## ENGINE SAFETY

### WARNING

- **NEVER** operate the engine with heat shields or guards removed.
- **DO NOT** remove the engine oil drain plug while the engine is hot. Hot oil will gush out of the oil tank and severely scald any persons in the general area of the pump.



### CAUTION

- **NEVER** touch the hot exhaust manifold, muffler or cylinder. Allow these parts to cool before servicing equipment.



## NOTICE

- **NEVER** run engine without an air filter or with a dirty air filter. Severe engine damage may occur. Service air filter frequently to prevent engine malfunction.
- **NEVER** tamper with the factory settings of the engine or engine governor. Damage to the engine or equipment can result if operating in speed ranges above the maximum allowable.



## FUEL SAFETY

### DANGER

- **DO NOT** add fuel to equipment if it is placed inside truck bed with plastic liner. Possibility exists of explosion or fire due to static electricity.

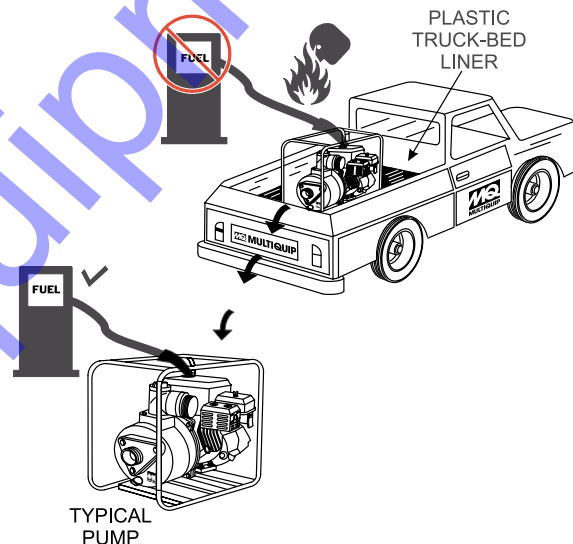

- **DO NOT** start the engine near spilled fuel or combustible fluids. Fuel is extremely flammable and its vapors can cause an explosion if ignited.
- **ALWAYS** refuel in a well-ventilated area, away from sparks and open flames.
- **ALWAYS** use extreme caution when working with flammable liquids.
- **DO NOT** fill the fuel tank while the engine is running or hot.
- **DO NOT** overfill tank, since spilled fuel could ignite if it comes into contact with hot engine parts or sparks from the ignition system.



# SAFETY INFORMATION

- Store fuel in appropriate containers, in well-ventilated areas and away from sparks and flames.
- **NEVER** use fuel as a cleaning agent.
- **DO NOT** smoke around or near the equipment. Fire or explosion could result from fuel vapors or if fuel is spilled on a hot engine. 

## BATTERY SAFETY (ELECTRIC START ONLY)

### DANGER

- **DO NOT** drop the battery. There is a possibility that the battery will explode.
- **DO NOT** expose the battery to open flames, sparks, cigarettes, etc. The battery contains combustible gases and liquids. If these gases and liquids come into contact with a flame or spark, an explosion could occur. 

### WARNING

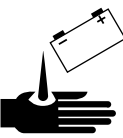
- **ALWAYS** wear safety glasses when handling the battery to avoid eye irritation. The battery contains acids that can cause injury to the eyes and skin. 
- Use well-insulated gloves when picking up the battery.
- **ALWAYS** keep the battery charged. If the battery is not charged, combustible gas will build up.
- **DO NOT** charge battery if frozen. Battery can explode. When frozen, warm the battery to at least 61°F (16°C).
- **ALWAYS** recharge the battery in a well-ventilated environment to avoid the risk of a dangerous concentration of combustible gases.
- If the battery liquid (dilute sulfuric acid) comes into contact with **clothing or skin**, rinse skin or clothing immediately with plenty of water. 
- If the battery liquid (dilute sulfuric acid) comes into contact with **eyes**, rinse eyes immediately with plenty of water and contact the nearest doctor or hospital to seek medical attention.

### CAUTION

- **ALWAYS** disconnect the **NEGATIVE battery terminal** before performing service on the equipment.
- **ALWAYS** keep battery cables in good working condition. Repair or replace all worn cables.

## TRANSPORTING SAFETY

### CAUTION

- **NEVER** allow any person or animal to stand underneath the equipment while lifting.

### NOTICE

- Before lifting, make sure that the equipment parts (hook and vibration insulator) are not damaged and screws are not loose or missing.
- Always make sure crane or lifting device has been properly secured to the lifting bail (hook) of the equipment.
- **ALWAYS** shutdown engine before transporting.
- **NEVER** lift the equipment while the engine is running.
- Tighten fuel tank cap securely and close fuel cock to prevent fuel from spilling.
- Use adequate lifting cable (wire or rope) of sufficient strength.
- Use one point suspension hook and lift straight upwards.

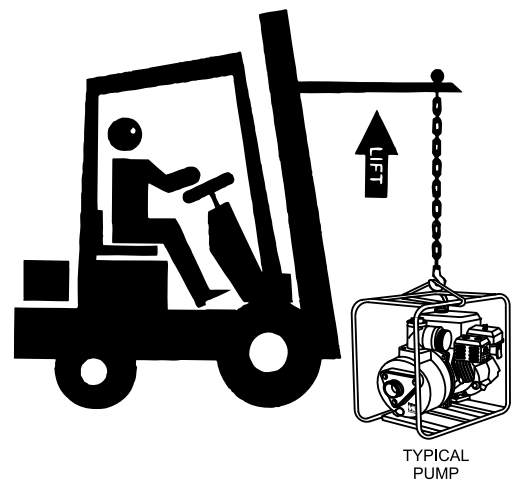

- **DO NOT** lift machine to unnecessary heights.
- **ALWAYS** tie down equipment during transport by securing the equipment with rope.



# SAFETY INFORMATION

## ENVIRONMENTAL SAFETY/DECOMMISSIONING

### NOTICE

Decommissioning is a controlled process used to safely retire a piece of equipment that is no longer serviceable. If the equipment poses an unacceptable and unrepairable safety risk due to wear or damage or is no longer cost effective to maintain (beyond life-cycle reliability) and is to be decommissioned (demolition and dismantlement), be sure to follow rules below.

- **DO NOT** pour waste or oil directly onto the ground, down a drain or into any water source.
- Contact your country's Department of Public Works or recycling agency in your area and arrange for proper disposal of any electrical components, waste or oil associated with this equipment.
- When the life cycle of this equipment is over, remove battery and bring to appropriate facility for lead reclamation. Use safety precautions when handling batteries that contain sulfuric acid.
- When the life cycle of this equipment is over, it is recommended that the trowel frame and all other metal parts be sent to a recycling center.



Metal recycling involves the collection of metal from discarded products and its transformation into raw materials to use in manufacturing a new product.

Recyclers and manufacturers alike promote the process of recycling metal. Using a metal recycling center promotes energy cost savings.

## EMISSIONS INFORMATION

### NOTICE

The gasoline engine used in this equipment has been designed to reduce harmful levels of carbon monoxide (CO), hydrocarbons (HC) and nitrogen oxides (NOx) contained in gasoline exhaust emissions.

This engine has been certified to meet US EPA Evaporative emissions requirements in the installed configuration.

Attempting to modify or make adjustments to the engine emission system by unauthorized personnel without proper training could damage the equipment or create an unsafe condition.

Additionally, modifying the fuel system may adversely affect evaporative emissions, resulting in fines or other penalties.

### Emission Control Label

The emission control label is an integral part of the emission system and is strictly controlled by regulation(s).

The label must remain with the engine for its entire life.

If a replacement emission label is needed, please contact your authorized engine distributor.

## SPECIFICATIONS (PUMP)

Table 1. Specifications (Pump)		
<b>Pump</b>	<b>Model</b>	<b>QP4TH</b>
	Type	Trash Pump
	Suction	4.0 in. (100 mm.)
	Discharge Size	4.0 in. (100 mm.)
	Maximum Pumping Capacity	555 gallons/minute (2,100 liters/minute)
	Max. Solids Diameter	1.57 in. (40 mm)
	Max. Lift	25 ft. (7.62 meters)
	Max. Head	92 ft. (28.0 m)
	Max. Pressure	40 psi (275 kPa)
<b>Dry Net Weight</b>	222 lbs. (100.5 Kg.)	

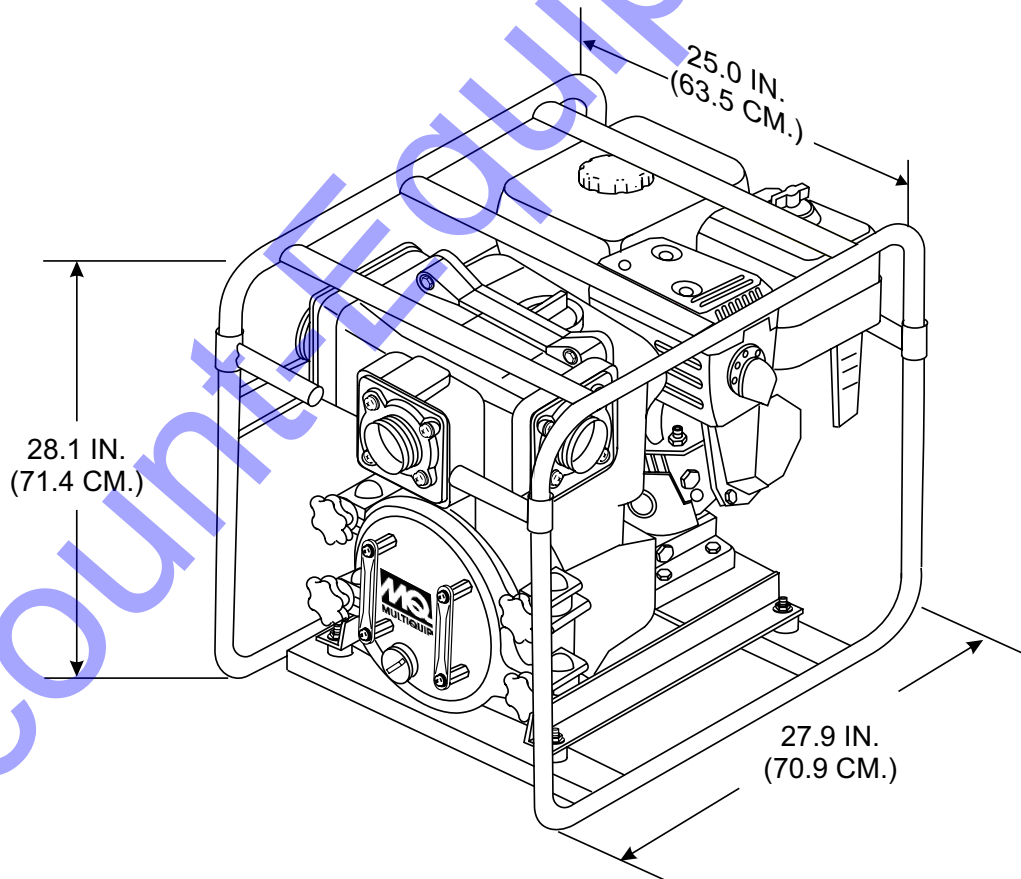
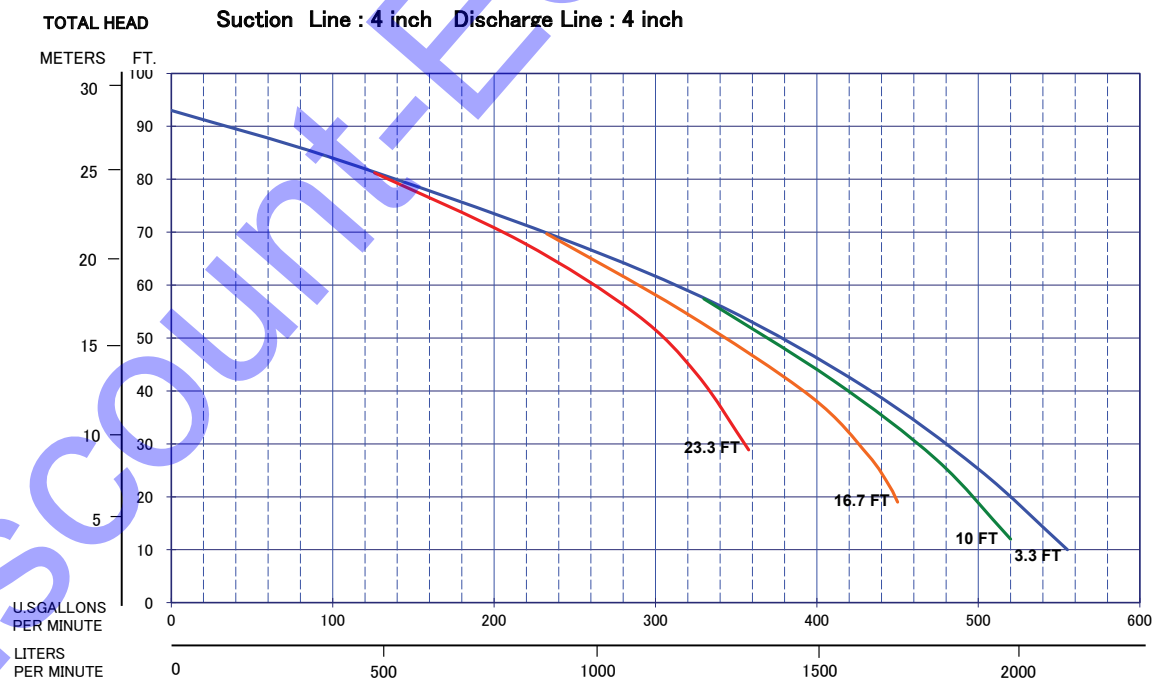

**Figure 1. QP4TH Dimensions**

# SPECIFICATIONS (ENGINE)

Table 2. Specifications (Engines)		
<b>Engine</b>	<b>Model</b>	<b>HONDA GX340K1QA2/ GX340U1QA2/GX340UT2QA2</b>
	<b>Type</b>	Air-cooled 4 stroke, Single Cylinder, OHV, Horizontal Shaft Gasoline Engine
	<b>Bore x Stroke</b>	3.46 in. x 2.28 in. (88 mm x 64 mm)
	<b>Displacement</b>	20.53 cu-in (337 cc)
	<b>Max Output</b>	10.7 H.P.*/3,600 R.P.M.
	<b>Fuel Tank Capacity</b>	Approx. 1.62 U.S. Gallons (6.1 Liters)
	<b>Fuel</b>	Unleaded Automobile Gasoline
	<b>Lube Oil Capacity</b>	1.16 quarts (1.10 liters)
	<b>Speed Control Method</b>	Centrifugal Fly-weight Type
	<b>Starting Method</b>	Recoil Start
<b>Dimension (L x W x H)</b>	15.0 x 17.7 x 17.4 in. (380 x 450 x 443 mm)	
<b>Dry Net Weight</b>	69.4 lbs (31.5 Kg.)	

\* Engine power ratings are calculated by the individual engine manufacturer and the rating method may vary among engine manufacturers. Multiquip Inc. and its subsidiary companies makes no claim, representation or warranty as to the power rating of the engine on this equipment and disclaims any responsibility or liability of any kind whatsoever with respect to the accuracy of the engine power rating. Users are advised to consult the engine manufacturer's owners manual and its website for specific information regarding the engine power rating.



**Figure 2. QP4TH Performance Curve**

# GENERAL INFORMATION

## APPLICATION

The Multiquip QP4TH Trash Pump is designed to be used for dewatering applications. Both the suction and discharge ports on the QP4TH trash pump use a 4-inch diameter opening, which allows the pump to pump at a rate of approximately 555 gallons/minute (gpm) or 2,100 liters/minute (lpm).

## TRASH PUMP

Trash pumps derive their name from their ability to handle a greater amount of debris and solids than standard centrifugal pumps. These pumps generally handle solids up to 1/2 the size of the discharge opening making them less likely to clog. Also trash pumps are capable of handling water with 25% solids by weight.

The advantage of using a trash pump is that it can be quickly and easily disassembled in the field "without tools" and easily cleaned when clogged.

## POWER PLANT

This trash pump is powered by a 10.7 horsepower air cooled 4-stroke, single cylinder HONDA GX340 gasoline engine that incorporates a low "Oil Alert Feature."

## OIL ALERT FEATURE

In the event of low oil or no oil, the HONDA GX340 engine has a built-in oil alarm engine shut-down feature. In the event the oil level is low the engine will automatically shutdown.

## SUCTION LIFT

This pump is intended to be used for dewatering applications and is capable of suction lifts up to 25 feet at sea level. For optimal suction lift performance keep the suction hose or line as short as possible. In general always place the pump as close to the water as possible.

## PUMP SUPPORT

The pump should always be placed on solid stationary ground in a level position.

**NEVER** place the pump on **soft soil**. The suction hose or pipe connection should always be checked for tightness and leaks. A small suction leak in the hose or fittings could prevent the pump from priming.

## Elevation

Higher elevations will effect the performance of the pump. Due to less atmospheric pressure at higher altitudes, pumps **DO NOT** have the priming ability that they have at sea level. This is due to the "thinner air" or lack of oxygen at higher altitudes.

A general rule of thumb is that for every 1,000 feet of elevation above sea level a pump will lose one foot of priming ability.

For example, in Flagstaff, Arizona where the elevation is approximately 7,000 feet, the pump would have a suction lift of only 18 feet rather than the 25 feet at sea level. Table 3 shows suction lift at various elevations.

Altitude Feet (Meters)	Suction Lift in Feet (Meters)			
Sea Level	10.0 (3.048)	15.0 (4.572)	20.0 (6.096)	25.0 (7.620)
2,000 (610)	8.80 (2.680)	13.2 (4.023)	17.6 (5.364)	22.0 (6.705)
4,000 (1,219)	7.80 (2.377)	11.7 (3.566)	15.6 (4.754)	19.5 (5.943)
6,000 (1,829)	6.90 (2.103)	10.4 (3.169)	13.8 (4.206)	17.3 (5.273)
8,000 (2,438)	6.20 (1.889)	9.30 (2.834)	12.4 (3.779)	15.5 (4.724)
10,000 (3,048)	5.70 (1.737)	8.60 (2.621)	11.4 (3.474)	14.3 (4.358)

Table 4 shows percentage drops in performance as elevation increases.

Altitude Feet (Meters)	Discharge Flow	Discharge Head
Sea Level	100%	100%
2,000 (610)	97%	95%
4,000 (1,219)	95%	91%
6,000 (1,829)	93%	87%
8,000 (2,438)	91%	83%
10,000 (3,048)	88%	78%

## PUMP COMPONENTS

Figure 3 shows a typical application using the QP4TH centrifugal pump. Please note that this pump is intended for the removal of clean water.

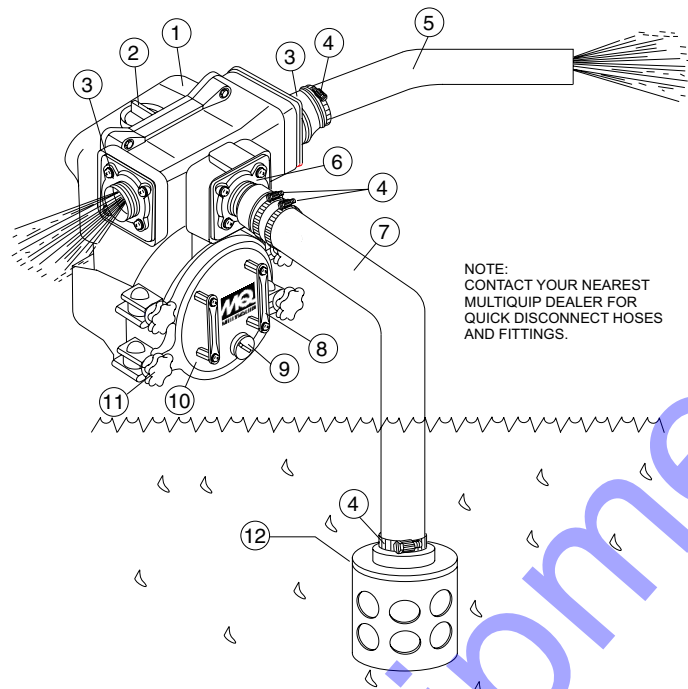

**Figure 3. QP4TH Pump Application**

- 1. Pump** — The model QP4TH is a 4-inch trash pump aused in general dewatering applications. Typical dewatering applications consist of manholes, septic tanks, fast and slow seepage ditch water, silt water, mud water and muck water.
- 2. Fill Cap** — Prior to operation, the pump casing should be filled with water. Remove this cap to add water to the pump. After the initial prime, a sufficient amount of water will be retained in the casing so that the operator will not need to re-prime later.
- 3. Discharge Port** — Connect a 4-inch discharge hose to this port.
- 4. Worm Clamp** — Used to secure the hose to the inlet and outlet ports on the pump. Use two clamps to secure the hose on the inlet side of the pump.
- 5. Discharge Hose** — Connect a flexible rubber hose to the discharge port on the pump. Make sure that the hose lays flat and is not kinked. Use only recommended type discharge hose. Contact Multiquip Parts Department for ordering information.
- 6. Suction Port** — Connect a 3-inch inlet hose to this port. Use two worm clamps to secure the hose.
- 7. Suction Hose** — Connect this flexible rubber hose to the suction port on the pump. Make sure that the hose lays flat and is not kinked. Use only recommended type suction hose. Contact Multiquip parts department for ordering information.
- 8. Clean-out Cover Handles** — To gain access to the pump's clean-out area, grip both handles, then pull to remove cover. Make sure both locking knobs have been released before attempting to remove clean-out cover.
- 9. Drain Plug** — Remove this plug to drain water from the pump.
- 10. Clean-out Cover** — Remove cover to gain access to the clean-out area.
- 11. Locking Knobs** — Turn both knobs clockwise to secure clean-out cover, turn counter-clockwise to release cover.
- 12. Strainer** — Always attach a strainer to bottom side of the suction hose to prevent large objects and debris from entering the pump. Strainer should be positioned so that it will remain completely under water. Running the pump with the strainer above water for long periods can damage pump.

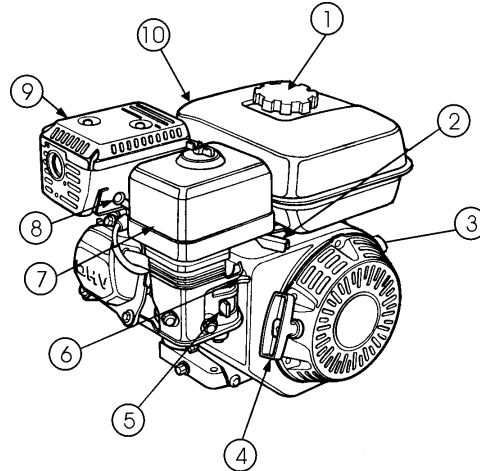

Figure 4. Engine Controls and Components

## INITIAL SERVICING

The engine (See Figure 4) must be checked for proper lubrication and filled with fuel prior to operation. Refer to the manufacturer's engine manual for instructions and details of operation and servicing. The engine shown above is a HONDA engine, operation for other types of engines may vary somewhat.

1. **Fuel Filler Cap** — Remove this cap to add unleaded gasoline to the fuel tank. Make sure cap is tightened securely. **DO NOT** over fill.

### DANGER



Adding fuel to the tank should be done only when the engine is stopped and has had an opportunity to cool down. In the event of a fuel spill, **DO NOT** attempt to start the engine until the fuel residue has been completely wiped up, and the area surrounding the engine is dry.

2. **Throttle Lever** — Used to adjust engine RPM speed (lever advanced forward **SLOW**, lever back toward operator **FAST**).
3. **Engine ON/OFF Switch** — ON position permits engine starting, OFF position stops engine operations.
4. **Recoil Starter (pull rope)** — Manual-starting method. Pull the starter grip until resistance is felt, then pull briskly and smoothly.
5. **Fuel Valve Lever** — **OPEN** to let fuel flow, **CLOSE** to stop the flow of fuel.

6. **Choke Lever** — Used in the starting of a cold engine, or in cold weather conditions. The choke enriches the fuel mixture.
7. **Air Cleaner** — Prevents dirt and other debris from entering the fuel system. Remove wing-nut on top of air filter canister to gain access to filter element.

### NOTICE

Operating the engine without an air filter, with a damaged air filter, or a filter in need of replacement will allow dirt to enter the engine, causing rapid engine wear.

### WARNING



Engine components can generate extreme heat. To prevent burns, **DO NOT** touch these areas while the engine is running or immediately after operating. **NEVER** operate the engine with the muffler removed.

8. **Spark Plug** — Provides spark to the ignition system. Set spark plug gap to 0.6 - 0.7 mm (0.028 - 0.031 inch). Clean spark plug once a week.
9. **Muffler** — Used to reduce noise and emissions.
10. **Fuel Tank** — Holds unleaded gasoline. For additional information refer to engine owner's manual.



## INSPECTION (ENGINE)

### CAUTION



DO NOT attempt to operate the pump until the Safety Information, General Information and Inspection sections of this manual have been read and thoroughly understood.

### BEFORE STARTING

1. Read safety instructions at the beginning of manual.
2. Clean the pump, removing dirt and dust, particularly the engine cooling air inlet, carburetor and air cleaner.
3. Check the air filter for dirt and dust. If air filter is dirty, replace air filter with a new one as required.
4. Check carburetor for external dirt and dust. Clean with dry compressed air.
5. Check fastening nuts and bolts for tightness.

### Engine Oil Check

1. To check the engine oil level, place the pump on secure level ground with the engine stopped.
2. Remove the filler dipstick from the engine oil filler hole (See Figure 5) and wipe clean.

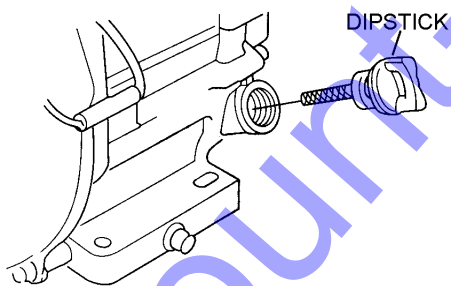

Figure 5. Engine Oil Dipstick (Removal)

3. Insert and remove the dipstick without screwing it into the filler neck. Check the oil level shown on the dipstick.
4. If the oil level is low (See Figure 6), fill to the edge of the oil filler hole with the recommended oil type (Table 5). Maximum oil capacity is 1.16 quarts (1.1 liters).

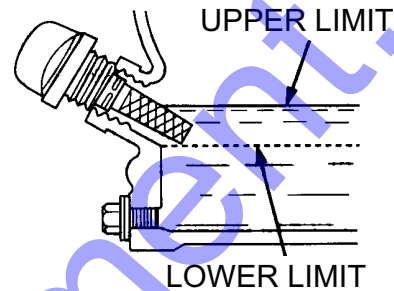

Figure 6. Engine Oil Dipstick (Oil Level)

Table 5. Oil Type

Season	Temperature	Oil Type
Summer	25°C or Higher	SAE 10W-30
Spring/Fall	25°C~10°C	SAE 10W-30/20
Winter	0°C or Lower	SAE 10W-10

### DANGER



Motor fuels are highly flammable and can be dangerous if mishandled. **DO NOT** smoke while refueling. **DO NOT** attempt to refuel the pump if the engine is **hot!** or running.

### Fuel Check

1. Remove the gasoline cap located on top of fuel tank.
2. Visually inspect to see if the fuel level is low. If fuel is low, replenish with unleaded fuel.
3. When refueling, be sure to use a strainer for filtration. **DO NOT** top-off fuel. Wipe up any spilled fuel **immediately!**



1. Place pump as near to water as possible, on a firm flat, level surface.
2. To prime pump, remove fill cap (See Figure 3) and fill pump casing with water. If the pump casing is not filled with water before starting, it will not begin pumping.
3. Attach suction and discharge hoses to the pump. Check that all hoses are **securely** attached to the pump. Make certain suction hose (See Figure 3) does not have any air leakage. Tighten hose clamps and couplings as required.
4. It is recommended that 2 clamps be used when securing the suction hose to the inlet side (suction) of the pump.
5. Remember suction hoses must be **rigid** enough not to collapse when the pump is in operation.
6. Check that the **discharge** hose (See Figure 3) is not restricted. Place hose so that it lays as straight as it is possible on the ground. Remove any twists or sharp bends from hose which may block the flow of water.

### NOTICE

Suction and discharge hoses are available from Multiquip. Contact your nearest dealer for more information.

7. The discharge hose is usually a **collapsible** (thin-walled) hose, however if a thin-walled discharge hose is not available, a rigid suction hose can be substituted in its place.
8. Make sure the **suction strainer** (See Figure 3) is clean and securely attached to the water end of the suction hose. The strainer is designed to protect the pump by preventing large objects from being pulled in to the pump.

### CAUTION

The strainer should be positioned so it will remain completely **under water**. Running the pump with the strainer above water for long periods can damage the pump.

# OPERATION

## CAUTION

**DO NOT** attempt to start the engine unless the pump has previously been primed with water. Severe pump damage will occur if pump has not been primed.

### STARTING THE ENGINE

1. Place the engine fuel valve lever (See Figure 7) to the **ON** position.

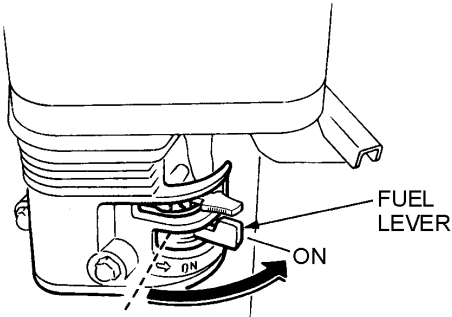

**Figure 7. Engine Fuel Valve Lever (ON Position)**

2. Move the throttle lever (See Figure 8) away from the slow position, about 1/3 of the way toward the fast position.

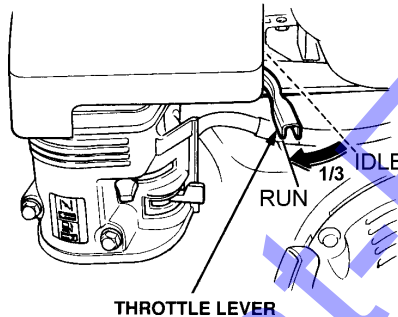

**Figure 8. Throttle Lever (1/3 Start Position)**

3. Place the choke lever (See Figure 9) in the **CLOSED** position if starting a cold engine.

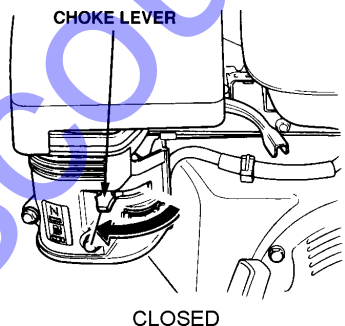

**Figure 9. Engine Choke Lever (Closed)**

4. Place the choke lever (See Figure 10) in the **OPEN** position if starting a warm engine or the temperature is warm.

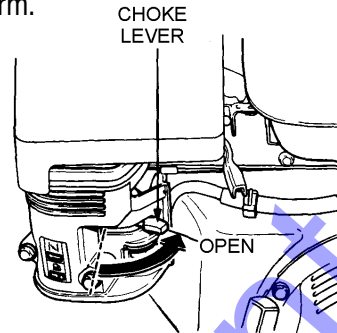

**Figure 10. Engine Choke Lever (Open)**

5. Place the engine **ON/OFF** switch (See Figure 11) in the **ON** position.

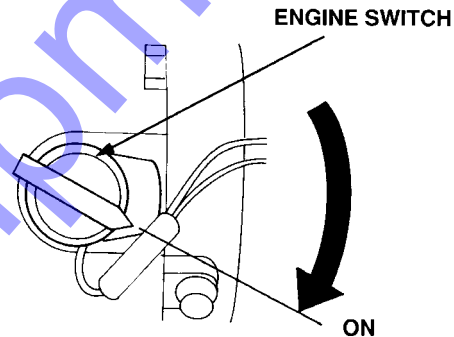

**Figure 11. Engine ON/OFF Switch (ON Position)**

6. Grasp the starter grip (See Figure 12) and slowly pull it out. The resistance becomes the hardest at a certain position, corresponding to the compression point. Pull the starter grip briskly and smoothly for starting.

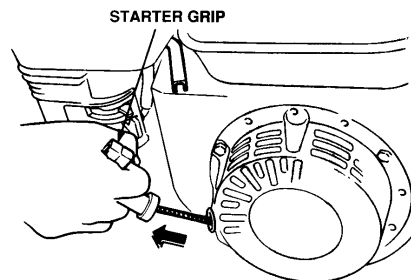

**Figure 12. Starter Grip**

7. If the engine has started and the choke lever was moved to the **CLOSED** position to start the engine, gradually move the choke lever to the **OPEN** position (Figure 13) as the engine warms up. If the engine has not started repeat steps 1 through 6.

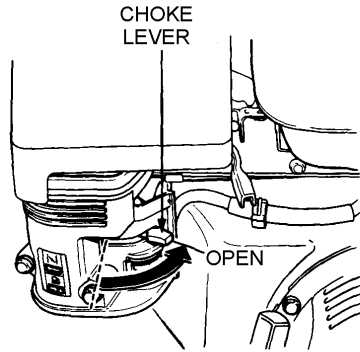

**Figure 13. Choke Lever (Open)**

8. Before the pump is placed in to operation, run the engine for several minutes. Check for fuel leaks, and noises that would associate with a lose component.
9. To begin pumping, place the throttle lever (See Figure 13) in the **RUN** position. If water is not flowing out of the discharge port, turn off the engine and check for and clear any obstructions within the suction hose.

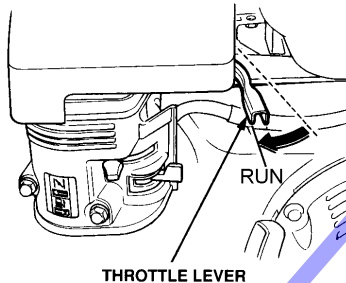

**Figure 14. Throttle Lever (Run)**

## WARNING

Water must always be flowing through the pump casing while the engine is running. Loss of flow may be the result of a loss of prime, restricted water flow or a dead-head situation. Please note that in such a condition, water in the pump can reach temperatures of 150-200°F in 15 to 20 minutes. This can cause serious burns if this hot water comes into contact with unprotected skin.

Before touching or opening the fill plug or drain plug, first turn off the engine and allow the pump casing to cool to the touch, and then open the pump carefully. Be cautious of any built up water pressure.

## CAUTION

**ALWAYS** run engine at **full speed** while pumping.

## STOPPING THE ENGINE

### Normal Shutdown

1. Move the throttle lever to the **IDLE** position (See Figure 14) and run the engine for three minutes at low speed.

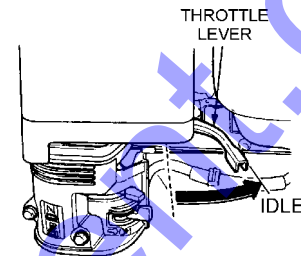

**Figure 15. Throttle Lever (Idle)**

2. After the engine cools, turn the engine **ON/OFF** switch to the **OFF** position (See Figure 15).

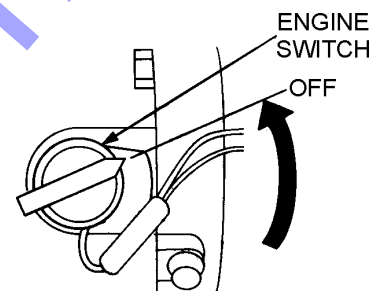

**Figure 16. Engine ON/OFF Switch (OFF)**

3. Place the fuel shut-off lever (See Figure 16) in the **OFF** position

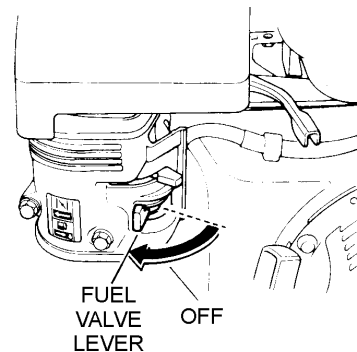

**Figure 17. Fuel Valve Lever (OFF)**

### Emergency Shutdown

1. Move the throttle lever quickly to the **IDLE** position, and place the engine **ON/OFF** switch in the **OFF** position.

# MAINTENANCE (PUMP)

## PUMP VACUUM TEST

### CAUTION

**DO NOT** attempt to start the engine unless the pump has previously been **primed** with water. Severe pump damage will occur if pump has not been primed.

To perform the pump vacuum test do the following:

1. Remove the pump fill cap (See Figure 3), and fill the pump with water.
2. Start the engine as outlined in the initial start-up section, and wait for the pump to begin pumping.
3. As shown in Figure 18, place a water hose inside the discharge opening of the pump, and turn on the water. This flow of water into the discharge opening will **prevent** the pump from running dry.
4. Place the Pump Vacuum Tester (P/N 7000030) over the pump suction (inlet) opening (See Figure 18) with the vacuum gauge facing upwards. It may be necessary to apply a small amount of water around the rubber seal of the vacuum tester to make a good suction fit.
5. Check and make sure that there are no air leaks between the vacuum tester and the inlet port on the pump. If air leaks are present reseal vacuum tester.
6. Run the pump for a few minutes while monitoring the vacuum gauge. If the gauge indicates a reading between -25 and -20 in. Hg. (inches of mercury) then it can be assumed that the pump is working correctly.

### NOTICE

25 in. Hg (inches of mercury) translates into 25 feet of lift at **sea level**.

7. If the vacuum tester gauge indicates a reading below -20 in. Hg, it can then be assumed that the pump is not functioning correctly, and corrective action needs to be taken.
8. To test the flapper valve, shutdown the engine. The vacuum tester should remain attached to the pump suction inlet port by vacuum. This indicates the pump's flapper valve is seating properly to hold water in the suction hose when the engine is stopped. This prevents backflow and allows for faster priming when the engine is restarted.

## ADJUSTING IMPELLER CLEARANCE

1. If it is necessary to replace impeller or volute, be sure clearance between impeller and volute is adjusted
2. The impeller should be as close to the volute as possible without rubbing against it. Clearance is adjusted by adding or removing shims from behind the impeller.
3. Check clearance between impeller and insert by slowly pulling starter rope to turn impeller.

### NOTICE

It is important not to remove too many shims or the clearance between the impeller and volute will become **too wide** and pump performance will be reduced. Remember as the impeller wear down, additional shims may be required to maintain the clearance between the impeller and insert.

4. Check the impeller every six months for wear, and for clearance between the impeller face and the volute. Also check the shaft seal for wear, as well as the shaft sleeve.

## PUMP CLEANING

After pumping water containing large amounts of dirt and debris, perform the following:

1. Remove the drain plug from the pump housing (Figure 3) and drain any water left in the pump.
2. Loosen the two locking hand knobs (turn counterclockwise) and remove clean-out cover.
3. Clean and remove dirt, debris from pump casing. Inspect impeller and volute for wear. Replace any damaged or worn parts.

### CAUTION

The impeller may develop sharp edges. Use extreme care when cleaning around the impeller to prevent being cut..

**CAUTION**  
DO NOT RUN PUMP  
WITHOUT WATER.

PLACE VACUUM TESTER  
OVER PUMP SUCTION PORT

DISCHARGE  
PORT

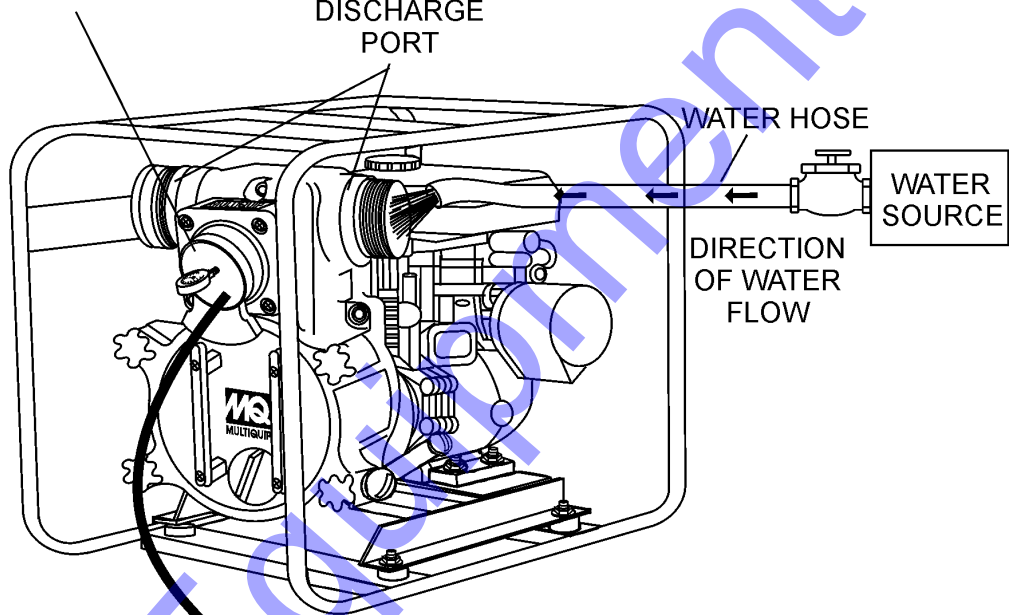

ACCEPTABLE READING  
SHOULD BE BETWEEN  
-25 AND -20 IN. HG

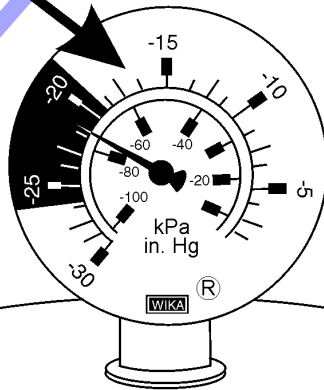

25 IN. HG. TRANSLATES  
INTO 25 FEET OF LIFT  
AT SEA LEVEL.

PUMP VACUUM  
TESTER

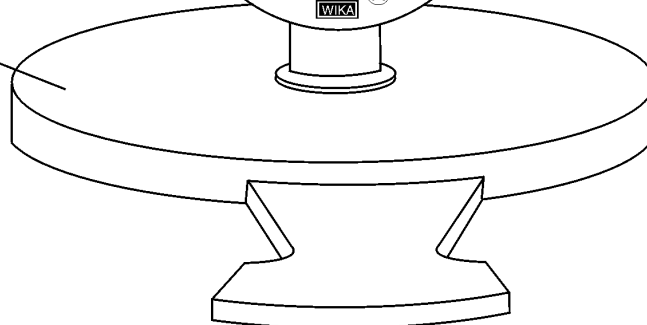

**Figure 18. Pump Vacuum Tester**

# MAINTENANCE (ENGINE)

## ENGINE MAINTENANCE

Perform engine maintenance procedures as referenced by Table 6 below:

Table 6. Engine Maintenance Schedule								
Description (3)	Operation	Before	First Month or 10 hrs	Every 3 Months or 25 hrs	Every 6 Months or 50 hrs	Every Year or 100 hrs	Every 2 Years or 200 hrs	
Engine Oil	CHECK	X						
	CHANGE		X					
Air Cleaner	CHECK	X						
	CHANGE			X (1)				
All Nuts and Bolts	Re-tighten If Necessary	X						
Spark Plug	CHECK-CLEAN				X			
	REPLACE						X	
Cooling Fins	CHECK				X			
Spark Arrester	CLEAN					X		
Fuel Tank	CLEAN					X		
Fuel Filter	CHECK					X		
Idle Speed	CHECK-ADJUST					X (2)		
Valve Clearance	CHECK-ADJUST						X (2)	
Fuel lines	CHECK		Every 2 years (replace if necessary) (2)					

1. Service more frequently when used in **DUSTY** areas.
2. These items should be serviced by your service dealer, unless you have the proper tools and are mechanically proficient. Refer to the HONDA shop Manual for service procedures.
3. For commercial use, log hours of operation to determine proper maintenance intervals.

### NOTICE

Refer to manufacturer engine manual for specific servicing instructions.



# MAINTENANCE (ENGINE)

## DAILY

1. Thoroughly remove dirt and oil from the engine and control area. Clean or replace the air cleaner elements as necessary. Check and retighten all fasteners as necessary. Check the spring box and bellows for oil leaks. Repair or replace as needed.

## WEEKLY

1. Remove the fuel filter cap and clean the inside of the fuel tank.
2. Remove or clean the filter at the bottom of the tank.
3. Remove and clean the spark plug (See Figure 19), then adjust the spark gap to 0.028~0.031 inch (0.6~0.7 mm). This unit has electronic ignition, which requires no adjustments.

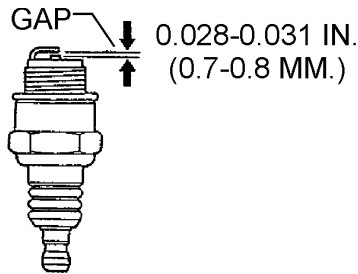

Figure 19. Spark Plug Gap

## ENGINE OIL

1. Drain the engine oil when the oil is **warm** as shown in Figure 20.
2. Remove the oil drain bolt and sealing washer and allow the oil to drain into a suitable container.
3. Replace engine oil with recommended type oil as listed in Table 5. Engine oil capacity is 1.16 quarts (1.1 liters). **DO NOT** over fill.
4. Install drain bolt with sealing washer and tighten securely.

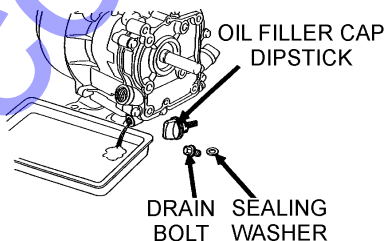

Figure 20. Engine Oil (Draining)

## **DANGER**



**DO NOT** use gasoline as a cleaning solvent, because that would create a risk of fire or explosion.

## ENGINE AIR CLEANER

1. Remove the air cleaner cover and foam filter element as shown in Figure 21.
2. Tap the paper filter element (See Figure 21) several times on a hard surface to remove dirt, or blow compressed air [not exceeding 30 psi (207 kPa, 2.1 kgf/cm<sup>2</sup>)] through the filter element from the air cleaner case side. **NEVER** brush off dirt. Brushing will force dirt into the fibers. Replace the paper filter element if it is excessively dirty.
3. Clean foam element in warm, soapy water or non-flammable solvent. Rinse and dry thoroughly. Dip the element in clean engine oil and completely squeeze out the excess oil from the element before installing.

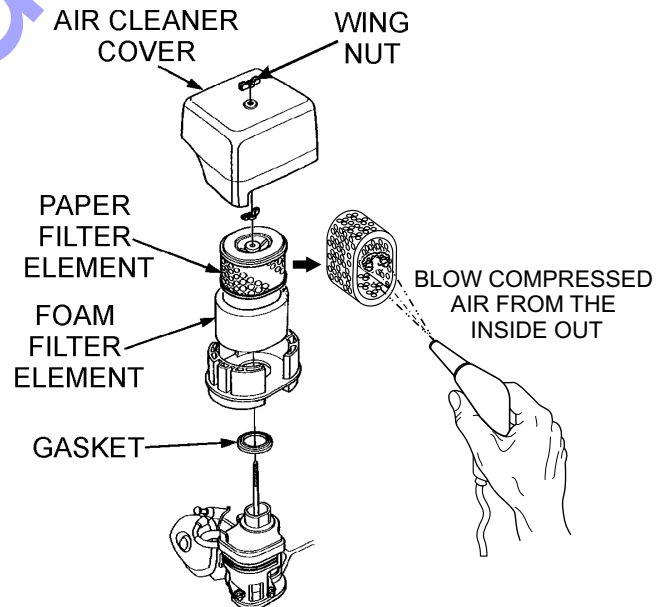

Figure 21. Engine Air Cleaner



## MAINTENANCE (ENGINE)

### SPARK ARRESTER CLEANING

Clean the spark arrester every 6 months or 100 hours.

1. Remove the 4 mm screw (3) from the exhaust deflector, then remove the deflector. See Figure 22.
2. Remove the 5 mm screw (4) from the muffler protector, then remove the muffler protector.
3. Remove the 4 mm screw from the spark arrester, then remove the spark arrester.

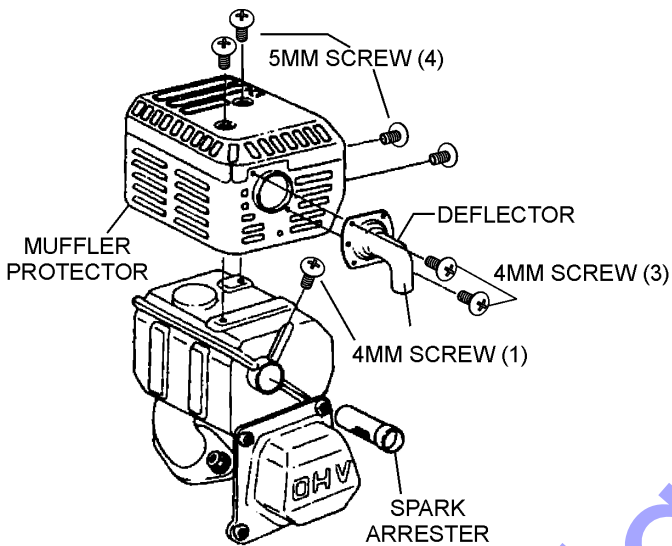

Figure 22. Spark Arrester Removal

4. Carefully remove carbon deposits from the spark arrester screen (Figure 23) with a wire brush.

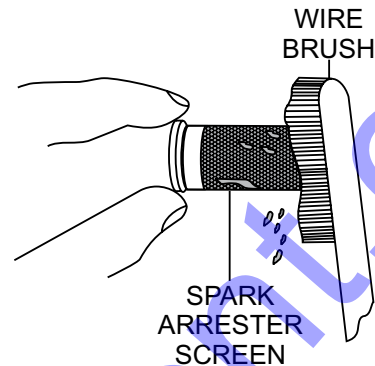

Figure 23. Cleaning The Spark Arrester

5. If the spark arrester is damaged and has breaks or holes, replace with a new one.
6. Reinstall the spark arrester and muffler protector in reverse order of disassembly.

### PUMP STORAGE

For storage of the pump for over 30 days, the following is required:

- Drain the fuel tank completely.
- Run the engine until the fuel is completely consumed.
- Completely drain used oil from the engine crankcase and fill with fresh clean oil, then follow the procedures described in the engine manual for engine storage.
- Remove the drain plug from the pump and drain out any water from left in the housing.
- Remove the pump cover and clean inside of pump housing. Coat inside of pump housing with a light film of oil to reduce corrosion. A spray can of oil works well for this application.
- Cover suction and discharge ports with duct tape to prevent any foreign matter from falling into pump.
- Cover pump and engine with plastic covering or equivalent and store in a clean, dry place.
- To protect the water cooled-seals, place one-half pint of lubricating oil (new or used) through the discharge opening on the pump and crank the engine several times. This will prevent excessive corrosion and also keep the mechanical seal lubricated.

## TROUBLESHOOTING (ENGINE)

<b>Table 7. Engine Troubleshooting</b>		
<b>Symptom</b>	<b>Possible Problem</b>	<b>Solution</b>
<b>Difficult to start</b>		
Fuel is available but spark plug will not ignite. (Power available at high tension cable).	Ignition plug being bridge?	Check ignition system.
	Carbon deposit at ignition?	Clean or replace ignition.
	Short circuit due to defective insulators?	Replace insulators.
	Improper spark gap?	Set spark plug gap to the correct gap.
Fuel is available but spark plug will not ignite. (Power <b>NOT</b> available at high tension cable).	Short circuit at stop switch?	Check stop switch circuit. Replace stop switch if defective.
	Ignition coil defective?	Replace ignition coil.
Fuel is available and spark plug ignites (compression <b>normal</b> ).	Muffler clogged with carbon deposits?	Clean or replace muffler.
	Mixed fuel quality is inadequate?	Check fuel to oil mixture.
	Fuel in use inadequate (water, dust)?	Flush fuel system and replace with fresh fuel.
	Air Cleaner clogged?	Clean or replace air cleaner.
Fuel is available and spark plug ignites (compression <b>low</b> ).	Defective cylinder head gasket?	Tighten cylinder head bolts or replace head gasket.
	Cylinder worn?	Replace cylinder.
	Spark plug loose?	Tighten spark plug.
<b>Operation not satisfactory</b>		
Not enough power available (compression normal, no miss-firing).	Air cleaner clogged?	Clean or replace air cleaner.
	Air in fuel line?	Bleed (remove air) from fuel line.
	Fuel level in carburetor float chamber improper?	Adjust carburetor float.
	Carbon deposits in cylinder?	Clean or replace cylinder.
Not enough power available (compression normal, miss-firing).	Ignition coil defective?	Flush fuel system and replace with fresh fuel.
	Ignition plug often shorts?	Replace ignition wires, clean ignition.
	Fuel in use inadequate (water, dust)?	Flush fuel system and replace with fresh fuel.
Engine overheats.	Excessive carbon deposition in combustion chamber?	Clean or replace crankcase.
	Exhaust or muffler clogged with carbon.	Clean or replace muffler.
	Spark plug heat value incorrect?	Replace spark plug with correct type spark plug.

# TROUBLESHOOTING (ENGINE/PUMP)

**Table 7. Engine Troubleshooting**

Symptom	Possible Problem	Solution
<b>Operation not satisfactory</b>		
Rotational speed fluctuates.	Governor adjustment improper?	Adjust governor to correct lever.
	Governor spring defective?	Clean or replace ignition.
	Fuel flow erratic?	Check fuel line.
	Air taken in through suction line?	Check suction line.
Recoil starter not working properly.	Dust in rotating part?	Clean recoil starter assembly.
	Spring failure?	Replace spiral spring.

**Table 8. Pump Troubleshooting**

Symptom	Possible Problem	Solution
Pump does not take on water.	Not enough priming water in the housing?	Add water.
	Engine speed too low?	Increase throttle.
	Strainer plugged?	Clean strainer.
	Suction hose damaged?	Replace or repair hose, and clamps.
	Air leak at suction port?	Check that fittings are tight and properly sealed.
	Pump is located too high above water line?	Move pump closer to water.
	Debris collecting in pump housing?	Clean pump housing.
	Too much distance between impeller and volute.	Adjust clearance by adding shims or replace impeller. Min. .006" - Max. .020".
	Water leaking out weep hole between pump and engine?	Check condition of mechanical seal and gaskets, between pump end and engine housing.
Pump takes in water, little or no discharge.	Engine speed too low?	Increase throttle speed.
	Suction strainer partially plugged?	Clean strainer.
	Impeller/Volute worn?	Adjust clearance by adding shims or replace impeller/volute.
Suction hose leaks at inlet.	Fittings/clamps are not sealed properly?	Tighten, replace or add clamp. (Keep extra seals on pump).
	Hose diameter is too large?	Use smaller diameter hose or replace hose.
Discharge does not stay on coupling.	Pressure too high?	Check pressure, add additional clamp.
	Hose kinked or end blocked?	Check hose.
Impeller does not turn: pump is hard to start.	Impeller jammed or blocked?	Open pump cover and clean dirt and debris from inside housing.
	Impeller and volute binding?	Adjust clearance by removing shim from behind impeller.
	Defective engine?	See Engine Owner's Manual.

# EXPLANATION OF CODE IN REMARKS COLUMN

The following section explains the different symbols and remarks used in the Parts section of this manual. Use the help numbers found on the back page of the manual if there are any questions.

**NOTICE**

The contents and part numbers listed in the parts section are subject to change **without notice**. Multiquip does not guarantee the availability of the parts listed.

## SAMPLE PARTS LIST

NO.	PART NO.	PART NAME	QTY.	REMARKS
1	12345	BOLT .....	1	INCLUDES ITEMS W/%
2%		WASHER, 1/4 IN. ....		NOT SOLD SEPARATELY
2%	12347	WASHER, 3/8 IN. ...1		MQ-45T ONLY
3	12348	HOSE .....	A/R	MAKE LOCALLY
4	12349	BEARING .....	1	S/N 2345B AND ABOVE

### NO. Column

**Unique Symbols** — All items with same unique symbol (@, #, +, %, or >) in the number column belong to the same assembly or kit, which is indicated by a note in the “Remarks” column.

**Duplicate Item Numbers** — Duplicate numbers indicate multiple part numbers, which are in effect for the same general item, such as different size saw blade guards in use or a part that has been updated on newer versions of the same machine.

**NOTICE**

When ordering a part that has more than one item number listed, check the remarks column for help in determining the proper part to order.

### PART NO. Column

**Numbers Used** — Part numbers can be indicated by a number, a blank entry, or TBD.

TBD (To Be Determined) is generally used to show a part that has not been assigned a formal part number at the time of publication.

◆ A blank entry generally indicates that the item is not sold separately or is not sold by Multiquip. Other entries will be clarified in the “Remarks” Column.

### QTY. Column

**Numbers Used** — Item quantity can be indicated by a number, a blank entry, or A/R.

A/R (As Required) is generally used for hoses or other parts that are sold in bulk and cut to length.

A blank entry generally indicates that the item is not sold separately. Other entries will be clarified in the “Remarks” Column.

### REMARKS Column

Some of the most common notes found in the “Remarks” Column are listed below. Other additional notes needed to describe the item can also be shown.

**Assembly/Kit** — All items on the parts list with the same unique symbol will be included when this item is purchased.

Indicated by:

“INCLUDES ITEMS W/(unique symbol)”

**Serial Number Break** — Used to list an effective serial number range where a particular part is used.

Indicated by:

“S/N XXXXX AND BELOW”

“S/N XXXX AND ABOVE”

“S/N XXXX TO S/N XXX”

**Specific Model Number Use** — Indicates that the part is used only with the specific model number or model number variant listed. It can also be used to show a part is NOT used on a specific model or model number variant.

Indicated by:

“XXXXX ONLY”

“NOT USED ON XXXX”

**“Make/Obtain Locally”** — Indicates that the part can be purchased at any hardware shop or made out of available items. Examples include battery cables, shims, and certain washers and nuts.

**“Not Sold Separately”** — Indicates that an item cannot be purchased as a separate item and is either part of an assembly/kit that can be purchased, or is not available for sale through Multiquip.

## SUGGESTED SPARE PARTS

### QP4TH TRASH PUMP WITH HONDA GX340K1QA2/GX340U1QA2/GX240UT2QA2 ENGINES

1 to 3 units

Qty.	P/N	Description
1.....	1466040030.....	IMPELLER
1.....	0811885433.....	MECHANICAL SEAL SLEEVE
2.....	0803442930.....	MECHANICAL SEAL
1.....	1401350350.....	CHECK VALVE
4.....	0631211159.....	DRAIN CAP
4.....	4660002200002.....	DRAIN COVER KNOB
1.....	0742214100.....	STEEL STRAINER
5.....	17210ZE3505.....	ELEMENT, AIR CLEANER, GX340K1QA2
5.....	17210ZE3010.....	ELEMENT, AIR CLEANER, GX340U1QA2/GX240UT2QA2
5.....	9807956846.....	SPARK PLUG, GX340K1QA2
5.....	9807955846.....	SPARK PLUG, GX340U1QA2/GX240UT2QA2
1.....	17620ZH7023.....	CAP, FUEL TANK, GX340K1QA2
1.....	17620Z4H020.....	CAP, FUEL TANK , GX340U1QA2/GX240UT2QA2
2.....	17672ZE2W01.....	FILTER, FUEL, GX340K1QA2
2.....	17672Z4H020.....	FILTER, FUEL, GX340U1QA2/GX240UT2QA2
1.....	28462ZE3W01.....	ROPE, RECOIL STARTER

#### NOTICE

Part numbers on this Suggested Spare Parts list may supersede/replace the part numbers shown in the following parts lists.

# PUMP ASSEMBLY

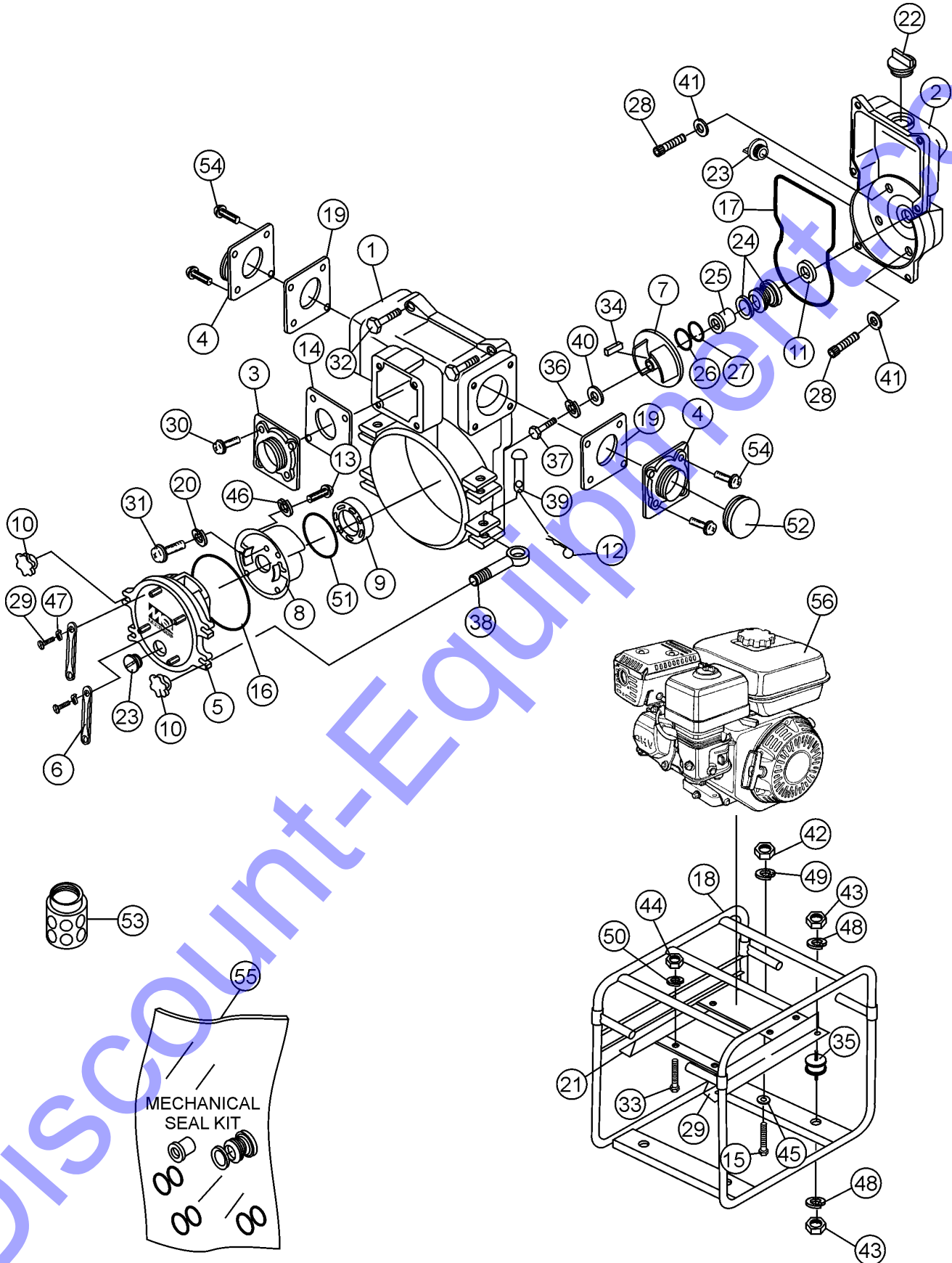



## PUMP ASSEMBLY

<u>NO.</u>	<u>PART NO.</u>	<u>PART NAME</u>	<u>QTY.</u>	<u>REMARKS</u>
1	14660600100002	CASING	1	
2	14660600200002	CASING COVER.....	1	OCTOBER 2007 AND BELOW
2	14660600210002	CASING COVER.....	1	NOVEMBER 2007 AND ABOVE
3	14660000900002	SUCTION COVER, NPT 4"	1	
4	14660000900002	DELIVERY COVER, NPT 4"	2	
5	14660601700002	DRAIN COVER	1	
6	12471002500002	DRAIN COVER SET HANDLE	2	
7	1466040031ASSY	IMPELLER ASSEMBLY	1	
8	1466000130	VOLUTE CASING	1	
9	1466040700	WEAR PLATE	1	
10	14660002200002	DRAIN SET HANDLE	4	
11*	0482200240	O-RING (MECHANICAL SEAL SLEEVE)	2	
12	0641400430	SPLIT PIN	4	
13	0131190820	CAP SCREW, M8X20 (VOLUTE CASING)	3	
14	1401350350	CHECK VALVE	1	
15	0105051045	BOLT, M10X45 (ENGINE)	4	
16*	0483602750	O-RING (DRAIN COVER)	1	
17	1466330460	O-RING (CASING)	1	
18	1466214010P002	BASE	1	
19	1401330360	DELIVERY COVER PACKING	2	
20	0451290080	WASHER, LOCK M8 ( WEAR PLATE )	3	
21	14662140210014	ENGINE BASE.....	1	REPLACES 14662140200014
22	0631211159	FLOODING CAP, PF1 1/2"	1	
23	0631211159	DRAIN CAP, PF1 1/2"	2	
24*	0803442930	MECHANICAL SEAL	1	
25*	0811885433	MECHANICAL SEAL SLEEVE	1	
26*	0852834525	ADJUST LINER, F45XF25.4 T0.3	1	
27*	0852854525	ADJUST LINER, F45XF25.4 T0.5	1	
28	0131290665	CAP SCREW, 3/8-16UNCx65 (CASING CVR SET BOLT)	4	
29	0141050825	SCREW, M8x25 (DRAIN CUVER SET HANDLE)	4	
30	0131151225	CAP SCREW, M12x25 (SUCTION COVER	4	
31	0131190820	CAP SCREW, M8x20 (WEAR PLATE)	3	
32	0131151230	CAP SCREW, M12x30 (CASING)	6	
33	0105051040	BOLT, M10x40 (PUMP)	2	
34	0520040440	KEY, 6.3x40	1	
35	0723302546	CUSHION RUBBER	4	
36	0458220071	WASHER, SEAL (IMPELLER)	1	
37	0107090650	BOLT, 3/8-24UNFX50 (IMPELLER)	1	
38	1466200270	HINGE BOLT, M10x65	4	
39	1466220280	HINGE PIN	4	

# PUMP ASSEMBLY

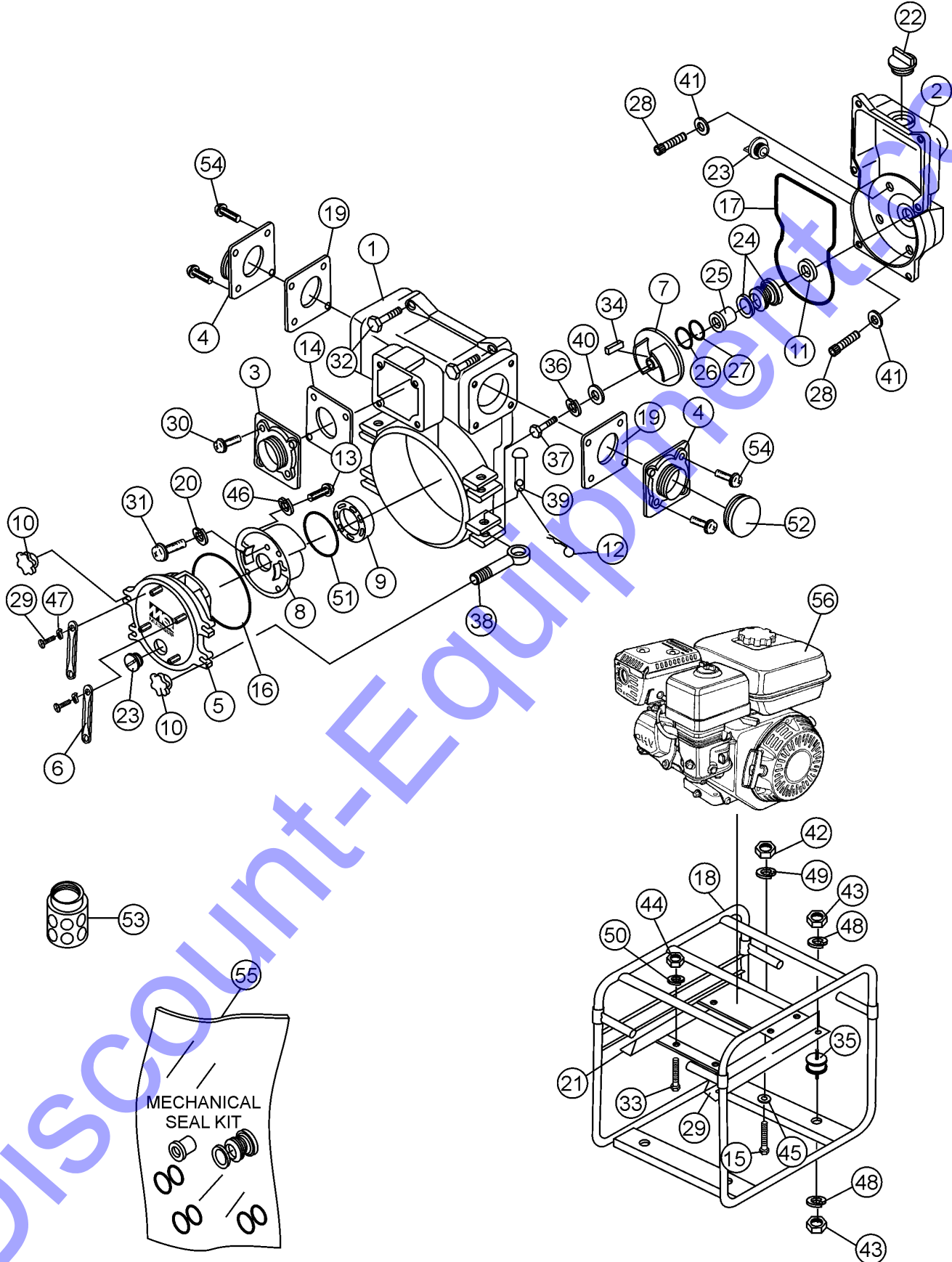

## PUMP ASSEMBLY

<u>NO.</u>	<u>PART NO.</u>	<u>PART NAME</u>	<u>QTY.</u>	<u>REMARKS</u>
40	1466251241	IMPELLER WASHER, 42 X 9.8 X T6.0.....	1.....	REPLACES 43342012400011
41	0458220071	SEAL WASHER, 3/8" (CASING COVER )	4	
42	0205450100	NUT, M10 (ENGINE)	4	
43	0205450100	NUT, M10 (CUSHION RUBBER)	8	
44	0205450100	NUT, M10 (PUMP)	4	
45	0401450100	WASHER, M10 (ENGINE)	4	
46	0451290080	WASHER, SPRING M8 (VOLUTE CASING)	3	
47	0451250080	WASHER, SPRING M8 (DRAIN COVER SET HANDLE)	4	
48	0451250100	WASHER, SPRING M10 (CUSHION RUBBER)	8	
49	0451250100	WASHER, SPRING M10 (ENGINE)	4	
50	0451250100	WASHER, SPRING M10 (PUMP)	2	
51*	0481572500	O-RING (VOLUTE CASING)	1	
52	1466108050	CAP	1	
53	0742214100	STRAINER	1	
54	0131151220	CAP SCREW, M12x20 (DELIVERY COVER)	8	
55	KIT4TH	KIT, MECHANICAL SEAL, SLEEVE, O-RINGS.....	1.....	INCLUDES ITEMS W/ *
56	GX340K1QA2	ENGINE, HONDA 10.7 HP .....	1.....	S/N 4TH-0249 AND BELOW
56	GX340U1QA2	ENGINE, HONDA 10.7 HP .....	1.....	S/N 4TH-0250 TO 4TH-3304
56	GX340UT2QA2	ENGINE, HONDA 10.7 HP .....	1.....	S/N 4TH-3305 AND ABOVE

# ENGINE SERVICE PARTS

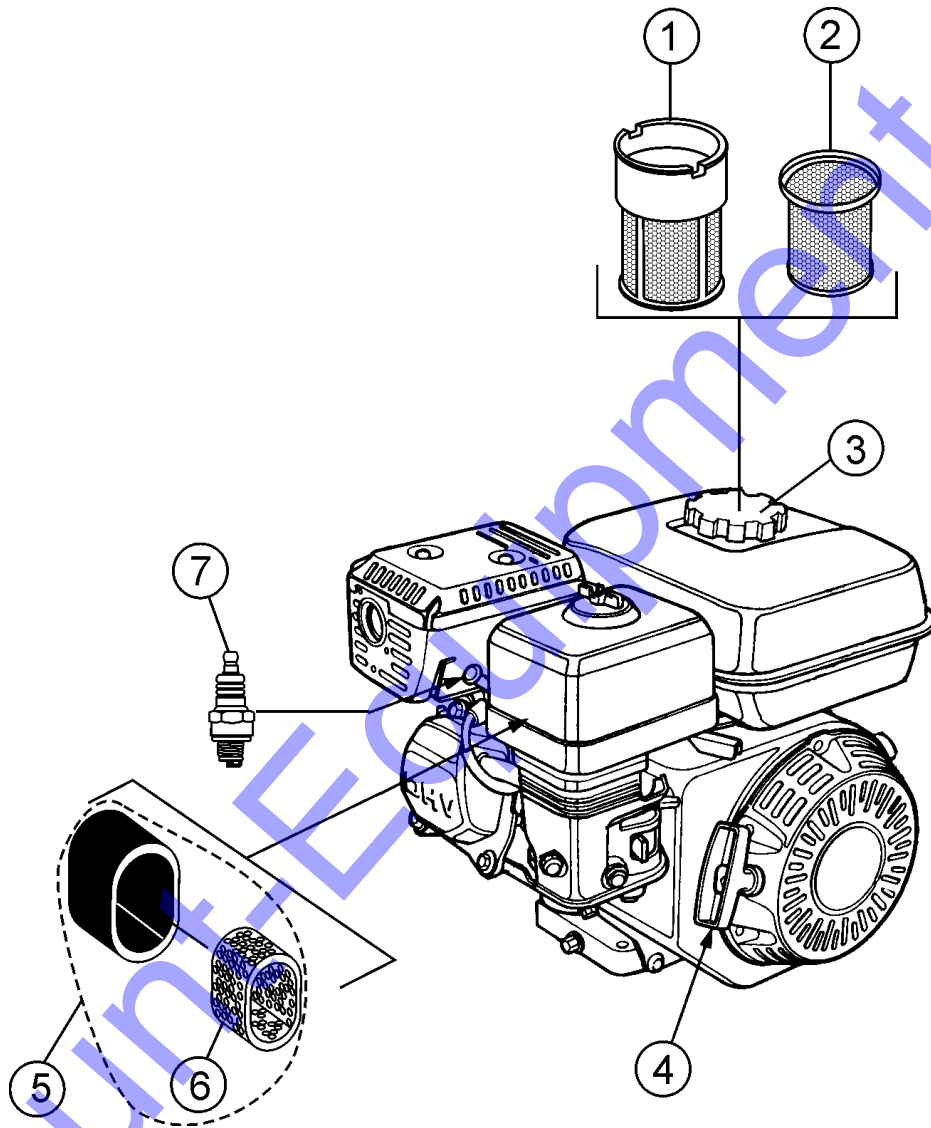

## ENGINE SERVICE PARTS

<u>NO.</u>	<u>PART NO.</u>	<u>PART NAME</u>	<u>QTY.</u>	<u>REMARKS</u>
1	17672ZE2W01	FILTER, FUEL.....	1.....	GX340K1QA2
2	17672Z4H020	FILTER, FUEL.....	1.....	GX340U1QA2/GX240UT2QA2
3	17620ZH7023	CAP, FUEL TANK .....	1.....	GX340K1QA2
3	17620Z4H020	CAP, FUEL TANK.....	1.....	GX340U1QA2/GX240UT2QA2
4	28462ZE3W01	ROPE, RECOIL STARTER	1	
5	17210ZE3505	ELEMENT, AIR CLEANER .....	1.....	GX340K1QA2 INCLUDES ITEM W/ #
5	17210ZE3010	ELEMENT, AIR CLEANER .....	1.....	GX340U1QA2/GX240UT2QA2 INCLUDES ITEM W/ #
6#	17218ZE1507	FILTER, OUTER	1	
7	9807956846	SPARK PLUG .....	1.....	GX340K1QA2
7	9807955846	SPARK PLUG .....	1.....	GX340U1QA2/GX240UT2QA2

# **Discount Equipment**

Discount-Equipment.com is your online resource for commercial and industrial quality parts and equipment sales.

## **Locations:**

Florida (West Palm Beach): [561-964-4949](tel:561-964-4949)

Outside Florida TOLL FREE: [877-690-3101](tel:877-690-3101)

**Need parts?** Check out our website at [www.discount-equipment.com](http://www.discount-equipment.com)

## **Can't find what you need?**

Click on this link: <http://www.discount-equipment.com/category/5443-parts/> and fill out the request form.

Please have the machine model and serial number available in order to help us get you the correct parts. One of our experienced staff members will get back to you with a quote for the right part that your machine needs.

We sell worldwide for the brands: Genie, Terex, JLG, MultiQuip, Mayco, Toro/Stone, Diamond Products, Magnum, Airman, Mustang, Power Blanket, Nifty Lift, Atlas Copco, Chicago Pneumatic, Allmand Brothers, Essick, Miller Spreader, Skyjack, Lull, Skytrak, Tsurumi, Husquyarna/Target, Whiteman-Concrete/Mortar, Stow-Concrete/Mortar, Baldor, Wacker, Sakai, Snorkel, Upright, Mi-T-M, Sullair, Neal, Basic, Dynapac, MBW, Weber, Bartell, Bennar Newman, Haulotte, Ditch Runner, Blaw-Knox, Himoinsa, Best, Buddy, Crown, Edco, Wyco, Bomag, Laymor, Terremite, Barreto, EZ Trench, Takeuchi, Basic, Bil-Jax, Curtis, Gehl, Heli, Honda, ICS/PowerGrit, Puckett, Waldon, ASV, IHI, Partner, Imer, Clipper, MMD, Koshin, Rice, Gorman Rupp, CH&E, Cat Pumps, Comet, General Pump, Giant, AMida, Coleman, NAC, Gradall, Square Shooter, Kent, Stanley, Tamco, Toku, Hatz, Kohler, Robin, Wisconsin, Northrock, Oztec, Toker TK, Rol-Air, Small Line, Wanco, Yanmar