

GENERAL PURPOSE ENGINE

**GX240K1
GX240K1
[PROPANE ENGINE]**

PARTS CATALOGUE

8



GX240K1

FOREWORD INDEX

1

ENGINE GROUP

2

PART NUMBER INDEX

3

PART NAME INDEX

4

Instruction for use of parts catalogue

- **This parts catalogue was prepared based on the latest information available as of December 20, 2007.**
- See the parts catalogue news for any revision that is made after December 20, 2007.
- **Always specify the part number when ordering a part.**
- Check the model, type, serial numbers, color, maker, and the size as needed before ordering a part.
- Note that the illustrations (part drawings) can differ from the actual parts in shape. They are given just to help you to refer to the parts.
- **When modifications or additions to this parts catalogue are made, a revised edition will be issued at an appropriate time, with successively progressing revision numbers on the cover. We recommend obtaining such revisions in order to keep your parts catalogue up-to-date at all times. To check whether a parts catalogue revision has been issued, please contact your Honda distributor.**

Initial version issue date **January 10, 1991**
Honda Motor Co., Ltd.

CONTENTS

	Page	Address No.	
● Instruction for use of parts catalogue	1	B 1	1
● How to refer to the part information	2	B 2	
● Part catalogue structure	3	B 3	
● When the parts were revised	4	B 4	
● Abbreviations used in the parts catalogue	4	B 4	
● How to check the part block and serial numbers	5	B 5	
● Models, parts catalogue codes and applicable serial numbers	6	B 6	
● Features of each type	15	B15	
● Fuel hose, general purpose hoses and vinyl hose	34	D 2	
● FLAT RATE SERVICE TIME	35	D 3	
● Illustrated index	40	D 8	
● ENGINE GROUP	48	E 1	2
● PART NO. INDEX	284	2-G 1	3
● PART NAME INDEX	291	2-H 1	4

How to refer to the part information

A Reference with "Illustrated index"

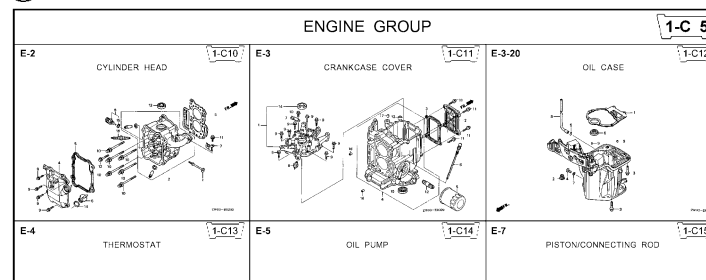

B Reference with "Part number index"

PART NO. INDEX

Part Number	Address	Page	Ref.	Part Number	Address	Page
06000				15212-ZW9-000	1-C14	3C
06316-ZW9-000	1-G9	88	1	15220-ZW9-003	1-C14	3C
11000				15332-ZW9-000	1-E8	55
11300-ZW9-405	1-C11	27	1	15332-ZW9-A30	1-E11	5E
11300-ZW9-406	1-C11	27	1	15400-PF8-004	1-C11	27
11340-ZW9-000	1-C11	27	2	15422-ZW9-000	1-C14	3C
11342-ZW9-000	1-C11	27	3	15473-881-000	1-C14	3C
11381-ZW9-003	1-C12	28	1	15474-ZW9-000	1-C14	3C
				15611-921-000	1-C10	2E
				15655-ZW9-000	1-C11	27
12000				16000		
12000-ZW9-405ZA	1-C11	27	4	16010-ZV4-005	1-D4	3E
12155-ZV4-A00	1-C13	29	1	16011-ZV4-005	1-D4	3E
12166-ZW9-000	1-C10	26	1	16013-ZW9-003	1-D4	3E
12209-GB4-681	1-C16	32	1	16016-ZW9-003	1-D4	3E
12210-ZW9-405ZA	1-C10	26	2	16016-ZW9-721	1-D4	3E
12216-ZE2-300	1-E8	55	1	16023-ZW9-003	1-D4	3E
	1-E11	58	1	16024-ZV4-650	1-D4	3E
				16028-ZV4-650	1-D4	3E

C Reference with "Part name index"

PART NAME INDEX

Part name	Address	Page	Ref.
[A]			
ABSORBER , FUEL	1-E15	62	5
ARMATURE COMP.	1-D11	43	7
ARM COMP. , LINK JOINT	1-G6	85	18
ARM COMP. , SHIFT LINK	1-G6	85	14
ARM COMP. , TILT	1-F15	79	20
ARM , FUEL PUMP ROCKER	1-C16	32	4
ARM , REVERSE LOCK	1-F15	79	18
ARM , SHIFT LINK	1-F11	74	7
ARM , STOPPER	1-D1	33	12
ARM , THROTTLE REMOTE	1-F11	74	6
ARM , VALVE ROCKER	1-C16	32	3
[B]			
BAG , TOOL , 160MM	1-G5	84	10
BAND	1-G6	86	37
BAND B1 , WIRE	1-F6	69	1
BAND , CORD	1-F3	67	18
BAND , TUBE CLIP , 11MM	1-E15	63	20
BAND , TUBE CLIP , 12.5MM	1-E15	63	19

Address No. 1-C10

E-2 CYLINDER HEAD

Block No.

Ref No.

Ref. No.	Part No.	Description	Reqd. QTY						Serial No.	Parts catalogue code
			99D1	99D1	1001	1001	1001	1001		
1	12166-ZW9-000	STOPPER, ENGINE SIDE	2	2	2	2	2	2		
2	12210-ZW9-000ZA	HEAD COMP., CYLINDER	1	1	1	1	1	1		
3	12251-ZW9-003	GASKET, CYLINDER HEAD	1	1	1	1	1	1		
4	12310-ZW9-000	COVER COMP., HEAD	1	1	1	1	1	1		
5	12312-ZW9-000	PACKING, HEAD COVER	1	1	1	1	1	1		
6	15611-921-000	CAP, OIL (NO GAUGE)	1	1	1	1	1	1		
7	16617-ZW9-000	HOLDER, CABLE	1	1	1	1	1	1	SC,SG	
	16617-ZW9-010		1	1	1	1	1	1	1001800 LHC,LHD	
			1	1	1	1	1	1	1001801 LHC,LHD	
8	35675-ZW5-003	SENSOR ASSY., WATER	1	1	1	1	1	1		
9	90003-ZW9-000	BOLT, FLANGE, 6X22	1	4	4	4	4	4		
10	90007-ZW9-003	BOLT, FLANGE, 8X83	6	6	6	6	6	6		
11	90011-ZW9-000	BOLT, FLANGE, 6X14(CT200)	1	1	1	1	1	1		
12	90020-ZW9-000	BOLT, FLANGE, 8X40	2	2	2	2	2	2		
13	91202-KJ9-003	OIL SEAL, 20X32X6	1	1	1	1	1	1		
14	91301-805-000	O-RING, 26X2.7	1	1	1	1	1	1		
15	91307-PK2-005	O-RING, 9.5X1.5(HONDA KIKAKI)	1	1	1	1	1	1		
16	98059-55916	PLUG, SPARK (CR5EH-9)	2	2	2	2	2	2		
	98059-55926	PLUG, SPARK (U16FER9)	2	2	2	2	2	2		

Service item F.R.T.

- O-RING, 26X2.7 0.1
- PLUG, SPARK 0.2
- O-RING, 9.5X1.5 0.2
- SENSOR ASSY., WATER TEMPERATURE 0.3
- COVER COMP., HEAD 1.8
- PACKING, HEAD COVER 2.4
- GASKET, CYLINDER HEAD 2.4
- OIL SEAL, 20X32X6 3.1
- HEAD COMP., CYLINDER 3.1

ZW83-ED200

Page No.

2000.09.20 E

Part catalogue structure

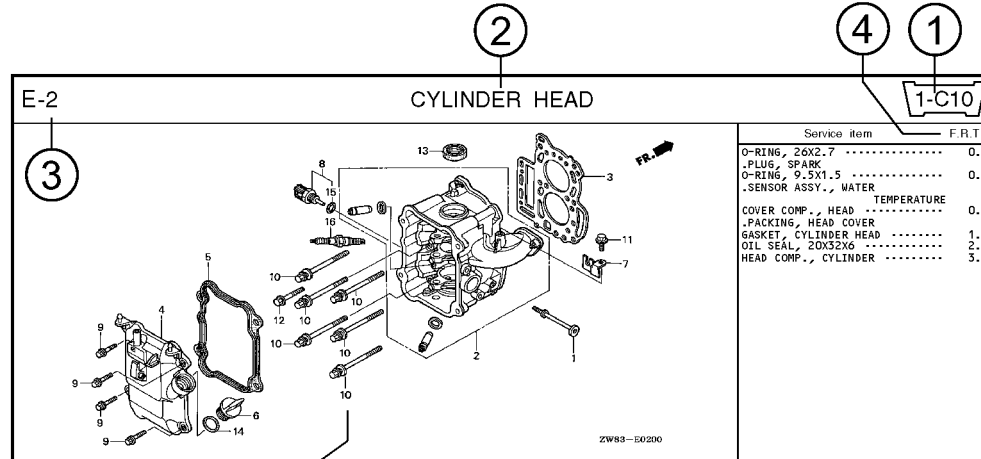

Ref. No.	Part No.	Description	Reqd. QTY						Serial No.	Parts catalogue code
			BF 9/9D1	BFP 9/9D1	BF 10D1	BFP 10D1	BF 10B1	BFP 10B1		
1	12166-ZW9-000	STOPPER, ENGINE SIDE	2	2	2	2	2	2		
2	12210-ZW9-000ZA	HEAD COMP., CYLINDER *NHS* DARK GRAY	1	1	1	1	1	1		
3	12251-ZW9-003	GASKET, CYLINDER HEAD	1	1	1	1	1	1		
4	12310-ZW9-000	COVER COMP., HEAD	1	1	1	1	1	1		
5	12312-ZW9-000	PACKING, HEAD COVER	1	1	1	1	1	1		
6	15611-921-000	CAP, OIL (NO GAUGE)	1	1	1	1	1	1		
7	16617-ZW9-000	HOLDER, CABLE	1	1	1	1	1	1	----- SC,SG	
	16617-ZW9-010		1	1	1	1	1	1	----- 1001800 LHC,LHD	

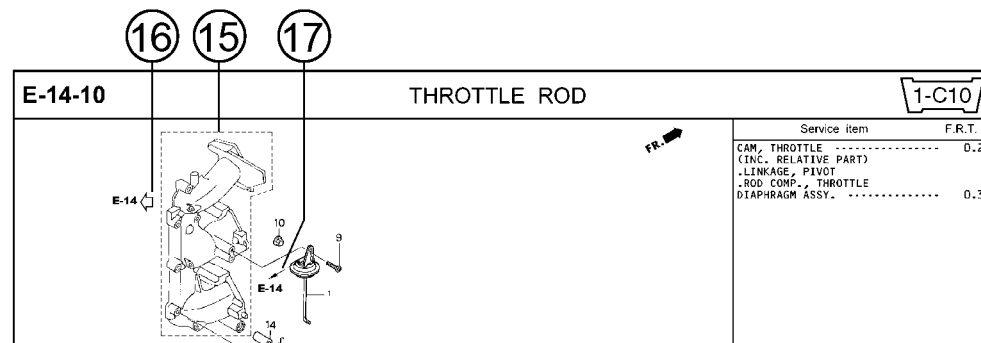

- ① **Address number**
 - Address No. is provided (in place of the page No.) to help you refer to the part with the part No. or part name.
- ② **Block title** ③ **Block number**
- ④ **Service item/Flat rate time**
- ⑤ **Reference number**
 - Title number marked with the parenthesis or parentheses indicates that it continues from the previous page.
- ⑥ **Part number** ⑦ **Honda color code**
- ⑧ **Description**
- ⑨ **Assemblies**
 - Sections framed with broken lines in the exploded view drawings are available as complete assemblies. (Their individual parts can also be obtained.)
- ⑩ **Color description**
- ⑪ **Note**
 - Notes are shown with the parentheses in the part name column.
- ⑫ **Required quantity**
 - Required QTY shown in the parenthesis or parentheses indicates the optional part.
 - Required QTY marked with "N" Indicates the optional part that should be selected as needed.
 - Required QTY indicates the number of the part used in the block.
- ⑬ **Serial number**
- ⑭ **Type**
 - When the type column is blank, it indicates that the part is applicable to all types.
 - As the type of the actual unit may differ from the "parts catalogue, type" please refer to "Models, types and applicable serial numbers" for confirmation.
- ⑮ **[Dotted line]**
 - Parts enclosed within a dotted line [] are covered in a different block.
- ⑯ **[Hollow arrow]**
 - A hollow arrow [] indicates the block No. for the parts enclosed within a dotted line [] .
- ⑰ **[Solid arrow]**
 - A solid arrow [] indicates the block No. the part in question is connected to.

When the parts were revised

Abbreviations used in the parts catalogue

1



Be sure to check the serial number!!



Ref. No.	Part No.	Description	Reqd. QTY						Serial No.
			BF 99D1	BFP 9.9D1	BF 10D1	BFP 10D1	BF 10B1	BFP 10B1	
1	12166-ZW9-000	STOPPER, ENGINE SIDE	2	2	2	2	2	2	
2	12210-ZW9-000ZA	HEAD COMP., CYLINDER *NHS* DARK GRAY	1	1	1	1	1	1	
3	12251-ZW9-003	GASKET, CYLINDER HEAD	1	1	1	1	1	1	
4	12310-ZW9-000	COVER COMP., HEAD	1	1	1	1	1	1	
5	12312-ZW9-000	PACKING, HEAD COVER	1	1	1	1	1	1	
6	15611-921-000	CAP, OIL (NO GAUGE)	1	1	1	1	1	1	
7	16617-ZW9-000	HOLDER, CABLE (###)	1	1	1	1	1	1	SC, SG LHC, LHD LHC, LHD
	16617-ZW9-010	1	1	1	1	1	1	

The number has been used from the initial model without revision.

When shown at the left side, it is applicable to the models of No.1001801 and the subsequent numbers.

When shown at the right side, it is applicable to the models up to No.1001800.

• The parts listed with "###" at the end of the parts name have limited supply period (parts not for sale).

• The following abbreviations are used in the parts name column.

- | | |
|--|-----------------------------|
| A Ampere | FR.Front |
| A.C. Alternating current | IN.Inlet |
| ASSY. Assembly | L (100L) .Link (100 Links) |
| AT. Automatic transmission | L.Left |
| C.D.I. Capacitive discharge ignition | MMMillimeter |
| COMP. ... Complete | MT.Manual Transmission |
| D.C. Direct current | P.T.O.Power take off |
| EX. Exhaust | R.Right |
| G.F.C.I ... Ground fault circuit interruptor | RR.Rear |
| HEX. Hexagonal | STD.Standard |
| H.S.T. Hydrostatic transmission | T (22T) ...Tooth (22 Teeth) |
| | VVolt |
| | WWatt |

How to check the part block and serial numbers

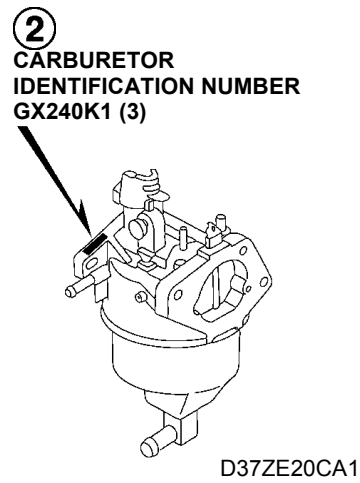
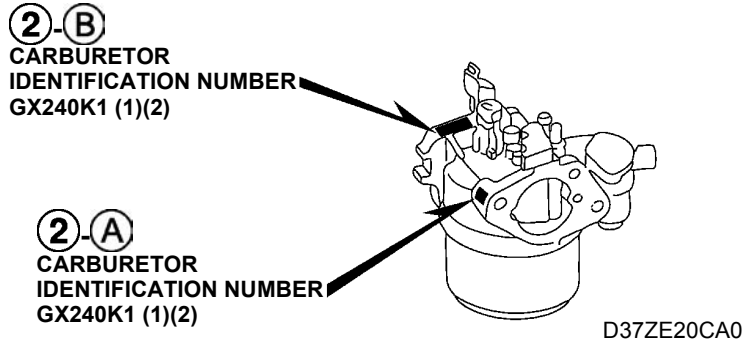
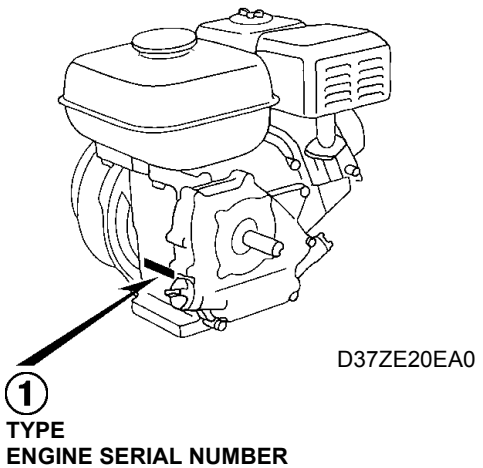
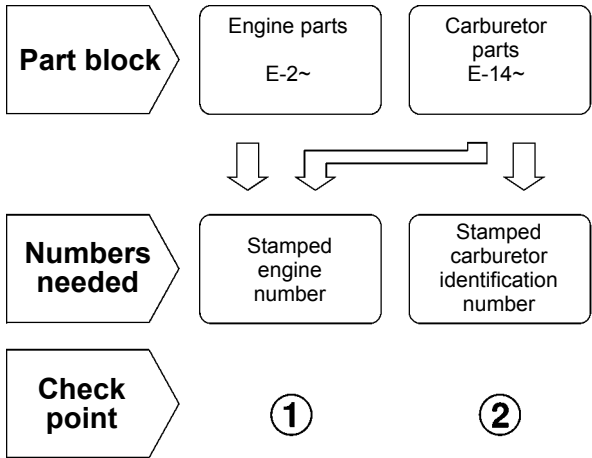

Models, parts catalogue codes and applicable serial numbers

- Models, parts catalogue codes and applicable serial Nos. given in this parts catalogue can be identified as follows.

Model	Type	Parts catalogue type	Applicable engine serial No.	Applicable carburetor identification No.	Model	Type	Parts catalogue type	Applicable engine serial No.	Applicable carburetor identification No.
GX240K1 (1)	EDN	EDN	GC04- 3000001~4399999	BE20B A / B BE72C B	GX240K1 (1)	EDT6	EDT6/A	GC04- 4400001~9999999	BE72C B / C
	EDN2	EDN2		BE72C A / B		ED2	ED2	GC04- 3000001~4399999	BE20B A BE72C A / B
		EDN2/A	GC04- 4400001~9999999	BE72C B / C			ED2/A	GC04- 4400001~9999999	BE72C B / C
	EDS	EDS	GC04- 3000001~4399999	BE20B A / B		ED3	ED3	GC04- 3000001~4399999	BE15G A / B BE70B B / C
	EDS1	EDS1		BE20B A / B BE72C B		ED4	ED4	GC04- 4400001~9999999	BE70B B / C
		EDS1/A	GC04- 4400001~	BE72C B BE72L A			ED4/A	GC04- 4400001~9999999	BE70B B / C
	EDS2	EDS2	GC04- 3000001~4399999	BE72C B		ED5	ED5	GC04- 3000001~4399999	BE15G A / B BE70B B / C
		EDS2/A	GC04- 4400001~9999999	BE72C B / C			ED5/A	GC04- 4400001~	BE70B B / C
	EDS3	EDS3		BE20B A / B BE72C B		EN	EN	GC04- 3000001~4399999	BE15G A / B
	EDS5	EDS5	GC04- 3000001~4399999	BE22C A / B		EN2	EN2		BE72C B
	EDS6	EDS6		BE72C B			EN2/A	GC04- 4400001~9999999	BE72C B / C
		EDS6/A	GC04- 4400001~9999999	BE72C B / C		ES	ES	GC04- 3000001~4399999	BE15G A / B
	EDT1	EDT1	GC04- 3000001~4399999	BE20B A / B BE72C B		ES1	ES1		BE15G B / C
		EDT1/A	GC04- 4400001~	BE72C B BE72L A			ES1/A	GC04- 4400001~	BE15G C
	EDT2	EDT2	GC04- 3000001~4399999	BE72C B		ES2	ES2		
EDT3	EDT3	GC04- 4400001~	BE72L A	ES3	ES3	GC04- 3000001~4399999	BE20B A / B BE72C B		
EDT6	EDT6	GC04- 3000001~4399999	BE72C B		ES3/A	GC04- 4400001~	BE72C B BE72L A		

Model	Type	Parts catalogue type	Applicable engine serial No.	Applicable carburetor identification No.	Model	Type	Parts catalogue type	Applicable engine serial No.	Applicable carburetor identification No.	
GX240K1 (1)	ET	ET	GC04- 3000001~4399999	BE15G A / B	GX240K1 (1)	LDB3	LDB3	GC04- 3000001~4399999	BE15F A / B	
	ETS	ETS				LH	LH		BE15G A / B	
	ETX	ETX				LH	LH/A	GC04- 4400001~	BE70B B / C	
	HA	HA					LHE	LHE	GC04- 3000001~4399999	BE15G A / B
	HAQ	HAQ				LHE4	LHE4	BE70B B / C		
	HA2	HA2					LHE4/A	LHE4/A	GC04- 4400001~9999999	BE70B B / C
		HA2/A	GC04- 4400001~9999999	BE70B B / C						
	HH	HH	GC04- 3000001~4399999	BE15G A / B		GX240K1 (1)	LHZ	LHZ	GC04- 3000001~4399999	BE15G B
	HHQ4	HHQ4	GC04- 4400001~9999999	BE15G A / B			LJ	LJ		BE15G A / B
		HHQ4/A		BE70B B / C				LJ/A	GC04- 4400001~	BE15G B / C
	HTX	HTX	GC04- 3000001~4399999	BE15G A / B			LJG	LJG	GC04- 3000001~4399999	BE15G A / B
	HX	HX	GC04- 4400001~	BE15G A / B				LJG1	LJG/A	GC04- 4400001~
		HX/A		BE70B B / C			LJG1		LJG1	GC04- 3000001~4399999
	HXQ4	HXQ4	GC04- 3000001~4399999	BE15G A / B			LJS	LJS	GC04- 4400001~	BE70B B / C
HXQ4/A		GC04- 4400001~9999999	BE70B B / C	LJS/A						
LD	LD	GC04- 3000001~4399999	BE15F A / B	LK	LK		GC04- 3000001~4399999	BE15G A / B		
LDB1	LDB1			LKS	LKS		GC04- 4400001~			
				LKS/A	LKS/A				BE15G B / C	

1

Model	Type	Parts catalogue type	Applicable engine serial No.	Applicable carburetor identification No.
GX240K1 (1)	LM9	LM9	GC04- 3000001~4399999	BE15G A / B
	LNJ	LNJ		
	LNZ	LNZ		
	LP	LP		
		LP/A	GC04- 4400001~	BE15G B / C
	LSS4	LSS4	GC04- 3000001~4399999	BE16D B
	LSS5	LSS5	GC04- 4400001~9999999	BE15G B
		LSS5/A		BE15G B / C
	LSX	LSX	GC04- 3000001~4399999	BE15G B BE70B B / C
		LSX/A	GC04- 4400001~	BE70B B / C
	LT	LT	GC04- 3000001~4399999	BE15G B
		LT/A	GC04- 4400001~	BE15G B / C
	LW	LW	GC04- 3000001~4399999	BE15G A / B
	LX	LX	GC04- 4400001~	BE15G A / B BE70B B / C
LX/A		BE70B B / C		
LXF	LXF			
LXQ4	LXQ4	GC04- 3000001~4399999	BE15G A / B BE70B B / C	

Model	Type	Parts catalogue type	Applicable engine serial No.	Applicable carburetor identification No.
GX240K1 (1)	LXQ4	LXQ4/A	GC04- 4400001~9999999	BE70B B / C
	LXZ	LXZ	GC04- 3000001~4399999	BE15G A / B
	LX2	LX2	GC04- 4400001~9999999	BE70B A / B / C
		LX2/A		BE70B B / C
	PA	PA	GC04- 3000001~4399999	BE15G A / B
	PAE	PAE		BE70B A / B / C
	PA2	PA2		GC04- 4400001~9999999
		PA2/A	BE70B B / C	
	PMT2	PMT2	GC04- 3000001~4399999	BE70B A / B / C
		PMT2/A	GC04- 4400001~9999999	BE70B B / C
	PX	PX	GC04- 3000001~4399999	BE15G A / B BE70B B / C
		PX/A	GC04- 4400001~	BE70B B / C
	QA	QA	GC04- 3000001~4399999	BE15G A / B
	QAB2	QAB2	GC04- 4400001~9999999	BE70B B / C
		QAB2/A		
	QAE	QAE	GC04- 3000001~4399999	BE15G A / B
	QAE2	QAE2		BE70B A / B / C

Model	Type	Parts catalogue type	Applicable engine serial No.	Applicable carburetor identification No.
GX240K1 (1)	QAE2	QAE2/A	GC04-4400001~9999999	BE70B B / C
	QAG	QAG	GC04-3000001~4399999	
		QAG/A	GC04-4400001~9999999	
	QAG2	QAG2	GC04-3000001~4399999	BE70B A / B / C
		QAG2/A	GC04-4400001~9999999	BE70B B / C
	QAQ	QAQ		BE70A A / B
	QAQ4	QAQ4	GC04-3000001~4399999	BE15G A / B
				BE70B B / C
	QAR2	QAR2		BE70B A / B / C
		QAR2/A	GC04-4400001~9999999	BE70B B / C
	QA2	QA2	GC04-3000001~4399999	BE70B A / B / C
		QA2/A	GC04-4400001~9999999	
	QC12	QC12	GC04-3000001~4399999	BE70B B / C
		QC12/A	GC04-4400001~9999999	
	QD	QD	GC04-3000001~4399999	BE15F A / B
QD/A		GC04-4400001~	BE15F B	
QDA	QDA	GC04-3000001~4399999	BE15G A	
QE	QE	GC04-3000001~4399999	BE15G A / B	

Model	Type	Parts catalogue type	Applicable engine serial No.	Applicable carburetor identification No.
GX240K1 (1)	QE	QE/A	GC04-4400001~9999999	BE15G B / C
	QH	QH	GC04-3000001~4399999	BE15G A / B
		QH/A	GC04-4400001~	BE70B B / C
	QHB2	QHB2	GC04-4400001~9999999	
	QHC	QHC		BE16D A / B
	QHE	QHE	GC04-3000001~4399999	BE15G A / B
	QHP1	QHP1		BE15G B
		QHP1/A	GC04-4400001~	BE70B B / C
	QHQ4	QHQ4	GC04-3000001~4399999	BE15G A / B
		QHQ4/A	GC04-4400001~9999999	BE70B B / C
	QHZ	QHZ		BE15G B
	QKA2	QKA2	GC04-3000001~4399999	BE70B B / C
				BE15G B
	QMH	QMH		BE70B B / C
		QMH/A	GC04-4400001~	BE70B B / C
	QMX2	QMX2	GC04-3000001~4399999	
	QP	QP		BE15G A / B
		QP/A	GC04-4400001~	BE15G B / C

Model	Type	Parts catalogue type	Applicable engine serial No.	Applicable carburetor identification No.	Model	Type	Parts catalogue type	Applicable engine serial No.	Applicable carburetor identification No.
GX240K1 (1)	QT	QT	GC04-3000001~4399999	BE15G A / B	GX240K1 (1)	QXE4	QXE4	GC04-3000001~4399999	BE15G A / B BE70B B / C
		QT/A	GC04-4400001~	BE15G B / C			QXE4/A	GC04-4400001~9999999	BE70B B / C
	QTC2	QTC2	GC04-3000001~4399999	BE70B B / C		QXQ4	QXQ4	GC04-3000001~4399999	BE15G A / B BE70B B / C
		QTC2/A	GC04-4400001~9999999				QXQ4/A	GC04-4400001~9999999	BE70B B / C
	QW24	QW24		QXU		QXU	GC04-3000001~4399999	BE15G B BE70B B / C	
	QX	QX	GC04-3000001~4399999			BE15G A / B BE70B B / C	QXU/A	GC04-4400001~9999999	BE70B B / C
		QX/A	GC04-4400001~	BE70B B / C		RA	RA	GC04-3000001~4399999	BE15G A / B BE70B A / B / C
	QXB	QXB	GC04-3000001~4399999	BE15G A / B		RA2	RA2		GC04-4400001~9999999
	QXB7	QXB7	GC04-4400001~9999999	BE70B B / C			RA2/A		
		QXB7/A					BE15F B		
	QXC	QXC	GC04-3000001~4399999	BE16D A / B BE70A B		RH	RH	GC04-3000001~4399999	BE15G A / B BE15G A / B BE70B B / C
		QXC/A	GC04-4400001~	BE70A B		RHE	RHE		
	QXC9	QXC9	GC04-3000001~4399999	BE70A A / B		RHE4	RHE4		
		QXC9/A	GC04-4400001~9999999	BE70A B		RHQ4	RHQ4		
	QXE	QXE	GC04-3000001~4399999	BE15G A / B BE70B B / C			RHQ4/A		BE15G A / B
		QXE/A	GC04-4400001~	BE70B B / C		RJ	RJ	GC04-3000001~4399999	BE15G A / B
QXEB	QXEB	GC04-3000001~4399999	BE15G A / B						

Model	Type	Parts catalogue type	Applicable engine serial No.	Applicable carburetor identification No.
GX240K1 (1)	RJ	RJ/A	GC04-4400001~	BE15G B / C
	RSC2	RSC2	GC04-3000001~4399999	BE70B A / B / C
	RSS1	RSS1		BE15G B
	RTB2	RSS1/A	GC04-4400001~	BE15G B / C
		RTB2	GC04-3000001~4399999	BE70B A / B / C
	RX	RTB2/A	GC04-4400001~9999999	BE70B B / C
		RX	GC04-3000001~4399999	BE15G A / B BE70B B / C
	RXQ4	RX/A	GC04-4400001~	BE70B B / C
		RXQ4	GC04-3000001~4399999	BE15G A / B BE70B B / C
	SD	RXQ4/A	GC04-4400001~9999999	BE70B B / C
		SD	GC04-3000001~4399999	BE15F A / B
	SDB3	SD/A	GC04-4400001~	BE15F B
		SDB1	SDB1	GC04-3000001~4399999
	SDB3	SDB3		
	SE	SDB3/A	GC04-4400001~	BE15F B
		SE	GC04-3000001~4399999	BE15G A / B
	SE/A	GC04-4400001~9999999	BE15G B / C	

Model	Type	Parts catalogue type	Applicable engine serial No.	Applicable carburetor identification No.
GX240K1 (1)	SH	SH	GC04-3000001~4399999	BE15G A / B
	SHE	SHE		BE15G A / B BE70B B / C
	SHEZ	SHEZ		BE15G A / B
	SHW	SHW		BE15G B
	SJ	SHW/A	GC04-4400001~	BE15G B / C
		SJ	SJ	GC04-3000001~4399999
	SJC	SJ/A	GC04-4400001~	BE15G B / C
		SJC	SJC	GC04-3000001~4399999
	SJC1	SJC1	BE15G B	
	SJC5	SJC1/A	GC04-4400001~	BE15G B / C
		SJC5	SJC5	GC04-3000001~4399999
	SJG	SJC5/A	GC04-4400001~	BE15G B / C
		SJG	SJG	GC04-3000001~4399999
	SJP	SJG/A	GC04-4400001~	BE15G B / C
		SJP	SJP	GC04-3000001~4399999
	SK	SK		
SMS	SMS			

Model	Type	Parts catalogue type	Applicable engine serial No.	Applicable carburetor identification No.
GX240K1 (1)	SMS	SMS/A	GC04-4400001~	BE15G B / C
	SMX2	SMX2	GC04-3000001~4399999	BE70B A / B / C
		SMX2/A	GC04-4400001~9999999	BE70B B / C
	SNC1	SNC1	GC04-3000001~4399999	BE15F A / B
	SNE1	SNE1		BE15G A / B
	SNR	SNR		BE15G A / B BE70B B / C
		SNR/A	GC04-4400001~	BE70B B / C
	STP	STP	GC04-3000001~4399999	BE15G A / B BE70B B / C
		STP/A	GC04-4400001~	BE70B B / C
	STQ	STQ	GC04-3000001~4399999	BE15G A / B BE70B B / C
		STQ/A	GC04-4400001~9999999	BE70B B / C
	SW	SW	GC04-3000001~4399999	BE15G A / B
	SWE	SWE		BE15G A / B BE70B B / C
	SX	SX		GC04-4400001~
		SX/A	GC04-4400001~	BE70B B / C
SXB	SXB	GC04-3000001~4399999	BE15G A / B	
SXE	SXE			

Model	Type	Parts catalogue type	Applicable engine serial No.	Applicable carburetor identification No.
GX240K1 (1)	SXEB	SXEB	GC04-3000001~4399999	BE15G A / B
	SXE4	SXE4		BE15G A / B BE70B B / C
		SXE4/A	GC04-4400001~9999999	BE70B B / C
	SXQ4	SXQ4	GC04-3000001~4399999	BE15G A / B BE70B B / C
		SXQ4/A	GC04-4400001~9999999	BE70B B / C
	SXU	SXU	GC04-3000001~4399999	BE15G B BE70B B / C
		SXU/A	GC04-4400001~9999999	BE70B B / C
	VA	VA	GC04-3000001~4399999	BE15G A / B
	VAH1	VAH1		BE70B A / B / C
	VA2	VA2	GC04-4400001~9999999	BE70B B / C
		VA2/A		
	VDG2	VDG2	GC04-3000001~4399999	BE70B B / C
		VDG2/A	GC04-4400001~9999999	
	VH	VH	GC04-3000001~4399999	BE15G A / B BE70B B / C
		VH/A	GC04-4400001~	BE70B B / C
VH12	VH12	GC04-3000001~4399999	BE70B A / B / C	
	VH12/A	GC04-4400001~9999999	BE70B B / C	

Model	Type	Parts catalogue type	Applicable engine serial No.	Applicable carburetor identification No.
GX240K1 (1)	VMT2	VMT2	GC04-4400001~9999999	BE72C B / C
	VMX	VMX	GC04-3000001~4399999	BE15G B BE70B B / C
	VNG	VNG		BE15G A / B
	VSB1	VSB1	GC04-4400001~	BE20B B BE72C B
		VSB1/A		BE72C B BE72L A
	VS3	VS3	GC04-4400001~	BE72L A
	VS4	VS4		BE72L A
	VTA	VTA	GC04-3000001~4399999	BE15G A / B
	VTA2	VTA2	GC04-4400001~9999999	BE70B B / C
		VTA2/A		
	VTE2	VTE2	GC04-3000001~4399999	BE72C B
	VWC2	VWC2	GC04-4400001~9999999	BE70B A / B / C
		VWC2/A		BE70B B / C
	VX	VX	GC04-3000001~4399999	BE15G A / B BE70B B / C
		VX/A	GC04-4400001~	BE70B B / C
VXB	VXB	GC04-3000001~4399999	BE15G A / B BE70B B / C	
	VXB/A	GC04-4400001~9999999	BE70B B / C	

Model	Type	Parts catalogue type	Applicable engine serial No.	Applicable carburetor identification No.
GX240K1 (1)	VXB7	VXB7	GC04-3000001~4399999	BE70B B / C
		VXB7/A	GC04-4400001~9999999	
	VXE	VXE	GC04-3000001~4399999	BE15G A / B BE70B B / C
		VXE/A	GC04-4400001~	BE70B B / C
	VXEB	VXEB	GC04-3000001~4399999	BE15G A / B BE70B B / C
		VXEB/A	GC04-4400001~	BE70B B / C
	VXQ4	VXQ4	GC04-3000001~4399999	BE15G A / B BE70B B / C
		VXQ4/A	GC04-4400001~9999999	
	VXQ7	VXQ7	GC04-3000001~4399999	BE70B B / C
		VXQ7/A	GC04-4400001~9999999	
	VXU	VXU	GC04-3000001~4399999	BE15G A / B BE70B B / C
		VXU/A	GC04-4400001~	BE70B B / C
	VXU1	VXU1	GC04-3000001~4399999	BE15G B BE70B B / C
		VXU1/A	GC04-4400001~9999999	BE70B B / C
	WH	WH	GC04-3000001~4399999	BE15G A / B
WJ	WJ	GC04-4400001~		
	WJ/A		BE15G B / C	

Model	Type	Parts catalogue type	Applicable engine serial No.	Applicable carburetor identification No.
GX240K1 (1)	WKA	WKA	GC04- 3000001~4399999	BE19B A / B
	WKD6	WKD6	GC04- 4400001~9999999	BE70B B / C
		WKD6/A		
	WKT2	WKT2	GC04- 3000001~4399999	BE70B A / B / C
		WKT2/A	GC04- 4400001~9999999	
	WKT4	WKT4	GC04- 3000001~4399999	BE70B B / C
		WKT4/A	GC04- 4400001~9999999	
WMK	WMK	GC04- 4400001~	BE15F B	
GX240K1 (2)	L1	L1	GC04- 3000001~4399999	BE15F A / B BE15G A / B BE16D A / B
		L1/A	GC04- 4400001~	BE15F B BE15G B / C BE16D B
	P1	P1	GC04- 3000001~4399999	BE15F A / B BE15G A / B BE16D A / B
	Q1	Q1	GC04- 4400001~	BE15F B BE15G B / C BE16D B
		Q1/A		

Model	Type	Parts catalogue type	Applicable engine serial No.	Applicable carburetor identification No.
GX240K1 (2)	R1	R1	GC04- 3000001~4399999	BE15F A / B BE15G A / B BE16D A / B
		R1/A	GC04- 4400001~	BE15F B BE15G B / C BE16D B
	S1	S1	GC04- 3000001~4399999	BE15F A / B BE15G A / B BE16D A
		S1/A	GC04- 4400001~	BE15F B BE15G B / C BE16D A
	V1	V1	GC04- 3000001~4399999	BE15F A / B BE15G A / B BE16D A / B
	W1	W1		
GX240K1 (3) (Propane)	VXP	VXP	GDAC- 1000001~1099999	BEL2A A
		VXP/A	GDAC- 1100001~	
	VXQP	VXQP	GDAC- 1000001~1099999	

* Of carburetor identification numbers, only the portions underlined in the example below are used for registration.

GX240K1 (1)(2) BE 20B A KC ナ

Ⓐ Ⓑ

GX240K1 (3) BE L2A A KC ナ

Features of each type

• See the following table for the features of each type. (Items in brackets are optional)

Specifications		Model	GX240K1									
		Type	Standard equipment (1)									
			EDN	EDN2	EDS	EDS1	EDS2	EDS3	EDS5	EDS6	EDT1	EDT2
Crankshaft	25mm Ø Straight											
	25.4mm Ø Straight											
	20mm Ø Spline											
	M20 Stepped thread											
	1" Thread											
	1/5"Ø Tapered		●	●	●	●	●	●	●	●	●	●
	5/16"Ø Tapered											
Coil	Lamp coil (12V-25W)		●	●								
	Lamp coil (6V-25W)											
	Lamp coil (12V-50W)											
	Charge coil (1A)				●	●	●	●		●		
	Charge coil (2.8A)											
	Charge coil (3A)											
	Charge coil (10A)											
	Charge coil (12V/18A)								●			
Reduction	1/2 Reduction (with clutch)											
	1/2 Reduction (with chain)											
	1/6 Reduction (with gear)											
Starter motor					●	●	●	●	●	●		

Specifications		Model	GX240K1									
		Type	Standard equipment (1)									
			EDT3	EDT6	ED2	ED3	ED4	ED5	EN	EN2	ES	ES1
Crankshaft	25mm Ø Straight											
	25.4mm Ø Straight											
	20mm Ø Spline											
	M20 Stepped thread											
	1" Thread											
	1/5"Ø Tapered		●	●	●	●	●	●	●	●	●	●
	5/16"Ø Tapered											
Coil	Lamp coil (12V-25W)				●					●		
	Lamp coil (6V-25W)											
	Lamp coil (12V-50W)											
	Charge coil (1A)					●						
	Charge coil (2.8A)											
	Charge coil (3A)											
	Charge coil (10A)											
	Charge coil (12V/18A)											
Reduction	1/2 Reduction (with clutch)											
	1/2 Reduction (with chain)											
	1/6 Reduction (with gear)											
Starter motor						●						

Specifications		Model	GX240K1									
		Type	Standard equipment (1)									
			ES2	ES3	ET	ETS	ETX	HA	HAQ	HA2	HH	HHQ4
Crankshaft	25mm Ø Straight											
	25.4mm Ø Straight											
	20mm Ø Spline							●	●	●	●	●
	M20 Stepped thread											
	1" Thread											
	1/5"Ø Tapered		●	●	●	●	●					
	5/16"Ø Tapered											
Coil	Lamp coil (12V-25W)											
	Lamp coil (6V-25W)											
	Lamp coil (12V-50W)											
	Charge coil (1A)				●							
	Charge coil (2.8A)											
	Charge coil (3A)											
	Charge coil (10A)											
	Charge coil (12V/18A)											
Reduction	1/2 Reduction (with clutch)											
	1/2 Reduction (with chain)											
	1/6 Reduction (with gear)							●	●	●	●	●
Starter motor					●							

Specifications		Model	GX240K1									
		Type	Standard equipment (1)									
			HTX	HX	HXQ4	LD	LDB1	LDB3	LH	LHE	LHE4	LHZ
Crankshaft	25mm Ø Straight											
	25.4mm Ø Straight											
	20mm Ø Spline		●	●	●	●	●	●	●	●	●	●
	M20 Stepped thread											
	1" Thread											
	1/5"Ø Tapered											
	5/16"Ø Tapered											
Coil	Lamp coil (12V-25W)											
	Lamp coil (6V-25W)											
	Lamp coil (12V-50W)											
	Charge coil (1A)									●	●	
	Charge coil (2.8A)											
	Charge coil (3A)											
	Charge coil (10A)											
Charge coil (12V/18A)												
Reduction	1/2 Reduction (with clutch)											
	1/2 Reduction (with chain)				●	●	●	●	●	●	●	●
	1/6 Reduction (with gear)		●	●	●							
Starter motor										●	●	

Specifications		Model	GX240K1								
		Type	Standard equipment (1)								
		LJ	LJG	LJG1	LJS	LK	LKS	LM9	LNJ	LNZ	LP
Crankshaft	25mm Ø Straight										
	25.4mm Ø Straight										
	20mm Ø Spline	●	●	●	●	●	●	●	●	●	●
	M20 Stepped thread										
	1" Thread										
	1/5"Ø Tapered										
	5/16"Ø Tapered										
Coil	Lamp coil (12V-25W)										
	Lamp coil (6V-25W)										
	Lamp coil (12V-50W)										
	Charge coil (1A)										
	Charge coil (2.8A)								●	●	
	Charge coil (3A)										
	Charge coil (10A)						●				
Charge coil (12V/18A)											
Reduction	1/2 Reduction (with clutch)										
	1/2 Reduction (with chain)	●	●	●	●	●	●	●	●	●	●
	1/6 Reduction (with gear)										
Starter motor							●		●	●	

Specifications		Model	GX240K1									
		Type	Standard equipment (1)									
			LSS4	LSS5	LSX	LT	LW	LX	LXF	LXQ4	LXZ	LX2
Crankshaft	25mm Ø Straight											
	25.4mm Ø Straight											
	20mm Ø Spline		●	●	●	●	●	●	●	●	●	●
	M20 Stepped thread											
	1" Thread											
	1/5"Ø Tapered											
	5/16"Ø Tapered											
Coil	Lamp coil (12V-25W)											
	Lamp coil (6V-25W)											
	Lamp coil (12V-50W)				●	●						
	Charge coil (1A)											
	Charge coil (2.8A)											
	Charge coil (3A)											
	Charge coil (10A)			●								
Charge coil (12V/18A)												
Reduction	1/2 Reduction (with clutch)											
	1/2 Reduction (with chain)		●	●	●	●	●	●	●	●	●	●
	1/6 Reduction (with gear)											
Starter motor				●								

Specifications		Model	GX240K1									
		Type	Standard equipment (1)									
			PA	PAE	PA2	PMT2	PX	QA	QAB2	QAE	QAE2	QAG
Crankshaft	25mm Ø Straight											
	25.4mm Ø Straight							●	●	●	●	●
	20mm Ø Spline											
	M20 Stepped thread											
	1" Thread		●	●	●	●	●					
	1/5"Ø Tapered											
	5/16"Ø Tapered											
Coil	Lamp coil (12V-25W)											
	Lamp coil (6V-25W)											
	Lamp coil (12V-50W)											
	Charge coil (1A)											
	Charge coil (2.8A)											
	Charge coil (3A)									●	●	
	Charge coil (10A)			●								
	Charge coil (12V/18A)											
Reduction	1/2 Reduction (with clutch)											
	1/2 Reduction (with chain)											
	1/6 Reduction (with gear)											
Starter motor				●						●	●	

Specifications		Model	GX240K1									
		Type	Standard equipment (1)									
			QAG2	QAQ	QAQ4	QAR2	QA2	QC12	QD	QDA	QE	QH
Crankshaft	25mm Ø Straight											
	25.4mm Ø Straight		●	●	●	●	●	●	●	●	●	●
	20mm Ø Spline											
	M20 Stepped thread											
	1" Thread											
	1/5"Ø Tapered											
	5/16"Ø Tapered											
Coil	Lamp coil (12V-25W)											
	Lamp coil (6V-25W)											
	Lamp coil (12V-50W)		●									
	Charge coil (1A)											
	Charge coil (2.8A)											
	Charge coil (3A)											
	Charge coil (10A)											
	Charge coil (12V/18A)					●						
Reduction	1/2 Reduction (with clutch)											
	1/2 Reduction (with chain)											
	1/6 Reduction (with gear)											
Starter motor						●						

Specifications		Model	GX240K1									
		Type	Standard equipment (1)									
			QHB2	QHC	QHE	QHP1	QHQ4	QHZ	QKA2	QMH	QMX2	QP
Crankshaft	25mm Ø Straight											
	25.4mm Ø Straight		●	●	●	●	●	●	●	●	●	●
	20mm Ø Spline											
	M20 Stepped thread											
	1" Thread											
	1/5"Ø Tapered											
	5/16"Ø Tapered											
Coil	Lamp coil (12V-25W)											
	Lamp coil (6V-25W)											
	Lamp coil (12V-50W)											●
	Charge coil (1A)			●								
	Charge coil (2.8A)											
	Charge coil (3A)											
	Charge coil (10A)								●			
	Charge coil (12V/18A)											
Reduction	1/2 Reduction (with clutch)											
	1/2 Reduction (with chain)							●				
	1/6 Reduction (with gear)											
Starter motor				●								

Specifications		Model	GX240K1									
		Type	Standard equipment (1)									
			QT	QTC2	QW24	QX	QXB	QXB7	QXC	QXC9	QXE	QXEB
Crankshaft	25mm Ø Straight											
	25.4mm Ø Straight		●	●	●	●	●	●	●	●	●	●
	20mm Ø Spline											
	M20 Stepped thread											
	1" Thread											
	1/5"Ø Tapered											
	5/16"Ø Tapered											
Coil	Lamp coil (12V-25W)											
	Lamp coil (6V-25W)											
	Lamp coil (12V-50W)											
	Charge coil (1A)										●	●
	Charge coil (2.8A)											
	Charge coil (3A)											
	Charge coil (10A)											
Charge coil (12V/18A)												
Reduction	1/2 Reduction (with clutch)											
	1/2 Reduction (with chain)											
	1/6 Reduction (with gear)											
Starter motor										●	●	

Specifications		Model	GX240K1									
		Type	Standard equipment (1)									
			QXE4	QXQ4	QXU	RA	RA2	RD	RH	RHE	RHE4	RHQ4
Crankshaft	25mm Ø Straight					●	●	●	●	●	●	●
	25.4mm Ø Straight		●	●	●							
	20mm Ø Spline											
	M20 Stepped thread											
	1" Thread											
	1/5"Ø Tapered											
	5/16"Ø Tapered											
Coil	Lamp coil (12V-25W)											
	Lamp coil (6V-25W)											
	Lamp coil (12V-50W)											
	Charge coil (1A)		●							●	●	
	Charge coil (2.8A)											
	Charge coil (3A)											
	Charge coil (10A)											
Reduction	Charge coil (12V/18A)											
	1/2 Reduction (with clutch)					●	●	●	●	●	●	●
	1/2 Reduction (with chain)											
Starter motor	1/6 Reduction (with gear)											
			●							●	●	

Specifications		Model	GX240K1									
		Type	Standard equipment (1)									
			RJ	RSC2	RSS1	RTB2	RX	RXQ4	SD	SDB1	SDB3	SE
Crankshaft	25mm Ø Straight		●	●	●	●	●	●	●	●	●	●
	25.4mm Ø Straight											
	20mm Ø Spline											
	M20 Stepped thread											
	1" Thread											
	1/5"Ø Tapered											
	5/16"Ø Tapered											
Coil	Lamp coil (12V-25W)											
	Lamp coil (6V-25W)											
	Lamp coil (12V-50W)			●								
	Charge coil (1A)				●							
	Charge coil (2.8A)											
	Charge coil (3A)											
	Charge coil (10A)											
Charge coil (12V/18A)												
Reduction	1/2 Reduction (with clutch)		●	●	●	●	●	●				
	1/2 Reduction (with chain)											
	1/6 Reduction (with gear)											
Starter motor					●							

Specifications		Model	GX240K1									
		Type	Standard equipment (1)									
			SH	SHE	SHEZ	SHW	SJ	SJC	SJC1	SJC5	SJG	SJP
Crankshaft	25mm Ø Straight		●	●	●	●	●	●	●	●	●	●
	25.4mm Ø Straight											
	20mm Ø Spline											
	M20 Stepped thread											
	1" Thread											
	1/5"Ø Tapered											
	5/16"Ø Tapered											
Coil	Lamp coil (12V-25W)											
	Lamp coil (6V-25W)											
	Lamp coil (12V-50W)											
	Charge coil (1A)		●	●								
	Charge coil (2.8A)											
	Charge coil (3A)					●						
	Charge coil (10A)											
Reduction	Charge coil (12V/18A)											
	1/2 Reduction (with clutch)											
	1/2 Reduction (with chain)											
Starter motor	1/6 Reduction (with gear)											
			●	●	●							

Specifications		Model	GX240K1									
		Type	Standard equipment (1)									
			SK	SMS	SMX2	SNC1	SNE1	SNR	STP	STQ	SW	SWE
Crankshaft	25mm Ø Straight		●	●	●	●	●	●	●	●	●	●
	25.4mm Ø Straight											
	20mm Ø Spline											
	M20 Stepped thread											
	1" Thread											
	1/5"Ø Tapered											
	5/16"Ø Tapered											
Coil	Lamp coil (12V-25W)											
	Lamp coil (6V-25W)											
	Lamp coil (12V-50W)				●						●	
	Charge coil (1A)											●
	Charge coil (2.8A)											
	Charge coil (3A)											
	Charge coil (10A)						●					
	Charge coil (12V/18A)											
Reduction	1/2 Reduction (with clutch)											
	1/2 Reduction (with chain)											
	1/6 Reduction (with gear)											
Starter motor							●					●

Specifications		Model	GX240K1									
		Type	Standard equipment (1)									
			SX	SXB	SXE	SXEB	SXE4	SXQ4	SXU	VA	VAH1	VA2
Crankshaft	25mm Ø Straight		●	●	●	●	●	●	●			
	25.4mm Ø Straight											
	20mm Ø Spline											
	M20 Stepped thread											
	1" Thread											
	1/5"Ø Tapered											
	5/16"Ø Tapered									●	●	●
Coil	Lamp coil (12V-25W)											
	Lamp coil (6V-25W)											
	Lamp coil (12V-50W)											
	Charge coil (1A)			●	●	●						
	Charge coil (2.8A)											
	Charge coil (3A)											
	Charge coil (10A)											
Reduction	Charge coil (12V/18A)											
	1/2 Reduction (with clutch)											
	1/2 Reduction (with chain)											
Starter motor	1/6 Reduction (with gear)											
				●	●	●						

Specifications		Model	GX240K1									
		Type	Standard equipment (1)									
			VDG2	VH	VH12	VMT2	VMX	VNG	VSB1	VS3	VS4	VTA
Crankshaft	25mm Ø Straight											
	25.4mm Ø Straight											
	20mm Ø Spline											
	M20 Stepped thread											
	1" Thread											
	1/5"Ø Tapered											
	5/16"Ø Tapered		●	●	●	●	●	●	●	●	●	●
Coil	Lamp coil (12V-25W)											
	Lamp coil (6V-25W)											
	Lamp coil (12V-50W)											
	Charge coil (1A)											
	Charge coil (2.8A)											
	Charge coil (3A)											
	Charge coil (10A)											
	Charge coil (12V/18A)											
Reduction	1/2 Reduction (with clutch)											
	1/2 Reduction (with chain)											
	1/6 Reduction (with gear)											
Starter motor												

Specifications		Model	GX240K1									
		Type	Standard equipment (1)									
			VTA2	VTE2	VWC2	VX	VXB	VXB7	VXE	VXEB	VXQ4	VXQ7
Crankshaft	25mm Ø Straight											
	25.4mm Ø Straight											
	20mm Ø Spline											
	M20 Stepped thread											
	1" Thread											
	1/5"Ø Tapered			●								
	5/16"Ø Tapered		●		●	●	●	●	●	●	●	●
Coil	Lamp coil (12V-25W)			●								
	Lamp coil (6V-25W)											
	Lamp coil (12V-50W)											
	Charge coil (1A)							●	●			
	Charge coil (2.8A)											
	Charge coil (3A)											
	Charge coil (10A)											
	Charge coil (12V/18A)											
Reduction	1/2 Reduction (with clutch)											
	1/2 Reduction (with chain)											
	1/6 Reduction (with gear)											
Starter motor									●	●		

Specifications		Model	GX240K1								
		Type	Standard equipment (1)								
			VXU	VXU1	WH	WJ	WKA	WKD6	WKT2	WKT4	WMK
Crankshaft	25mm Ø Straight										
	25.4mm Ø Straight										
	20mm Ø Spline										
	M20 Stepped thread			●	●	●	●	●	●	●	●
	1" Thread										
	1/5"Ø Tapered										
	5/16"Ø Tapered		●	●							
Coil	Lamp coil (12V-25W)										
	Lamp coil (6V-25W)										
	Lamp coil (12V-50W)										
	Charge coil (1A)										
	Charge coil (2.8A)										
	Charge coil (3A)										
	Charge coil (10A)										
	Charge coil (12V/18A)						●				
Reduction	1/2 Reduction (with clutch)										
	1/2 Reduction (with chain)										
	1/6 Reduction (with gear)										
Starter motor							●				

Specifications		Model	GX240K1							
		Type	Selective equipment (2)						Propane (3)	
			L1	P1	Q1	R1	S1	V1	W1	VXP
Crankshaft	25mm Ø Straight				●	●				
	25.4mm Ø Straight			●						
	20mm Ø Spline	●								
	M20 Stepped thread						●			
	1" Thread		●							
	1/5"Ø Tapered									
	5/16"Ø Tapered						●		●	●
Coil	Lamp coil (12V-25W)	(●)	(●)	(●)	(●)	(●)	(●)	(●)		
	Lamp coil (6V-25W)	(●)	(●)	(●)	(●)	(●)	(●)	(●)		
	Lamp coil (12V-50W)	(●)	(●)	(●)	(●)	(●)	(●)	(●)		
	Charge coil (1A)	(●)	(●)	(●)	(●)	(●)	(●)	(●)		
	Charge coil (2.8A)									
	Charge coil (3A)	(●)	(●)	(●)	(●)	(●)	(●)	(●)		
	Charge coil (10A)	(●)	(●)	(●)	(●)	(●)	(●)	(●)		
	Charge coil (12V/18A)	(●)	(●)	(●)	(●)	(●)	(●)	(●)		
Reduction	1/2 Reduction (with clutch)				●					
	1/2 Reduction (with chain)	●								
	1/6 Reduction (with gear)									
Starter motor		(●)	(●)	(●)	(●)	(●)	(●)	(●)		

Fuel hose, general purpose hoses and vinyl hose

- The standard part fuel hose, general purpose hose and vinyl hose may be substituted by the coiled bulk part.
- When ordering the standard part fuel hose, general purpose hose and vinyl hose use the bulk part number written in the parts catalog in brackets () underneath the part name.
- When exchanging the hose, cut and use at the specified length as mentioned in the part name.
(For the method of cutting the bulk part, and method of filling out orders etc., please refer to the instructions issued with the bulk part.)

Bulk part number of fuel hose, general purpose hose and vinyl hose.

Example: 9 5 0 0 1 - 7 5 0 0 1 - 5 0 M

Bulk part number:

Refers to the bulk part.

Marking code (fuel hose and general purpose hose)

Change code (Vinyl hose)

Indicates number mark or change sequence, however, the code for the bulk part must be strictly 0 (zero).

Types of code:

- | | | | | | |
|-------------|--|----------------|--|--------------|---|
| • Fuel hose | 2: Red outside braid
(3 mm inside dia. only) | • General hose | 1: Ash gray
2: Ash gray
3: Black
5: Black | • Vinyl hose | 1: Clear
2: Black
3: Light red
6: Light red
7: Pale black |
| | 5: Black inside braid | | | | |
| | 3: Red (3 mm inside dia. only) | | | | |
| | 4: Ash gray with red stripe
(3 mm inside dia. only) | | | | |
| | 6: Black | | | | |

Lengths:

- 001: 1 m (standard)
003: 3 m
008: 8 m } Application or specification of some parts is not settled.

I.D code: (fuel hose and general purpose hose)

- | | | | | |
|------------|--------------------|--------------------|-----------------------------|-----------------------------|
| 30: 3.0 mm | 50: 5.0 mm | 70: 7.0 mm | 11: 11 mm | 12: 12 (outside dia. 17) mm |
| 35: 3.5 mm | 55: 5.3 mm, 5.5 mm | 75: 7.3 mm, 7.5 mm | 91: 12 (outside dia. 15) mm | 14: 14 mm |
| 45: 4.5 mm | 65: 6.5 mm | 80: 8.0 mm | 92: 12 (outside dia. 16) mm | 17: 17 mm |

ID./OD. code: (vinyl hose)

- | | | | | |
|-------------------------|--------------------------|---------------------------|---------------------------|---------------------------|
| 01: ID. 2.9, OD. 6.8 mm | 12: ID. 5.0, OD. 7.0 mm | 21: ID. 8.0, OD. 9.0 mm | 37: ID. 11.0, OD. 15.0 mm | 50: ID. 16.0, OD. 19.0 mm |
| 03: ID. 3.0, OD. 6.0 mm | 10: ID. 5.0, OD. 8.0 mm | 23: ID. 8.0, OD. 12.0 mm | 38: ID. 12.0, OD. 13.0 mm | 55: ID. 17.5, OD. 20.5 mm |
| 05: ID. 3.5, OD. 6.5 mm | 11: ID. 5.0, OD. 9.0 mm | 25: ID. 9.0, OD. 11.0 mm | 39: ID. 12.0, OD. 14.0 mm | 60: ID. 22.0, OD. 27.0 mm |
| 07: ID. 4.0, OD. 7.0 mm | 14: ID. 6.0, OD. 9.0 mm | 27: ID. 9.0, OD. 13.0 mm | 40: ID. 12.0, OD. 16.0 mm | |
| 08: ID. 4.5, OD. 6.5 mm | 17: ID. 7.0, OD. 9.0 mm | 33: ID. 10.0, OD. 14.0 mm | 43: ID. 13.0, OD. 15.0 mm | |
| 09: ID. 4.5, OD. 8.0 mm | 19: ID. 7.0, OD. 11.0 mm | 36: ID. 11.0, OD. 13.0 mm | 45: ID. 14.0, OD. 18.0 mm | |

Hose type:

- 1: Fuel hose
3: Vinyl hose
5: General hose

⊙ **CAUTION: It is DANGEROUS to confuse the fuel hose with the general purpose hose or vinyl hose.**

Never use a general purpose hose or vinyl hose in place of a fuel hose or vice versa. Always use the correct bulk part in the parts catalogue, according to the service manual or the instructions issued with the bulk part.

FLAT RATE SERVICE TIME

Flat rate service time (FRT) means the standard time required to service a product, which is listed in this manual to help the dealers control the actual working process and calculate the service charge by using it as a guide.

FRT setting system

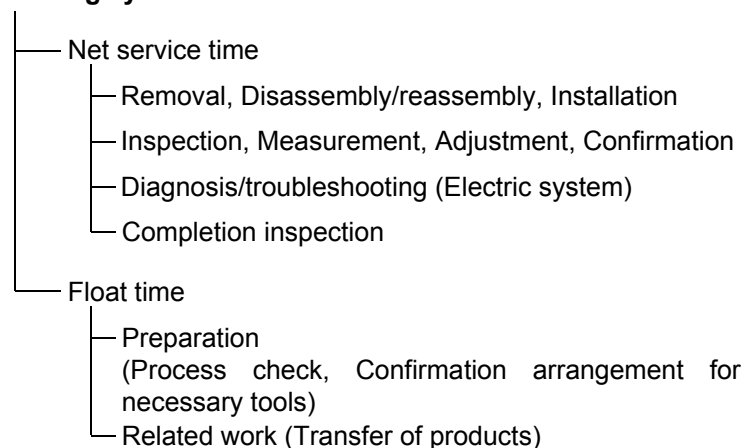

* Float time is set by multiplying the net service time by a given coefficient.

Editorial style

The service items shown in the text are listed with the exchange work time for the repair sales parts as the subject. Other representative service items not using repair parts (removal/installation, adjustment, inspection/measuring, and other work) are listed collectively in the list in the preface, classified according to the work.

FRT setting standard

- Decimal system (in unit of 0.1) is adopted to set FRT as it is convenient to calculate the wage.
Example: (0.1) → 6 minutes, (0.2) → 12 minutes
[Labor cost per hour] x [FRT] = [Wage]
- FRT is set with a hand tool.
- Service items and FRT can be subject to change depending on development of tools and service equipment and improvement in service procedure.

Work procedure

- As the work procedure is set with the work time according to the method in the separate Service Manual, refer to this Manual as required.
- Work methods permitting servicing in the shortest time still permitting assurance of safe work and product warranty are used for the setting of service items not listed in the Service Manual.
- Work basically is to be performed by one person, and when two or more people are required, setting is done as the total time for the number of people.
- The set value for the technological level of the workers uses a person with three years of experience in the repair of Honda products as the standard.
- Special tools and service equipment used to set FRT are those specified or recommended in Service Manual.

Service item whose FRT is not presented

- Accessories and service parts that are not listed to use in this manual.
 - Locations with little aging deterioration or breakage during normal use.
 - Service work that can be finished by one touch.
 - Service work that is seldom done (i.e. extremely small causes of trouble and service frequency).
 - Products and parts whose location for installation differs according to its status of use and application.
- * When FRT is not presented, please calculate wages based on appropriate actual work time.

Operation not included of FRT

- Oil and coolant water draining, Waiting time for warming up operation and etc..
- Additional operation that involves removal/installation of standard exterior equipment.
- Indirect time spent for service by visiting the customer, trade-in, and delivery.
- Indirect time required for ordering and delivery of parts.
- Cost for grease, adhesive agent, etc. used for service work.

**Explanation of FRT by using an example
(The example may differ from the actual presented items)**

Ref. No.	L.O.N.	(Relative ref. Number) Description	F.R.T.
①	1111L1	④ (1, 3, 4, 7) VALVE, INTAKE4.1	②
②		• NOTE: OHV type ⑥	⑦
③	1111L1A	• Includes: Engine removal and installation One head (intake all) add 1.4 ⑤	

- ① Reference No. of the illustration of part that shows location of the replacement work.
- ② FRT is an abbreviation of Flat Rate Time indicating the standard service time required for the replacement.
- ③ LON is an abbreviation of Labor Operation Number, and it is a classification of the service items by the work unit code.

The same operation code is used regardless of the models.

Standard operation is indicated with 6 digits code, and additional operation is indicated with 7 digits code.

- ④ Indicating the intake valve replacement and FRT4.1.
- ⑤ Indicating FRT1.4 that will be added when additional operation (whole intake side of one cylinder head) is done in association with intake valve replacement.

- ⑥ Indicating work condition or application condition of the service item.
- ⑦ Indicating work contents that are included in the service item.
- ⑧ Indicating a reference No. whose operation and time are the same as FRT4.1 for the intake valve.

(The application range is limited to the service items without an LON setting within a same block.)

**How to refer to the service item by using the sample
(intake valve replacement)**

Open to the page of the block where the intake valve's spare part illustration is shown.

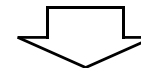

Look for the intake valve illustration, and refer to the service item and FRT that agree with the reference No.

Indication mark for the listing of service items that continues to the following page

Ref. No.	L.O.N.	(Relative ref. Number) Description	F.R.T.
2	1111L1	VALVE, INTAKE	4.1
	.	.	.
	.	.	.

+
Mark indicated at the last line.

Indication of the block with no setting of FRT

Ref. No.	L.O.N.	(Relative ref. Number) Description	F.R.T.
NO INFORMATION			

• LON code system

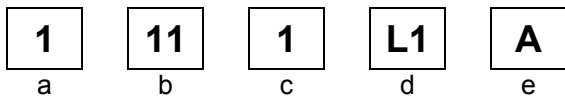

- a) Category code..... Engine
- b) Location/function code..... Engine upper
- c) Operation code..... Replace
- d) Operation sequence number (Unit code can be shown with alphabet)
..... Intake valve
(No regular rule of code)
- e) Additional code One head (intake all)
(No regular rule of code)

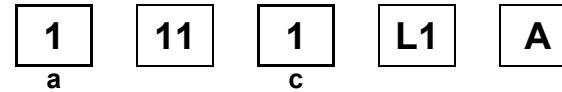

a) Category codes and classification

Code	Category
1	Engine
2	Power drive
3	Fuel & Exhaust
4	Frame & Body
5	Steering
6	Electrical
7	Axle & Brake
8	Control system
9	-
0	Attachments

c) Operation codes and classification

Code	Operation category
1	Replace, Removal/Installation, Change
2	Overhaul
3	Adjust, Rotation
4	(Paint-related work: Top-coat)
5	Test, Inspect/diagnose, Measurement
6	(Overhaul-related work: Rebore)
7	(Overhaul-related work: Reseal)
8	(Resurface)
9	(Paint-related work: Refinish)
0	Repair, Cleaning, Air bleeding

Major service items without using spare parts

- (1) Removal/Installation, (2) Adjustment,
(3) Inspection/Masurement, (4) Overhaul, (5) Other work

E: Engine, T: Transmission, D: Drive system,
B: Body and related parts

(1) Removal/Installation

Set with the parts configuration in the status of being removed from the product.

	LON	DESCRIPTION	FRT
E	1111L3	CYLINDER HEAD ASSEMBLY-REMOVAL/INSTALLATION	0.5

(2) Adjustment

	LON	DESCRIPTION	FRT
E	1113A1	VALVE CLEARANCE-ADJUSTMENT NOTE: For 1 product	0.3
	1163A0	CONTROL, THROTTLE/GOVERNOR-ADJUSTMENT	0.2
	3113A2	CARBURETOR IDLE-ADJUSTMENT	0.2

(3) Inspection, Measurement, Cleaning

	LON	DESCRIPTION	FRT
E	1105A0	ENGINE OIL-INSPECTION	0.1
	3120A0	AIR CLEANER-CLEANING INCLUDES: Air cleaner-inspection	0.1
	3130A0	SPARK ARRESTER-CLEANING	0.2
	6140A0	SPARK PLUG-ADJUSTMENT/CLEANING NOTE: For 1 product	0.1

(4) Overhaul

Work condition: The required Measurements, inspections, adjustments, and cleaning/washing of each part are performed, including the main body removal/installation work and the replacement of defective parts.

	LON	DESCRIPTION	FRT
E	3112A0	CARBURETOR-OVERHAUL INCLUDES: All necessary adjustment	0.6

(5) Other work

	LON	DESCRIPTION	FRT
E	1101E1	ENGINE OIL-CHANGE INCLUDES: Engine oil-inspection	0.1

ENGINE GROUP

D 8

E-2

CYLINDER HEAD

E 1

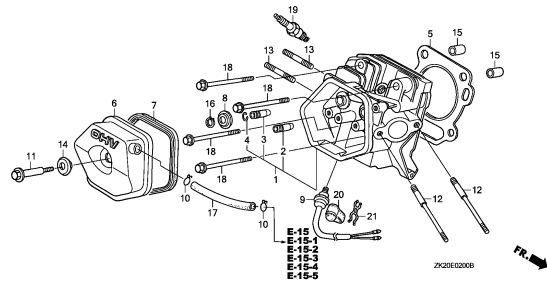

E-3

CYLINDER BARREL

E10

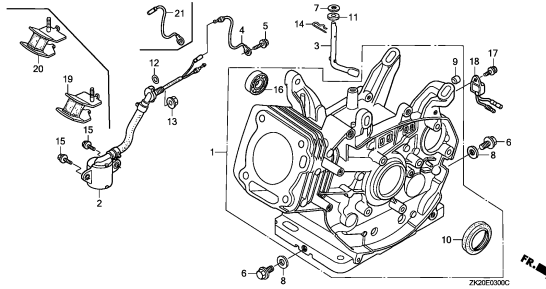

E-6

CRANKCASE COVER(1)

F 2

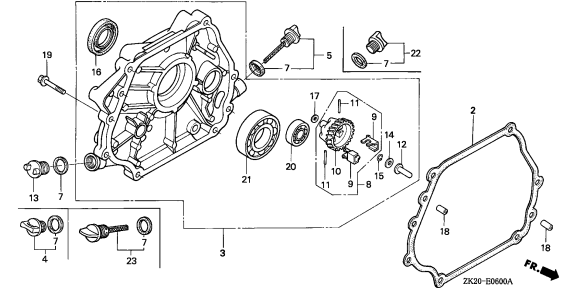

E-6-1

CRANKCASE COVER(2)

F14

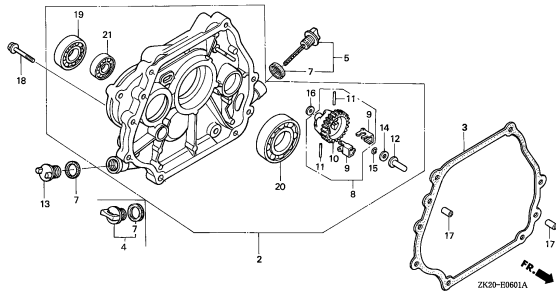

E-6-2

CRANKCASE COVER(3)

F15

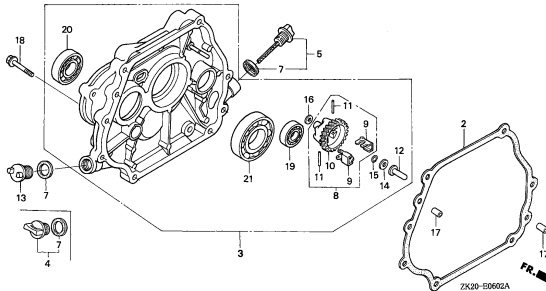

E-6-3

CRANKCASE COVER(4)

F16

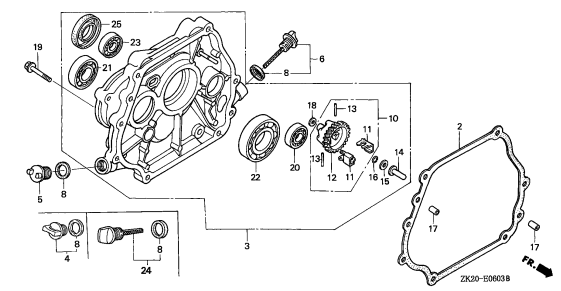

E-6-4

CRANKCASE COVER(5)

G 4

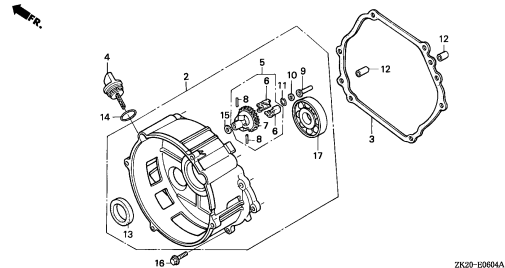

E-7

CRANKSHAFT

G 6

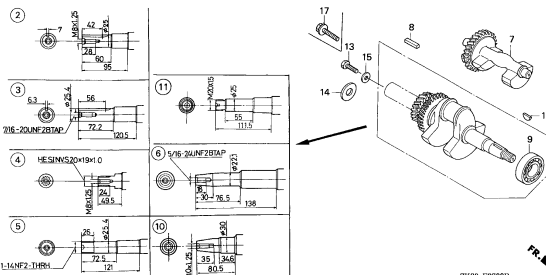

E-8

PISTON

G 9

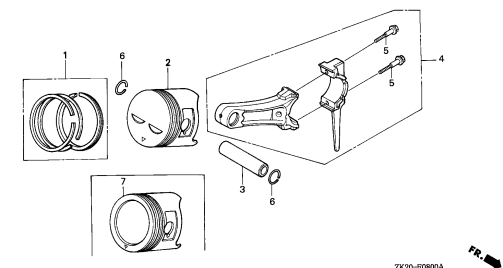

2

ENGINE GROUP

D 9

E-9

CAMSHAFT

H 7

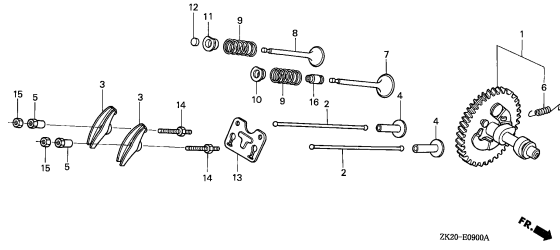

E-11

RECOIL STARTER(1)

H11

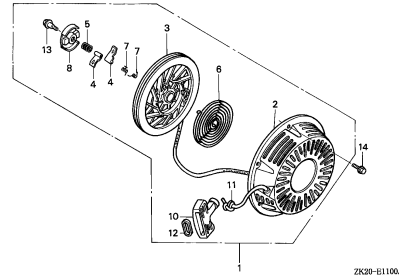

E-11-1

RECOIL STARTER(2)

I 5

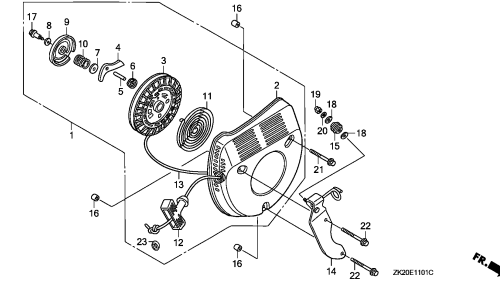

E-12

FAN COVER(1)

I 7

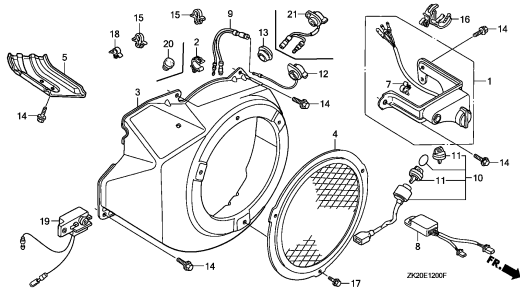

E-12-1

FAN COVER(2)

I13

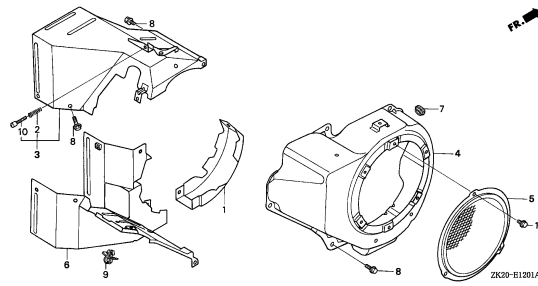

E-14

CARBURETOR(1)

I14

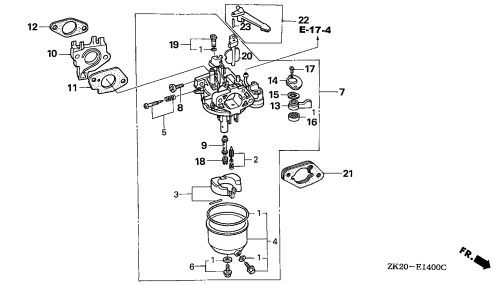

E-14-1

CARBURETOR(2)

J 1

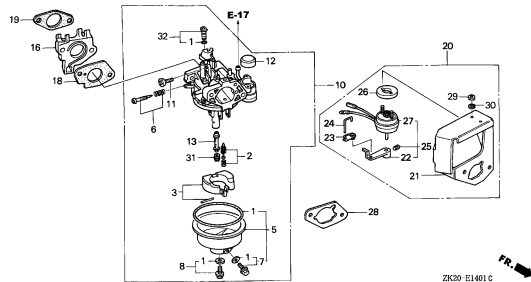

E-14-2

CARBURETOR(3)

J 3

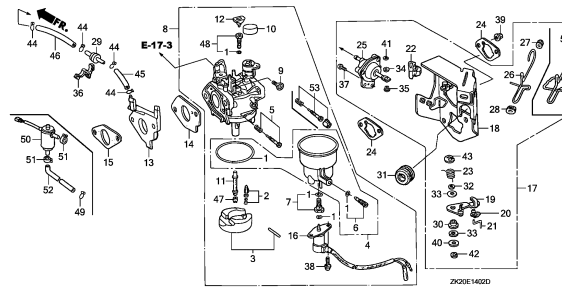

E-14-3

CARBURETOR(4)

J 9

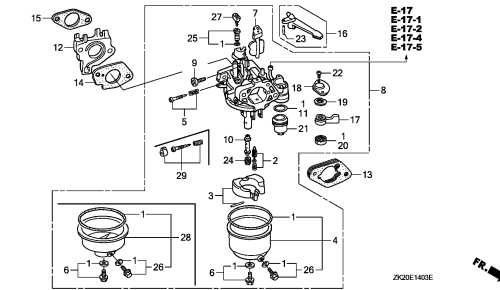

2

ENGINE GROUP

D10

E-14-4

CARBURETOR(5)

K13

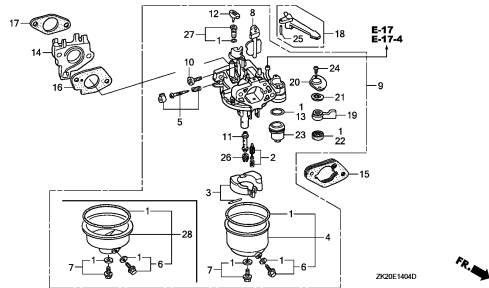

E-14-5

CARBURETOR(6)

K16

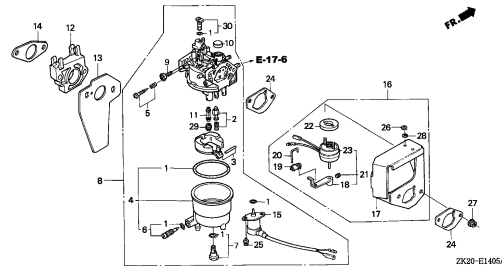

E-14-6

CARBURETOR(7)

L 2

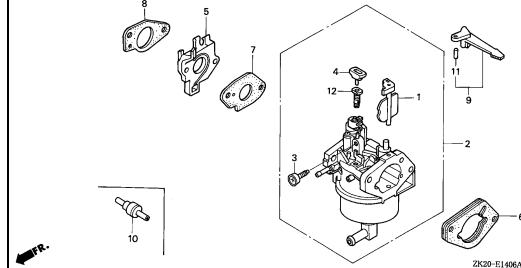

E-15

AIR CLEANER(1)

L 3

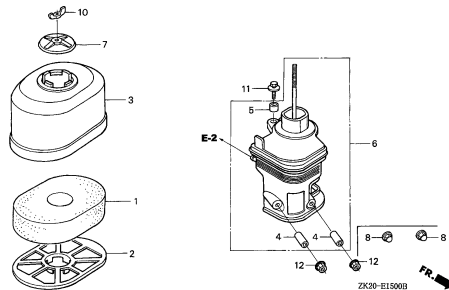

E-15-1

AIR CLEANER(2)

L 5

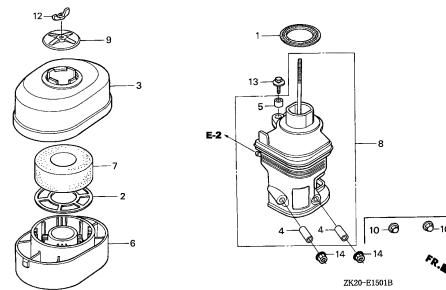

E-15-2

AIR CLEANER(3)

L 6

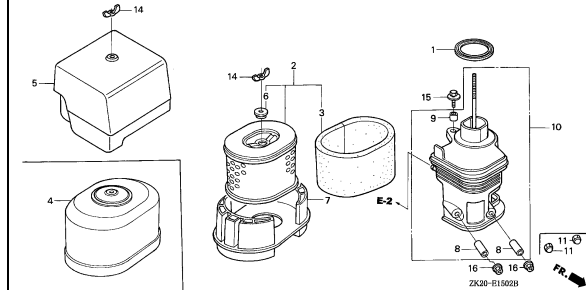

E-15-3

AIR CLEANER(4)

L13

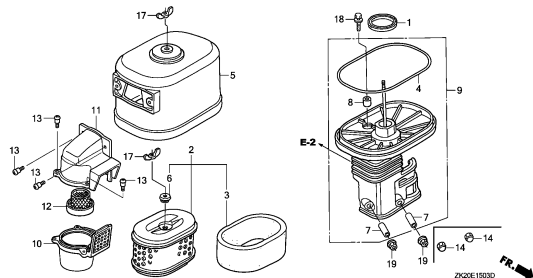

E-15-4

AIR CLEANER(5)

L15

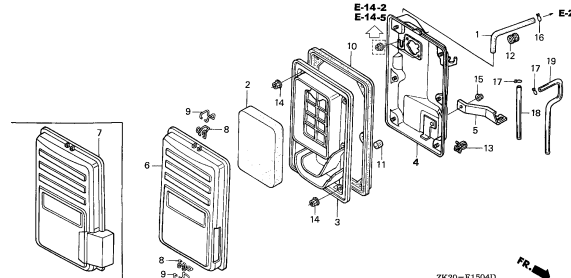

E-15-5

AIR CLEANER(6)

M 1

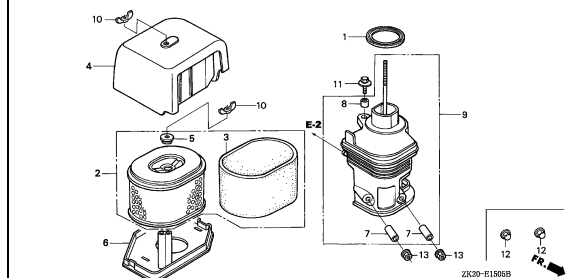

2

ENGINE GROUP

D11

E-16

MUFFLER(1)

M 2

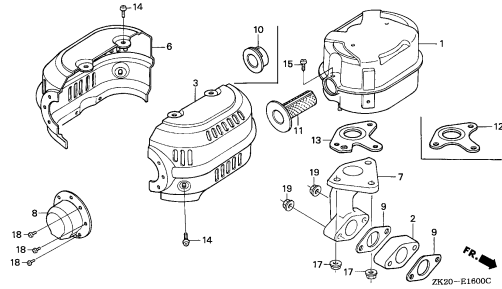

E-16-1

MUFFLER(2)

M 5

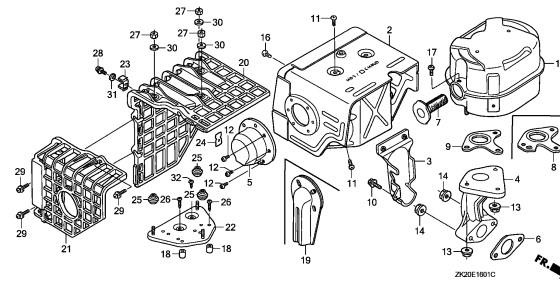

E-16-2

MUFFLER(3)

M11

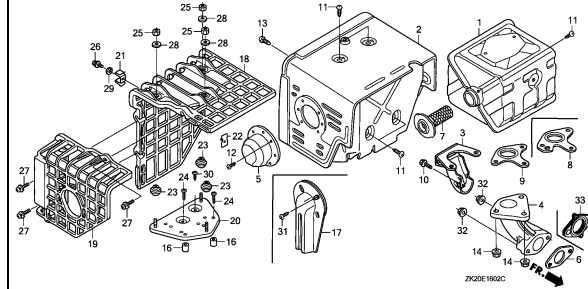

E-16-3

MUFFLER(4)

M15

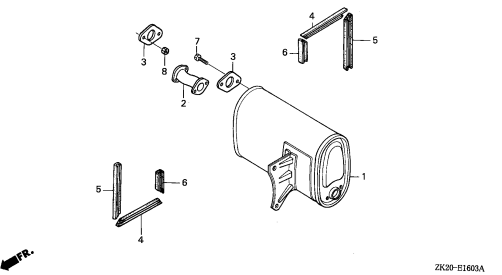

E-16-4

MUFFLER(5)

M16

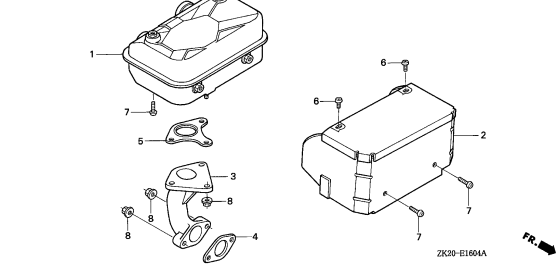

E-16-5

MUFFLER(6)

N 1

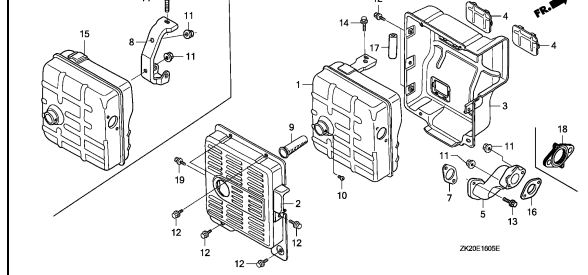

E-17

FUEL TANK(1)

N 3

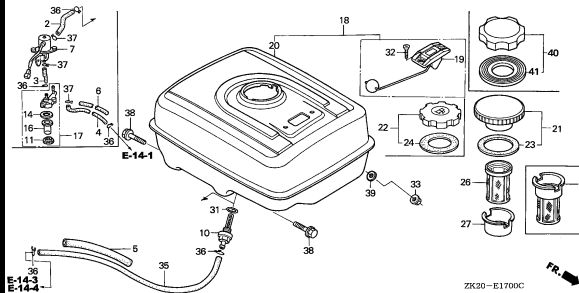

E-17-1

FUEL TANK(2)

N 7

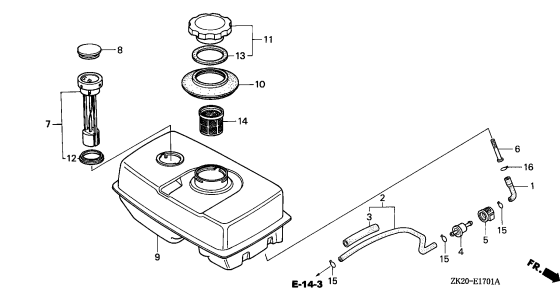

E-17-2

FUEL TANK(3)

N 8

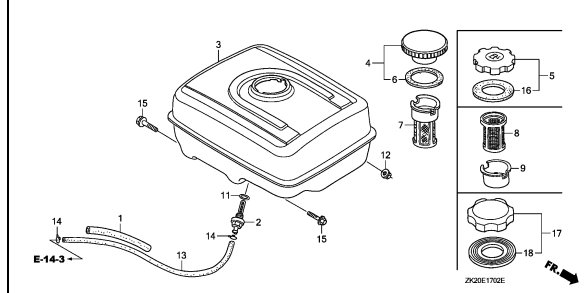

2

ENGINE GROUP

D12

E-17-3

FUEL TANK(4)

N11

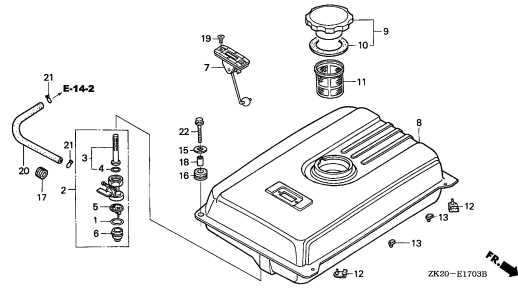

ZK30-E1703B

E-17-4

FUEL TANK(5)

N13

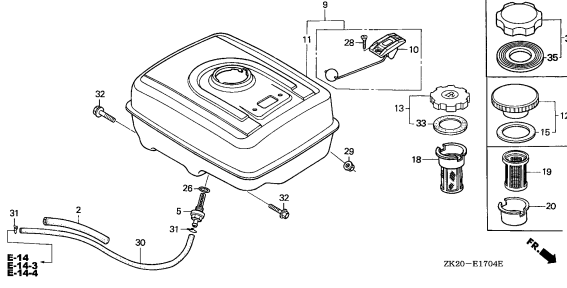

ZK30-E1704E

E-17-5

FUEL TANK(6)

2-B 3

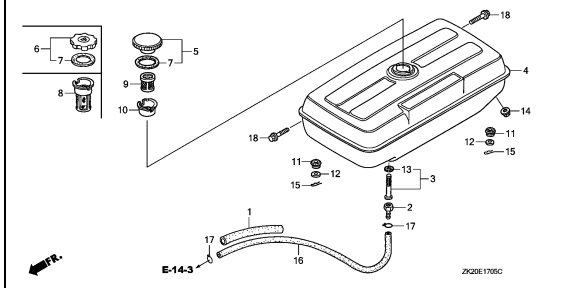

ZK30E1750C

E-17-6

FUEL TANK(7)

2-B 4

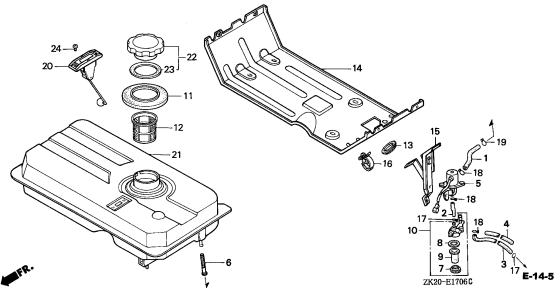

ZK30-E1756C

E-19

FLYWHEEL

2-B 5

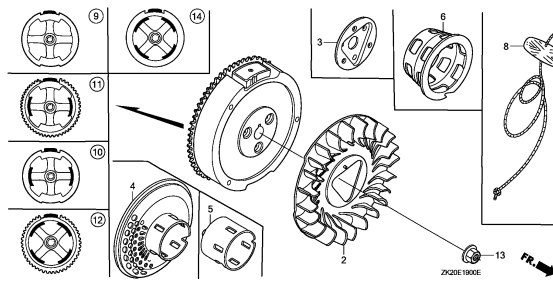

ZK30E1900E

E-20

IGNITION COIL

2-B 9

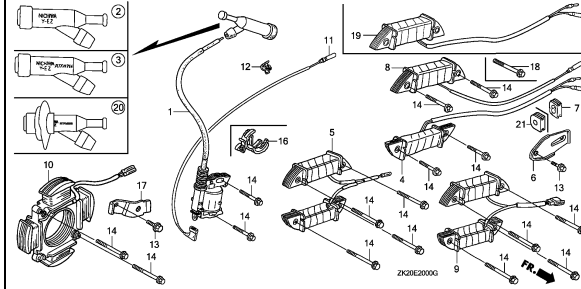

ZK30E2000G

E-21

STARTER MOTOR

2-B15

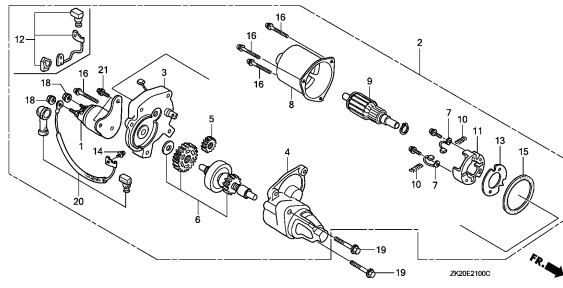

ZK30E2100C

E-22

CONTROL

2-C 3

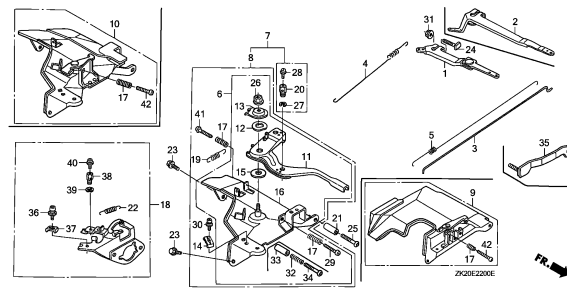

ZK30E2200E

E-23

CONTROL BOX(1)

2-C16

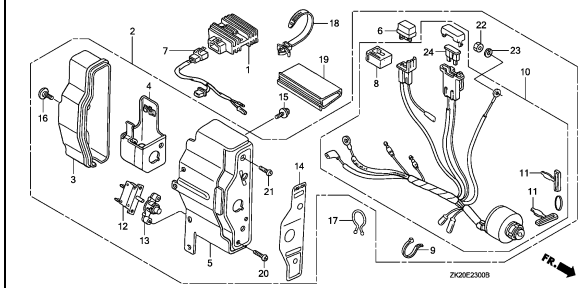

ZK30E2300B

2

ENGINE GROUP

D14

E-26-2

REDUCTION(1/6)(3)

2-E 7

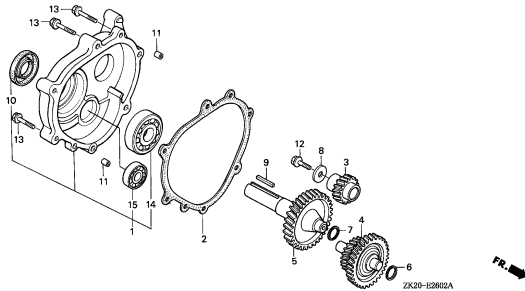

E-28

LABEL

2-E 8

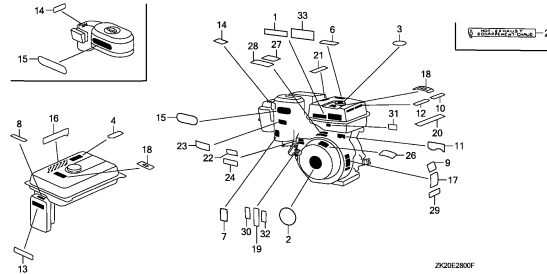

E-29

TOOL(1)

2-E15

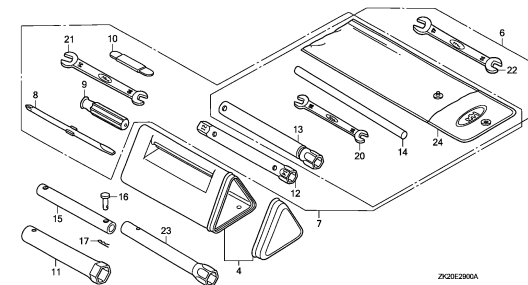

E-29-1

TOOL(2)

2-F 1

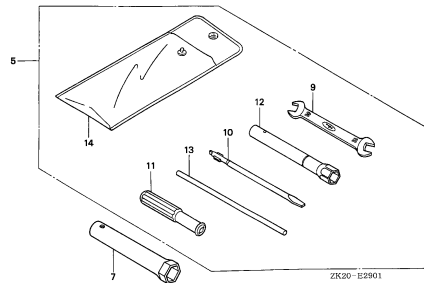

E-40

CONTROL CASE

2-F 2

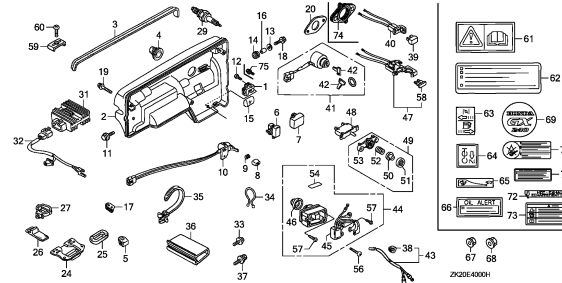

E-40-1

TRANSMISSION CASE

2-F 6

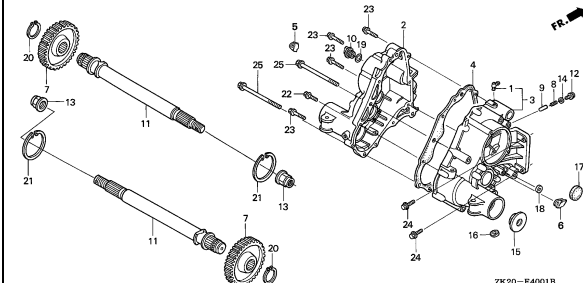

E-40-2

TRANSMISSION

2-F 7

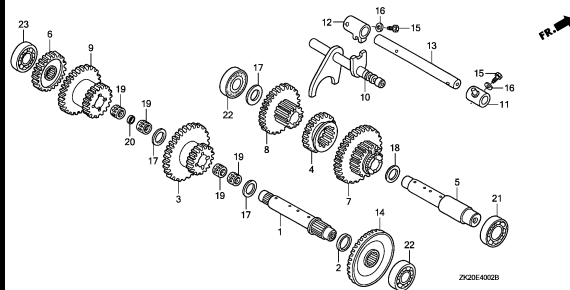

E-40-3

SIDE CLUTCH

2-F 8

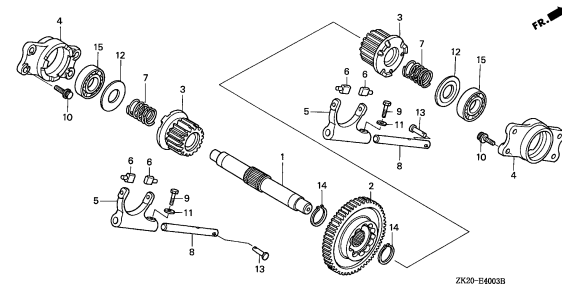

E-40-4

BEVEL GEAR

2-F 9

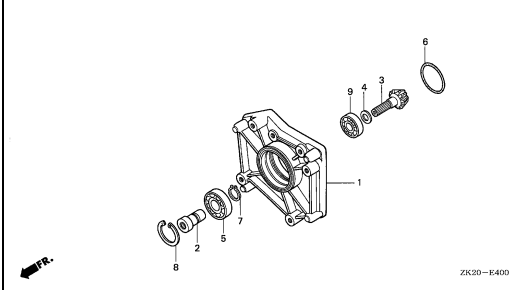

ENGINE GROUP

D15

E-40-5

OTHER PARTS

2-F10

EOP-1

GASKET KIT

2-F11

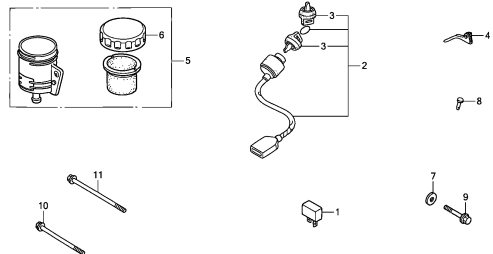

ZK00E4005A

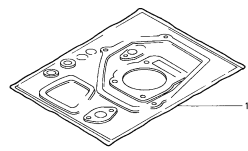

HENG-K0003

2

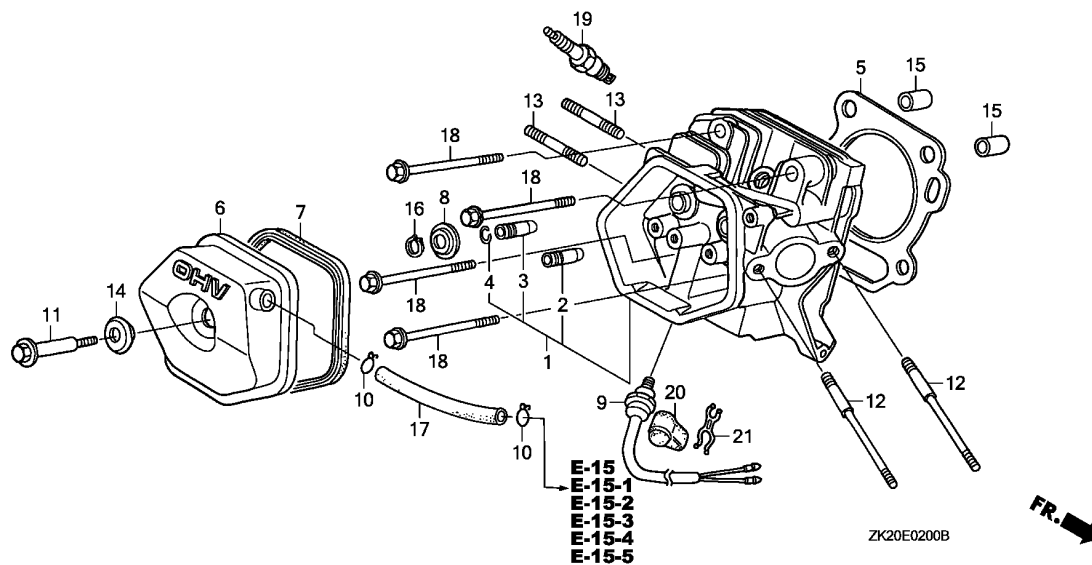

Ref. No.	L.O.N.	(Relative ref. Number) Description	F.R.T.
1	1111N3	HEAD, CYLINDERINCLUDES: Valve clearance adjustment and reface	0.9
2	1111E9	GUIDE, INTAKE VALVEINCLUDES: Valve clearance adjustment	0.8
	1111E9E	.Replace intake and exhaust all add	0.2
3	1111E8	GUIDE, EXHAUST VALVEINCLUDES: Valve clearance adjustment	0.8
	1111E8E	.Replace intake and exhaust all add	0.2
5	1111N4	GASKET, CYLINDER HEAD	0.5
6	1111D5	COVER, CYLINDER HEAD AND/OR PACKING, HEAD COVER	0.1
9	6171C4	SWITCH, CYLINDER HEAD THERMO ..	0.2
17	1111K5	TUBE, BREATHER	0.1
19	6141C1	PLUG, SPARK	0.1
		.INCLUDES: Spark plug check	

Ref. No.	Part No.	Description	Reqd. QTY			Serial No.	Parts catalogue code
			(1)	(2)	(3)		
1	12200-ZH9-000	HEAD COMP., CYLINDER	1	1	-	-----	EDN,EDN2,EDS,EDS1,EDS2,EDS3,EDS5,EDS6,EDT1,EDT2,EDT6,ED2,ED3,ED4,ED5,EN,EN2,ES,ES1,ES3,ET,ETS,ETX,HA,HAQ,HA2,HH,HHQ4,HTX,HX,HXQ4,LD,LDB1,LDB3,LH,LHE,LHE4,LHZ,LJ,LJG,LJG1,LJS,LK,LKS,LM9,LNJ,LNZ,LP,LSS4,LSS5,LSX,LT,LW,LX,LXQ4,LXZ,LX2,L1,PA,PAE,PA2,PMT2,PX,P1,QA,QAB2,QAQ,QAQ2,QAG,QAG2,QAQ,QAQ4,QAR2,QA2,QC12,QD,QDA,QE,QH,QHC,QHE,QHP1,QHQ4,QHZ,QAQ2,QMH,QMX2,QP,QT,QTC2,QW24,QX,QXB,QXB7,QXC,QXC9,QXE,QXEB,QXE4,QXQ4,QXU,Q1,RA,RA2,RD,RH,RHE,RHE4,RHQ4,RJ,RSC2,RSS1,RTB2,RX,RXQ4,R1,SD,SDB1,SDB3,SE,SH,SHE,SHEZ,SHW,SJ,SJC,SJC1,SJC5,SJG,SJP,SK,SMS,SMX2,SNC1,SNE1,SNR,STP,STQ,SW,SWE,SX,SXB,SXE,SXEB,SXE4,SXQ4,SXU,S1,VA,VAH1,VA2,VDG2,VH,VH12,VMT2,VMX,VNG,VSB1,VTA,VTA2,VTE2,VWC2,VX,VXB,VXB7,VXE,VXEB,VXQ4,VXQ7,VXU,VXU1,V1,WH,WJ,WKA,WKD6,WKT2,WKT4,W1
	12200-ZH9-800	-	-	1	-----	VXP,VXQP
	12200-ZH9-405	1	1	-	-----	EDN2/A,EDS1/A,EDS2/A,EDS6/A,EDT1/A,EDT3,EDT6/A,ED2/A,ED4/A,ED5/A,EN2/A,ES1/A,ES2,ES3/A,HA2/A,HHQ4/A,HX/A,HXQ4/A,LH/A,LHE4/A,LJ/A,LJG/A,LJS/A,LKS/A,LP/A,LSS5/A,LSX/A,LT/A,LX/A,LXF,LXQ4/A,LX2/A,L1/A,PA2/A,PMT2/A,PX/A,QAB2/A,QAQ2/A,QAG/A,QAQ/A,QAQ2/A,QAR2/A,QA2/A,QA2/A,QA2/A,QD/A,QA/A,QH/A,QHB2,QHP1/A,QHQ4/A,QMH/A,QA/A,QT/A,QTC2/A,QW24,QX/A,QXB7/A,QXC/A,QXC9/A,QXE/A,QXE4/A,QXQ4/A,QXU/A,Q1/A,RA2/A,RD/A,RHQ4/A,RJ/A,RSS1/A,RTB2/A,RX/A,RXQ4/A,R1/A,SD/A,SDB3/A,SE/A,SHW/A,SJ/A,SJC1/A,SJC5/A,SJG/A,SMS/A,SMX2/A,SNR/A,STP/A,STQ/A,SX/A,SXE4/A,SXQ4/A,SXU/A,S1/A,VA2/A,VDG2/A,VH/A,VH12/A,VMT2,VSB1/A,VS3,VS4,VTA2/A,VWC2/A,VX/A,VXB/A,VXB7/A,VXE/A,VXEB/A,VXQ4/A,VXQ7/A,VXU/A,VXU1/A,WJ/A,WKD6/A,WKT2/A,WKT4/A,WKM,W1/A
	12200-ZH9-406	-	-	1	-----	VXP/A
2	12204-ZE2-306	GUIDE, IN. VALVE (O.S.)	1	1	1	-----	
3	12205-ZE2-305	GUIDE, EX. VALVE (O.S.)	1	1	1	-----	
4	12216-ZE2-300	CLIP, VALVE GUIDE	1	1	1	-----	
5	12251-ZE2-800	GASKET, CYLINDER HEAD	1	(1)	1	-----	

Ref. No.	Part No.	Description	Reqd. QTY			Serial No.	Parts catalogue code
			(1)	(2)	(3)		
6	12310-ZE2-010	COVER COMP., HEAD	1	(1)	-	3146326	EDN,EDS,ED2,ED3,ED4,ED5,EN,ES,ES1,ES3,ET,ETS,ETX,HA,HH,HX,LD,LH,LHE,LJ,LK,LKS,LM9,LNJ,LP,LW,LX,LXZ,L1,PA,PX,P1,QA,QAE,QD,QE,QH,QHE,QP,QT,QX,QXB,QXE,QXEB,Q1,RA,RD,RH,RHE,RJ,RX,R1,SD,SE,SH,SHE,SHEZ,SJ,SJP,SK,SNR,STP,STQ,SW,SWE,SX,SXB,SXE,SXEB,S1,VA,VAH1,VH,VNG,VTA,VX,VXB,VXE,VXEB,V1,WH,WJ,WKA,W1
	12310-ZE3-790	COVER COMP., HEAD (BREATHER TUBE JOINT)	1	-	-		QDA
	12310-ZE2-020	COVER COMP., HEAD	1	(1)	-	3139634	HAQ,L1,P1,QAQ,QHC,QXC,Q1,R1,S1,V1,W1
			1	(1)	-		EDN2,EDN2/A,EDS1,EDS1/A,EDS2,EDS2/A,EDS3,EDS3/A,EDT1,EDT1/A,EDT2,EDT3,EDT6,EDT6/A,ED2/A,ED4/A,ED5/A,EN2,EN2/A,ES1/A,ES2,ES3/A,HA2,HA2/A,HHQ4,HHQ4/A,HTX,HX/A,HXQ4,HXQ4/A,LDB1,LDB3,LH/A,LHE4,LHE4/A,LHZ,LJ/A,LJG,LJG/A,LJG1,LJS,LJS/A,LKS/A,LNZ,LP/A,LSS5,LSS5/A,LSX,LSX/A,LT,LT/A,LX/A,LXF,LXQ4,LXQ4/A,LX2,LX2/A,L1/A,PAE,PA2,PA2/A,PMT2,PMT2/A,PX/A,QAB2,QAB2/A,QAE2,QAE2/A,QAG,QAG/A,QAG2,QAG2/A,QAQ4,QAR2,QAR2/A,QA2,QA2/A,QC12,QC12/A,QD/A,QE/A,QH/A,QHB2,QHP1,QHP1/A,QHQ4,QHQ4/A,QHZ,QKA2,QMH,QMH/A,QMX2,QP/A,QT/A,QTC2,QTC2/A,QW24,QX/A,QXB7,QXB7/A,QXE/A,QXE4,QXE4/A,QXQ4,QXQ4/A,QXU,QXU/A,Q1/A,RA2,RA2/A,RD/A,RHE4,RHQ4,RHQ4/A,RJ/A,RSC2,RSS1,RSS1/A,RTB2,RTB2/A,RX/A,RXQ4,RXQ4/A,R1/A,SD/A,SDB1,SDB3,SDB3/A,SE/A,SHW,SHW/A,SJ/A,SJC,SJC1,SJC1/A,SJC5,SJC5/A,SJG,SJG/A,SMS,SMS/A,SMX2,SMX2/A,SNC1,SNE1,SNR/A,STP/A,STQ/A,SX/A,SXE4,SXE4/A,SXQ4,SXQ4/A,SXU,SXU/A,S1/A,VA2,VA2/A,VDG2,VDG2/A,VH/A,VH12,VH12/A,VMT2,VMX,VSB1,VSB1/A,VS3,VS4,VTA2,VTA2/A,VTE2,VWC2,VWC2/A,VX/A,VXB/A,VXB7,VXB7/A,VXE/A,VXEB/A,VXQ4,VXQ4/A,VXQ7,VXQ7/A,VXU,VXU/A,VXU1,VXU1/A,WJ/A,WKD6,WKD6/A,WKT2,WKT2/A,WKT4,WKT4/A,WMK,W1/A
			1	(1)	-	3146327	EDN,EDS,ED2,ED3,ED4,ED5,EN,ES,ES1,ES3,ET,ETS,ETX,HA,HH,HX,LD,LH,LHE,LJ,LK,LKS,LM9,LNJ,LP,LW,LX,LXZ,L1,PA,PX,P1,QA,QAE,QD,QE,QH,QHE,QP,QT,QX,QXB,QXE,QXEB,Q1,RA,RD,RH,RHE,RJ,RX,R1,SD,SE,SH,SHE,SHEZ,SJ,SJP,SK,SNR,STP,STQ,SW,SWE,SX,SXB,SXE,SXEB,S1,VA,VAH1,VH,VNG,VTA,VX,VXB,VXE,VXEB,V1,WH,WJ,WKA,W1
	12310-ZE3-791	COVER COMP., HEAD (BREATHER TUBE JOINT)	-	-	1		
			1	(1)	-		EDS5,LSS4,L1/A,QXC/A,QXC9,QXC9/A,Q1/A,R1/A,S1/A,W1/A
			1	(1)	-	3139635	HAQ,L1,P1,QAQ,QHC,QXC,Q1,R1,S1,V1,W1
7	12391-ZE2-020	PACKING, HEAD COVER	1	(1)	1		
8	14775-ZE2-010	SEAT, VALVE SPRING	1	1	1		
9	16500-ZE2-702	SWITCH, THERMO	1	-	-		EDS3,EDS5,WKA
10	17316-611-000	CLIP, BREATHER TUBE	2	-	-		HAQ,LSS4,QAQ,QHC,QXC,QXC/A,QXC9,QXC9/A
			-	(2)	-		
11	90014-ZE2-000	BOLT, HEAD COVER	1	1	1		
12	90042-ZB7-000	BOLT, STUD, 8X111	2	-	-		EDS5
	90042-ZE2-T00	BOLT, STUD, 8X115	2	-	-		LKS,LKS/A



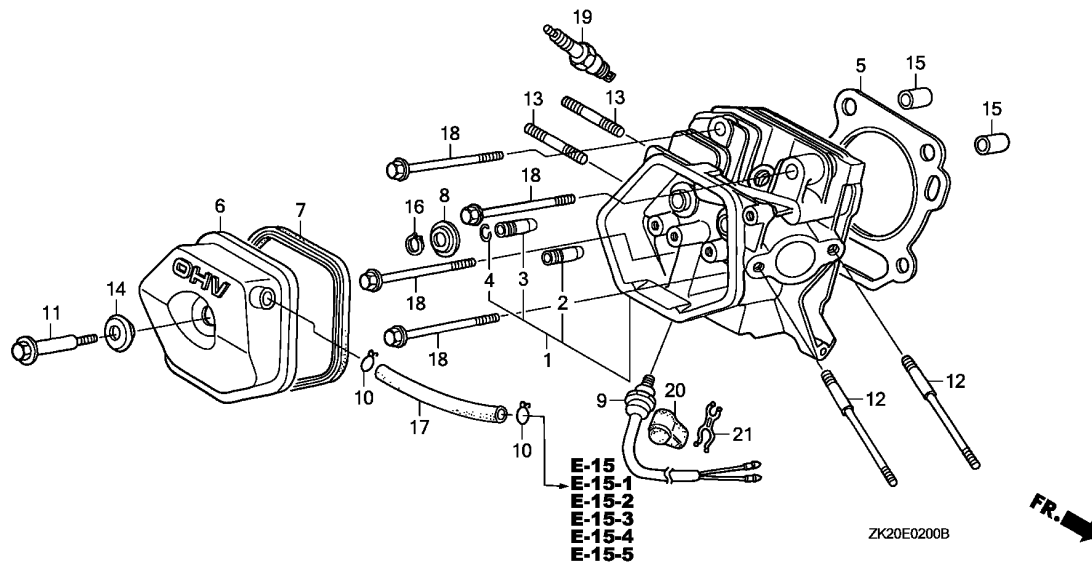

Ref. No.	Part No.	Description	Reqd. QTY			Serial No.	Parts catalogue code
			(1)	(2)	(3)		
12)	90042-ZE2-000	BOLT, STUD, 8X123	2	-	-	-----	ED3,ED4,ED4/A,ED5,ED5/A,EN,ES,ES1,ES1/A,ES2,ET,ETS,ETX,HA,HAQ,HA2,HA2/A,HH,HHQ4,HHQ4/A,HTX,HX,HX/A,HXQ4,HXQ4/A,LD,LDB1,LDB3,LH,LH/A,LHE,LHE4,LHE4/A,LHZ,LJ,LJ/A,LJG,LJG/A,LJG1,LJS,LJS/A,LK,LM9,LNJ,LNZ,LP,LP/A,LSS4,LSS5,LSS5/A,LSX,LSX/A,LT,LT/A,LW,LX,LX/A,LXF,LXQ4,LXQ4/A,LXZ,LX2,LX2/A,PA,PAE,PA2,PA2/A,PMT2,PMT2/A,PX,PX/A,QA,QAB2,QAB2/A,QAE,QAE2,QAE2/A,QAG,QAG/A,QAG2,QAG2/A,QAQ,QAQ4,QAR2,QAR2/A,QA2,QA2/A,QC12,QC12/A,QD,QD/A,QDA,QE,QE/A,QH,QH/A,QHB2,QHC,QHE,QHP1,QHP1/A,QHQ4,QHQ4/A,QHZ,QKA2,QMH,QMH/A,QMX2,QP,QP/A,QT,QT/A,QTC2,QTC2/A,QW24,QX,QX/A,QXB,QXB7,QXB7/A,QXC,QXC/A,QXC9,QXC9/A,QXE,QXE/A,QXEB,QXE4,QXE4/A,QXQ4,QXQ4/A,QXU,QXU/A,RA,RA2,RA2/A,RD,RD/A,RH,RHE,RHE4,RHQ4,RHQ4/A,RJ,RJ/A,RSC2,RSS1,RSS1/A,RTB2,RTB2/A,RX,RX/A,RXQ4,RXQ4/A,SD,SD/A,SDB1,SDB3,SDB3/A,SE,SE/A,SH,SHE,SHEZ,SHW,SHW/A,SJ,SJ/A,SJC,SJC1,SJC1/A,SJC5,SJC5/A,SJG,SJG/A,SJP,SK,SMS,SMS/A,SMX2,SMX2/A,SNC1,SNE1,SNR,SNR/A,STP,STP/A,STQ,STQ/A,SW,SWE,SX,SX/A,SXB,SXE,SXEB,SXE4,SXE4/A,SXQ4,SXQ4/A,SXU,SXU/A,VA,VAH1,VA2,VA2/A,VDG2,VDG2/A,VH,VH/A,VH12,VH12/A,VMX,VNG,VTA,VTA2/VTA2/A,VVC2,VVC2/A,VX,VX/A,VXB,VXB/A,VXB7,VXB7/A,VXE,VXE/A,VXEB,VXEB/A,VXQ4,VXQ4/A,VXQ7,VXQ7/A,VXU,VXU/A,VXU1,VXU1/A,WH,WJ,WJ/A,WKD6,WKD6/A,WKT2,WKT2/A,WKT4,WKT4/A,WMK
	90042-ZE2-700	BOLT, STUD, 8X98	2	-	2	-----	EDN,EDN2,EDN2/A,EDS,EDS1,EDS1/A,EDS2,EDS2/A,EDS3,EDS6,EDS6/A,EDT1,EDT1/A,EDT2,EDT3,EDT6,EDT6/A,ED2,ED2/A,EN2,EN2/A,ES3,ES3/A,VMT2,VS1,VS1/A,VS3,VS4,VTE2,WKA

Ref. No.	Part No.	Description	Reqd. QTY			Serial No.	Parts catalogue code
			(1)	(2)	(3)		
13	90047-ZE2-000	BOLT, STUD, 8X47	2	2	-	-----	EDS,EN,ET,ETS,ETX,HA,HAQ,HH,LDB1,LK,LNJ,LW,LXZ,PA,PAE,P1,QA,QAE,QAQ,QDA,QHC,QHE,QKA2,QXB,QXEB,RA,RH,RHE,RHE4,SH,SHEZ,SK,SNC1,SNE1,SW,SWE,AXB,SXE,SXEB,VA,VAH1,VNG,VTA,VTE2,V1,WH,WKA
			2	2	-	-----	3844352 EDN,EDN2,EDS1,EDS2,EDS3,EDT1,EDT2,ED2,ED3,ED4,ED5,ES,ES1,ES3,HA2,HHQ4,HTX,HX,HXQ4,LD,LDB3,LH,LHE,LHE4,LHZ,LJ,LJG,LJG1,LKS,LNZ,LP,LSS4,LSS5,LSX,LX,LXQ4,LX2,L1,PA2,PMT2,PX,QAE2,QAG2,QAQ4,QAR2,QA2,QC12,QD,QE,QH,QHP1,QHQ4,QHZ,QMH,QMX2,QP,QT,QX,QXC,QXC9,QXE,QXE4,QXQ4,QXU,Q1,RA2,RD,RHQ4,RJ,RSC2,RSS1,RTB2,RX,RXQ4,R1,SD,SDB1,SDB3,SE,SHE,SJ,SJC,SJC1,SJC5,SJG,SMX2,SNR,STP,STQ,SW,SXE4,XXQ4,XXU,S1,VA2,VH,VH12,VMX,VSB1,VWC2,VX,VXB,VXE,VXEB,VXQ4,VXU,VXU1,WJ,WKT2,WKT4,W1
	92900-08032-0E	BOLT, STUD, 8X32	2	2	-	-----	EDN2/A,EDS1/A,EDS2/A,EDS6,EDS6/A,EDT1/A,EDT3,EDT6,EDT6/A,ED2/A,ED4/A,ED5/A,EN2,EN2/A,ES1/A,ES2,ES3/A,HA2/A,HHQ4/A,HX/A,HXQ4/A,LH/A,LHE4/A,LJ/A,LJG/A,LJS,LJS/A,LKS/A,LP/A,LSS5/A,LSX/A,LT,LT/A,LX/A,LXF,LXQ4/A,LX2/A,L1/A,PA2/A,PMT2/A,PX/A,QAB2,QAB2/A,QAE2/A,QAG,QAG/A,QAG2/A,QAR2/A,QA2/A,QC12/A,QD/A,QE/A,QH/A,QHB2,QHP1/A,QHQ4/A,QMH/A,QP/A,QT/A,QTC2,QTC2/A,QW24,QX/A,QXB7,QXB7/A,QXC/A,QXC9/A,QXE/A,QXE4/A,QXQ4/A,QXU/A,Q1/A,RA2/A,RD/A,RHQ4/A,RJ/A,RSS1/A,RTB2/A,RX/A,RXQ4/A,R1/A,SD/A,SDB3/A,SE/A,SHW,SHW/A,SJ/A,SJC1/A,SJC5/A,SJG/A,SMX2/A,SNR/A,STP/A,STQ/A,SW/A,SXE4/A,XXQ4/A,XXU/A,S1/A,VA2/A,VDG2,VDG2/A,VH/A,VH12/A,VSB1/A,VS3,VS4,VT2,VT2/A,VWC2/A,VX/A,VXB/A,VXB7,VXB7/A,VXE/A,VXEB/A,VXQ4/A,VXQ7,VXQ7/A,VXU/A,VXU1/A,WJ/A,WKD6,WKD6/A,WKT2/A,WKT4/A,WMK,W1/A
			2	2	-	3844353	----- EDN,EDN2,EDS1,EDS2,EDS3,EDT1,EDT2,ED2,ED3,ED4,ED5,ES,ES1,ES3,HA2,HHQ4,HTX,HX,HXQ4,LD,LDB3,LH,LHE,LHE4,LHZ,LJ,LJG,LJG1,LKS,LNZ,LP,LSS4,LSS5,LSX,LX,LXQ4,LX2,L1,PA2,PMT2,PX,QAE2,QAG2,QAQ4,QAR2,QA2,QC12,QD,QE,QH,QHP1,QHQ4,QHZ,QMH,QMX2,QP,QT,QX,QXC,QXC9,QXE,QXE4,QXQ4,QXU,Q1,RA2,RD,RHQ4,RJ,RSC2,RSS1,RTB2,RX,RXQ4,R1,SD,SDB1,SDB3,SE,SHE,SJ,SJC,SJC1,SJC5,SJG,SMX2,SNR,STP,STQ,SW,SXE4,XXQ4,XXU,S1,VA2,VH,VH12,VMX,VSB1,VWC2,VX,VXB,VXE,VXEB,VXQ4,VXU,VXU1,WJ,WKT2,WKT4,W1
	90012-KM9-000	BOLT, STUD, 8X34	-	-	2		
	92900-08060-0E	BOLT, STUD, 8X60	2	-	-	-----	EDS5,SJP,SMS,SMS/A
	90047-ZE3-791	BOLT, STUD, 8X40	2	-	-	-----	LM9
	14 90441-ZE2-010	WASHER COMP., HEAD COVER	1	1	1		VMT2
	15 94301-12200	DOWEL PIN, 12X20	2	2	2		
	16 94510-11000	CIRCLIP, EXTERNAL, 11MM	1	1	-	-----	LJ,LK,LNJ,L1,Q1,RJ,R1,SJ,SJP,SK,STP,STQ,S1,WJ,WKA,W1
	17 95005-11105-30	TUBE, 11X105(95005-11001-30M)	1	(1)	-	-----	3454867 ED3,ED4,ED5,EN,ES,ES1,ET,ETS,ETX,HA,HA2,HH,HHQ4,HTX,HX,HXQ4,LD,LDB1,LDB3,LH,LHE,LHE4,LJ,LJG,LK,LKS,LM9,LNJ,LNZ,LP,LW,LX,LXQ4,LX2,L1,PA,PAE,PA2,PMT2,PX,P1,QA,QAE,QAE2,QAG2,QAQ4,QAR2,QA2,QD,QE,QH,QHE,QHQ4,QKA2,QP,QT,QX,QXB,QXE,QXEB,QXE4,QXQ4,Q1,RA,RA2,RD,RH,RHE,RHE4,RHQ4,RJ,RSC2,RTB2,RX,RXQ4,R1,SD,SDB1,SDB3,SE,SH,SHE,SHEZ,SJ,SJC,SJG,SJP,SK,SMS,SMX2,SNC1,SNE1,SNR,STP,STQ,SW,SWE,SW,SXE,SXE4,SXEB,SXE4,XXQ4,VA,VAH1,VA2,VH,VH12,VNG,VTA,VWC2,VX,VXB,VXE,VXEB,VXQ4,VXU,V1,WH,WJ,WKT2,W1
			1	-	-	-----	QDA
			-	1	-	-----	3454867 S1
			-	-	1	-----	1000005 VXP,VXQP



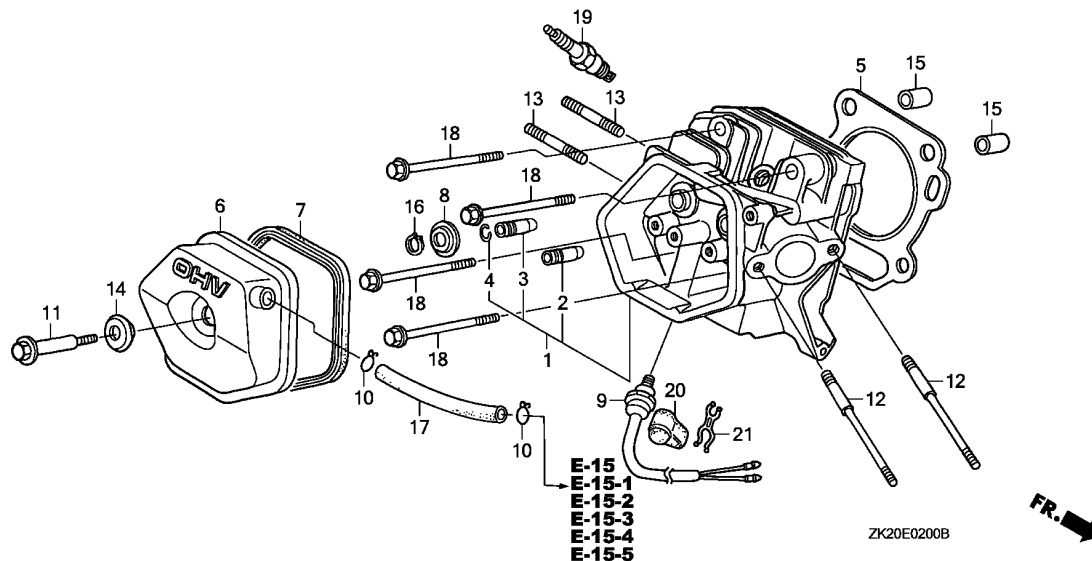

Ref. No.	Part No.	Description	Reqd. QTY			Serial No.	Parts catalogue code	
			GX240K1					
			(1)	(2)	(3)			
17)	95005-11100-30	TUBE, 11X100(95005-11001-30M)	1	(1)	1	-----	ED4/A,ED5/A,ES1/A,ES2,HA2/A,HHQ4/A,HX/A,HXQ4/A,LH/A,LHE4/A,LHZ LJ/A,LJG/A,LJG1/LJS,LJS/A,LP/A,LSS5,LSS5/A,LSX,LSX/A,LT,LT/A,LX/A LXF,LXQ4/A,LX2/A,L1/A,PA2/A,PMT2/A,PX/A,QAB2,QAB2/A,QAE2/A,QAG QAG/A,QAG2/A,QAR2/A,QA2/A,QC12,QC12/A,QD/A,QE/A,QH/A,QHB2,QHP1 QHP1/A,QHQ4/A,QHZ,QMH,QMH/A,QMX2,QP/A,QT/A,QTC2,QTC2/A,QW24,QX/A QXB7,QXB7/A,QXE/A,QXE4/A,QXQ4/A,QXU,QXU/A,Q1/A,RA2/A,RD/A,RHQ4/A RJ/A,RSS1,RSS1/A,RTB2/A,RX/A,RXQ4/A,R1/A,SD/A,SDB3/A,SE/A,SHW SHW/A,SJ/A,SJC1,SJC1/A,SJC5,SJC5/A,SJG/A,SMS/A,SMX2/A,SNR/A,STP/A STQ/A,SX/A,SXE4/A,SXQ4/A,SXU,SXU/A,S1/A,VA2/A,VDG2,VDG2/A,VH/A VH12/A,VMX,VTA2,VTA2/A,VWC2/A,VX/A,VXB/A,VXB7,VXB7/A,VXE/A,VXEB/A VXP/A,VXQ4/A,VXQ7,VXQ7/A,VXU/A,VXU1,VXU1/A,WJ/A,WKD6,WKD6/A WKT2/A,WKT4,WKT4/A,WMK,W1/A	
			1	(1)	-	3454868	-----	ED3,ED4,ED5,EN,ES,ES1,ET,ETS,ETX,HA,HA2,HH,HHQ4,HTX,HX,HXQ4,LD LDB1,LDB3,LH,LHE,LHE4,LJ,LJG,LK,LKS,LM9,LNJ,LNZ,LP,LW,LX,LXQ4,LXZ LX2,L1,PA,PAE,PA2,PMT2,PX,P1,QA,QAE,QAE2,QAG2,QAQ4,QAR2,QA2,QD,QE QH,QHE,QHQ4,QKA2,QP,QT,QX,QXB,QXE,QXEB,QXE4,QXQ4,Q1,RA,RA2,RD,RH RHE,RHE4,RHQ4,RJ,RSC2,RTB2,RX,RXQ4,R1,SD,SDB1,SDB3,SE,SH,SHE,SHEZ SJ,SJC,SJG,SJP,SK,SMS,SMX2,SNC1,SNE1,SNR,STP,STQ,SW,SWE,SX,SXB SXE,SXEB,SXE4,SXQ4,VA,VAH1,VA2,VH,VH12,VNG,VTA,VWC2,VX,VXB,VXE VXEB,VXQ4,VXU,V1,WH,WJ,WKT2,W1
			-	1	-	3454868	-----	S1
			-	-	1	1000006	-----	VXP,VXQP
	12315-ZE3-840	TUBE, BREATHER	1	(1)	-	-----	-----	HAQ,LSS4,L1,L1/A,P1,QAQ,QHC,QXC,QXC/A,QXC9,QXC9/A,Q1,Q1/A,R1,R1/A V1,W1,W1/A

Ref. No.	Part No.	Description	Reqd. QTY			Serial No.	Parts catalogue code
			(1)	(2)	(3)		
18	95725-10080-00	BOLT, FLANGE, 10X80	4	4	-		EDN,EDN2,EDN2/A,EDS,EDS1,EDS2,EDS2/A,EDS3,EDS5,EDS6,EDS6/A,EDT1 EDT2,EDT6,EDT6/A,ED2,ED2/A,ED3,ED4,ED4/A,ED5,EN,EN2,EN2/A,ES,ES1 ES3,ET,ETS,ETX,HA,HAQ,HA2,HA2/A,HH,HHQ4,HHQ4/A,HTX,HX,HXQ4,HXQ4/A LD,LDB1,LDB3,LH,LHE,LHE4,LHE4/A,LHZ,LJ,LJG,LJG1,LJS,LK,LM9 LNJ,LNZ,LP,LSS4,LSS5,LSS5/A,LSX,LT,LW,LX,LXQ4,LXQ4/A,LXZ,LX2 LX2/A,L1,PA,PAE,PA2,PA2/A,PMT2,PMT2/A,PX,P1,QA,QAB2,QAB2/A,QA QAE2,QA2/A,QAG,QAG/A,QAG2,QAG2/A,QAQ,QAQ4,QAR2,QAR2/A,QA2,QA2/A QC12,QC12/A,QD,QDA,QE,QE/A,QH,QHB2,QHC,QHE,QHP1,QHQ4,QHQ4/A,QHZ QKA2,QMH,QMX2,QP,QT,QTC2,QTC2/A,QW24,QX,QXB,QXB7,QXB7/A,QXC,QXC9 QXC9/A,QXE,QXEB,QXE4,QXE4/A,QXQ4,QXQ4/A,QXU,QXU/A,Q1,RA,RA2,RA2/A RD,RH,RHE,RHE4,RHQ4,RHQ4/A,RJ,RSC2,RSS1,RTB2,RTB2/A,RX,RXQ4 RXQ4/A,R1,SD,SDB1,SDB3,SE,SE/A,SH,SHE,SHEZ,SHW,SJ,SJC,SJC1,SJC5 SJG,SJP,SK,SMS,SMX2,SMX2/A,SNC1,SNE1,SNR,STP,STQ,STQ/A,SW,SWE,SX SXB,SXE,SXEB,SXE4,SXE4/A,SXQ4,SXQ4/A,SXU,SXU/A,S1,VA,VAH1,VA2 VA2/A,VDG2,VDG2/A,VH,VH12,VH12/A,VMT2,VMX,VNG,VSB1,VTA,VTA2 VTA2/A,VTE2,VWC2,VWC2/A,VX,VXB,VXB/A,VXB7,VXB7/A,VXE,VXEB,VXQ4 VXQ4/A,VXQ7,VXQ7/A,VXU,VXU1,VXU1/A,V1,WH,WJ,WKA,WKD6,WKD6/A,WKT2 WKT2/A,WKT4,WKT4/A,W1
			4	4	-	4847591	EDS1/A,EDT1/A,ED5/A,ES1/A,ES3/A,HX/A,LH/A,LJ/A,LJG/A,LJS/A,LKS/A LP/A,LSX/A,LT/A,LX/A,LXF,L1/A,PX/A,QD/A,QH/A,QHP1/A,QMH/A,QP/A QT/A,QX/A,QXC/A,QXE/A,Q1/A,RD/A,RJ/A,RSS1/A,RX/A,R1/A,SD/A,SDB3/A SHW/A,SJ/A,SJC1/A,SJC5/A,SJG/A,SMS/A,SNR/A,STP/A,SX/A,S1/A,VH/A VSB1/A,VS3,VX/A,VXE/A,VXEB/A,VXU/A,WJ/A,W1/A
	95701-10080-00	-	-	4	4847592	EDS1/A,EDT1/A,ED5/A,ES1/A,ES3/A,HX/A,LH/A,LJ/A,LJG/A,LJS/A,LKS/A LP/A,LSX/A,LT/A,LX/A,LXF,L1/A,PX/A,QD/A,QH/A,QHP1/A,QMH/A,QP/A QT/A,QX/A,QXC/A,QXE/A,Q1/A,RD/A,RJ/A,RSS1/A,RX/A,R1/A,SD/A,SDB3/A SHW/A,SJ/A,SJC1/A,SJC5/A,SJG/A,SMS/A,SNR/A,STP/A,SX/A,S1/A,VH/A VSB1/A,VS3,VX/A,VXE/A,VXEB/A,VXU/A,WJ/A,W1/A
19	98079-55841	PLUG, SPARK (BP5ES) (NGK)	4	-	-		EDT3,ES2,VS4,WMK
			1	-	-		ES2,WKA
			1	-	-	3860624	VSB1
			(1)	-	-		EN,ES,ET,ETS,ETX,LD,LDB1,LDB3,LJ,LJ/A,LJG,LJG/A,LJG1,LJS,LJS/A,LK LM9,LNJ,LNZ,LSS5,LSS5/A,LT,LT/A,QD,QD/A,QDA,RD,RD/A,RJ,RJ/A,RSS1 RSS1/A,SD,SD/A,SDB1,SDB3,SDB3/A,SJ,SJ/A,SJC,SJC1,SJC1/A,SJC5 SJC5/A,SJG,SJG/A,SK,SMS,SMS/A,WJ,WJ/A,WMK
			(1)	-	-	3860624	LSX,SNR
	98079-55854	PLUG, SPARK (W16EP-U) (DENSO)	-	(1)	-		
			(1)	-	-		LJ,LJ/A,LJG,LJG/A,LJS,LJS/A,LSS5,LSS5/A,LT,LT/A,QD,QD/A,QT,QT/A RD,RD/A,RJ,RJ/A,RSS1,RSS1/A,SD,SD/A,SDB3,SDB3/A,SJ,SJ/A,SJC1 SJC1/A,SJC5,SJC5/A,SJG,SJG/A,SMS,SMS/A,WJ,WJ/A,WMK



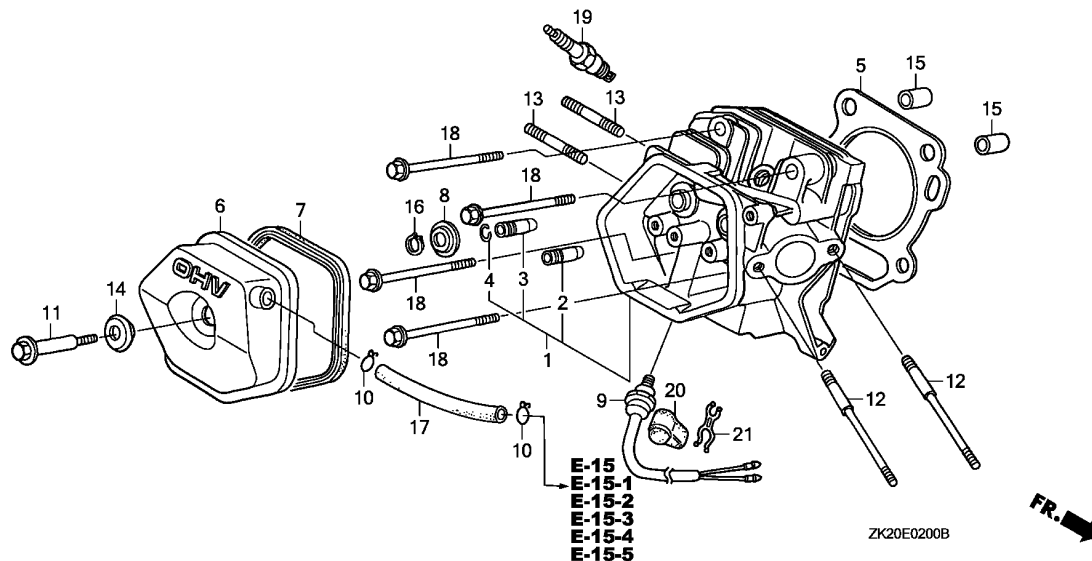

Ref. No.	Part No.	Description	Reqd. QTY			Serial No.	Parts catalogue code
			GX240K1	(1)	(2)		
19)	98079-55855	PLUG, SPARK (W16EPR-U) (DENSO)	1	-	-	-----	EDN,EDN2,EDN2/A,EDS,EDS1,EDS1/A,EDS2,EDS2/A,EDS3,EDS5,EDS6,EDS6/A,EDT1,EDT1/A,EDT2,EDT3,EDT6,EDT6/A,ED2,ED2/A,EN2,EN2/A,ES3,ES3/A,QW24,VMT2,VSB1,VSB1/A,VS3,VS4,VTE2,WKA
			(1)	-	-	-----	ED3,ED4,ED4/A,ED5,ED5/A,EN,ES,ES1,ES1/A,ES2,ET,ETS,ETX,HA,HAQ,HA2,HA2/A,HH,HHQ4,HHQ4/A,HTX,HX,HX/A,HXQ4,HXQ4/A,LD,LDB1,LDB3,LH,LH/A,LHE,LHE4,LHE4/A,LHZ,LJG1,LK,LKS,LKS/A,LM9,LNJ,LNZ,LP,LP/A,LSS4,LSX,LSX/A,LW,LX,LX/A,LXF,LXQ4,LXQ4/A,LXZ,LX2,LX2/A,PA,PAE,PA2,PA2/A,PMT2,PMT2/A,PX,PX/A,QA,QAB2,QAB2/A,QAE,QAE2,QAE2/A,QAG,QAG/A,QAG2,QAG2/A,QAQ,QAQ4,QAR2,QAR2/A,QA2,QA2/A,QC12,QC12/A,QDA,QE,QE/A,QH,QH/A,QHB2,QHC,QHE,QHP1,QHP1/A,QHQ4,QHQ4/A,QHZ,QKA2,QMH/A,QMX2,QP,QP/A,QTC2,QTC2/A,QX,QX/A,QXB,QXB7,QXB7/A,QXC,QXC/A,QXC9,QXC9/A,QXE,QXE/A,QXEB,QXE4,QXE4/A,QXQ4,QXQ4/A,QXU,QXU/A,RA,RA2,RA2/A,RH,RHE,RHE4,RHQ4,RHQ4/A,RSC2,RTB2,RTB2/A,RX,RX/A,RXQ4,RXQ4/A,SDB1,SE,SE/A,SH,SHE,SHEZ,SJC,SJP,SK,SMX2,SMX2/A,SNR,SNR/A,STP,STP/A,STQ,STQ/A,SW,SWE,SX,SX/A,SXB,SXE,SXEB,SXE4,SXE4/A,SXQ4,SXQ4/A,SXU,SXU/A,VA,VAH1,VA2,VA2/A,VDG2,VDG2/A,VH,VH/A,VH12,VH12/A,VMX,VNG,VTA,VTA2,VTA2/A,VWC2,VWC2/A,VX,VX/A,VXB,VXB/A,VXB7,VXB7/A,VXE,VXE/A,VXEB,VXEB/A,VXQ4,VXQ4/A,VXQ7,VXQ7/A,VXU,VXU/A,VXU1,VXU1/A,WH,WKD6,WKD6/A,WKT2,WKT2/A,WKT4,WKT4/A
	98079-56841	PLUG, SPARK (BP6ES) (NGK)	1	(1)	(1)	-----	EN,ES,ES1/A,ES2,ET,ETS,ETX,HTX,LD,LDB1,LDB3,LJ,LJ/A,LJG,LJG/A,LJG1,LJS,LJS/A,LK,LM9,LNJ,LNZ,LSS5,LSS5/A,LT,LT/A,QD,QD/A,QDA,RD,RD/A,RJ,RJ/A,RSS1,RSS1/A,SD,SD/A,SDB1,SDB3,SDB3/A,SHW,SHW/A,SJ,SJ/A,SJC,SJC1,SJC1/A,SJC5,SJC5/A,SJG,SJG/A,SJP,SK,SMS,SMS/A,WJ,WJ/A,WMK
			1	-	-	3543504	----- ES1
			1	-	-	3860624	----- LHZ,LSX,QHZ,SNR
			-	(1)	-	-----	

Ref. No.	Part No.	Description	Reqd. QTY			Serial No.	Parts catalogue code
			(1)	(2)	(3)		
19)	98079-56854	PLUG, SPARK (W20EP-U) (DENSO)	1	-	-	-----	ES1,ES1/A,ES2,LJ,LJ/A,LJG,LJG/A,LJS,LJS/A,LSS5,LSS5/A,LT,LT/A,QD QD/A,QT,QT/A,RD,RD/A,RJ,RJ/A,RSS1,RSS1/A,SD,SD/A,SDB3,SDB3/A,SHW SHW/A,SJ,SJ/A,SJC1,SJC1/A,SJC5,SJC5/A,SJG,SJG/A,SMS,SMS/A,WJ,WJ/A WMK
	98079-56855	PLUG, SPARK (W20EPR-U) (DENSO)	1	-	-	-----	EDT3,ED3,ED4,ED4/A,ED5,ED5/A,EN,ES,ET,ETS,ETX,HA,HAQ,HA2,HA2/A,HH HHQ4,HHQ4/A,HTX,HX,HX/A,HXQ4,HXQ4/A,LD,LDB1,LDB3,LH,LH/A,LHE,LHE4 LHE4/A,LHZ,LJG1,LK,LKS,LKS/A,LM9,LNJ,LNZ,LP,LP/A,LSS4,LSX,LSX/A LW,LX,LX/A,LXF,LXQ4,LXQ4/A,LXZ,LX2,LX2/A,PA,PAE,PA2,PA2/A,PMT2 PMT2/A,PX,PX/A,QA,QAB2,QAB2/A,QAE,QAE2,QAE2/A,QAG,QAG/A,QAG2 QAG2/A,QAQ,QAQ4,QAR2,QAR2/A,QA2,QA2/A,QC12,QC12/A,QDA,QE,QA,QH QH/A,QHB2,QHC,QHE,QHP1,QHP1/A,QHQ4,QHQ4/A,QHZ,QKA2,QMH,QMH/A,QMX2 QP,QP/A,QTC2,QTC2/A,QW24,QX,QX/A,QXB,QXB7,QXB7/A,QXC,QXC/A,QXC9 QXC9/A,QXE,QXE/A,QXEB,QXE4,QXE4/A,QXQ4,QXQ4/A,QXU,QXU/A,RA,RA2 RA2/A,RH,RHE,RHE4,RHQ4,RHQ4/A,RSC2,RTB2,RTB2/A,RX,RX/A,RXQ4 RXQ4/A,SDB1,SE,SE/A,SH,SHE,SHEZ,SJC,SJP,SK,SMX2,SMX2/A,SNR,SNR/A STP,STP/A,STQ,STQ/A,SW,SWE,SX,SX/A,AXB,SXE,SXEB,SXE4,SXQ4 SXQ4/A,SXU,SXU/A,VA,VAH1,VA2,VA2/A,VDG2,VDG2/A,VH,VH/A,VH12 VH12/A,VMX,VS4,VTA,VTA2,VTA2/A,VWC2,VWC2/A,VX,VX/A,VXB,VXB/A,VXB7 VXB7/A,VXE,VXE/A,VXEB,VXEB/A,VXQ4,VXQ4/A,VXQ7,VXQ7/A,VXU,VXU/A VXU1,VXU1/A,WH,WKD6,WKD6/A,WKT2,WKT2/A,WKT4,WKT4/A
	98079-55846	PLUG, SPARK (BPR5ES) (NGK) ...	1	-	-	-----	ES2
			1	(1)	1	-----	EDN,EDN2,EDN2/A,EDS,EDS1,EDS1/A,EDS2,EDS2/A,EDS3,EDS5,EDS6,EDS6/A EDT1,EDT1/A,EDT2,EDT3,EDT6,EDT6/A,ED2,ED2/A,EN2,EN2/A,ES3,ES3/A VSB1/A,VS3,VS4,VTE2
			1	-	-	3860625	VSB1
			(1)	-	-	-----	ED3,ED4,ED4/A,ED5,ED5/A,ES1,ES1/A,ES2,HA,HAQ,HA2,HA2/A,HH,HHQ4 HHQ4/A,HTX,HX,HX/A,HXQ4,HXQ4/A,LH,LH/A,LHE,LHE4,LHE4/A,LHZ,LKS LKS/A,LP,LP/A,LSS4,LSX/A,LW,LX,LX/A,LXF,LXQ4,LXQ4/A,LXZ,LX2,LX2/A PA,PAE,PA2,PA2/A,PMT2,PMT2/A,PX,PX/A,QA,QAB2,QAB2/A,QAE,QAE2 QAE2/A,QAG,QAQ/A,QAG2,QAG2/A,QAQ,QAQ4,QAR2,QAR2/A,QA2,QA2/A,QC12 QC12/A,QE,QA,QH,QH/A,QHB2,QHC,QHE,QHP1,QHP1/A,QHQ4,QHQ4/A,QHZ QKA2,QMH,QMH/A,QMX2,QP,QP/A,QTC2,QTC2/A,QW24,QX,QX/A,QXB,QXB7 QXB7/A,QXC,QXC/A,QXC9,QXC9/A,QXE,QXE/A,QXEB,QXE4,QXE4/A,QXQ4 QXQ4/A,QXU,QXU/A,RA,RA2,RA2/A,RH,RHE,RHE4,RHQ4,RHQ4/A,RSC2,RTB2 RTB2/A,RX,RX/A,RXQ4,RXQ4/A,SE,SE/A,SH,SHE,SHEZ,SJP,SMX2,SMX2/A SNR/A,STP,STP/A,STQ,STQ/A,SW,SWE,SX,SX/A,AXB,SXE,SXEB,SXE4,SXE4/A SXQ4,SXQ4/A,SXU,SXU/A,VA,VAH1,VA2,VA2/A,VDG2,VDG2/A,VH,VH/A,VH12 VH12/A,VMT2,VMX,VNG,VTA,VTA2,VTA2/A,VWC2,VWC2/A,VX,VX/A,VXB,VXB/A VXB7,VXB7/A,VXE,VXE/A,VXEB,VXEB/A,VXQ4,VXQ4/A,VXQ7,VXQ7/A,VXU VXU/A,VXU1,VXU1/A,WH,WKD6,WKD6/A,WKT2,WKT2/A,WKT4,WKT4/A
			(1)	-	-	3860625	LSX,SNR
			-	(1)	(1)	-----	



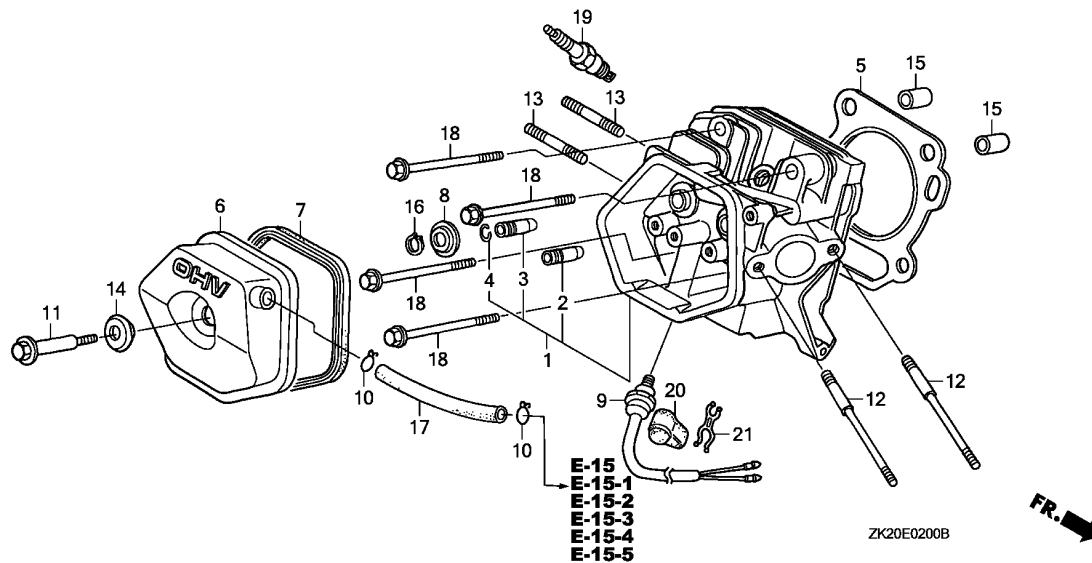

Ref. No.	Part No.	Description	Reqd. QTY			Serial No.	Parts catalogue code
			(1)	(2)	(3)		
19)	98079-56846	PLUG, SPARK (BPR6ES)(NGK) ...	1	-	-	-----	ED3,ED4,ED4/A,ED5,ED5/A,HA,HAQ,HA2,HA2/A,HH,HHQ4,HHQ4/A,HX,HX/A,HXQ4,HXQ4/A,LH,LH/A,LHE,LHE4,LHE4/A,LKS,LKS/A,LP,LP/A,LSS4,LSX/A,LW,LX,LX/A,LXF,LXQ4,LXQ4/A,LXZ,LX2,LX2/A,PA,PAE,PA2,PA2/A,PMT2,PMT2/A,PX,PX/A,QA,QAB2,QAB2/A,QAE,QAE2,QAE2/A,QAG,QAG/A,QAG2,QAG2/A,QAQ,QAQ4,QAR2,QAR2/A,QA2,QA2/A,QC12,QC12/A,QE,QE/A,QH,QH/A,QHB2,QHC,QHE,QHP1,QHP1/A,QHQ4,QHQ4/A,QKA2,QMH,QMH/A,QMX2,QP,QP/A,QTC2,QTC2/A,QW24,QX,QX/A,QXB,QXB7,QXB7/A,QXC,QXC/A,QXC9,QXC9/A,QXE,QXE/A,QXEB,QXE4,QXE4/A,QXQ4,QXQ4/A,QXU,QXU/A,RA,RA2,RA2/A,RH,RHE,RHE4,RHQ4,RHQ4/A,RSC2,RTB2,RTB2/A,RX,RX/A,RXQ4,RXQ4/A,SE,SE/A,SH,SHE,SHEZ,SMX2,SMX2/A,SNC1,SNE1,SNR/A,STP,STP/A,STQ,STQ/A,SW,SWE,SX,SX/A,SXB,SXE,SXEB,SXE4,SXE4/A,SXQ4,SXQ4/A,SXU,SXU/A,VA,VAH1,VA2,VA2/A,VDG2,VDG2/A,VH,VH/A,VH12,VH12/A,VMX,VNG,VTA,VTA2,VTA2/A,VWC2,VWC2/A,VX,VX/A,VXB,VXB/A,VXB7,VXB7/A,VXE,VXE/A,VXEB,VXEB/A,VXQ4,VXQ4/A,VXQ7,VXQ7/A,VXU,VXU/A,VXU1,VXU1/A,WH,WKD6,WKD6/A,WKT2,WKT2/A,WKT4,WKT4/A
			1	-	-	3860625	-----
			1	-	-	3543503	ES1
			-	(1)	1	-----	3300511
20	16505-ZE2-700	CAP, THERMO SWITCH	1	-	-	-----	EDS3
21	90658-SAO-003	CLIP, WIRE HARNESS	1	-	-	-----	EDS3

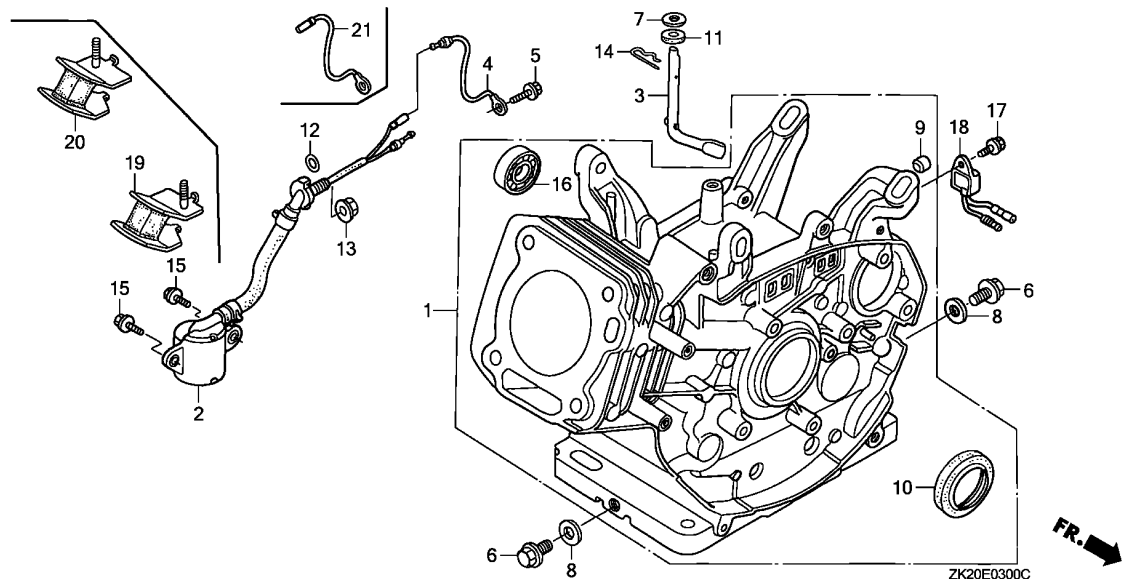

Ref. No.	L.O.N.	(Relative ref. Number) Description	F.R.T.
1	1101A0	BARREL, CYLINDER	1.8
2		(12)	
	6151E8	SWITCH, OIL LEVEL	0.5
3	1161B4	SHAFT, GOVERNOR ARM	1.1
4		(21)	
	6111E5	SUB HARNESS, OIL LEVEL SWITCH	0.1
10	1101E4	OIL SEAL, CRANKSHAFT :FRONT ..	1.8
16	1101F4	BEARING, BALANCER WEIGHT :FRONT	1.9
18	6151A0	ALERT UNIT, ENGINE OIL	0.1

Ref. No.	Part No.	Description	Reqd. QTY			Serial No.	Parts catalogue code
			(1)	(2)	(3)		
1	12000-ZE2-040	BARREL ASSY., CYLINDER (STD.)	1	(1)	-	-----	EN,ES,ET,HH,HTX,LD,LDB1,LDB3,LHZ,LJG1,LM9,LSS4,LW,L1,P1,QDA,QHC QHZ,Q1,RH,R1,SDB1,SH,SJC,SW,S1,VTE2,V1,WH,W1
			1	-	-	4081304	ED4,HHQ4,LH,LJ,LJG,LP,LT,QD,QE,QH,QHP1,QHQ4,QMH,QP,QT,RD,RHQ4,RJ SD,SDB3,SE,SJ,SJG,STP,STQ,VH,WJ
	12000-ZE2-815	BARREL ASSY., CYLINDER (ALERT)	1	-	1	-----	EDN,EDN2,EDT1,EDT2,EDT6,ED2,ED5,EN2,ES1,ES3,ETX,HX,HXQ4,LSX,LX LXQ4,LXZ,LX2,PMT2,PX,QAG,QMX2,QTC2,QX,QXB,QXB7,QXC,QXC9,QXQ4,QXU RX,RXQ4,SJC1,SJC5,SJP,SMS,SMX2,SNC1,SNR,SX,SXB,SXQ4,SXU,VDG2,VMX VNG,VSU1,VX,VXB,VXB7,VXP,VXQP,VXQ4,VXQ7,VXU,VXU1,WKD6,WKT2,WKT4
	12000-ZE2-824	BARREL ASSY., CYLINDER (SELFSTARTER+ALERT)	-	(1)	-	-----	EDS,EDS3,EDS5,ETS,L1,P1,QXEB,Q1,R1,SNE1,SXE,SXEB,S1,V1,W1
	12000-ZE2-834	BARREL ASSY., CYLINDER (BALANCER+ALERT)	1	-	-	4081304	EDS1,EDS2,QXE,QXE4,SXE4,VXE,VXEB
	12000-ZE2-844	BARREL ASSY., CYLINDER (BALANCER+SELFSTARTER+ALERT)	1	-	-	4081304	HA,HAQ,PA,QA,QAQ,QAQ4,QKA2,RA,RSC2,VA,VAH1,VTA HA2,PA2,QAB2,QAG2,QA2,RA2,RTB2,VA2,VH12,VTA2,VWC2
	12000-ZE2-854	BARREL ASSY., CYLINDER (BALANCER)	1	-	-	4081304	PAE,QAE QAE2,QAR2
	12000-ZE2-864	BARREL ASSY., CYLINDER (SELF-STARTER)	1	-	-	4081304	LK,SK QC12
	12000-ZE2-874	BARREL ASSY., CYLINDER (BALANCER+SELFSTARTER)	1	-	-	4081304	ED3,LHE,LNJ,QHE,RHE,RHE4,SHE,SHEZ,SWE,WKA LHE4,LNZ,LSS5,RSS1
	12000-ZE2-050	BARREL ASSY., CYLINDER (STD.)	1	-	-	4081305	LKS ED4,HHQ4,LH,LJ,LJG,LP,LT,QD,QE,QH,QHP1,QHQ4,QMH,QP,QT,RD,RHQ4,RJ SD,SDB3,SE,SJ,SJG,STP,STQ,VH,WJ



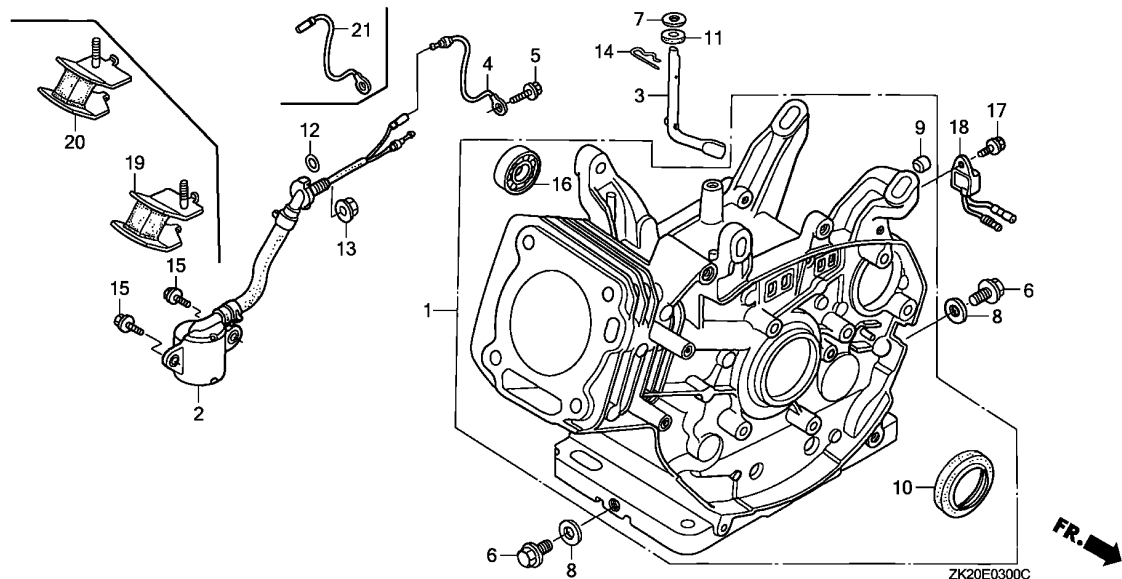

Ref. No.	Part No.	Description	Reqd. QTY			Serial No.	Parts catalogue code
			(1)	(2)	(3)		
(1)	12000-ZE2-825	BARREL ASSY., CYLINDER (SELFSTARTER+ALERT)	1	(1)	-	-----	EDS6,L1/A,Q1/A,R1/A,S1/A,W1/A
	12000-ZE2-835	BARREL ASSY., CYLINDER (BALANCER+ALERT)	1	-	-	4081305	----- EDS1,EDS2,QXE,QXE4,SXE4,VXE,VXEB
	12000-ZE2-845	BARREL ASSY., CYLINDER (BALANCER+SELFSTARTER+ALERT)	1	-	-	4081305	----- HA2,PA2,QAB2,QAG2,QA2,RA2,RTB2,VA2,VH12,VTA2,VWC2
	12000-ZE2-855	BARREL ASSY., CYLINDER (BALANCER)	1	-	-	4081305	----- QAE2,QAR2
	12000-ZE2-865	BARREL ASSY., CYLINDER (SELF-STARTER)	1	(1)	-	-----	LJS
	12000-ZE2-875	BARREL ASSY., CYLINDER (BALANCER+SELFSTARTER)	1	-	-	4081305	----- QC12
	12000-ZE2-060	BARREL ASSY., CYLINDER (STD.)	-	(1)	-	-----	L1,P1,Q1,R1,SHW,S1,V1,W1
	12000-ZE2-407	BARREL ASSY., CYLINDER (SELFSTARTER+ALERT)	1	-	-	-----	LHE4,LNZ,LSS5,RSS1
	12000-ZE2-408	BARREL ASSY., CYLINDER (BALANCER+ALERT)	1	-	-	-----	L1/A,Q1/A,R1/A,S1/A,W1/A
	12000-ZE2-409	BARREL ASSY., CYLINDER (BALANCER+SELFSTARTER+ALERT)	1	-	-	-----	EDS1/A,EDS2/A,EDS6/A,QXE/A,QXE4/A,SXE4/A,VXE/A,VXEB/A
	12000-ZE2-866	BARREL ASSY., CYLINDER (SELF-STARTER)	-	(1)	-	-----	HA2/A,PA2/A,QAB2/A,QAG2/A,QA2/A,QW24,RA2/A,RTB2/A,VA2/A,VH12/A,VMT2,VTA2/A,VWC2/A
	12000-ZE2-Q00	BARREL ASSY., CYLINDER (BALANCER)	1	-	-	-----	QAE2/A,QAR2/A
	12000-ZE2-Q10	BARREL ASSY., CYLINDER (SELF-STARTER)	1	-	-	-----	L1/A,Q1/A,R1/A,S1/A,W1/A
			1	-	-	-----	LJS/A,QC12/A
			1	-	-	-----	LHE4/A,LSS5/A,RSS1/A,SHW/A

Ref. No.	Part No.	Description	Reqd. QTY			Serial No.	Parts catalogue code
			(1)	(2)	(3)		
(1)	12000-ZE2-406	BARREL ASSY., CYLINDER (ALERT)	1	-	1		EDN2/A,EDT1/A,EDT3,EDT6/A,ED2/A,ED5/A,EN2/A,ES1/A,ES2,ES3/A,HX/A,HAQ4/A,LSX/A,LX/A,LXF,LXQ4/A,LX2/A,PMT2/A,PX/A,QAG/A,QTC2/A,QX/A,QXB7/A,QXC/A,QXC9/A,QXQ4/A,QXU/A,RX/A,RXQ4/A,SJC1/A,SJC5/A,SMS/A,SMX2/A,SNR/A,SX/A,SXQ4/A,SXU/A,VDG2/A,VS1/A,VS3,VS4,VX/A,VXB/A,VXB7/A,VXP/A,VXQ4/A,VXQ7/A,VXU/A,VXU1/A,WKD6/A,WKT2/A,WKT4/A
	12000-ZE2-876	BARREL ASSY., CYLINDER (BALANCER+SELFSTARTER)	1	-	-		LKS/A
	12000-ZE2-405	BARREL ASSY., CYLINDER (STD.)	1	-	-		ED4/A,HHQ4/A,LH/A,LJ/A,LJG/A,LP/A,LT/A,QD/A,QE/A,QH/A,QHB2,QHP1/A,QHQ4/A,QMH/A,QP/A,QT/A,RD/A,RHQ4/A,RJ/A,SD/A,SDB3/A,SE/A,SJ/A,SJG/A,STP/A,STQ/A,VH/A,WJ/A,WJK
2	15510-ZE2-043	SWITCH ASSY., OIL LEVEL	1	(1)	-		EDN,EDN2,EDN2/A,EDS,EDS1,EDS2,EDS2/A,EDS3,EDS5,EDS6,EDS6/A,EDT1,EDT2,EDT6,EDT6/A,ED2,ED2/A,ED5,ED5/A,EN2,EN2/A,ES1,ES3,ETS,ETX,HA,HAQ,HA2,HA2/A,HX,HXQ4,HAQ4/A,LSX,LX,LXQ4,LXQ4/A,LXZ,LX2,LX2/A,L1,L1/A,PA,PAE,PA2,PA2/A,PMT2,PMT2/A,PX,P1,QA,QAB2,QAB2/A,QAE,QAE2,QAE2/A,QAG,QAG/A,QAG2,QAG2/A,QAQ,QAQ4,QAR2,QAR2/A,QA2,QA2/A,QKA2,QMX2,QTC2,QTC2/A,QW24,QX,QXB,QXB7,QXB7/A,QXC,QXC9,QXC9/A,QXE,QXEB,QXE4,QXE4/A,QXQ4,QXQ4/A,QXU,QXU/A,Q1,RA,RA2,RA2/A,RSC2,RTB2,RTB2/A,RX,RXQ4,RXQ4/A,R1,R1/A,SJC1,SJC5,SJP,SMS,SMX2,SMX2/A,SNC1,SNE1,SNR,SX,SXB,SXE,SXEB,SXE4,SXE4/A,SXQ4,SXQ4/A,SXU,SXU/A,S1,VA,VAH1,VA2,VA2/A,VDG2,VDG2/A,VH12,VH12/A,VMT2,VMX,VNG,VS1,VS1/A,VTA,VTA2,VTA2/A,VWC2,VWC2/A,VX,VXB,VXB/A,VXB7,VXB7/A,VXE,VXEB,VXEB/A,VXQ4,VXQ4/A,VXQ7,VXQ7/A,VXU,VXU/A,VXU1,VXU1/A,V1,WKD6,WKD6/A,WKT2,WKT2/A,WKT4,WKT4/A,W1
			1	(1)	-	4850561	EDS1/A,EDT1/A,ES1/A,ES3/A,HX/A,LSX/A,LX/A,LXF,PX/A,QX/A,QXC/A,QXE/A,Q1/A,RX/A,SJC1/A,SJC5/A,SMS/A,SNR/A,SX/A,S1/A,VS3,VX/A,VXE/A,W1/A
	15510-ZE2-053	1	(1)	-	4850562	EDS1/A,EDT1/A,ES1/A,ES3/A,HX/A,LSX/A,LX/A,LXF,PX/A,QX/A,QXC/A,QXE/A,Q1/A,RX/A,SJC1/A,SJC5/A,SMS/A,SNR/A,SX/A,S1/A,VS3,VX/A,VXE/A,W1/A
			1	-	-		EDT3,ES2,VS4
3	16541-ZE2-010	SHAFT, GOVERNOR ARM	1	1	1		
4	32197-ZE2-003	SUB HARNESS	1	(1)	-	3116815	3566259 ED2,ES1,ETX,HA,HX,LX,LXZ,L1,PA,PX,P1,QA,QAE,QX,QXB,QXC,QXE,QXEB,Q1,RA,RX,R1,SJP,SNR,SX,SXB,SXE,SXEB,S1,VA,VAH1,VNG,VX,VXB,VXE,VXEB,V1,W1
			1	-	-		3566259 EDS,EDS1,EDS3,EDS5,EDT1,ED5,HAQ,HA2,HAQ4,LSX,LXQ4,LX2,PAE,PA2,PMT2,QAE2,QAG2,QAQ,QAQ4,QAR2,QA2,QKA2,QXC9,QXE4,QXQ4,RA2,RSC2,RTB2,RXQ4,SJC1,SJC5,SMS,SMX2,SNC1,SNE1,SXE4,SXQ4,VA2,VH12,VTA,VWC2,VXQ4,VXU,WKT2
			-	-	1	1000005	VXP,VXQP
5	90013-883-000	BOLT, FLANGE, 6X12(CT200) ...	1	(1)	-	3116815	3566259 ED2,ES1,ETX,HA,HX,LX,LXZ,L1,PA,PX,P1,QA,QAE,QX,QXB,QXC,QXE,QXEB,Q1,RA,RX,R1,SJP,SNR,SX,SXB,SXE,SXEB,S1,VA,VAH1,VNG,VX,VXB,VXE,VXEB,V1,W1
			1	-	-		VS1
			1	-	-	3566260	EDN,EDN2,ES3,ETS
			1	-	-	3566259	EDS,EDS1,EDS3,EDS5,EDT1,ED5,HAQ,HA2,HAQ4,LSX,LXQ4,LX2,PAE,PA2,PMT2,QAE2,QAG2,QAQ,QAQ4,QAR2,QA2,QKA2,QXC9,QXE4,QXQ4,RA2,RSC2,RTB2,RXQ4,SJC1,SJC5,SMS,SMX2,SNC1,SNE1,SXE4,SXQ4,VA2,VH12,VTA,VWC2,VXQ4,VXU,WKT2
			-	-	1	1000005	VXP,VXQP
6	90131-883-000	BOLT, DRAIN PLUG, 12X15	2	2	2		
7	90446-KE1-000	WASHER, 8.2X17X0.8	1	1	1		
8	94109-12000	WASHER, DRAIN PLUG, 12MM	2	2	2		



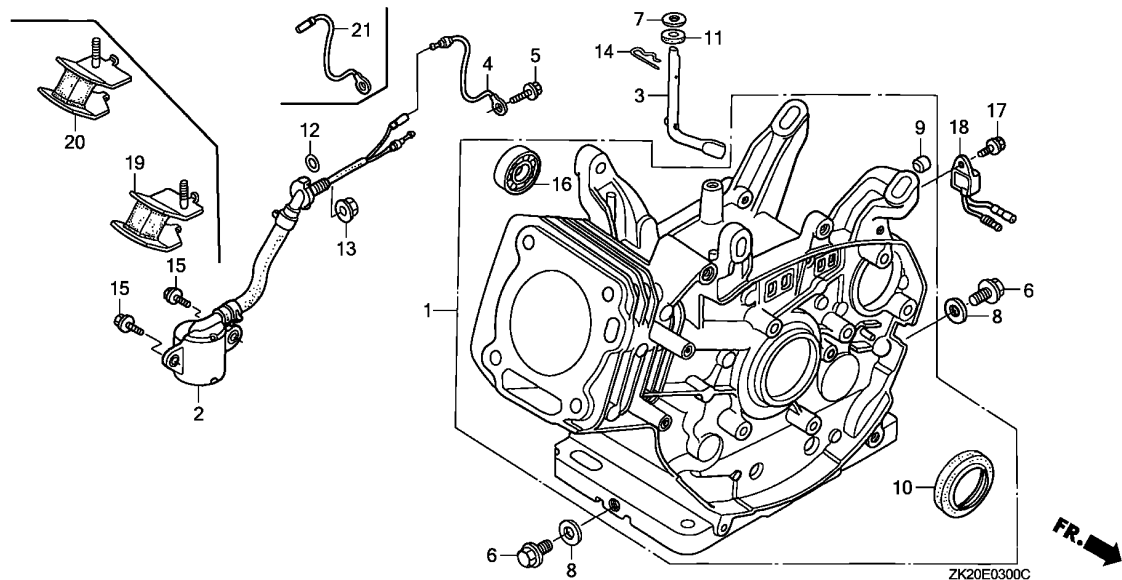

2

Ref. No.	Part No.	Description	Reqd. QTY			Serial No.	Parts catalogue code
			(1)	(2)	(3)		
9	90801-ZE2-003	PLUG, SEALING (RUBBER 10MM)	1	(1)	-	-----	ED3,ED4,EN,ES,ET,HH,HHQ4,HTX,LD,LDB1,LDB3,LH,LHE,LHE4,LHZ,LJ,LJG,LJG1,LJS,LK,LKS,LKS/A,LM9,LNJ,LNZ,LP,LSS4,LSS5,LSS5/A,LT,LW,L1,P1,QD,QDA,QE,QH,QHC,QHE,QHP1,QHQ4,QHZ,QMH,QP,QT,Q1,RD,RH,RHE,RHE4,RHQ4,RJ,RSS1,RSS1/A,R1,SD,SDB1,SDB3,SE,SH,SHE,SHEZ,SHW,SHW/A,SJ,SJC,SJG,SJP,SK,STP,STQ,SW,SWE,S1,VH,VTE2,V1,WH,WJ,WKA,W1
			1	(1)	-	4785709	ED4/A,HHQ4/A,LH/A,LHE4/A,LJ/A,LJG/A,LJS/A,LP/A,LT/A,L1/A,QC12/A,QD/A,QE/A,QH/A,QHB2,QHP1/A,QHQ4/A,QMH/A,QP/A,QT/A,Q1/A,RD/A,RHQ4/A,RJ/A,R1/A,SD/A,SDB3/A,SE/A,SJ/A,SJG/A,STP/A,STQ/A,S1/A,VH/A,WJ/A,W1/A

Ref. No.	Part No.	Description	Reqd. QTY			Serial No.	Parts catalogue code
			(1)	(2)	(3)		
10	91201-890-003	OIL SEAL, 30X46X8	1	-	-	-----	EDN,EDN2,EDN2/A,EDS,EDS1,EDS1/A,EDS2,EDS2/A,EDS3,EDS5,EDS6,EDS6/A,EDT1,EDT1/A,EDT2,EDT3,EDT6,EDT6/A,ED2,ED2/A,ED3,ED4,ED4/A,ED5,ED5/A,EN,EN2,EN2/A,ES,ES1,ES1/A,ES2,ES3,ES3/A,ET,ETS,ETX,HA,HAQ,HA2,HA2/A,HH,HHQ4,HHQ4/A,HTX,HX,HX/A,HXQ4,HXQ4/A,LD,LDB1,LDB3,LH,LH/A,LHE,LHE4,LHE4/A,LHZ,LJ,LJ/A,LJG,LJG/A,LJG1,LJS,LJS/A,LK,LKS,LKS/A,LM9,LNJ,LNZ,LP,LP/A,LSS4,LSS5,LSS5/A,LSX,LSX/A,LT,LT/A,LW,LX,LX/A,LXF,LXQ4,LXQ4/A,LXZ,LX2,LX2/A,PA,PAE,PA2,PA2/A,PMT2,PMT2/A,PX,PX/A,QA,QAB2,QAB2/A,QAE,QAE2,QAE2/A,QAG,QAG/A,QAG2,QAG2/A,QAQ,QAQ4,QAR2,QAR2/A,QA2,QA2/A,QC12,QC12/A,QD,QD/A,QDA,QE/A,QH,QH/A,QHB2,QHC,QHE,QHP1,QHP1/A,QHQ4,QHQ4/A,QHZ,QKA2,QMH,QMH/A,QMX2,QP,QP/A,QT,QT/A,QTC2,QTC2/A,QW24,QX,QX/A,QXB,QXB7,QXB7/A,QXC,QXC/A,QXC9,QXC9/A,QXE,QXE/A,QXEB,QXE4,QXE4/A,QXQ4,QXQ4/A,QXU,QXU/A,RA,RA2,RA2/A,RD,RD/A,RH,RHE,RHE4,RHQ4,RHQ4/A,RJ,RJ/A,RSC2,RSS1,RSS1/A,RTB2,RTB2/A,RX,RX/A,RXQ4,RXQ4/A,SD,SD/A,SDB1,SDB3,SDB3/A,SE,SE/A,SH,SHE,SHEZ,SHW,SHW/A,SJ,SJ/A,SJC,SJC1,SJC1/A,SJC5,SJC5/A,SJG,SJG/A,SJP,SK,SMS,SMS/A,SMX2,SMX2/A,SNC1,SNE1,SNR,SNR/A,STP,STP/A,STQ,STQ/A,SW,SWE,SX,SX/A,SXB,SXE,SXEB,SXE4,SXE4/A,SXQ4,SXQ4/A,SXU,SXU/A,VA,VAH1,VA2,VA2/A,VDG2,VDG2/A,VH,VH/A,VH12,VH12/A,VMT2,VMX,VNG,VSB1/A,VS3,VS4,VTA,VTA2,VTA2/A,VTE2,VWC2,VWC2/A,VX,VX/A,VXB,VXB/A,VXB7,VXB7/A,VXE,VXE/A,VXEB,VXEB/A,VXQ4,VXQ4/A,VXQ7,VXQ7/A,VXU,VXU/A,VXU1,VXU1/A,WH,WJ,WJ/A,WKA,WKD6,WKD6/A,WKT2,WKT2/A,WKT4,WKT4/A,WMK
			1	-	-	3634565 -----	VSB1
			-	(1)	1		
11	91203-952-771	OIL SEAL, 8X14X5	1	1	-	-----	LJ,LK,LNJ,L1,Q1,RJ,R1,SJ,SJP,SK,STP,STQ,S1,WJ,WKA,W1
12	91353-671-004	O-RING, 14MM(NOK)	1	-	-	-----	EDN,EDN2,EDN2/A,EDS,EDS1,EDS1/A,EDS2,EDS2/A,EDS3,EDS5,EDS6,EDS6/A,EDT1,EDT1/A,EDT2,EDT3,EDT6,EDT6/A,ED2,ED2/A,ED3,ED4,EN2,EN2/A,ES1,ES1/A,ES2,ES3,ES3/A,ETS,ETX,HA,HAQ,HA2,HA2/A,HX,HX/A,HXQ4,HXQ4/A,LSX,LSX/A,LX,LX/A,LXF,LXQ4,LXQ4/A,LXZ,LX2,LX2/A,PA,PAE,PA2,PA2/A,PMT2,PMT2/A,PX,PX/A,QA,QAB2,QAB2/A,QAE,QAE2,QAE2/A,QAG,QAG/A,QAG2,QAG2/A,QAQ,QAQ4,QAR2,QAR2/A,QA2,QA2/A,QKA2,QMX2,QTC2,QTC2/A,QW24,QX,QX/A,QXB,QXB7,QXB7/A,QXC,QXC/A,QXC9,QXC9/A,QXE,QXE/A,QXEB,QXE4,QXE4/A,QXQ4,QXQ4/A,QXU,QXU/A,RA,RA2,RA2/A,RSC2,RTB2,RTB2/A,RX,RX/A,RXQ4,RXQ4/A,SJC1,SJC1/A,SJC5,SJC5/A,SJP,SMS,SMS/A,SMX2,SMX2/A,SNC1,SNE1,SNR,SNR/A,SX,SX/A,SXB,SXE,SXEB,SXE4,SXE4/A,SXQ4,SXQ4/A,SXU,SXU/A,VA,VAH1,VA2,VA2/A,VDG2,VDG2/A,VH12,VH12/A,VMT2,VMX,VNG,VSB1,VSB1/A,VS3,VS4,VTA,VTA2,VTA2/A,VWC2,VWC2/A,VX,VX/A,VXB,VXB/A,VXB7,VXB7/A,VXE,VXE/A,VXEB,VXEB/A,VXQ4,VXQ4/A,VXQ7,VXQ7/A,VXU,VXU/A,VXU1,VXU1/A,WKD6,WKD6/A,WKT2,WKT2/A,WKT4,WKT4/A
			-	(1)	1		
13	94050-10000	NUT, FLANGE, 10MM	1	-	-	-----	EDN,EDN2,EDN2/A,EDS,EDS1,EDS1/A,EDS2,EDS2/A,EDS3,EDS5,EDS6,EDS6/A,EDT1,EDT1/A,EDT2,EDT3,EDT6,EDT6/A,ED2,ED2/A,ED3,ED5,ED5/A,EN2,EN2/A,ES1,ES1/A,ES2,ES3,ES3/A,ETS,ETX,HA,HAQ,HA2,HA2/A,HX,HX/A,HXQ4,HXQ4/A,LSX,LSX/A,LX,LX/A,LXF,LXQ4,LXQ4/A,LXZ,LX2,LX2/A,PA,PAE,PA2,PA2/A,PMT2,PMT2/A,PX,PX/A,QA,QAB2,QAB2/A,QAE,QAE2,QAE2/A,QAG,QAG/A,QAG2,QAG2/A,QAQ,QAQ4,QAR2,QAR2/A,QA2,QA2/A,QKA2,QMX2,QTC2,QTC2/A,QW24,QX,QX/A,QXB,QXB7,QXB7/A,QXC,QXC/A,QXC9,QXC9/A,QXE,QXE/A,QXEB,QXE4,QXE4/A,QXQ4,QXQ4/A,QXU,QXU/A,RA,RA2,RA2/A,RSC2,RTB2,RTB2/A,RX,RX/A,RXQ4,RXQ4/A,SJC1,SJC1/A,SJC5,SJC5/A,SJP,SMS,SMS/A,SMX2,SMX2/A,SNC1,SNE1,SNR,SNR/A,SX,SX/A,SXB,SXE,SXEB,SXE4,SXE4/A,SXQ4,SXQ4/A,SXU,SXU/A,VA,VAH1,VA2,VA2/A,VDG2,VDG2/A,VH12,VH12/A,VMT2,VMX,VNG,VSB1,VSB1/A,VS3,VS4,VTA,VTA2,VTA2/A,VWC2,VWC2/A,VX,VX/A,VXB,VXB/A,VXB7,VXB7/A,VXE,VXE/A,VXEB,VXEB/A,VXQ4,VXQ4/A,VXQ7,VXQ7/A,VXU,VXU/A,VXU1,VXU1/A,WKD6,WKD6/A,WKT2,WKT2/A,WKT4,WKT4/A
			-	(1)	1		



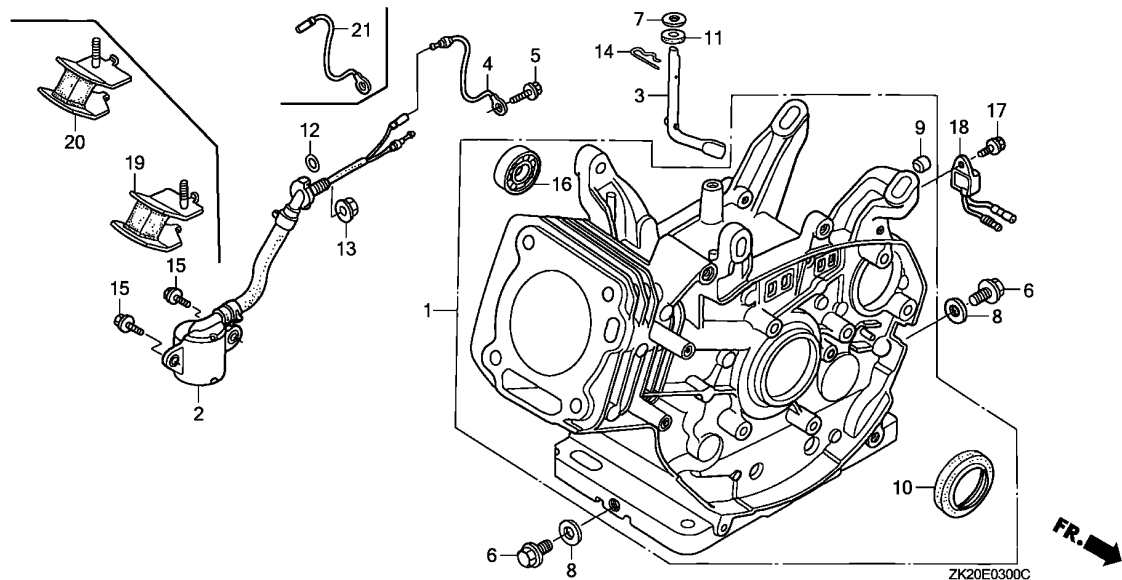

Ref. No.	Part No.	Description	Reqd. QTY			Serial No.	Parts catalogue code
			(1)	(2)	(3)		
14	94251-08000	PIN, LOCK, 8MM	1	1	-	3332421	EDN,EDS,EDS1,EDS3,EDS5,EDT1,ED2,ED3,ED4,ED5,EN,ES,ES1,ES3,ET,ETS ETX,HA,HAQ,HA2,HH,HHQ4,HTX,HX,HXQ4,LD,LH,LHE,LHE4,LJ,LJG,LK,LKS LM9,LNJ,LNZ,LP,LW,LX,LXQ4,LXZ,LX2,L1,PA,PAE,PA2,PX,P1,QA,QAE,QAE2 QAQ,QAQ4,QA2,QD,QDA,QE,QH,QHC,QHE,QHQ4,QP,QT,QX,QXB,QXC,QXE,QXEB QXE4,QXQ4,Q1,RA,RA2,RD,RH,RHE,RHE4,RHQ4,RJ,RX,RXQ4,R1,SD,SE,SH SHE,SHEZ,SJ,SJG,SJP,SK,SMS,SNC1,SNE1,SNR,STP,STQ,SW,SWE,SX, SXB SXE,SXEB,SXE4,SXQ4,S1,VA,VAH1,VA2,VH,VNG,VTA,VX,VXB,VXE,VXEB,VXQ4 VXU,V1,WH,WJ,WKA,W1

Ref. No.	Part No.	Description	Reqd. QTY			Serial No.	Parts catalogue code
			(1)	(2)	(3)		
14)	94251-10000	PIN, LOCK, 10MM	1	1	-		EDN2,EDN2/A,EDS1/A,EDS2,EDS2/A,EDS6,EDS6/A,EDT1/A,EDT2,EDT3,EDT6 EDT6/A,ED2/A,ED4/A,ED5/A,EN2,EN2/A,ES1/A,ES2,ES3/A,HA2/A,HHQ4/A HX/A,HXQ4/A,LDB1,LDB3,LH/A,LHE4/A,LHZ,LJ/A,LJG/A,LJG1,LJS,LJS/A LKS/A,LP/A,LSS4,LSS5,LSS5/A,LSX,LSX/A,LT,LT/A,LX/A,LXF,LXQ4/A LX2/A,L1/A,PA2/A,PMT2,PMT2/A,PX/A,QAB2,QAB2/A,QAE2/A,QAG,QAG/A QAG2,QAG2/A,QAR2,QAR2/A,QA2/A,QC12,QC12/A,QD/A,QA/A,QH/A,QHB2 QHP1,QHP1/A,QHQ4/A,QHZ,QKA2,QMH,QMH/A,QMX2,QP/A,QT/A,QTC2,QTC2/A QW24,QX/A,QXB7,QXB7/A,QXC/A,QXC9,QXC9/A,QXE/A,QXE4/A,QXQ4/A,QXU QXU/A,Q1/A,RA2/A,RA2/A,RD/A,RHQ4/A,RJ/A,RSC2,RSS1,RSS1/A,RTB2,RTB2/A RX/A,RXQ4/A,R1/A,SD/A,SDB1,SDB3,SDB3/A,SE/A,SHW,SHW/A,SJ/A,SJC SJC1,SJC1/A,SJC5,SJC5/A,SJG/A,SMS/A,SMX2,SMX2/A,SNR/A,STP/A,STQ/A SX/A,SXE4/A,SXQ4/A,SXU,SXU/A,S1/A,VA2/A,VDG2,VDG2/A,VH/A,VH12 VH12/A,VMT2,VMX,VSB1,VSB1/A,VS3,VS4,VTA2,VTA2/A,VTE2,VWC2,VWC2/A VX/A,VXB/A,VXB7,VXB7/A,VXE/A,VXEB/A,VXQ4/A,VXQ7,VXQ7/A,VXU/A,VXU1 VXU1/A,WJ/A,WKD6,WKD6/A,WKT2,WKT2/A,WKT4,WKT4/A,WMK,W1/A EDN,EDS,EDS1,EDS3,EDS5,EDT1,ED2,ED3,ED4,ED5,EN,ES,ES1,ES3,ET,ETS ETX,HA,HAQ,HA2,HH,HHQ4,HTX,HX,HXQ4,LD,LH,LHE,LHE4,LJ,LJG,LK,LKS LM9,LNJ,LNZ,LP,LW,LX,LXQ4,LXZ,LX2,L1,PA,PAE,PA2,PX,P1,QA,QAE,QAE2 QAQ,QAQ4,QA2,QD,QDA,QE,QH,QHC,QHE,QHQ4,QP,QT,QX,QXB,QXC,QXE,QXEB QXE4,QXQ4,Q1,RA,RA2,RD,RH,RHE,RHE4,RHQ4,RJ,RX,RXQ4,R1,SD,SE,SH SHE,SHEZ,SJ,SJG,SJP,SK,SMS,SNC1,SNE1,SNR,STP,STQ,SW,SWE,SX, SXB SXE,SXEB,SXE4,SXQ4,S1,VA,VAH1,VA2,VH,VNG,VTA,VX,VXB,VXE,VXEB,VXQ4 VXU,V1,WH,WJ,WKA,W1
15	95701-06012-00	BOLT, FLANGE, 6X12	2	-	-	3332422	EDN,EDN2,EDN2/A,EDS,EDS1,EDS1/A,EDS2,EDS2/A,EDS3,EDS5,EDS6,EDS6/A EDT1,EDT1/A,EDT2,EDT3,EDT6,EDT6/A,ED2,ED2/A,ED5,ED5/A,EN2,EN2/A ES1,ES1/A,ES2,ES3,ES3/A,ETS,ETX,HA,HAQ,HA2,HA2/A,HX,HX/A,HXQ4/A HXQ4/A,LSX,LSX/A,LX,LX/A,LXF,LXQ4,LXQ4/A,LXZ,LX2,LX2/A,PA,PAE,PA2 PA2/A,PMT2,PMT2/A,PX,PX/A,QA,QAB2,QAB2/A,QAE,QAE2,QAE2/A,QAG QAG/A,QAG2,QAG2/A,QAQ,QAQ4,QAR2,QAR2/A,QA2,QA2/A,QKA2,QMX2,QTC2 QTC2/A,QW24,QX,QX/A,QXB,QXB7,QXB7/A,QXC,QXC/A,QXC9,QXC9/A,QXE QXE/A,QXEB,QXE4,QXE4/A,QXQ4,QXQ4/A,QXU,QXU/A,RA,RA2,RA2/A,RSC2 RTB2,RTB2/A,RX,RX/A,RXQ4,RXQ4/A,SJC1,SJC1/A,SJC5,SJC5/A,SJP,SMS SMS/A,SMX2,SMX2/A,SNC1,SNE1,SNR,SNR/A,SX,SX/A,SXB,SXE,SXEB,SXE4 SXE4/A,SXQ4,SXQ4/A,SXU,SXU/A,VA,VAH1,VA2,VA2/A,VDG2,VDG2/A,VH12 VH12/A,VMT2,VMX,VNG,VSB1,VSB1/A,VS3,VS4,VTA,VTA2,VTA2/A,VWC2 VWC2/A,VX,VX/A,VXB,VXB/A,VXB7,VXB7/A,VXE,VXE/A,VXEB,VXEB/A,VXQ4 VXQ4/A,VXQ7,VXQ7/A,VXU,VXU/A,VXU1,VXU1/A,WKD6,WKD6/A,WKT2,WKT2/A WKT4,WKT4/A
16	96100-62020-00	BEARING, RADIAL BALL, 6202 ..	1	-	-		HA,HAQ,HA2,HA2/A,LJS,LJS/A,LK,LKS,LKS/A,PA,PAE,PA2,PA2/A,QA,QAB2 QAB2/A,QAE,QAE2,QAE2/A,QAG2,QAG2/A,QAQ,QAQ4,QAR2,QAR2/A,QA2,QA2/A QC12,QC12/A,QKA2,QW24,RA,RA2,RA2/A,RSC2,RTB2,RTB2/A,SK,VA,VAH1 VA2,VA2/A,VH12,VH12/A,VMT2,VTA,VTA2,VTA2/A,VWC2,VWC2/A EDN2/A,EDS1/A,EDS2/A,EDS6,EDS6/A,EDT1/A,EDT3,EDT6,EDT6/A,ED2/A ED5/A,EN2,EN2/A,ES1/A,ES2,ES3/A,HA2/A,HX/A,HXQ4/A,LSX/A,LX/A,LXF LXQ4/A,LX2/A,PA2/A,PMT2/A,PX/A,QAB2,QAB2/A,QAG,QAG/A,QAG2/A,QA2/A QTC2,QTC2/A,QW24,QX/A,QXB7,QXB7/A,QXC/A,QXC9/A,QXQ4/A,QXU,QXU/A Q1/A,RA2/A,RTB2/A,RX/A,RXQ4/A,SJC1/A,SJC5/A,SMS/A,SMX2/A,SNR/A SX/A,SXQ4/A,SXU,SXU/A,S1/A,VA2/A,VDG2,VDG2/A,VH12/A,VMT2,VSB1/A VS3,VS4,VTA2/A,VWC2/A,VX/A,VXB/A,VXB7,VXB7/A,VXE,VXE/A,VXEB,VXEB/A VXQ4/A,VXQ7,VXQ7/A,VXU,VXU/A,VXU1,VXU1/A,WKD6,WKD6/A,WKT2,WKT2/A WKT4,WKT4/A
17	90013-883-000	BOLT, FLANGE, 6X12(CT200) ...	1	(1)	-		EDN,EDN2,EDS1,EDS2,EDS3,EDS5,EDT1,EDT2,ED2,ED5,ES1,ES3,HA2,HX HXQ4,LSX,LX,LXQ4,LX2,PA2,PMT2,PX,QAG2,QAQ4,QA2,QMX2,QX,QXC,QXC9 QXQ4,Q1,RA2,RSC2,RTB2,RX,RXQ4,SJC1,SJC5,SMS,SMX2,SNR,SX,SXQ4,S1 VA2,VH12,VMX,VSB1,VTA2,VWC2,VX,VXB,VXQ4,VXU,WKT2



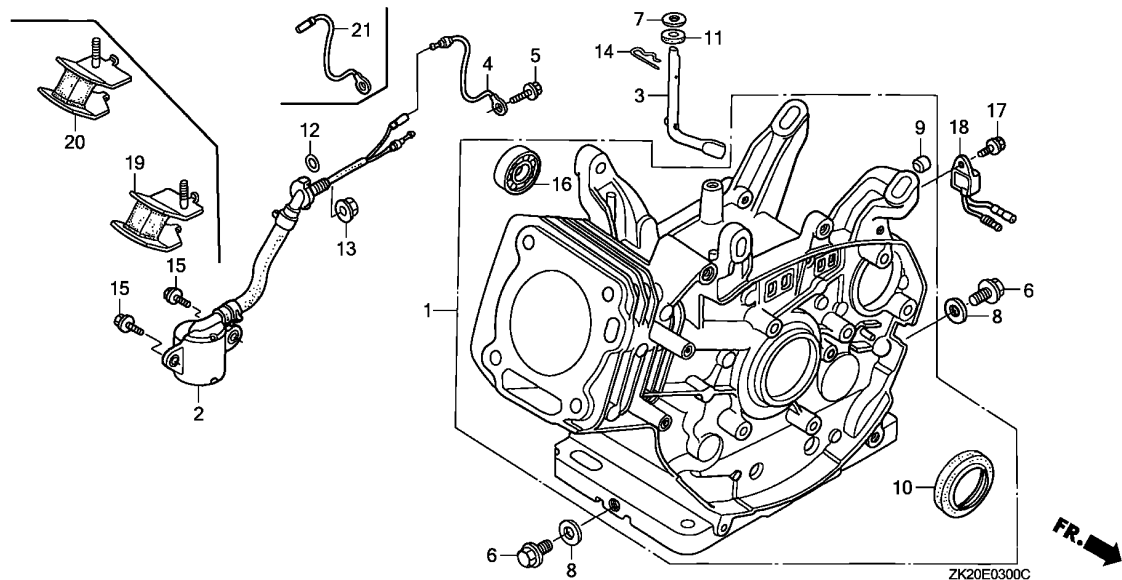

Ref. No.	Part No.	Description	Reqd. QTY			Serial No.	Parts catalogue code
			(1)	(2)	(3)		
18	34150-ZH7-003	ALERT UNIT, OIL	1	(1)	-	3684579	EDN,EDN2,EDS1,EDS2,EDS3,EDS5,EDT1,EDT2,ED2,ED5,ES1,ES3,HA2,HX HXQ4,LSX,LX,LXQ4,LX2,PA2,PMT2,PX,QAG2,QAQ4,QA2,QMX2,QX,QXC,QXC9 QXQ4,Q1,RA2,RSC2,RTB2,RX,RXQ4,SJC1,SJC5,SMS,SMX2,SNR,SX,SXQ4,S1 VA2,VH12,VMX,VSU1,VTA2,VWC2,VX,VXB,VXQ4,VXU,WKT2
			1	(1)	-	4853039	EDS1/A,EDT1/A,ES1/A,ES3/A,HX/A,LSX/A,LX/A,LXF,PX/A,QX/A,QXC/A Q1/A,RX/A,SJC1/A,SJC5/A,SMS/A,SNR/A,SX/A,S1/A,VS3,VX/A
			1	-	-		EDN2/A,EDS2/A,EDS6,EDS6/A,EDT6,EDT6/A,ED2/A,ED5/A,EN2,EN2/A,HA2/A HXQ4/A,LXQ4/A,LX2/A,PA2/A,PMT2/A,QAB2,QAB2/A,QAG,QAG/A,QAG2/A QA2/A,QTC2,QTC2/A,QW24,QXB7,QXB7/A,QXC9/A,QXQ4/A,QXU,QXU/A,RA2/A RTB2/A,RXQ4/A,SMX2/A,SXQ4/A,SXU,SXU/A,VA2/A,VDG2,VDG2/A,VH12/A VMT2,VSU1/A,VTA2/A,VWC2/A,VXB/A,VXB7,VXB7/A,VXQ4/A,VXQ7,VXQ7/A VXU/A,VXU1,VXU1/A,WKD6,WKD6/A,WKT2/A,WKT4,WKT4/A
	34150-ZH7-013	1	(1)	-	4853040	EDS1/A,EDT1/A,ES1/A,ES3/A,HX/A,LSX/A,LX/A,LXF,PX/A,QX/A,QXC/A Q1/A,RX/A,SJC1/A,SJC5/A,SMS/A,SNR/A,SX/A,S1/A,VS3,VX/A
			1	-	-		EDT3,ES2,VS4
19	68325-ZB4-000	RUBBER, BOTTOM	2	-	-		ES,ES1,ES1/A,ES2,ES3,ES3/A,VSU1,VSU1/A,VS3,VS4
20	68325-899-000	RUBBER, BOTTOM	2	-	-		ES,ES1,ES1/A,ES2,ES3,ES3/A,VSU1,VSU1/A,VS3,VS4
21	31161-ZE2-000	CORD, EARTH	1	-	-		EDN2/A,ES3/A,VSU1,VSU1/A,VS3,VS4
			1	-	-	3566260	EDN,EDN2,ES3,ETS

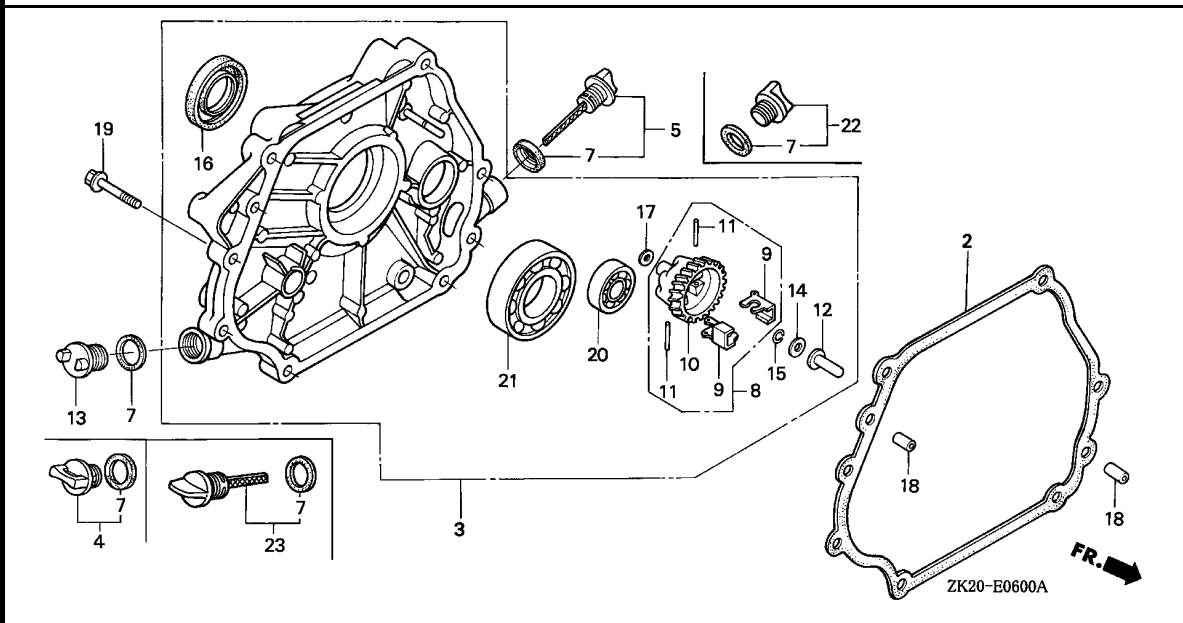

Ref. No.	L.O.N.	(Relative ref. Number) Description	F.R.T.
2	1101E9	PACKING, CRANKCASE COVER	0.2
3	1101F1	COVER, CRANKCASE	0.2
10		(9,11)	
	1161A7	HOLDER, GOVERNOR WEIGHT	0.3
12		(14,15)	
	1161B6	SLIDER, GOVERNOR	0.3
16	1101E5	OIL SEAL, CRANKSHAFT :REAR ...	0.3
20	1101F5	BEARING, BALANCER WEIGHT :REAR	0.4
21	1101A6	BEARING, CRANKSHAFT :REAR	0.4

Ref. No.	Part No.	Description	Reqd. QTY			Serial No.	Parts catalogue code				
			(1)	(2)	(3)						
2	11381-ZE2-801	PACKING, CASE COVER	1	(1)	-	EDN,EDS,EDS1,EDS1/A,EDS2,EDS2/A,EDS3,EDS5,EDS6,EDS6/A,EDT1,EDT1/A,EDT2,EDT3,EDT6,EDT6/A,ED2,ED2/A,ED3,ED4,ED4/A,ED5,ED5/A,EN,EN2,EN2/A,ET,ETS,ETX,PA,PA2,PA2/A,PX,PX/A,P1,QA,QAB2,QAB2/A,QAE,QAE2,QAE2/A,QAG,QAG/A,QAG2,QAG2/A,QAQ,QAQ4,QAR2,QAR2/A,QA2,QA2/A,QC12,QC12/A,QD,QD/A,QDA,QE,QE/A,QH,QH/A,QHB2,QHC,QHE,QHP1,QHP1/A,QHQ4,QHQ4/A,QHZ,QKA2,QMH,QMH/A,QMX2,QP,QP/A,QT,QT/A,QTC2,QTC2/A,QW24,QX,QX/A,QXB,QXB7,QXB7/A,QXC,QXC/A,QXE,QXE/A,QXEB,QXE4,QXE4/A,QXQ4,QXQ4/A,QXU,QXU/A,Q1,Q1/A,RA,RA2,RA2/A,RD,RD/A,RH,RHE,RHE4,RHQ4,RHQ4/A,RJ,RJ/A,RSC2,RSS1,RSS1/A,RTB2,RTB2/A,RX,RX/A,RXQ4,RXQ4/A,R1,R1/A,SD,SD/A,SDB1,SDB3,SDB3/A,SE,SE/A,SH,SHE,SHEZ,SHW,SHW/A,SJ,SJ/A,SJC,SJC1,SJC1/A,SJC5,SJC5/A,SJG,SJG/A,SJP,SK,SMS,SMS/A,SNC1,SNE1,SNR,SNR/A,STP,STP/A,STQ,STQ/A,SW,SWE,SX,SX/A,AXB,SXE,SXEB,SXE4,SXE4/A,SXQ4,SXQ4/A,SXU,SXU/A,S1,S1/A,VA,VAH1,VA2,VA2/A,VDG2,VDG2/A,VH,VH/A,VH12,VH12/A,VMT2,VMX,VNG,VSB1/A,VS3,VS4,VTA,VTA2,VTA2/A,VTE2,VWC2,VWC2/A,VX,VX/A,VXB,VXB/A,VXB7,VXB7/A,VXE,VXE/A,VXEB,VXEB/A,VXQ4,VXQ4/A,VXQ7,VXQ7/A,VXU,VXU/A,VXU1,VXU1/A,V1,WH,WJ,WJ/A,WKA,WKD6,WKD6/A,WKT2,WKT2/A,WKT4,WKT4/A,WMK,W1,W1/A	1	-	-	3634565	VSB1
3	11300-ZE2-000	COVER ASSY., CRANKCASE	1	1	-	4211335	RD,RHQ4,RJ,RSS1,RX,RXQ4,R1,SD,SDB3,SE,SJ,SJC1,SJC5,SJG,SMS,SNR,STP,STQ,SX,SXE4,SXQ4,SXU,S1				
	11300-ZE2-600	1	1	1	4211335	EDN,RH,RHE,RHE4,SDB1,SH,SHE,SHEZ,SJC,SJP,SNC1,SNE1,SW,SWE,SXB,SXE,SXEB				
	11300-ZE2-630	1	1	-	4211335	P1,QDA,QHC,QHE,QHZ,QMX2,QXB,QXEB,VMX,VNG,VXQP,V1				
		1	1	-	4211335	PX,QD,QE,QH,QHP1,QHQ4,QMH,QP,QT,QTC2,QX,QXC,QXE,QXE4,QXQ4,QXU,Q1,VDG2,VH,VX,VXB,VXE,VXEB,VXQ4,VXU,VXU1				
		1	-	-	3634565	4211335				
		1	1	-	4211335	EDS1,EDS2,EDS6,EDT1,EDT6,ED2,ED4,ED5,EN2,WJ,WKD6,WKT2,WKT4,W1				
		1	-	-	4211335	EDS,EDS3,EDS5,EDT2,ED3,EN,ET,ETS,ETX,VTE2,WH,WKA				



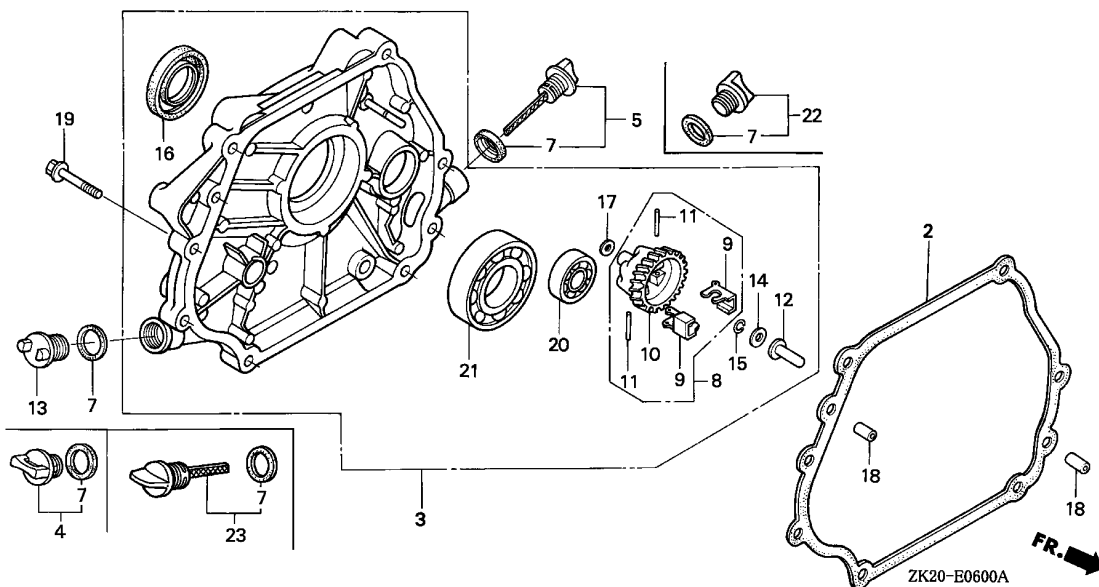

Ref. No.	Part No.	Description	Reqd. QTY			Serial No.	Parts catalogue code
			(1)	(2)	(3)		
(3)	11400-ZE2-010	COVER ASSY., CRANKCASE	1	-	-	RA,RSC2,SK	
	11400-ZE2-601	1	-	-	4211335 RA2,RTB2	
	11300-ZE2-010	1	-	-	PA,PAE,QA,QAE,QAQ,QAQ4,QKA2,VA,VAH1,VTA	
	11300-ZE2-601	1	1	-	3156815 VH12	
	11300-ZE2-601	1	1	-	4211335 PA2,QAB2,QAE2,QAG2,QAR2,QA2,QC12,VA2,VTA2,VWC2	
	11300-ZE2-631	1	1	-	4211336 RD,RHQ4,RJ,RSS1,RX,RXQ4,R1,SD,SDB3,SE,SJ,SJC1,SJC5,SJG,SMS,SNR	
	11400-ZE2-020	1	-	-	STP,STQ,SX,SXE4,SXQ4,SXU,S1	
	11400-ZE2-602	1	-	-	SHW	
	11400-ZE2-670	1	-	-	PX,QD,QE,QH,QHP1,QHQ4,QMH,QP,QT,QTC2,QX,QXC,QXE,QXE4,QXQ4,QXU,Q1	
	11300-ZE2-020	1	1	-	VDG2,VH,VSB1,VX,VXB,VXE,VXEB,VXQ4,VXU,VXU1	
	11300-ZE2-602	1	-	-	QAG,QXB7,VXB7,VXP,VXQ7	
	11300-ZE2-632	1	1	-	EDS1,EDS2,EDS6,EDT1,EDT6,ED2,ED4,ED5,EN2,WJ,WKD6,WKT2,WKT4,W1	
	11300-ZH9-S50	1	-	-	RA2,RTB2	
	11400-ZE2-030	1	-	-	PA2,QAB2,QAE2,QAG2,QAR2,QA2,QC12,VA2,VTA2,VWC2	
	11400-ZE2-603	1	1	-	3156816 4211335 VH12	
		1	1	-	RD/A,RHQ4/A,RJ/A,RSS1/A,RX/A,RXQ4/A,R1/A,SD/A,SDB3/A,SE/A,SHW/A	
		1	1	1	SJ/A,SJC1/A,SJC5/A,SJG/A,SMS/A,SNR/A,STP/A,STQ/A,SX/A,SXE4/A	
		1	1	1	SXQ4/A,SXU/A,S1/A	
		1	1	1	PX/A,QAG/A,QD/A,QE/A,QH/A,QHB2,QHP1/A,QHQ4/A,QMH/A,QP/A,QT/A	
		1	1	1	QTC2/A,QX/A,QXB7/A,QXC/A,QXE/A,QXE4/A,QXQ4/A,QXU/A,Q1/A,VDG2/A	
		1	1	1	VH/A,VSB1/A,VX/A,VXB/A,VXB7/A,VXE/A,VXEB/A,VXP/A,VXQ4/A,VXQ7/A	
		1	1	1	VXU/A,VXU1/A	
		1	1	1	EDS1/A,EDS2/A,EDS6/A,EDT1/A,EDT3,EDT6/A,ED2/A,ED4/A,ED5/A,EN2/A	
		1	1	1	WJ/A,WKD6/A,WKT2/A,WKT4/A,WMK,W1/A	
		1	-	-	VS3,VS4	
		1	-	-	RA2/A,RTB2/A	
		1	-	-	PA2/A,QAB2/A,QAE2/A,QAG2/A,QAR2/A,QA2/A,QC12/A,QW24,VA2/A,VMT2	
		1	-	-	VTA2/A,VWC2/A	

Ref. No.	Part No.	Description	Reqd. QTY			Serial No.	Parts catalogue code						
			GX240K1										
			(1)	(2)	(3)								
(3)	11400-ZE2-671	COVER ASSY., CRANKCASE	1	-	-	-----	VH12/A						
			1	-	-	4211336	-----						
4	15600-ZG4-003	CAP ASSY., OIL FILLER	1	1	-	-----	EDS1/A,EDS2,EDS2/A,EDS3,EDS5,EDS6,EDS6/A,EDT1/A,EDT2,EDT3,EDT6 EDT6/A,ED2/A,ED4/A,ED5/A,EN2,EN2/A,PAE,PA2/A,PX/A,QAB2,QAB2/A QAE2/A,QAG,QAG/A,QAG2,QAG2/A,QAQ4,QAR2,QAR2/A,QA2/A,QC12,QC12/A QD/A,QE/A,QH/A,QHB2,QHP1,QHP1/A,QHQ4,QHQ4/A,QHZ,QKA2,QMH,QMH/A QMX2,QP/A,QT/A,QTC2,QTC2/A,QW24,QX/A,QXB7,QXB7/A,QXC/A,QXE/A,QXE4 QXE4/A,QXQ4,QXQ4/A,QXU,QXU/A,Q1/A,RA2/A,RD/A,RHE4,RHQ4,RHQ4/A RJ/A,RSC2,RSS1,RSS1/A,RTB2,RTB2/A,RX/A,RXQ4,RXQ4/A,R1/A,SD/A,SDB1 SDB3,SDB3/A,SE/A,SHW,SHW/A,SJ/A,SJC,SJC1,SJC1/A,SJC5,SJC5/A,SJG SJG/A,SNC1,SNE1,SNR/A,STP/A,STQ/A,SA/A,SXE4,SXE4/A,SXQ4,SXQ4/A SXU,SXU/A,S1/A,VA2/A,VDG2,VDG2/A,VH/A,VH12,VH12/A,VMT2,VMX,VS1/A VS3,VS4,VTA2,VTA2/A,VTE2,VWC2,VWC2/A,VX/A,VXB7,VXB7/A,VXE/A VXEB/A,VXQ4,VXQ4/A,VXQ7,VXQ7/A,VXU,VXU/A,VXU1,VXU1/A,WJ/A,WKD6 WKD6/A,WKT2,WKT2/A,WKT4,WKT4/A,WMK,W1/A EDS1,EDT1,P1,Q1,RJ,R1,SJ,SJP,SK,SNR,STP,STQ,S1,V1,WJ,WKA,W1 EDN,EDS,ED2,ED3,ED4,ED5,EN,ET,ETS,ETX,PA,PA2,PX,QA,QAE,QAE2,QAQ QA2,QD,QDA,QE,QH,QHC,QHE,QP,QT,QX,QXB,QXC,QXE,QXEB,RA,RA2,RD,RH RHE,RX,SD,SE,SH,SHE,SHEZ,SW,SWE,SX,AXB,SXE,SXEB,VA,VAH1,VA2,VH VNG,VTA,VX,VXB,VXE,VXEB,WH VS1	1	1	-	3210414	-----	
			1	-	-	2901133	-----						
			1	-	-	3634565	-----						
5	15600-735-003	CAP ASSY., OIL FILLER	1	(1)	-	-----	EDN,EDS,EDS1,EDS1/A,EDS2,EDS2/A,EDS3,EDS5,EDS6,EDS6/A,EDT1,EDT1/A EDT2,EDT3,EDT6,EDT6/A,ED2,ED2/A,ED3,ED4,ED4/A,ED5,ED5/A,EN,EN2 EN2/A,ET,ETS,ETX,PA,PAE,PA2,PA2/A,PX,PX/A,P1,QA,QAB2,QAB2/A,QAE QAE2,QAE2/A,QAG,QAG/A,QAG2,QAG2/A,QAQ,QAQ4,QAR2,QAR2/A,QA2,QA2/A QC12,QC12/A,QD,QD/A,QDA,QE,QE/A,QH,QH/A,QHB2,QHC,QHE,QHP1,QHP1/A QHQ4,QHQ4/A,QHZ,QKA2,QMH,QMH/A,QMX2,QP,QP/A,QT,QT/A,QTC2,QTC2/A QW24,QX,QX/A,QXB,QXB7,QXB7/A,QXC,QXC/A,QXE,QXE/A,QXEB,QXE4,QXE4/A QXQ4,QXQ4/A,QXU,QXU/A,Q1,Q1/A,RA,RA2,RA2/A,RD,RD/A,RH,RHE,RHE4 RHQ4,RHQ4/A,RJ,RJ/A,RSC2,RSS1,RSS1/A,RTB2,RTB2/A,RX,RX/A,RXQ4 RXQ4/A,R1,R1/A,SD,SD/A,SDB1,SDB3,SDB3/A,SE,SE/A,SH,SHE,SHEZ,SHW SHW/A,SJ,SJ/A,SJC,SJC1,SJC1/A,SJC5,SJC5/A,SJG,SJG/A,SJP,SK,SNC1 SNE1,SNR,SNR/A,STP,STP/A,STQ,STQ/A,SW,SWE,SX,SA/A,SXB,SXE,SXEB SXE4,SXE4/A,SXQ4,SXQ4/A,SXU,SXU/A,S1,S1/A,VA,VAH1,VA2,VA2/A,VDG2 VDG2/A,VH,VH/A,VH12,VH12/A,VMT2,VMX,VNG,VS1/A,VS3,VS4,VTA,VTA2 VTA2/A,VTE2,VWC2,VWC2/A,VX,VX/A,VXB,VXB/A,VXB7,VXB7/A,VXE,VXE/A VXEB,VXEB/A,VXQ4,VXQ4/A,VXQ7,VXQ7/A,VXU,VXU/A,VXU1,VXU1/A,V1,WH WJ,WJ/A,WKA,WKD6,WKD6/A,WKT2,WKT2/A,WKT4,WKT4/A,WMK,W1,W1/A VS1	1	-	-	3634565	-----	
			-	-	1								



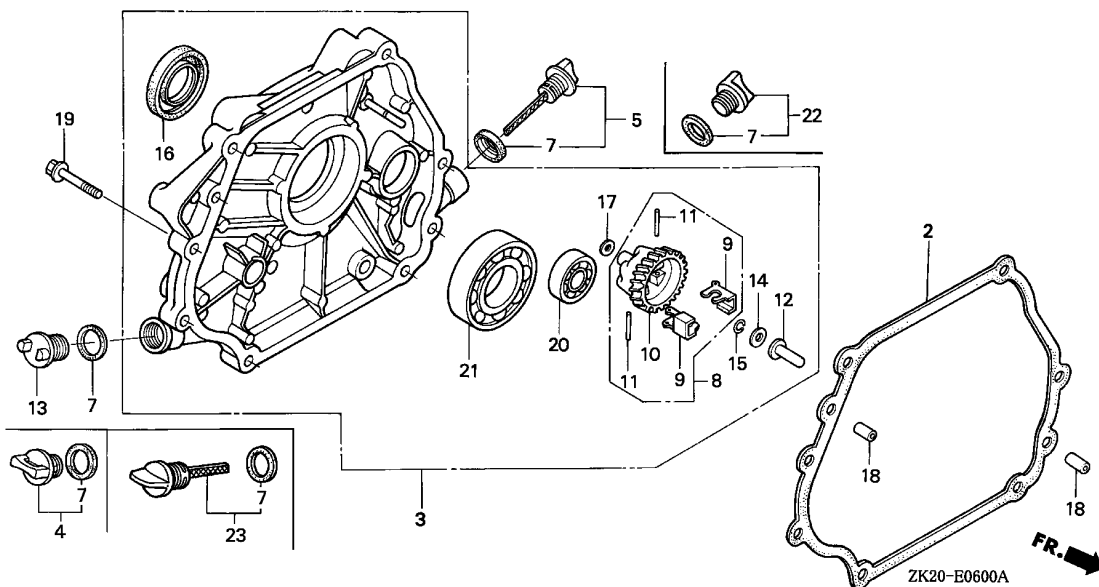

Ref. No.	Part No.	Description	Reqd. QTY			Serial No.	Parts catalogue code
			(1)	(2)	(3)		
7	15625-ZE1-003	PACKING, OIL FILLER CAP	2	1	-	-----	EDN,EDS,EDS1,EDS1/A,EDS2,EDS2/A,EDS3,EDS5,EDS6,EDS6/A,EDT1,EDT1/A,EDT2,EDT3,EDT6,EDT6/A,ED2,ED2/A,ED3,ED4,ED4/A,ED5,ED5/A,EN,EN2,EN2/A,ET,ETS,ETX,PA,PAE,PA2,PA2/A,PX,PX/A,P1,QA,QAB2,QAB2/A,QAE,QAE2,QAE2/A,QAG,QAG/A,QAG2,QAG2/A,QAQ,QAQ4,QAR2,QAR2/A,QA2,QA2/A,QC12,QC12/A,QD,QD/A,QDA,QE,QE/A,QH,QH/A,QHB2,QHC,QHE,QHP1,QHP1/A,QHQ4,QHQ4/A,QHZ,QKA2,QMH,QMH/A,QMX2,QP,QP/A,QT,QT/A,QT2,QT2/A,QW24,QX,QX/A,QXB,QXB7,QXB7/A,QXC,QXC/A,QXE,QXE/A,QXEB,QXE4,QXE4/A,QXQ4,QXQ4/A,QXU,QXU/A,Q1,Q1/A,RA,RA2,RA2/A,RD,RD/A,RH,RHE,RHE4,RHQ4,RHQ4/A,RJ,RJ/A,RSC2,RSS1,RSS1/A,RTB2,RTB2/A,RX,RX/A,RXQ4,RXQ4/A,R1,R1/A,SD,SD/A,SDB1,SDB3,SDB3/A,SE,SE/A,SH,SHE,SHEZ,SHW,SHW/A,SJ,SJ/A,SJC,SJC1,SJC1/A,SJC5,SJC5/A,SJG,SJG/A,SJP,SK,SMS,SMS/A,SNC1,SNE1,SNR,SNR/A,STP,STP/A,STQ,STQ/A,SW,SWE,SX,SX/A,SXB,SXE,SXEB,SXE4,SXE4/A,SXQ4,SXQ4/A,SXU,SXU/A,S1,S1/A,VA,VAH1,VA2,VA2/A,VDG2,VDG2/A,VH,VH/A,VH12,VH12/A,VMT2,VMX,VNG,VS1/A,VS3,VS4,VTA,VTA2,VTA2/A,VTE2,VVC2,VVC2/A,VX,VX/A,VXB,VXB/A,VXB7,VXB7/A,VXE,VXE/A,VXEB,VXEB/A,VXQ4,VXQ4/A,VXQ7,VXQ7/A,VXU,VXU/A,VXU1,VXU1/A,V1,WH,WJ,WJ/A,WKA,WKD6,WKD6/A,WKT2,WKT2/A,WKT4,WKT4/A,WMK,W1,W1/A
			2	-	-	3634565	----- VSB1
			-	-	2		
			2	(1)	-	-----	EDT3,P1,Q1,Q1/A,R1,R1/A,S1,S1/A,VS4,V1,W1,W1/A

Ref. No.	Part No.	Description	Reqd. QTY			Serial No.	Parts catalogue code
			(1)	(2)	(3)		
8	16510-ZE2-000	GOVERNOR ASSY.	1	1	-	-----	EDN,EDS,EDS1,EDS1/A,EDS2,EDS2/A,EDS3,EDS5,EDS6,EDS6/A,EDT1,EDT1/A,EDT2,EDT3,EDT6,EDT6/A,ED2,ED2/A,ED3,ED4,ED4/A,ED5,ED5/A,EN,EN2,EN2/A,ET,ETS,ETX,PX,PX/A,P1,QAG,QAG/A,QD,QD/A,QDA,QE,QA,QH,QH/A,QHB2,QHC,QHE,QHP1,QHP1/A,QHQ4,QHQ4/A,QHZ,QMH,QMH/A,QMX2,QP,QP/A,QT,QT/A,QTC2,QTC2/A,QX,QX/A,QXB,QXB7,QXB7/A,QXC,QXC/A,QXE,QXE/A,QXEB,QXE4,QXE4/A,QXQ4,QXQ4/A,QXU,QXU/A,Q1,Q1/A,RD,RD/A,RH,RHE,RHE4,RHQ4,RHQ4/A,RJ,RJ/A,RSS1,RSS1/A,RX,RX/A,RXQ4,RXQ4/A,R1,R1/A,SD,SD/A,SDB1,SDB3,SDB3/A,SE,SE/A,SH,SHE,SHEZ,SHW,SHW/A,SJ,SJ/A,SJC,SJC1,SJC1/A,SJC5,SJC5/A,SJG,SJG/A,SJP,SMS,SMS/A,SNC1,SNE1,SNR,SNR/A,STP,STP/A,STQ,STQ/A,SW,SWE,SX,SX/A,SXB,SXE,SXE4,SXE4/A,SXQ4,SXQ4/A,SXU,SXU/A,S1,S1/A,VDG2,VDG2/A,VH,VH/A,VMX,VNG,VSB1/A,VS3,VS4,VTE2,VX,VX/A,VXB,VXB/A,VXB7,VXB7/A,VXE,VXE/A,VXEB,VXEB/A,VXQ4,VXQ4/A,VXQ7,VXQ7/A,VXU,VXU/A,VXU1,VXU1/A,V1,WH,WJ,WJ/A,WKA,WKD6,WKD6/A,WKT2,WKT2/A,WKT4,WKT4/A,WMK,W1,W1/A
			1	-	-	3634565	----- VSB1
	16510-ZE2-811	1	-	-	-----	PA,PAE,PA2,PA2/A,QA,QAB2,QAB2/A,QAE,QAE2,QAE2/A,QAG2,QAG2/A,QAQ,QAQ4,QAR2,QAR2/A,QA2,QA2/A,QC12,QC12/A,QKA2,QW24,RA,RA2,RA2/A,RSC2,RTB2,RTB2/A,SK,VA,VAH1,VA2,VA2/A,VMT2,VTA,VTA2,VTA2/A,VWC2,VWC2/A
	16510-ZE3-000	1	-	-	3156815	----- VH12
			1	-	-	-----	VH12/A
			1	-	-	3156816	----- VH12
9	16511-ZE2-000	WEIGHT, GOVERNOR	2	2	-	-----	EDN,EDS,EDS1,EDS1/A,EDS2,EDS2/A,EDS3,EDS5,EDS6,EDS6/A,EDT1,EDT1/A,EDT2,EDT3,EDT6,EDT6/A,ED2,ED2/A,ED3,ED4,ED4/A,ED5,ED5/A,EN,EN2,EN2/A,ET,ETS,ETX,PA,PAE,PA2,PA2/A,PX,PX/A,P1,QA,QAB2,QAB2/A,QAE,QAE2,QAE2/A,QAG,QAG/A,QAG2,QAG2/A,QAQ,QAQ4,QAR2,QAR2/A,QA2,QA2/A,QC12,QC12/A,QD,QD/A,QDA,QE,QA,QH,QH/A,QHB2,QHC,QHE,QHP1,QHP1/A,QHQ4,QHQ4/A,QHZ,QKA2,QMH,QMH/A,QMX2,QP,QP/A,QT,QT/A,QTC2,QTC2/A,QW24,QX,QX/A,QXB,QXB7,QXB7/A,QXC,QXC/A,QXE,QXE/A,QXEB,QXE4,QXE4/A,QXQ4,QXQ4/A,QXU,QXU/A,Q1,Q1/A,RA,RA2,RA2/A,RD,RD/A,RH,RHE,RHE4,RHQ4,RHQ4/A,RJ,RJ/A,RSC2,RSS1,RSS1/A,RTB2,RTB2/A,RX,RX/A,RXQ4,RXQ4/A,R1,R1/A,SD,SD/A,SDB1,SDB3,SDB3/A,SE,SE/A,SH,SHE,SHEZ,SHW,SHW/A,SJ,SJ/A,SJC,SJC1,SJC1/A,SJC5,SJC5/A,SJG,SJG/A,SJP,SK,SMS,SMS/A,SNC1,SNE1,SNR,SNR/A,STP,STP/A,STQ,STQ/A,SW,SWE,SX,SX/A,SXB,SXE,SXE4,SXE4/A,SXQ4,SXQ4/A,SXU,SXU/A,S1,S1/A,VA,VAH1,VA2,VA2/A,VDG2,VDG2/A,VH,VH/A,VMT2,VMX,VNG,VSB1/A,VS3,VS4,VTA,VTA2,VTA2/A,VTE2,VWC2,VWC2/A,VX,VX/A,VXB,VXB/A,VXB7,VXB7/A,VXE,VXE/A,VXEB,VXEB/A,VXQ4,VXQ4/A,VXQ7,VXQ7/A,VXU,VXU/A,VXU1,VXU1/A,V1,WH,WJ,WJ/A,WKA,WKD6,WKD6/A,WKT2,WKT2/A,WKT4,WKT4/A,WMK,W1,W1/A
			2	-	-	3634565	----- VSB1
			2	-	-	3156815	----- VH12
			-	-	2	-----	
	16511-ZE8-000	3	-	-	-----	VH12/A
			3	-	-	3156816	----- VH12



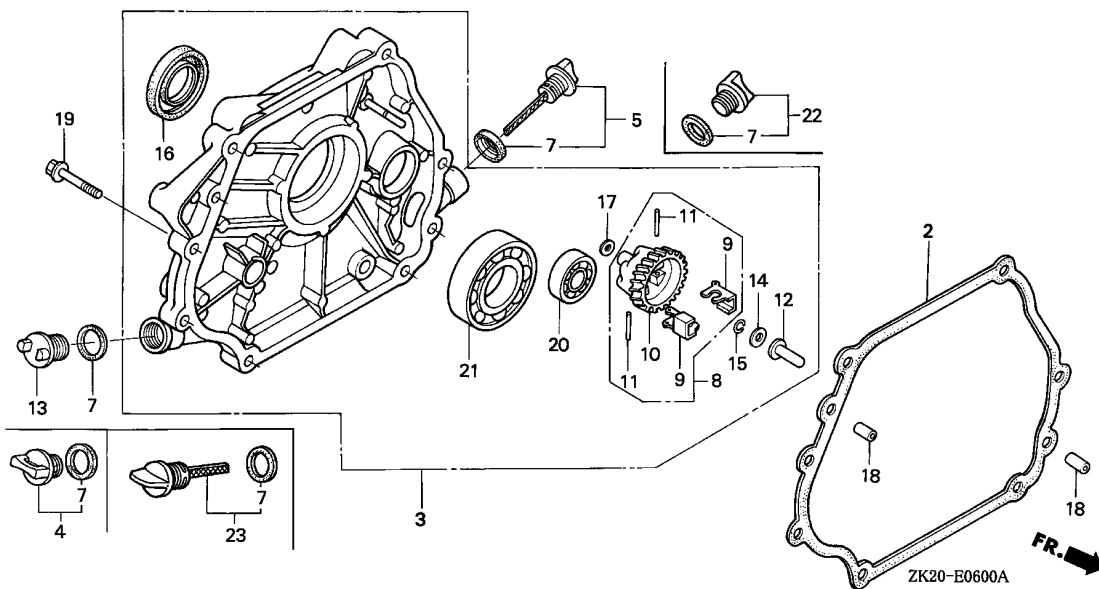

Ref. No.	Part No.	Description	Reqd. QTY			Serial No.	Parts catalogue code
			(1)	(2)	(3)		
10	16512-ZE2-000	HOLDER, GOVERNOR WEIGHT	1	1	-	-----	EDN,EDS,EDS1,EDS1/A,EDS2,EDS2/A,EDS3,EDS5,EDS6,EDS6/A,EDT1,EDT1/A,EDT2,EDT3,EDT6,EDT6/A,ED2,ED2/A,ED3,ED4,ED4/A,ED5,ED5/A,EN,EN2,EN2/A,ET,ETS,ETX,PX,PX/A,P1,QAG,QAG/A,QD,QD/A,QDA,QE,QE/A,QH,QH/A,QHB2,QHC,QHE,QHP1,QHP1/A,QHQ4,QHQ4/A,QHZ,QMH,QMH/A,QMX2,QP,QP/A,QT,QT/A,QTC2,QTC2/A,QX,QX/A,QXB,QXB7,QXB7/A,QXC,QXC/A,QXE,QXE/A,QXEB,QXE4,QXE4/A,QXQ4,QXQ4/A,QXU,QXU/A,Q1,Q1/A,RD,RD/A,RH,RHE,RHE4,RHQ4,RHQ4/A,RJ,RJ/A,RSS1,RSS1/A,RX,RX/A,RXQ4,RXQ4/A,R1,R1/A,SD,SD/A,SDB1,SDB3,SDB3/A,SE,SE/A,SH,SHE,SHEZ,SHW,SHW/A,SJ,SJ/A,SJC,SJC1,SJC1/A,SJC5,SJC5/A,SJG,SJG/A,SJP,SMS,SMS/A,SNC1,SNE1,SNR,SNR/A,STP,STP/A,STQ,STQ/A,SW,SWE,SX,SX/A,SXB,SXE,SXEB,SXE4,SXE4/A,SXQ4,SXQ4/A,SXU,SXU/A,S1,S1/A,VDG2,VDG2/A,VH,VH/A,VMX,VNG,VS1/A,VS3,VS4,VTE2,VX,VX/A,VXB,VXB/A,VXB7,VXB7/A,VXE,VXE/A,VXEB,VXEB/A,VXQ4,VXQ4/A,VXQ7,VXQ7/A,VXU,VXU/A,VXU1,VXU1/A,V1,WH,WJ,WJ/A,WKA,WKD6,WKD6/A,WKT2,WKT2/A,WKT4,WKT4/A,WMK,W1,W1/A
			1	-	-	3634565	----- VSB1
			-	-	1		
	16512-ZE2-811	1	-	-	-----	PA,PAE,PA2,PA2/A,QA,QAB2,QAB2/A,QAE,QAE2,QAE2/A,QAG2,QAG2/A,QAQ,QAQ4,QAR2,QAR2/A,QA2,QA2/A,QC12,QC12/A,QKA2,QW24,RA,RA2,RA2/A,RSC2,RTB2,RTB2/A,SK,VA,VAH1,VA2,VA2/A,VMT2,VTA,VTA2,VTA2/A,VWC2/A
			1	-	-	3156815	----- VH12
	16512-ZE3-000	1	-	-	-----	VH12/A
			1	-	-	3156816	----- VH12

Ref. No.	Part No.	Description	Reqd. QTY			Serial No.	Parts catalogue code
			(1)	(2)	(3)		
11	16513-ZE2-000	PIN, GOVERNOR WEIGHT	2	2	-		EDN,EDS,EDS1,EDS1/A,EDS2,EDS2/A,EDS3,EDS5,EDS6,EDS6/A,EDT1,EDT1/A,EDT2,EDT3,EDT6,EDT6/A,ED2,ED2/A,ED3,ED4,ED4/A,ED5,ED5/A,EN,EN2,EN2/A,ET,ETS,ETX,PA,PAE,PA2,PA2/A,PX,PX/A,P1,QA,QAB2,QAB2/A,QAE,QAE2,QAE2/A,QAG,QAG/A,QAG2,QAG2/A,QAQ,QAQ4,QAR2,QAR2/A,QA2,QA2/A,QC12,QC12/A,QD,QD/A,QDA,QE,QE/A,QH,QH/A,QHB2,QHC,QHE,QHP1,QHP1/A,QHQ4,QHQ4/A,QHZ,QKA2,QMH,QMH/A,QMX2,QP,QP/A,QT,QT/A,QTC2,QTC2/A,QW24,QX,QX/A,QXB,QXB7,QXB7/A,QXC,QXC/A,QXE,QXE/A,QXEB,QXE4,QXE4/A,QXQ4,QXQ4/A,QXU,QXU/A,Q1,Q1/A,RA,RA2,RA2/A,RD,RD/A,RH,RHE,RHE4,RHQ4,RHQ4/A,RJ,RJ/A,RSC2,RSS1,RSS1/A,RTB2,RTB2/A,RX,RX/A,RXQ4,RXQ4/A,R1,R1/A,SD,SD/A,SDB1,SDB3,SDB3/A,SE,SE/A,SH,SHE,SHEZ,SHW,SHW/A,SJ,SJ/A,SJC,SJC1,SJC1/A,SJC5,SJC5/A,SJG,SJG/A,SJP,SK,SMS,SMS/A,SNC1,SNE1,SNR,SNR/A,STP,STP/A,STQ,STQ/A,SW,SWE,SX,SX/A,AXB,SXE,SXE,SXE4,SXE4/A,SXQ4,SXQ4/A,SXU,SXU/A,S1,S1/A,VA,VAH1,VA2,VA2/A,VDG2,VDG2/A,VH,VH/A,VMT2,VMX,VNG,VSB1/A,VS3,VS4,VTA,VTA2,VTA2/A,VTE2,VWC2,VWC2/A,VX,VX/A,VXB,VXB/A,VXB7,VXB7/A,VXE,VXE/A,VXEB,VXEB/A,VXQ4,VXQ4/A,VXQ7,VXQ7/A,VXU,VXU/A,VXU1,VXU1/A,V1,WH,WJ,WJ/A,WKA,WKD6,WKD6/A,WKT2,WKT2/A,WKT4,WKT4/A,WMK,W1,W1/A
			2	-	-	3634565	----- VSB1
			2	-	-	3156815	----- VH12
			-	-	2		
			2	-	-		----- EDT3,VS4
			3	-	-		----- VH12/A
			3	-	-	3156816	----- VH12
12	16531-ZE2-000	SLIDER, GOVERNOR	1	1	-	4211335	EDS1,EDS2,EDS6,EDT1,EDT6,ED2,ED4,ED5,EN2,PA2,PX,QAB2,QAE2,QAG2,QAR2,QA2,QC12,QD,QE,QH,QHP1,QHQ4,QMH,QP,QT,QTC2,QX,QXC,QXE,QXE4,QXQ4,QXU,Q1,RA2,RD,RHQ4,RJ,RSS1,RTB2,RX,RXQ4,R1,SD,SDB3,SE,SJ,SJC1,SJC5,SJG,SMS,SNR,STP,STQ,SX,SXE4,SXQ4,SXU,S1,VA2,VDG2,VH,VH12,VTA2,VWC2,VX,VXB,VXE,VXEB,VXQ4,VXU,VXU1,WJ,WKD6,WKT2,WKT4,W1
	16531-Z0A-000	1	-	-	3634565	4211335 VSB1
			1	1	-		EDN,EDS,EDS1/A,EDS2/A,EDS3,EDS5,EDS6/A,EDT1/A,EDT2,EDT3,EDT6/A,ED2/A,ED3,ED4/A,ED5/A,EN,EN2/A,ET,ETS,ETX,PA,PAE,PA2/A,PX/A,P1,QA,QAB2/A,QAE,QAE2/A,QAG,QAG/A,QAG2/A,QAQ,QAQ4,QAR2/A,QA2/A,QC12/A,QD/A,QDA,QE/A,QH/A,QHB2,QHC,QHE,QHP1/A,QHQ4/A,QHZ,QKA2,QMH/A,QMX2,QP/A,QT/A,QTC2/A,QW24,QX/A,QXB,QXB7,QXB7/A,QXC/A,QXE/A,QXEB,QXE4/A,QXQ4/A,QXU/A,Q1/A,RA,RA2/A,RD/A,RH,RHE,RHE4,RHQ4/A,RJ/A,RSC2,RSS1/A,RTB2/A,RX/A,RXQ4/A,R1/A,SD/A,SDB1,SDB3/A,SE/A,SH,SHE,SHEZ,SHW,SHW/A,SJ/A,SJC,SJC1/A,SJC5/A,SJG/A,SJP,SK,SMS/A,SNC1,SNE1,SNR/A,STP/A,STQ/A,SW,SWE,SX/A,AXB,SXE,SXE,SXE4/A,SXQ4/A,SXU/A,S1/A,VA,VAH1,VA2/A,VDG2/A,VH/A,VH12/A,VMT2,VMX,VNG,VSB1/A,VS3,VS4,VTA,VTA2/A,VTE2,VWC2/A,VX/A,VXB/A,VXB7/A,VXE/A,VXEB/A,VXQ4/A,VXQ7,VXQ7/A,VXU/A,VXU1/A,V1,WH,WJ/A,WKA,WKD6/A,WKT2/A,WKT4/A,WMK,W1/A
			1	1	-	4211336	----- EDS1,EDS2,EDS6,EDT1,EDT6,ED2,ED4,ED5,EN2,PA2,PX,QAB2,QAE2,QAG2,QAR2,QA2,QC12,QD,QE,QH,QHP1,QHQ4,QMH,QP,QT,QTC2,QX,QXC,QXE,QXE4,QXQ4,QXU,Q1,RA2,RD,RHQ4,RJ,RSS1,RTB2,RX,RXQ4,R1,SD,SDB3,SE,SJ,SJC1,SJC5,SJG,SMS,SNR,STP,STQ,SX,SXE4,SXQ4,SXU,S1,VA2,VDG2,VH,VH12,VSB1,VTA2,VWC2,VX,VXB,VXE,VXEB,VXQ4,VXU,VXU1,WJ,WKD6,WKT2,WKT4,W1
13	15620-ZG4-910	CAP, OIL FILLER	-	-	1		
			1	1	-	3210413	EDS1,EDT1,P1,Q1,RJ,R1,SJ,SJP,SK,SNR,STP,STQ,S1,V1,WJ,WKA,W1
			1	-	-	2901132	EDN,EDS,ED2,ED3,ED4,ED5,EN,ET,ETS,ETX,PA,PA2,PX,QA,QAE,QAE2,QAQ,QA2,QD,QDA,QE,QH,QHC,QHE,QP,QT,QX,QXB,QXC,QXE,QXEB,RA,RA2,RD,RH,RHE,RX,SD,SE,SH,SHE,SHEZ,SW,SWE,SX,AXB,SXE,SXE,VA,VAH1,VA2,VH,VNG,VTA,VX,VXB,VXE,VXEB,WH



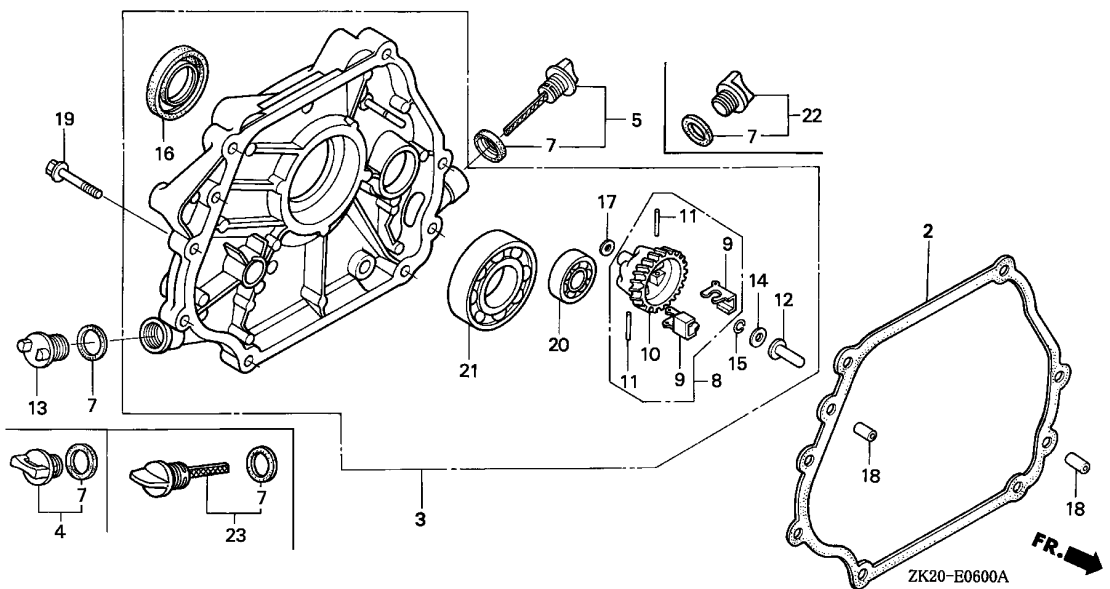

2

Ref. No.	Part No.	Description	Reqd. QTY			Serial No.	Parts catalogue code
			GX240K1				
			(1)	(2)	(3)		
14	90473-147-000	WASHER, 6X16	1	1	-	3191475	EDS1,EDT1,P1,Q1,RJ,R1,SJ,SJP,SK,SNR,STP,STQ,S1,V1,WJ,WKA,W1
			1	-	-	-----	QAQ,QDA,RSC2,VH12/A
			1	-	-	3190534	EDN,EDS,ED2,ED3,ED4,ED5,EN,ET,ETS,ETX,PX,QA,QAE,QD,QE,QH,QHC,QHE QP,QT,QX,QXB,QXE,QXEB,RD,RH,RHE,RX,SD,SE,SH,SHE,SHEZ,SW,SWE,SX SXB,SXE,SXEB,VH,VNG,VX,VXB,VXE,VXEB,WH
			(1)	-	-	3190534	PA,QXC,RA,VA,VAH1,VTA
			1	1	-	4211336	EDS1,EDS2,EDS6,EDT1,EDT6,ED2,ED4,ED5,EN2,PA2,PX,QAB2,QAE2,QAG2 QAR2,QA2,QC12,QD,QE,QH,QHP1,QHQ4,QMH,QP,QT,QTC2,QX,QXC,QXE,QXE4 QXQ4,QXU,Q1,RA2,RD,RHQ4,RJ,RSS1,RTB2,RX,RXQ4,R1,SD,SDB3,SE,SJ SJC1,SJC5,SJG,SMS,SNR,STP,STQ,SX,SXE4,SXQ4,SXU,S1,VA2,VDG2,VH VSB1,VTA2,VWC2,VX,VXB,VXE,VXEB,VXQ4,VXU,VXU1,WJ,WKD6,WKT2,WKT4,W1
			1	-	1	-----	QXB7,VH12/A,VXB7,VXP,VXQ7
			1	-	-	3156816	VH12

Ref. No.	Part No.	Description	Reqd. QTY			Serial No.	Parts catalogue code
			(1)	(2)	(3)		
15	90602-ZE1-000	CLIP, GOVERNOR HOLDER	1	1	-	-----	EDN,EDS,EDS1,EDS1/A,EDS2,EDS2/A,EDS3,EDS5,EDS6,EDS6/A,EDT1,EDT1/A,EDT2,EDT3,EDT6,EDT6/A,ED2,ED2/A,ED3,ED4,ED4/A,ED5,ED5/A,EN,EN2,EN2/A,ET,ETS,ETX,PA,PAE,PA2,PA2/A,PX,PX/A,P1,QA,QAB2,QAB2/A,QAE,QAE2,QAE2/A,QAG,QAG/A,QAG2,QAG2/A,QAQ,QAQ4,QAR2,QAR2/A,QA2,QA2/A,QC12,QC12/A,QD,QD/A,QDA,QE,QE/A,QH,QH/A,QHB2,QHC,QHE,QHP1,QHP1/A,QHQ4,QHQ4/A,QHZ,QKA2,QMH,QMH/A,QMX2,QP,QP/A,QT,QT/A,QTC2,QTC2/A,QW24,QX,QX/A,QXB,QXB7,QXB7/A,QXC,QXC/A,QXE,QXE/A,QXEB,QXE4,QXE4/A,QXQ4,QXQ4/A,QXU,QXU/A,Q1,Q1/A,RA,RA2,RA2/A,RD,RD/A,RH,RHE,RHE4,RHQ4,RHQ4/A,RJ,RJ/A,RSC2,RSS1,RSS1/A,RTB2,RTB2/A,RX,RX/A,RXQ4,RXQ4/A,R1,R1/A,SD,SD/A,SDB1,SDB3,SDB3/A,SE,SE/A,SH,SHE,SHEZ,SHW,SHW/A,SJ,SJ/A,SJC,SJC1,SJC1/A,SJC5,SJC5/A,SJG,SJG/A,SJP,SK,SMS,SMS/A,SNC1,SNE1,SNR,SNR/A,STP,STP/A,STQ,STQ/A,SW,SWE,SX,SX/A, SXB,SXE,SXEB,SXE4,SXE4/A,SXQ4,SXQ4/A,SXU,SXU/A,S1,S1/A,VA,VAH1,VA2,VA2/A,VDG2,VDG2/A,VH,VH/A,VH12,VH12/A,VMT2,VMX,VNG,VSB1/A,VS3,VS4,VTA,VTA2,VTA2/A,VTE2,VWC2,VWC2/A,VX,VX/A,VXB,VXB/A,VXB7,VXB7/A,VXE,VXE/A,VXEB,VXEB/A,VXQ4,VXQ4/A,VXQ7,VXQ7/A,VXU,VXU/A,VXU1,VXU1/A,V1,WH,WJ,WJ/A,WKA,WKD6,WKD6/A,WKT2,WKT2/A,WKT4,WKT4/A,WMK,W1,W1/A
			1	-	-	3634565	-----
	90602-896-000	(1)	-	-	-----	VS1
			-	-	1		
						-----	PA,PAE,PA2,PA2/A,QA,QAB2,QAB2/A,QAE,QAE2,QAE2/A,QAG2,QAG2/A,QAQ4,QAR2,QAR2/A,QA2,QA2/A,QC12,QC12/A,QKA2,QW24,RA,RA2,RA2/A,RTB2,RTB2/A,VA,VAH1,VA2,VA2/A,VDG2,VDG2/A,VH12,VH12/A,VMT2,VTA,VTA2,VTA2/A,VWC2,VWC2/A
16	91201-889-003	OIL SEAL, 30X45X8	1	1	-	-----	EDS,EDS1,EDS1/A,EDS2,EDS2/A,EDS3,EDS5,EDS6,EDS6/A,EDT1,EDT1/A,EDT2,EDT3,EDT6,EDT6/A,ED2,ED2/A,ED3,ED4,ED4/A,ED5,ED5/A,EN,EN2,EN2/A,ET,ETS,ETX,VTE2,WH,WJ,WJ/A,WKA,WKD6,WKD6/A,WKT2,WKT2/A,WKT4,WKT4/A,WMK,W1,W1/A
	91201-890-003	OIL SEAL, 30X46X8	1	1	-	-----	EDN,PA,PAE,PA2,PA2/A,PX,PX/A,P1,QA,QAB2,QAB2/A,QAE,QAE2,QAE2/A,QAG,QAG/A,QAG2,QAG2/A,QAQ,QAQ4,QAR2,QAR2/A,QA2,QA2/A,QC12,QC12/A,QD,QD/A,QDA,QE,QE/A,QH,QH/A,QHB2,QHC,QHE,QHP1,QHP1/A,QHQ4,QHQ4/A,QHZ,QKA2,QMH,QMH/A,QMX2,QP,QP/A,QT,QT/A,QTC2,QTC2/A,QW24,QX,QX/A,QXB,QXB7,QXB7/A,QXC,QXC/A,QXE,QXE/A,QXEB,QXE4,QXE4/A,QXQ4,QXQ4/A,QXU,QXU/A,Q1,Q1/A,RA,RA2,RA2/A,RD,RD/A,RH,RHE,RHE4,RHQ4,RHQ4/A,RJ,RJ/A,RSC2,RSS1,RSS1/A,RTB2,RTB2/A,RX,RX/A,RXQ4,RXQ4/A,R1,R1/A,SD,SD/A,SDB1,SDB3,SDB3/A,SE,SE/A,SH,SHE,SHEZ,SHW,SHW/A,SJ,SJ/A,SJC,SJC1,SJC1/A,SJC5,SJC5/A,SJG,SJG/A,SJP,SK,SMS,SMS/A,SNC1,SNE1,SNR,SNR/A,STP,STP/A,STQ,STQ/A,SW,SWE,SX,SX/A, SXB,SXE,SXEB,SXE4,SXE4/A,SXQ4,SXQ4/A,SXU,SXU/A,S1,S1/A,VA,VAH1,VA2,VA2/A,VDG2,VDG2/A,VH,VH/A,VH12,VH12/A,VMT2,VMX,VNG,VSB1/A,VS3,VS4,VTA,VTA2,VTA2/A,VWC2,VWC2/A,VX,VX/A,VXB,VXB/A,VXB7,VXB7/A,VXE,VXE/A,VXEB,VXEB/A,VXQ4,VXQ4/A,VXQ7,VXQ7/A,VXU,VXU/A,VXU1,VXU1/A,V1
			1	-	-	3634565	-----
			-	-	1		



E-6

CRANKCASE COVER(1)

F11

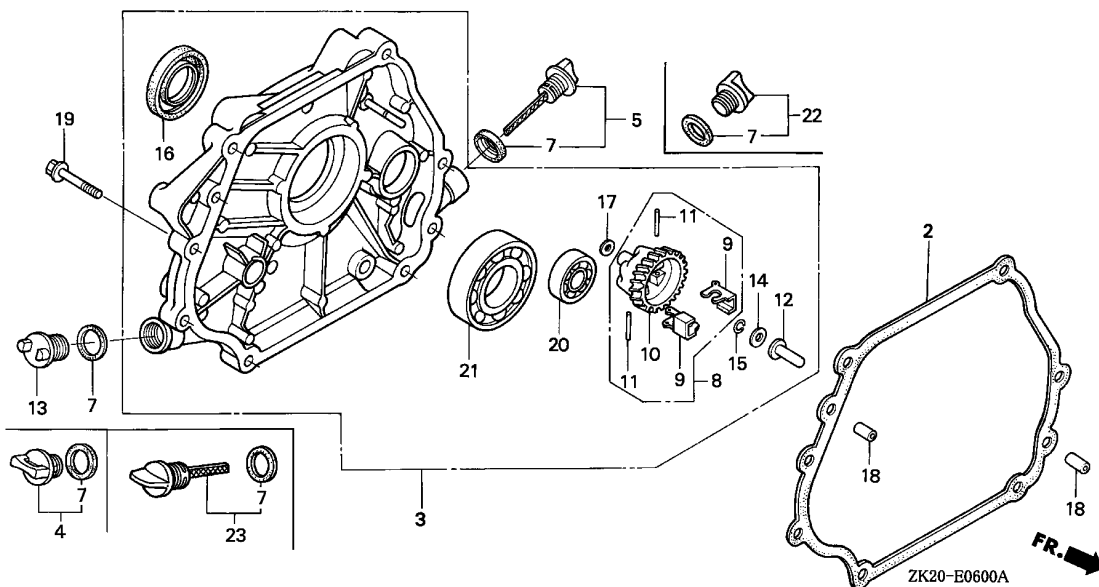

Ref. No.	Part No.	Description	Reqd. QTY			Serial No.	Parts catalogue code
			(1)	(2)	(3)		
17	94101-06800	WASHER, PLAIN, 6MM	1	1	-	EDN,EDS,EDS1,EDS1/A,EDS2,EDS2/A,EDS3,EDS5,EDS6,EDS6/A,EDT1,EDT1/A,EDT2,EDT3,EDT6,EDT6/A,ED2,ED2/A,ED3,ED4,ED4/A,ED5,ED5/A,EN,EN2,EN2/A,ET,ETS,ETX,PA,PAE,PA2,PA2/A,PX,PX/A,P1,QA,QAB2,QAB2/A,QAE,QAE2,QAE2/A,QAG,QAG/A,QAG2,QAG2/A,QAQ,QAQ4,QAR2,QAR2/A,QA2,QA2/A,QC12,QC12/A,QD,QD/A,QDA,QE,QE/A,QH,QH/A,QHB2,QHC,QHE,QHP1,QHP1/A,QHQ4,QHQ4/A,QHZ,QKA2,QMH,QMH/A,QMX2,QP,QP/A,QT,QT/A,QT2,QT2/A,QW24,QX,QX/A,QXB,QXB7,QXB7/A,QXC,QXC/A,QXE,QXE/A,QXEB,QXE4,QXE4/A,QXQ4,QXQ4/A,QXU,QXU/A,Q1,Q1/A,RA,RA2,RA2/A,RD,RD/A,RH,RHE,RHE4,RHQ4,RHQ4/A,RJ,RJ/A,RSC2,RSS1,RSS1/A,RTB2,RTB2/A,RX,RX/A,RXQ4,RXQ4/A,R1,R1/A,SD,SD/A,SDB1,SDB3,SDB3/A,SE,SE/A,SH,SHE,SHEZ,SHW,SHW/A,SJ,SJ/A,SJC,SJC1,SJC1/A,SJC5,SJC5/A,SJG,SJG/A,SJP,SK,SMS,SMS/A,SNC1,SNE1,SNR,SNR/A,STP,STP/A,STQ,STQ/A,SW,SWE,SX,SX/A,SXB,SXE,SXEB,SXE4,SXE4/A,SXQ4,SXQ4/A,SXU,SXU/A,S1,S1/A,VA,VAH1,VA2,VA2/A,VDG2,VDG2/A,VH,VH/A,VH12,VH12/A,VMT2,VMX,VNG,VSB1/A,VS3,VS4,VTA,VTA2,VTA2/A,VTE2,VVC2,VVC2/A,VX,VX/A,VXB,VXB/A,VXB7,VXB7/A,VXE,VXE/A,VXEB,VXEB/A,VXQ4,VXQ4/A,VXQ7,VXQ7/A,VXU,VXU/A,VXU1,VXU1/A,V1,WH,WJ,WJ/A,WKA,WKD6,WKD6/A,WKT2,WKT2/A,WKT4,WKT4/A,WMK,W1,W1/A	
			1	-	-	3634565	VSB1
			-	-	1		

2

Ref. No.	Part No.	Description	Reqd. QTY			Serial No.	Parts catalogue code
			(1)	(2)	(3)		
18	90701-HC4-000	DOWEL PIN, 8X12	2	2	-	-----	EDN,EDS,EDS1,EDS1/A,EDS2,EDS2/A,EDS3,EDS5,EDS6,EDS6/A,EDT1,EDT1/A,EDT2,EDT3,EDT6,EDT6/A,ED2,ED2/A,ED3,ED4,ED4/A,ED5,ED5/A,EN,EN2,EN2/A,ET,ETS,ETX,PA,PAE,PA2,PA2/A,PX,PX/A,P1,QA,QAB2,QAB2/A,QAE,QAE2,QAE2/A,QAG,QAG/A,QAG2,QAG2/A,QAQ,QAQ4,QAR2,QAR2/A,QA2,QA2/A,QC12,QC12/A,QD,QD/A,QDA,QE,QE/A,QH,QH/A,QHB2,QHC,QHE,QHP1,QHP1/A,QHQ4,QHQ4/A,QHZ,QKA2,QMH,QMH/A,QMX2,QP,QP/A,QT,QT/A,QTC2,QTC2/A,QW24,QX,QX/A,QXB,QXB7,QXB7/A,QXC,QXC/A,QXE,QXE/A,QXEB,QXE4/A,QXQ4,QXQ4/A,QXU,QXU/A,Q1,Q1/A,RA,RA2,RA2/A,RD,RD/A,RH,RHE,RHE4,RHQ4,RHQ4/A,RJ,RJ/A,RSC2,RSS1,RSS1/A,RTB2,RTB2/A,RX,RX/A,RXQ4,RXQ4/A,R1,R1/A,SD,SD/A,SDB1,SDB3,SDB3/A,SE,SE/A,SH,SHE,SHEZ,SHW,SHW/A,SJ,SJ/A,SJC,SJC1,SJC1/A,SJC5,SJC5/A,SJG,SJG/A,SJP,SK,SMS,SMS/A,SNC1,SNE1,SNR,SNR/A,STP,STP/A,STQ,STQ/A,SW,SWE,SX,SX/A,SXB,SXE,SXEB,SXE4,SXE4/A,SXQ4,SXQ4/A,SXU,SXU/A,S1,S1/A,VA,VAH1,VA2,VA2/A,VDG2,VDG2/A,VH,VH/A,VH12,VH12/A,VMT2,VMX,VNG,VSB1/A,VS3,VS4,VTA,VTA2,VTA2/A,VTE2,VWC2,VWC2/A,VX,VX/A,VXB,VXB/A,VXB7,VXB7/A,VXE,VXE/A,VXEB,VXEB/A,VXQ4,VXQ4/A,VXQ7,VXQ7/A,VXU,VXU/A,VXU1,VXU1/A,V1,WH,WJ,WJ/A,WKA,WKD6,WKD6/A,WKT2,WKT2/A,WKT4,WKT4/A,WMK,W1,W1/A
			2	-	-	3634565 -----	VSB1
19	95701-08035-00	BOLT, FLANGE, 8X35	7	7	-	-----	EDN,EDS,EDS1,EDS1/A,EDS2,EDS2/A,EDS3,EDS5,EDS6,EDS6/A,EDT1,EDT1/A,EDT2,EDT3,EDT6,EDT6/A,ED2,ED2/A,ED3,ED4,ED4/A,ED5,ED5/A,EN,EN2,EN2/A,ET,ETS,ETX,PA,PAE,PA2,PA2/A,PX,PX/A,P1,QA,QAB2,QAB2/A,QAE,QAE2,QAE2/A,QAG,QAG/A,QAG2,QAG2/A,QAQ,QAQ4,QAR2,QAR2/A,QA2,QA2/A,QC12,QC12/A,QD,QD/A,QDA,QE,QE/A,QH,QH/A,QHB2,QHC,QHE,QHP1,QHP1/A,QHQ4,QHQ4/A,QHZ,QKA2,QMH,QMH/A,QMX2,QP,QP/A,QT,QT/A,QTC2,QTC2/A,QW24,QX,QX/A,QXB,QXB7,QXB7/A,QXC,QXC/A,QXE,QXE/A,QXEB,QXE4,QXE4/A,QXQ4,QXQ4/A,QXU,QXU/A,Q1,Q1/A,RA,RA2,RA2/A,RD,RD/A,RH,RHE,RHE4,RHQ4,RHQ4/A,RJ,RJ/A,RSC2,RSS1,RSS1/A,RTB2,RTB2/A,RX,RX/A,RXQ4,RXQ4/A,R1,R1/A,SD,SD/A,SDB1,SDB3,SDB3/A,SE,SE/A,SH,SHE,SHEZ,SHW,SHW/A,SJ,SJ/A,SJC,SJC1,SJC1/A,SJC5,SJC5/A,SJG,SJG/A,SJP,SK,SMS,SMS/A,SNC1,SNE1,SNR,SNR/A,STP,STP/A,STQ,STQ/A,SW,SWE,SX,SX/A,SXB,SXE,SXEB,SXE4,SXE4/A,SXQ4,SXQ4/A,SXU,SXU/A,S1,S1/A,VA,VAH1,VA2,VA2/A,VDG2,VDG2/A,VH,VH/A,VH12,VH12/A,VMT2,VMX,VNG,VSB1/A,VS3,VS4,VTA,VTA2,VTA2/A,VTE2,VWC2,VWC2/A,VX,VX/A,VXB,VXB/A,VXB7,VXB7/A,VXE,VXE/A,VXEB,VXEB/A,VXQ4,VXQ4/A,VXQ7,VXQ7/A,VXU,VXU/A,VXU1,VXU1/A,V1,WH,WJ,WJ/A,WKA,WKD6,WKD6/A,WKT2,WKT2/A,WKT4,WKT4/A,WMK,W1,W1/A
			7	-	-	3634565 -----	VSB1
20	96100-62020-00	BEARING, RADIAL BALL, 6202 ..	1	-	-	-----	PA,PAE,PA2,PA2/A,QA,QAB2,QAB2/A,QAE,QAE2,QAE2/A,QAG2,QAG2/A,QAQ,QAQ4,QAR2,QAR2/A,QA2,QA2/A,QC12,QC12/A,QKA2,QW24,RA,RA2,RA2/A,RSC2,RTB2,RTB2/A,SK,VA,VAH1,VA2,VA2/A,VH12,VH12/A,VMT2,VTA,VTA2,VTA2/A,VWC2,VWC2/A



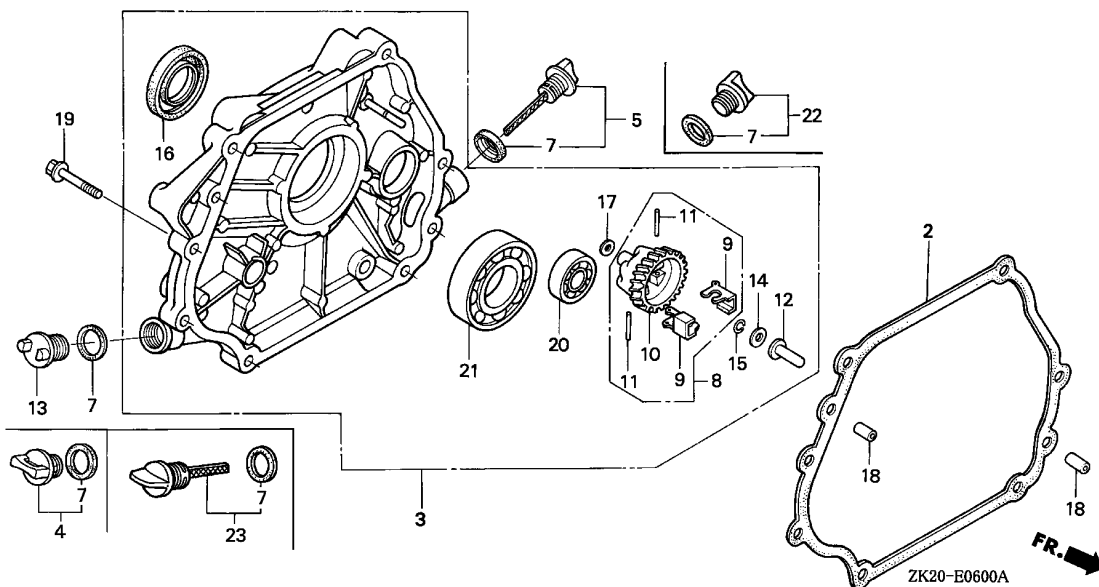

2

Ref. No.	Part No.	Description	Reqd. QTY			Serial No.	Parts catalogue code
			(1)	(2)	(3)		
21	96100-62060-00	BEARING, RADIAL BALL, 6206 ..	1	1	-	-----	EDN,EDS,EDS1,EDS1/A,EDS2,EDS2/A,EDS3,EDS5,EDS6,EDS6/A,EDT1,EDT1/A,EDT2,EDT3,EDT6,EDT6/A,ED2,ED2/A,ED3,ED4,ED4/A,ED5,ED5/A,EN,EN2,EN2/A,ET,ETS,ETX,PA,PAE,PA2,PA2/A,PX,PX/A,P1,QA,QAB2,QAB2/A,QAE,QAE2,QAE2/A,QAG,QAG/A,QAG2,QAG2/A,QAQ,QAQ4,QAR2,QAR2/A,QA2,QA2/A,QC12,QC12/A,QD,QD/A,QDA,QE,QE/A,QH,QH/A,QHB2,QHC,QHE,QHP1,QHP1/A,QHQ4,QHQ4/A,QHZ,QKA2,QMH,QMH/A,QMX2,QP,QP/A,QT,QT/A,QT2,QT2/A,QW24,QX,QX/A,QXB,QXB7,QXB7/A,QXC,QXC/A,QXE,QXE/A,QXEB,QXE4,QXE4/A,QXQ4,QXQ4/A,QXU,QXU/A,Q1,Q1/A,RA,RA2,RA2/A,RD,RD/A,RH,RHE,RHE4,RHQ4,RHQ4/A,RJ,RJ/A,RSC2,RSS1,RSS1/A,RTB2,RTB2/A,RX,RX/A,RXQ4,RXQ4/A,R1,R1/A,SD,SD/A,SDB1,SDB3,SDB3/A,SE,SE/A,SH,SHE,SHEZ,SHW,SHW/A,SJ,SJ/A,SJC,SJC1,SJC1/A,SJC5,SJC5/A,SJG,SJG/A,SJP,SK,SMS,SMS/A,SNC1,SNE1,SNR,SNR/A,STP,STP/A,STQ,STQ/A,SW,SWE,SX,SX/A,SXB,SXE,SXEB,SXE4,SXE4/A,SXQ4,SXQ4/A,SXU,SXU/A,S1,S1/A,VA,VAH1,VA2,VA2/A,VDG2,VDG2/A,VH,VH/A,VH12,VH12/A,VMT2,VMX,VNG,VS1/A,VS3,VS4,VTA,VTA2,VTA2/A,VTE2,VVC2,VVC2/A,VX,VX/A,VXB,VXB/A,VXB7,VXB7/A,VXE,VXE/A,VXEB,VXEB/A,VXQ4,VXQ4/A,VXQ7,VXQ7/A,VXU,VXU/A,VXU1,VXU1/A,V1,WH,WJ,WJ/A,WKA,WKD6,WKD6/A,WKT2,WKT2/A,WKT4,WKT4/A,WMK,W1,W1/A
			1	-	-	3634565	----- VSB1
22	15600-ZG4-003	CAP ASSY., OIL FILLER	1	-	-	-----	SMS,SMS/A
23	15600-735-003	CAP ASSY., OIL FILLER	1	-	-	-----	SMS,SMS/A

E-6-1

CRANKCASE COVER(2)

F14

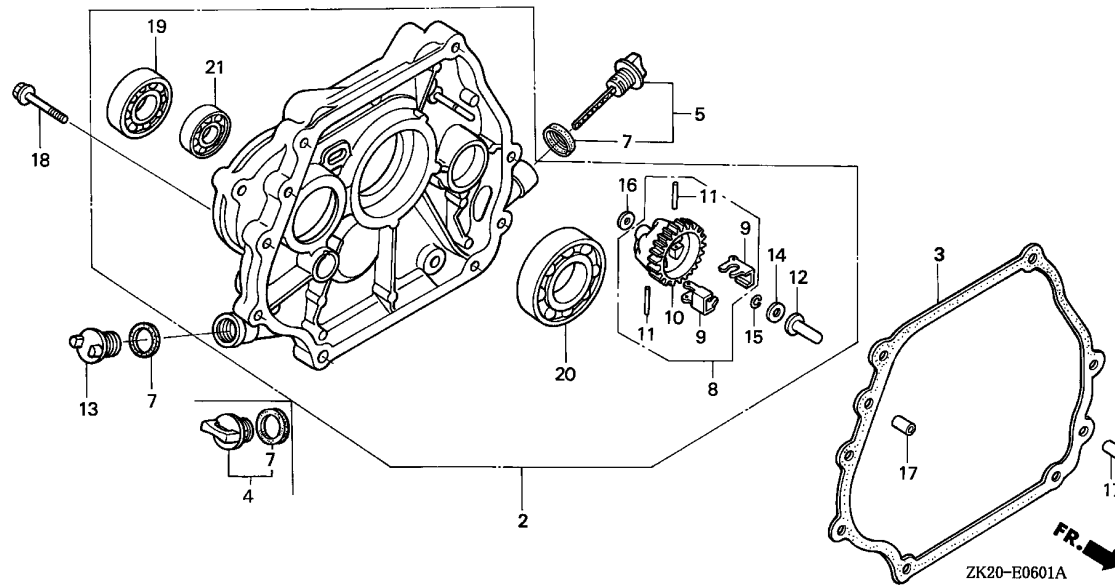

Ref. No.	L.O.N.	(Relative ref. Number) Description	F.R.T.
2	1101G0	COVER, CRANKCASE(A)	0.3
3	1101F9	PACKING, CRANKCASE COVER(A) .. (9,11)	0.3
10	1161C6	HOLDER, GOVERNOR WEIGHT(A) ... (14,15)	0.4
12	1161C7	SLIDER, GOVERNOR(A)	0.4
19	2141A7	BEARING, POWER TAKE OFF SHAFT :FRONT	0.4
20	1101G4	BEARING, CRANKSHAFT(A) :REAR ..	0.5
21	2101U3	BEARING, COUNTERSHAFT :FRONT ..	0.4

Ref. No.	Part No.	Description	Reqd. QTY			Serial No.	Parts catalogue code
			(1)	(2)	(3)		
2	11300-ZE2-620	COVER ASSY., CRANKCASE	1	-	-	-----	HTX
3	11381-ZE2-800	PACKING, CASE COVER	1	-	-	-----	HTX
4	15600-ZG4-003	CAP ASSY., OIL FILLER	1	-	-	3210414	HTX
5	15600-735-003	CAP ASSY., OIL FILLER	1	-	-	-----	HTX
7	15625-ZE1-000	PACKING, OIL FILLER CAP	2	-	-	-----	HTX
8	16510-ZE2-000	GOVERNOR ASSY.	1	-	-	-----	HTX
9	16511-ZE2-000	WEIGHT, GOVERNOR	2	-	-	-----	HTX
10	16512-ZE2-000	HOLDER, GOVERNOR WEIGHT	1	-	-	-----	HTX
11	16513-ZE2-000	PIN, GOVERNOR WEIGHT	2	-	-	-----	HTX
12	16531-Z0A-000	SLIDER, GOVERNOR	1	-	-	-----	HTX
13	15620-ZG4-910	CAP, OIL FILLER	1	-	-	3210413	HTX
14	90473-147-000	WASHER, 6X16	1	-	-	3191475	HTX
15	90602-ZE1-000	CLIP, GOVERNOR HOLDER	1	-	-	-----	HTX
16	94101-06800	WASHER, PLAIN, 6MM	1	-	-	-----	HTX
17	90701-HC4-000	DOWEL PIN, 8X12	2	-	-	-----	HTX
18	95701-08035-00	BOLT, FLANGE, 8X35	7	-	-	-----	HTX
19	96100-62040-00	BEARING, RADIAL BALL, 6204 ..	1	-	-	-----	HTX
20	96100-62060-00	BEARING, RADIAL BALL, 6206 ..	1	-	-	-----	HTX
21	96100-63020-00	BEARING, RADIAL BALL, 6302 ..	1	-	-	-----	HTX

2

E-6-2

CRANKCASE COVER(3)

F15

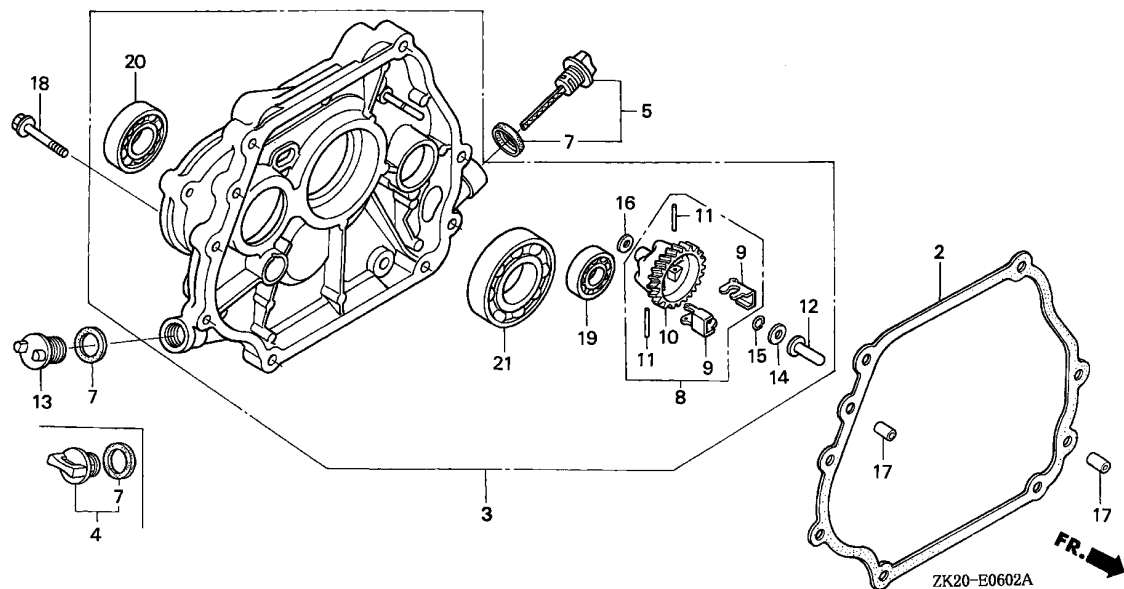

Ref. No.	L.O.N.	(Relative ref. Number) Description	F.R.T.
2	1101F9	PACKING, CRANKCASE COVER(A) ..	0.3
3	1101G0	COVER, CRANKCASE(A)	0.3
10	1161C6	HOLDER, GOVERNOR WEIGHT(A) ...	0.4
12	1161B6	SLIDER, GOVERNOR	0.3
19	1101G5	BEARING, BALANCER WEIGHT(A) :REAR	0.5
20	2141A7	BEARING, POWER TAKE OFF SHAFT :FRONT	0.4
21	1101G4	BEARING, CRANKSHAFT(A) :REAR ..	0.5

Ref. No.	Part No.	Description	Reqd. QTY			Serial No.	Parts catalogue code
			(1)	(2)	(3)		
2	11381-ZE2-801	PACKING, CASE COVER	1	-	-	-----	LK
3	11400-ZE2-611	COVER ASSY., CRANKCASE	1	-	-	-----	LK
4	15600-ZG4-003	CAP ASSY., OIL FILLER	1	-	-	3210414	LK
5	15600-735-003	CAP ASSY., OIL FILLER	1	-	-	-----	LK
7	15625-ZE1-000	PACKING, OIL FILLER CAP	2	-	-	-----	LK
8	16510-ZE2-811	GOVERNOR ASSY.	1	-	-	-----	LK
9	16511-ZE2-000	WEIGHT, GOVERNOR	2	-	-	-----	LK
10	16512-ZE2-811	HOLDER, GOVERNOR WEIGHT	1	-	-	-----	LK
11	16513-ZE2-000	PIN, GOVERNOR WEIGHT	2	-	-	-----	LK
12	16531-Z0A-000	SLIDER, GOVERNOR	1	-	-	-----	LK
13	15620-ZG4-910	CAP, OIL FILLER	1	-	-	3210413	LK
14	90473-147-000	WASHER, 6X16	1	-	-	3191475	LK
15	90602-ZE1-000	CLIP, GOVERNOR HOLDER	1	-	-	-----	LK
16	94101-06800	WASHER, PLAIN, 6MM	1	-	-	-----	LK
17	90701-HC4-000	DOWEL PIN, 8X12	2	-	-	-----	LK
18	95900-08035-00	BOLT, FLANGE, 8X35	7	-	-	-----	LK
19	96100-62020-00	BEARING, RADIAL BALL, 6202 ..	1	-	-	-----	LK
20	96100-62040-00	BEARING, RADIAL BALL, 6204 ..	1	-	-	-----	LK
21	96100-62060-00	BEARING, RADIAL BALL, 6206 ..	1	-	-	-----	LK

2

E-6-3

CRANKCASE COVER(4)

F16

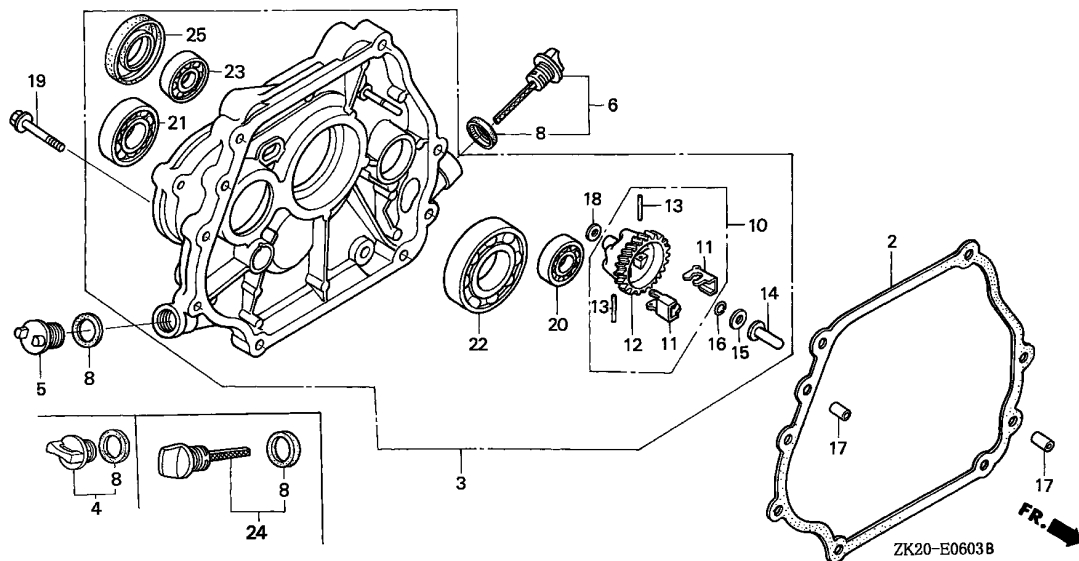

Ref. No.	L.O.N.	(Relative ref. Number) Description	F.R.T.
2	1101F9	PACKING, CRANKCASE COVER(A) ..	0.3
3	1101G0	COVER, CRANKCASE(A)	0.3
12		(11,13)	
14	1161C6	HOLDER, GOVERNOR WEIGHT(A) ...	0.4
		(15,16)	
14	1161B6	SLIDER, GOVERNOR	0.3
20	1101G5	BEARING, BALANCER WEIGHT(A)	
		:REAR	0.5
21	2141A7	BEARING, POWER TAKE OFF SHAFT	
		:FRONT	0.4
22	1101G4	BEARING, CRANKSHAFT(A) :REAR ..	0.5
23	2101U3	BEARING, COUNTERSHAFT :FRONT ..	0.4
25	1101E5	OIL SEAL, CRANKSHAFT :REAR ...	0.3

Ref. No.	Part No.	Description	Reqd. QTY			Serial No.	Parts catalogue code
			(1)	(2)	(3)		
			GX240K1				
2	11381-ZE2-801	PACKING, CASE COVER	1	1	-	-----	EDN2,EDN2/A,HA,HAQ,HA2,HA2/A,HH,HHQ4,HHQ4/A,HX,HX/A,HXQ4,HXQ4/A LD,LDB1,LDB3,LH,LH/A,LHE,LHE4,LHE4/A,LHZ,LJ,LJ/A,LJG,LJG/A,LJG1 LJS,LJS/A,LKS,LKS/A,LM9,LNJ,LNZ,LP,LP/A,LSS4,LSS5,LSS5/A,LSX LSX/A,LT,LT/A,LW,LX,LX/A,LXF,LXQ4,LXQ4/A,LXZ,LX2,LX2/A,L1,L1/A PMT2,PMT2/A,QXC9,QXC9/A,SMX2,SMX2/A
3	11300-ZE2-000	COVER ASSY., CRANKCASE	1	-	-	-----	4211335 EDN2,SMX2
	11300-ZE2-600	1	-	-	-----	4211335 PMT2,QXC9
	11300-ZE2-610	1	1	-	-----	4211335 LH,LHE4,LJ,LJG,LP,LSS5,LSX,LT,LX,LXQ4,LX2,L1
		1	-	-	-----	LD,LDB1,LDB3,LHE,LHZ,LJG1,LM9,LNJ,LNZ,LSS4,LW,LXZ
	11300-ZE2-620	1	-	-	-----	HH
		1	-	-	-----	4211335 HHQ4,HX,HXQ4
	11400-ZE2-611	1	-	-	-----	4211335 LJS,LKS
	11400-ZE2-621	1	-	-	-----	HA,HAQ
		1	-	-	-----	4211335 HA2
	11300-ZE2-010	1	-	-	4211336	EDN2,SMX2
	11300-ZE2-601	1	-	-	4211336	PMT2,QXC9
	11300-ZE2-611	1	1	-	4211336	LH,LHE4,LJ,LJG,LP,LSS5,LSX,LT,LX,LXQ4,LX2,L1
	11300-ZE2-621	1	-	-	4211336	HHQ4,HX,HXQ4
	11400-ZE2-612	1	-	-	4211336	LJS,LKS
	11400-ZE2-622	1	-	-	4211336	HA2
	11300-ZE2-020	1	-	-	-----	EDN2/A,SMX2/A
	11300-ZE2-602	1	-	-	-----	PMT2/A,QXC9/A
	11300-ZE2-612	1	1	-	-----	LH/A,LHE4/A,LJ/A,LJG/A,LP/A,LSS5/A,LSX/A,LT/A,LX/A,LXF,LXQ4/A LX2/A,L1/A
	11300-ZE2-622	1	-	-	-----	HHQ4/A,HX/A,HXQ4/A
	11400-ZE2-613	1	-	-	-----	LJS/A,LKS/A
	11400-ZE2-623	1	-	-	-----	HA2/A



E-6-3

CRANKCASE COVER(4)

G 1

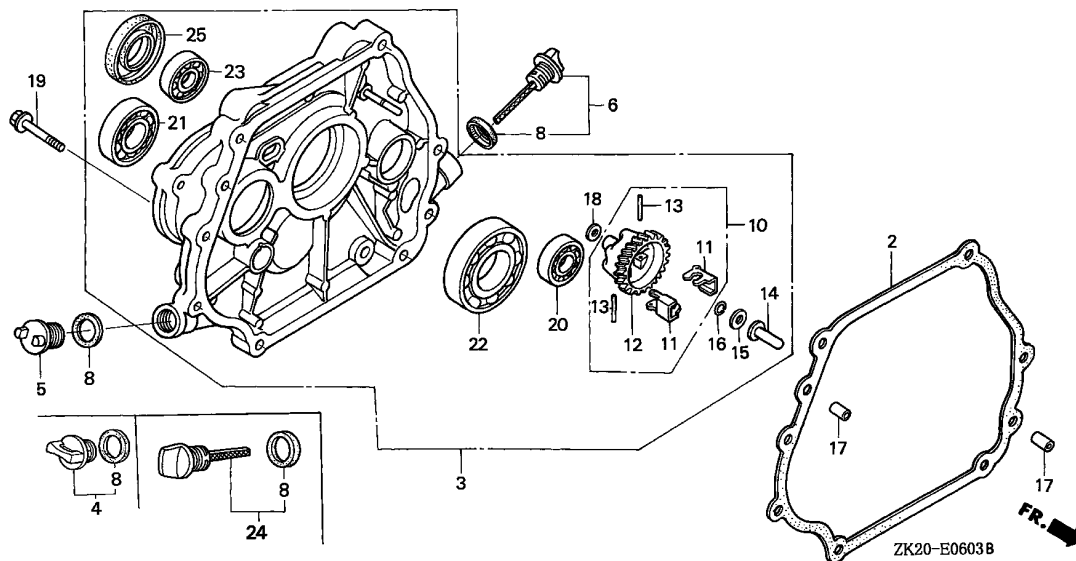

Ref. No.	Part No.	Description	Reqd. QTY			Serial No.	Parts catalogue code
			(1)	(2)	(3)		
4	15600-ZG4-003	CAP ASSY., OIL FILLER	1	1	-	EDN2,EDN2/A,HA2/A,HHQ4,HHQ4/A,HX/A,HXQ4,HXQ4/A,LDB1,LDB3,LH/A,LHE4,LHE4/A,LHZ,LJ/A,LJG,LJG/A,LJG1,LJS,LJS/A,LKS/A,LP/A,LSS4,LSS5,LSS5/A,LSX,LSX/A,LT,LT/A,LX/A,LXF,LXQ4,LXQ4/A,LX2/A,L1/A,PMT2,PMT2/A,QXC9,QXC9/A,SMX2,SMX2/A	
			1	1	-	3210414 LJ,LM9,L1	
			1	-	-	2901133 HAQ,HA2,HH,HX,LD,LH,LHE,LKS,LP,LW,LX,LXZ,LX2	
			1	-	-	3210413 HA	
5	15620-ZG4-910	CAP, OIL FILLER	1	1	-	3210413 LJ,LM9,L1	
			1	-	-	3210414 HA	
			1	-	-	2901132 HAQ,HA2,HH,HX,LD,LH,LHE,LKS,LP,LW,LX,LXZ,LX2	
6	15600-735-700	CAP ASSY., OIL FILLER	1	(1)	-	3210413 LJ,LM9,LNJ,L1	
	15600-735-003		1	-	-	2901132 HA,HAQ,HA2,HH,HX,LD,LH,LHE,LKS,LP,LW,LX,LXZ,LX2	
			1	(1)	-	EDN2,EDN2/A,HA2/A,HHQ4,HHQ4/A,HX/A,HXQ4,HXQ4/A,LDB1,LDB3,LH/A,LHE4,LHE4/A,LHZ,LJ/A,LJG,LJG/A,LJG1,LJS,LJS/A,LKS/A,LP/A,LSS4,LSS5,LSS5/A,LSX,LSX/A,LT,LT/A,LX/A,LXF,LXQ4,LXQ4/A,LX2/A,L1/A,PMT2,PMT2/A,QXC9,QXC9/A,SMX2,SMX2/A	
			1	(1)	-	3210414 LJ,LM9,LNJ,L1	
			1	-	-	2901133 HA,HAQ,HA2,HH,HX,LD,LH,LHE,LKS,LP,LW,LX,LXZ,LX2	
8	15625-ZE1-003	PACKING, OIL FILLER CAP	2	1	-	EDN2,EDN2/A,HA,HAQ,HA2,HA2/A,HH,HHQ4,HHQ4/A,HX/A,HXQ4,HXQ4/A,LD,LDB1,LDB3,LH,LH/A,LHE,LHE4,LHE4/A,LHZ,LJ/A,LJG,LJG/A,LJG1,LJS,LJS/A,LKS,LKS/A,LM9,LNJ,LNZ,LP,LP/A,LSS4,LSS5,LSS5/A,LSX,LSX/A,LT,LT/A,LW,LX,LX/A,LXF,LXQ4,LXQ4/A,LXZ,LX2,LX2/A,L1,L1/A,PMT2,PMT2/A,QXC9,QXC9/A,SMX2,SMX2/A	
			2	(1)	-	LXF,L1,L1/A	

2

Ref. No.	Part No.	Description	Reqd. QTY			Serial No.	Parts catalogue code
			(1)	(2)	(3)		
10	16510-ZE2-000	GOVERNOR ASSY.	1	1	-	EDN2,EDN2/A,HH,HHQ4,HHQ4/A,HX,HX/A,HXQ4,HXQ4/A,LD,LDB1,LDB3,LH,LH/A,LHE,LHE4,LHE4/A,LHZ,LJ,LJ/A,LJG,LJG/A,LJG1,LM9,LNJ,LNZ,LP,LP/A,LSS4,LSS5,LSS5/A,LSX,LSX/A,LT,LT/A,LW,LX,LX/A,LXF,LXQ4,LXQ4/A,LXZ,LX2,LX2/A,L1,L1/A,PMT2,PMT2/A,QXC9,QXC9/A,SMX2,SMX2/A	
	16510-ZE2-811	(1)	-	-	LJS,LJS/A,LKS,LKS/A HA,HAQ,HA2,HA2/A,LJS,LJS/A,LKS,LKS/A	
11	16511-ZE2-000	WEIGHT, GOVERNOR	2	2	-	EDN2,EDN2/A,HA,HAQ,HA2,HA2/A,HH,HHQ4,HHQ4/A,HX,HX/A,HXQ4,HXQ4/A,LD,LDB1,LDB3,LH,LH/A,LHE,LHE4,LHE4/A,LHZ,LJ,LJ/A,LJG,LJG/A,LJG1,LJS,LJS/A,LKS,LKS/A,LM9,LNJ,LNZ,LP,LP/A,LSS4,LSS5,LSS5/A,LSX,LSX/A,LT,LT/A,LW,LX,LX/A,LXF,LXQ4,LXQ4/A,LXZ,LX2,LX2/A,L1,L1/A,PMT2,PMT2/A,QXC9,QXC9/A,SMX2,SMX2/A	
12	16512-ZE2-000	HOLDER, GOVERNOR WEIGHT	1	1	-	EDN2,EDN2/A,HH,HHQ4,HHQ4/A,HX,HX/A,HXQ4,HXQ4/A,LD,LDB1,LDB3,LH,LH/A,LHE,LHE4,LHE4/A,LHZ,LJ,LJ/A,LJG,LJG/A,LJG1,LM9,LNJ,LNZ,LP,LP/A,LSS4,LSS5,LSS5/A,LSX,LSX/A,LT,LT/A,LW,LX,LX/A,LXF,LXQ4,LXQ4/A,LXZ,LX2,LX2/A,L1,L1/A,PMT2,PMT2/A,QXC9,QXC9/A,SMX2,SMX2/A	
	16512-ZE2-811	(1)	-	-	LJS,LJS/A,LKS,LKS/A HA,HAQ,HA2,HA2/A,LJS,LJS/A,LKS,LKS/A	
13	16513-ZE2-000	PIN, GOVERNOR WEIGHT	2	2	-	EDN2,EDN2/A,HA,HAQ,HA2,HA2/A,HH,HHQ4,HHQ4/A,HX,HX/A,HXQ4,HXQ4/A,LD,LDB1,LDB3,LH,LH/A,LHE,LHE4,LHE4/A,LHZ,LJ,LJ/A,LJG,LJG/A,LJG1,LJS,LJS/A,LKS,LKS/A,LM9,LNJ,LNZ,LP,LP/A,LSS4,LSS5,LSS5/A,LSX,LSX/A,LT,LT/A,LW,LX,LX/A,LXF,LXQ4,LXQ4/A,LXZ,LX2,LX2/A,L1,L1/A,PMT2,PMT2/A,QXC9,QXC9/A,SMX2,SMX2/A	
14	16531-ZE2-000	SLIDER, GOVERNOR	1	1	-	4211335 EDN2,HA2,HHQ4,HX,HXQ4,LH,LHE4,LJ,LJG,LJS,LKS,LP,LSS5,LSX,LT,LX,LXQ4,LX2,L1,PMT2,QXC9,SMX2	
	16531-Z0A-000	1	1	-	EDN2/A,HA,HAQ,HA2/A,HH,HHQ4/A,HX/A,HXQ4/A,LD,LDB1,LDB3,LH/A,LHE,LHE4/A,LHZ,LJ/A,LJG/A,LJG1,LJS/A,LKS/A,LM9,LNJ,LNZ,LP/A,LSS4,LSS5/A,LSX/A,LT/A,LW,LX/A,LXF,LXQ4/A,LXZ,LX2/A,L1/A,PMT2/A,QXC9/A,SMX2/A	
			1	1	-	4211336 EDN2,HA2,HHQ4,HX,HXQ4,LH,LHE4,LJ,LJG,LJS,LKS,LP,LSS5,LSX,LT,LX,LXQ4,LX2,L1,PMT2,QXC9,SMX2	
15	90473-147-000	WASHER, 6X16	1	1	-	3191475 LJ,LM9,LNJ,L1	
			1	-	-	HAQ	
			1	-	-	3190534 HA,HH,HX,LD,LH,LHE,LKS,LP,LW,LX,LXZ	
			1	1	-	4211336 EDN2,HA2,HHQ4,HX,HXQ4,LH,LHE4,LJ,LJG,LJS,LKS,LP,LSS5,LSX,LT,LX,LXQ4,LX2,L1,PMT2,QXC9,SMX2	
16	90602-ZE1-000	CLIP, GOVERNOR HOLDER	1	1	-	EDN2,EDN2/A,HA,HAQ,HA2,HA2/A,HH,HHQ4,HHQ4/A,HX,HX/A,HXQ4,HXQ4/A,LD,LDB1,LDB3,LH,LH/A,LHE,LHE4,LHE4/A,LHZ,LJ,LJ/A,LJG,LJG/A,LJG1,LJS,LJS/A,LKS,LKS/A,LM9,LNJ,LNZ,LP,LP/A,LSS4,LSS5,LSS5/A,LSX,LSX/A,LT,LT/A,LW,LX,LX/A,LXF,LXQ4,LXQ4/A,LXZ,LX2,LX2/A,L1,L1/A,PMT2,PMT2/A,QXC9,QXC9/A,SMX2,SMX2/A	
17	90701-HC4-000	DOWEL PIN, 8X12	2	2	-	EDN2,EDN2/A,HA,HAQ,HA2,HA2/A,HH,HHQ4,HHQ4/A,HX,HX/A,HXQ4,HXQ4/A,LD,LDB1,LDB3,LH,LH/A,LHE,LHE4,LHE4/A,LHZ,LJ,LJ/A,LJG,LJG/A,LJG1,LJS,LJS/A,LKS,LKS/A,LM9,LNJ,LNZ,LP,LP/A,LSS4,LSS5,LSS5/A,LSX,LSX/A,LT,LT/A,LW,LX,LX/A,LXF,LXQ4,LXQ4/A,LXZ,LX2,LX2/A,L1,L1/A,PMT2,PMT2/A,QXC9,QXC9/A,SMX2,SMX2/A	
18	94101-06800	WASHER, PLAIN, 6MM	1	1	-	EDN2,EDN2/A,HA,HAQ,HA2,HA2/A,HH,HHQ4,HHQ4/A,HX,HX/A,HXQ4,HXQ4/A,LD,LDB1,LDB3,LH,LH/A,LHE,LHE4,LHE4/A,LHZ,LJ,LJ/A,LJG,LJG/A,LJG1,LJS,LJS/A,LKS,LKS/A,LM9,LNJ,LNZ,LP,LP/A,LSS4,LSS5,LSS5/A,LSX,LSX/A,LT,LT/A,LW,LX,LX/A,LXF,LXQ4,LXQ4/A,LXZ,LX2,LX2/A,L1,L1/A,PMT2,PMT2/A,QXC9,QXC9/A,SMX2,SMX2/A	
19	95701-08035-00	BOLT, FLANGE, 8X35	7	7	-	EDN2,EDN2/A,HA,HAQ,HA2,HA2/A,HH,HHQ4,HHQ4/A,HX,HX/A,HXQ4,HXQ4/A,LD,LDB1,LDB3,LH,LH/A,LHE,LHE4,LHE4/A,LHZ,LJ,LJ/A,LJG,LJG/A,LJG1,LJS,LJS/A,LKS,LKS/A,LM9,LNJ,LNZ,LP,LP/A,LSS4,LSS5,LSS5/A,LSX,LSX/A,LT,LT/A,LW,LX,LX/A,LXF,LXQ4,LXQ4/A,LXZ,LX2,LX2/A,L1,L1/A,PMT2,PMT2/A,QXC9,QXC9/A,SMX2,SMX2/A	
20	96100-62020-00	BEARING, RADIAL BALL, 6202 ..	1	-	-	HA,HAQ,HA2,HA2/A,LJS,LJS/A,LKS,LKS/A	



E-6-3

CRANKCASE COVER(4)

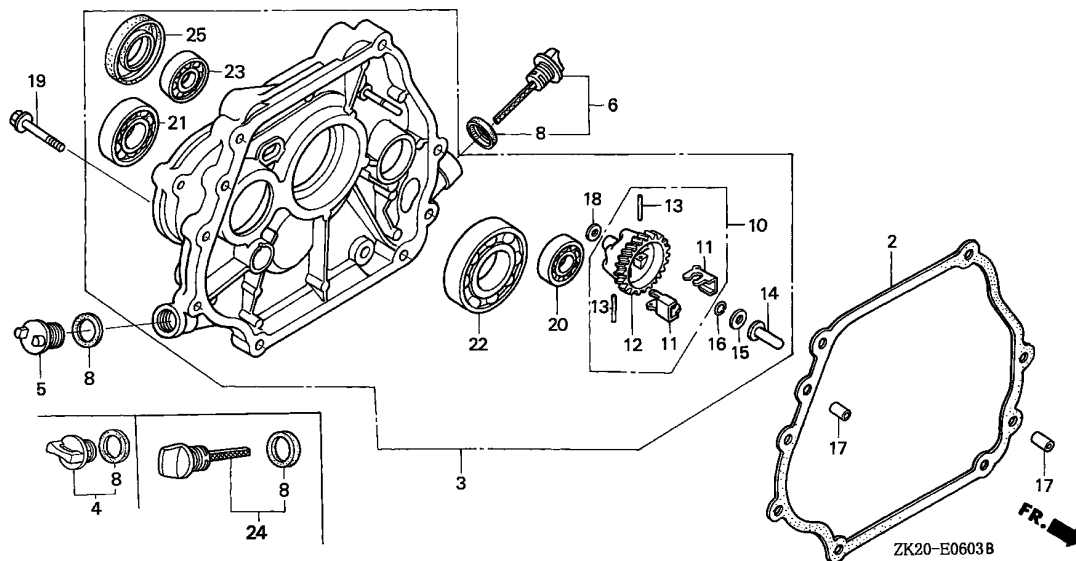

Ref. No.	Part No.	Description	Reqd. QTY			Serial No.	Parts catalogue code
			(1)	(2)	(3)		
			GX240K1				
21	96100-62040-00	BEARING, RADIAL BALL, 6204 ..	1	1	-	-----	HA,HAQ,HA2,HA2/A,HH,HHQ4,HHQ4/A,HX,HX/A,HXQ4,HXQ4/A,LD,LDB1,LDB3 LH,LH/A,LHE,LHE4,LHE4/A,LHZ,LJ,LJ/A,LJG,LJG/A,LJG1,LJS,LJS/A,LKS LKS/A,LM9,LNJ,LNZ,LP,LP/A,LSS4,LSS5,LSS5/A,LSX,LSX/A,LT,LT/A,LW LX,LX/A,LXF,LXQ4,LXQ4/A,LXZ,LX2,LX2/A,L1,L1/A
22	96100-62060-00	BEARING, RADIAL BALL, 6206 ..	1	1	-	-----	EDN2,EDN2/A,HA,HAQ,HA2,HA2/A,HH,HHQ4,HHQ4/A,HX,HX/A,HXQ4,HXQ4/A LD,LDB1,LDB3,LH,LH/A,LHE,LHE4,LHE4/A,LHZ,LJ,LJ/A,LJG,LJG/A,LJG1 LJS,LJS/A,LKS,LKS/A,LM9,LNJ,LNZ,LP,LP/A,LSS4,LSS5,LSS5/A,LSX LSX/A,LT,LT/A,LW,LX,LX/A,LXF,LXQ4,LXQ4/A,LXZ,LX2,LX2/A,L1,L1/A PMT2,PMT2/A,QXC9,QXC9/A,SMX2,SMX2/A
23	96100-63020-00	BEARING, RADIAL BALL, 6302 ..	1	-	-	-----	HA,HAQ,HA2,HA2/A,HH,HHQ4,HHQ4/A,HX,HX/A,HXQ4,HXQ4/A
24	15600-735-003	CAP ASSY., OIL FILLER	1	-	-	-----	LNZ
	15600-735-700	1	-	-	3210414	LNJ
	15600-735-700	1	-	-	3210413	LNJ
25	91201-890-003	OIL SEAL, 30X46X8	1	-	-	-----	EDN2,EDN2/A,PMT2,PMT2/A,QXC9,QXC9/A,SMX2,SMX2/A

E-6-4

CRANKCASE COVER(5)

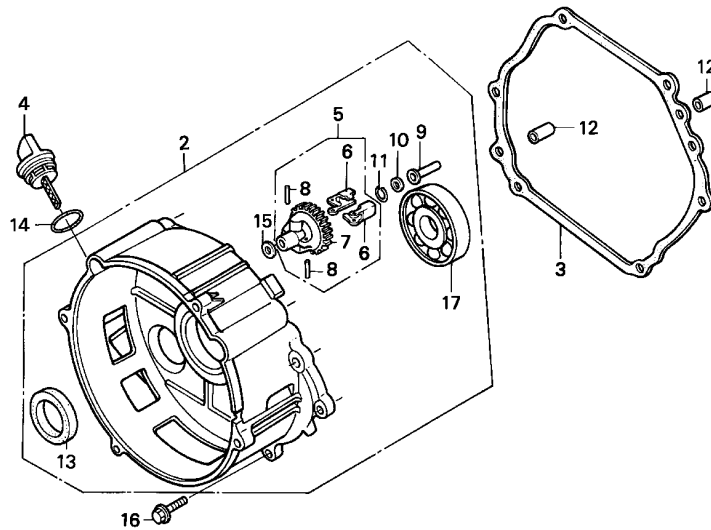

ZK20-E0604A

Ref. No.	L.O.N.	(Relative ref. Number) Description	F.R.T.
2	1101G1	COVER, CRANKCASE(B)	0.3
3	1101F9	PACKING, CRANKCASE COVER(A) ..	0.3
7		(6)	
	1161C8	HOLDER, GOVERNOR WEIGHT (B) ...	0.4
9	1161B6	SLIDER, GOVERNOR	0.3
13	1101G3	OIL SEAL, CRANKCASE COVER	0.4
17	1101A5	BEARING, CRANKSHAFT :LEFT	0.5

Ref. No.	Part No.	Description	Reqd. QTY			Serial No.	Parts catalogue code
			(1)	(2)	(3)		
2	11300-ZE2-700	COVER ASSY., CRANKCASE	1	-	-	ES	
			1	-	-	3618361	ES1
			1	-	-	3634564	VS B1
			1	-	-	4211335	ES3
	11300-ZE2-E70	1	-	-	3618362	4211335 ES1
	11300-ZE2-701	1	-	-	4211336	ES3
	11300-ZE2-E71	1	-	-	4211336	ES1
	11300-ZE2-405	1	-	-		ES1/A,ES2
	11300-ZE2-406	1	-	-		ES3/A
3	11381-ZE2-800	PACKING, CASE COVER	1	-	-	ES	
			1	-	-	3634564	VS B1
			1	-	-	4045100	ES1,ES3
	11381-ZE2-801	1	-	-		ES1/A,ES2,ES3/A
			1	-	-	4045101	ES1,ES3
4	15620-ZE2-700	CAP, OIL FILLER	1	-	-		ES,ES1,ES1/A,ES2,ES3,ES3/A
			1	-	-	3634564	VS B1
5	16510-ZE2-000	GOVERNOR ASSY.	1	-	-		ES,ES1,ES1/A,ES2,ES3,ES3/A
			1	-	-	3634564	VS B1
6	16511-ZE2-000	WEIGHT, GOVERNOR	2	-	-		ES,ES1,ES1/A,ES2,ES3,ES3/A
			2	-	-	3634564	VS B1
7	16512-ZE2-000	HOLDER, GOVERNOR WEIGHT	1	-	-		ES,ES1,ES1/A,ES2,ES3,ES3/A
			1	-	-	3634564	VS B1
8	16513-ZE2-000	PIN, GOVERNOR WEIGHT	2	-	-		ES,ES1,ES1/A,ES2,ES3,ES3/A
			2	-	-	3634564	VS B1
9	16531-ZE2-000	SLIDER, GOVERNOR	1	-	-		ES1,ES3
	16531-Z0A-000	1	-	-		ES,ES1/A,ES2,ES3/A
			1	-	-	4211336	ES1,ES3
			1	-	-	3634564	VS B1



FR.

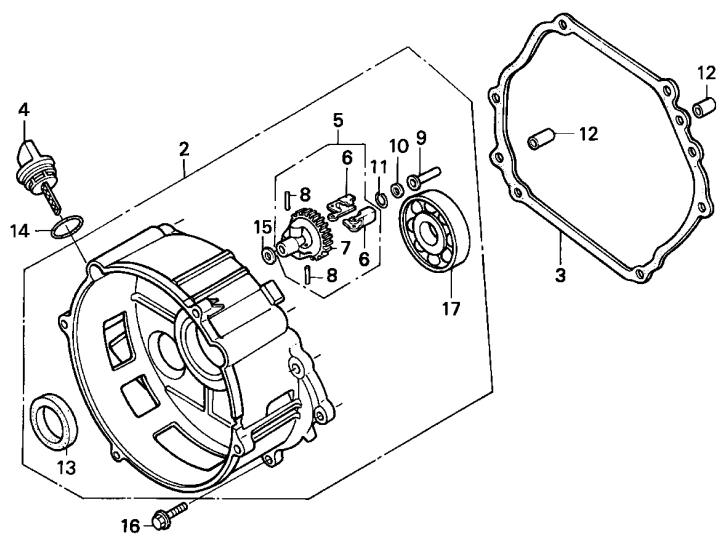

ZK20-E0604A

Ref. No.	Part No.	Description	Reqd. QTY			Serial No.	Parts catalogue code
			(1)	(2)	(3)		
10	90473-147-000	WASHER, 6X16	1	-	-	3190534	ES,ES1,ES3
			1	-	-	4211336	ES1,ES3
11	90602-ZE1-000	CLIP, GOVERNOR HOLDER	1	-	-	ES,ES1,ES1/A,ES2,ES3,ES3/A	
12	90701-HC4-000	DOWEL PIN, 8X12	1	-	-	3634564	VSB1
			2	-	-	3634564	ES,ES1,ES1/A,ES2,ES3,ES3/A
13	91201-890-003	OIL SEAL, 30X46X8	1	-	-	ES,ES1,ES1/A,ES2,ES3,ES3/A	
			1	-	-	3634564	VSB1
14	91301-805-000	O-RING, 26X2.7	1	-	-	ES,ES1,ES1/A,ES2,ES3,ES3/A	
			1	-	-	3634564	VSB1
15	94101-06800	WASHER, PLAIN, 6MM	1	-	-	ES,ES1,ES1/A,ES2,ES3,ES3/A	
			1	-	-	3634564	VSB1
16	95701-08035-00	BOLT, FLANGE, 8X35	7	-	-	ES,ES1,ES1/A,ES2,ES3,ES3/A	
			7	-	-	3634564	VSB1
17	96100-62060-00	BEARING, RADIAL BALL, 6206 ..	1	-	-	ES,ES1,ES1/A,ES2,ES3,ES3/A	
			1	-	-	3634564	VSB1

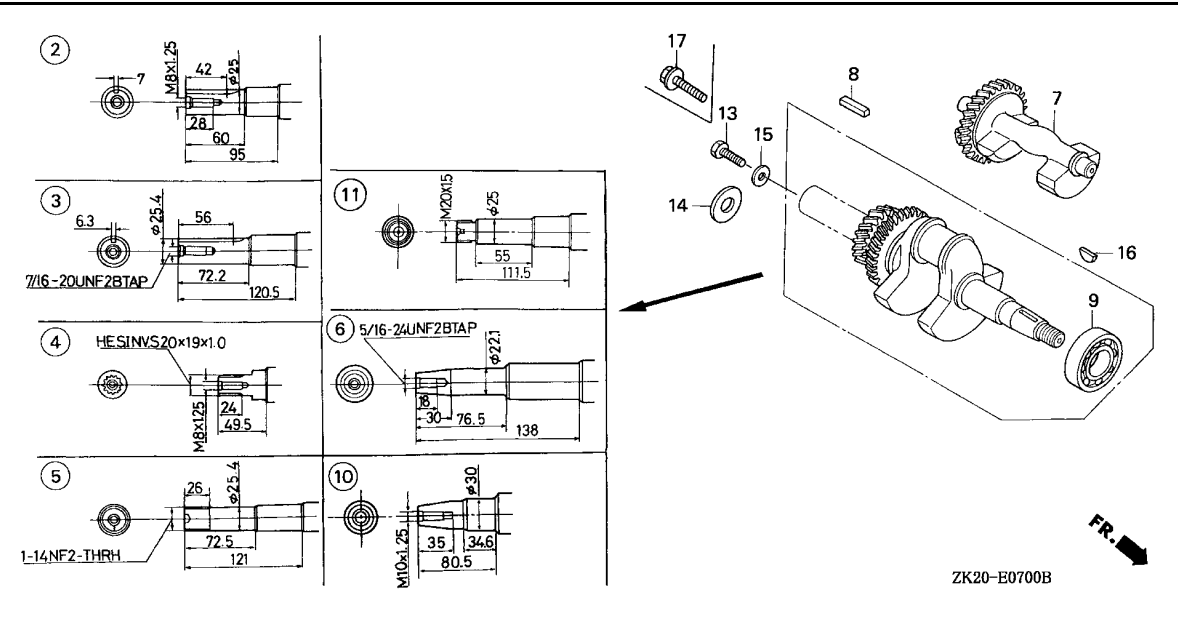

Ref. No.	L.O.N.	(Relative ref. Number) Description	F.R.T.
2		(3,4,5,6,10,11)	
2	1101F0	CRANKSHAFT	1.1
7	1101D8	WEIGHT, BALANCER	0.3
9	1101A4	BEARING, CRANKSHAFT :FRONT ...	1.3

Ref. No.	Part No.	Description	Reqd. QTY			Serial No.	Parts catalogue code
			(1)	(2)	(3)		
2	13310-ZE2-010	CRANKSHAFT COMP.	1	1	-	RD, RH, RHE, RHE4, RHQ4, RJ, RSS1, RX, RXQ4, R1, SD, SDB1, SDB3, SE, SH, SHE, SHEZ, SHW, SJ, SJC, SJC1, SJC5, SJG, SJP, SMS, SMX2, SNC1, SNE1, SNR, STP, STQ, SW, SWE, SX, SXB, SXE, SXEB, SXE4, SXQ4, SXU, S1	
			1	1	-	4769737 RD/A, RHQ4/A, RJ/A, RSS1/A, RX/A, RXQ4/A, R1/A, SD/A, SDB3/A, SE/A, SHW/A, SJ/A, SJC1/A, SJC5/A, SJG/A, SMS/A, SMX2/A, SNR/A, STP/A, STQ/A, SX/A, SXE4/A, SXQ4/A, SXU/A, S1/A	
	13320-ZE2-010	1	-	-	RA, RA2, RSC2, RTB2, SK	
	13310-ZE2-020	1	1	-	4767677 RA2/A, RTB2/A	
	13310-ZE2-020	1	1	-	4769738 RD/A, RHQ4/A, RJ/A, RSS1/A, RX/A, RXQ4/A, R1/A, SD/A, SDB3/A, SE/A, SHW/A, SJ/A, SJC1/A, SJC5/A, SJG/A, SMS/A, SMX2/A, SNR/A, STP/A, STQ/A, SX/A, SXE4/A, SXQ4/A, SXU/A, S1/A	
	13320-ZE2-020	1	-	-	4767678 RA2/A, RTB2/A	
3	13310-ZE2-601	CRANKSHAFT COMP.	1	1	-	QAG, QD, QDA, QE, QH, QHC, QHE, QHP1, QHQ4, QHZ, QMH, QMX2, QP, QT, QTC2, QX, QXB, QXC, QXC9, QXE, QXEB, QXE4, QXQ4, QXU, Q1	
			1	1	-	4772141 QAG/A, QD/A, QE/A, QH/A, QHB2, QHP1/A, QHQ4/A, QMH/A, QP/A, QT/A, QTC2/A, QX/A, QXC/A, QXC9/A, QXE/A, QXE4/A, QXQ4/A, QXU/A, Q1/A	
	13310-ZK2-600	1	-	-	QXB7, QXB7/A	
	13320-ZE2-601	1	-	-	QA, QAB2, QAE, QAE2, QAG2, QAQ, QAQ4, QAR2, QA2, QC12, QKA2	
			1	-	-	4773331 QAB2/A, QAE2/A, QAG2/A, QAR2/A, QA2/A, QC12/A, QW24	
	13310-ZE2-602	1	1	-	4772142 QAG/A, QD/A, QE/A, QH/A, QHB2, QHP1/A, QHQ4/A, QMH/A, QP/A, QT/A, QTC2/A, QX/A, QXC/A, QXC9/A, QXE/A, QXE4/A, QXQ4/A, QXU/A, Q1/A	
	13320-ZE2-602	1	-	-	4773332 QAB2/A, QAE2/A, QAG2/A, QAR2/A, QA2/A, QC12/A, QW24	
4	13310-ZE2-611	CRANKSHAFT COMP.	1	1	-	HH, HHQ4, HTX, HX, HXQ4, LD, LDB1, LDB3, LH, LHE, LHE4, LHZ, LJ, LJG, LJG1, LM9, LNJ, LNZ, LP, LSS4, LSS5, LSX, LT, LW, LX, LXQ4, LXZ, LX2, L1	
			1	1	-	4769508 HHQ4/A, HX/A, HXQ4/A, LH/A, LHE4/A, LJ/A, LJG/A, LP/A, LSS5/A, LSX/A, LT/A, LX/A, LXF, LXQ4/A, LX2/A, L1/A	
	13320-ZE2-611	1	-	-	HA, HAQ, HA2, LJS, LKS	
	13310-ZE2-612	1	1	-	4769509 HHQ4/A, HX/A, HXQ4/A, LH/A, LHE4/A, LJ/A, LJG/A, LP/A, LSS5/A, LSX/A, LT/A, LX/A, LXF, LXQ4/A, LX2/A, L1/A	



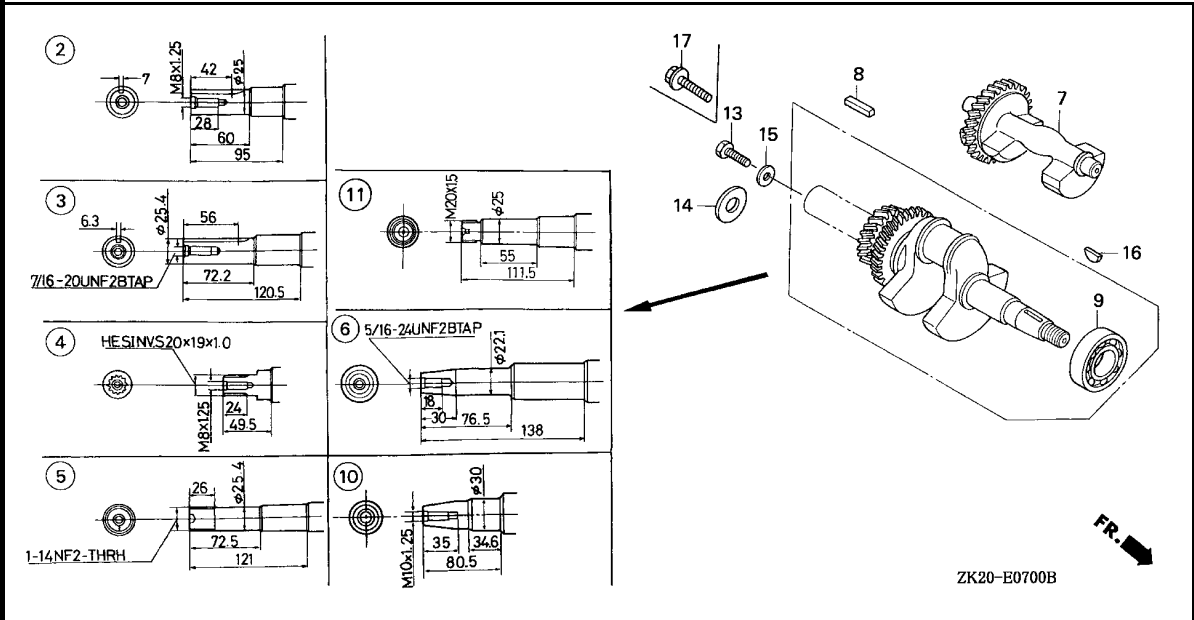

Ref. No.	Part No.	Description	Reqd. QTY			Serial No.	Parts catalogue code
			(1)	(2)	(3)		
(4)	13320-ZE2-612	CRANKSHAFT COMP.	1	-	-	HA2/A,LJS/A,LKS/A	
5	13310-ZE2-651	CRANKSHAFT COMP.	1	1	-	PMT2,PX,P1	
	13320-ZE2-651	1	-	-	4773271 PMT2/A,PX/A	
	13310-ZE2-652	1	-	-	PA,PAE,PA2	
	13320-ZE2-652	1	-	-	4773272 PMT2/A,PX/A	
	13320-ZE2-652	1	-	-	PA2/A	
6	13310-ZE2-671	CRANKSHAFT COMP.	1	1	-	VDG2,VH,VMX,VNG,VSB1,VX,VXB,VXE,VXEB,VXQ4,VXU,VXU1,V1	
			1	-	-	4672341 VDG2/A,VH/A,VSB1/A,VS3,VX/A,VXB/A,VXE/A,VXEB/A,VXQ4/A,VXU/A	
			-	-	1	VXU1/A	
	13310-ZK2-670	1	-	-	VXB7,VXB7/A,VXQ7,VXQ7/A	
	13320-ZE2-671	1	-	-	VA,VAH1,VA2,VA2/A,VH12,VH12/A,VMT2,VTA,VTA2,VTA2/A,VWC2,VWC2/A	
	13310-ZE2-672	1	-	-	VS4	
			1	-	-	4672342 VDG2/A,VH/A,VSB1/A,VS3,VX/A,VXB/A,VXE/A,VXEB/A,VXQ4/A,VXU/A	
			1	-	-	VXU1/A	
7	13351-ZE2-010	WEIGHT, BALANCER	1	-	-	HA,HAQ,HA2,HA2/A,LJS,LJS/A,LK,LKS,LKS/A,PA,PAE,PA2,PA2/A,QA,QAB2	
						QAB2/A,QAQ,QAQ2,QAQ2/A,QAQ2,QAQ2/A,QAQ,QAQ4,QAQ4/A,QA2,QA2/A	
						QC12,QC12/A,QKA2,QW24,RA,RA2,RA2/A,RSC2,RTB2,RTB2/A,SK,VA,VAH1	
						VA2,VA2/A,VH12,VH12/A,VMT2,VTA,VTA2,VTA2/A,VWC2,VWC2/A	
8	90741-805-000	KEY, 7X7X33	1	(1)	-	SD,SD/A,SDB1,SDB3,SDB3/A,SE,SE/A,SH,SHE,SHEZ,SHW,SHW/A,SJ,SJ/A	
						SJC,SJC1,SJC1/A,SJC5,SJC5/A,SJG,SJG/A,SJP,SK,SMS,SMS/A,SMX2	
						SMX2/A,SNR,SNR/A,STP,STP/A,STQ,STQ/A,SW,SWE,SX,SX/A,SXB,SXE,SXEB	
						SXE4,SXE4/A,SXQ4,SXQ4/A,SXU,SXU/A,S1,S1/A	
	90741-889-810	KEY, 7X7X33(YELLOW)	(1)	(1)	-	ED3,ED4,ED4/A,ED5,ED5/A,EN,ET,ETS,ETX,SD,SD/A,SDB1,SDB3,SDB3/A,SE	
						SE/A,SH,SHE,SHEZ,SHW,SHW/A,SJ,SJ/A,SJC,SJC1,SJC1/A,SJC5,SJC5/A	
						SJG,SJG/A,SJP,SK,SMS,SMS/A,SMX2,SMX2/A,SNC1,SNE1,SNR,SNR/A,STP	
						STP/A,STQ,STQ/A,SW,SWE,SX,SX/A,SXB,SXE,SXEB,SXE4,SXE4/A,SXQ4	
						SXQ4/A,SXU,SXU/A,S1,S1/A	

Ref. No.	Part No.	Description	Reqd. QTY			Serial No.	Parts catalogue code
			(1)	(2)	(3)		
(8)	90745-ZE2-600	KEY, 6.3X6.3X43	1	(1)	-	-----	QA,QAB2,QAB2/A,QAE,QAE2,QAE2/A,QAG,QAG/A,QAG2,QAG2/A,QAQ,QAQ4,QAR2,QAR2/A,QA2,QA2/A,QC12,QC12/A,QD,QD/A,QDA,QE,QE/A,QH,QH/A,QHB2,QHC,QHE,QHP1,QHP1/A,QHQ4,QHQ4/A,QHZ,QKA2,QMH,QMH/A,QMX2,QP,QP/A,QT,QT/A,QW24,QX,QX/A,QXB,QXB7,QXB7/A,QXC,QXC/A,QXC9,QXC9/A,QXE,QXE/A,QXEB,QXE4,QXE4/A,QXQ4,QXQ4/A,QXU,QXU/A,Q1,Q1/A
9	96100-62060-00	BEARING, RADIAL BALL, 6206 ..	1	1	1		
10	13310-ZE2-701	CRANKSHAFT COMP.	1	-	-	-----	EDN,EDN2,EDS,EDS1,EDS2,EDS3,EDS5,EDS6,EDT1,EDT2,EDT6,ED2,ED3,ED4,ED5,EN,EN2,ES,ES1,ES3,ET,ETS,ETX,VTE2
			1	-	-	4766115	EDN2/A,EDS1/A,EDS2/A,EDS6/A,EDT1/A,EDT6/A,ED2/A,ED4/A,ED5/A,EN2/A,ES1/A,ES3/A
	13310-ZE2-702	1	-	-	-----	EDT3,ES2
			1	-	-	4766116	EDN2/A,EDS1/A,EDS2/A,EDS6/A,EDT1/A,EDT6/A,ED2/A,ED4/A,ED5/A,EN2/A,ES1/A,ES3/A
11	13310-ZE2-631	CRANKSHAFT COMP.	1	1	-	-----	WH,WJ,WKA,WKD6,WKT2,WKT4,W1
			1	1	-	4769884	WJ/A,WKD6/A,WKT2/A,WKT4/A,W1/A
	13310-ZE2-632	1	1	-	4769885	WJ/A,WKD6/A,WKT2/A,WKT4/A,W1/A
			1	-	-	-----	WMK
13	90003-ZE2-000	BOLT, HEX. (7/16-20UNF)	1	(1)	-	-----	QMX2,Q1,Q1/A
	92000-08025-0A	BOLT, HEX., 8X25	-	(1)	-	4847898	S1/A
	92101-08025-0A	1	(1)	-	-----	SJ,SJ/A,SJC,SJC1,SJC1/A,SJC5,SJC5/A,SJG,SJG/A,SJP,SK,SMS,SMS/A,SMX2,SMX2/A,SNR,SNR/A,STP,STP/A,STQ,STQ/A,S1
			-	(1)	-	4847899	S1/A
14	90473-ZE2-000	WASHER, 11.7MM	1	(1)	-	-----	QMX2,Q1,Q1/A
15	90534-706-010	WASHER, LOCK, 8MM	1	(1)	-	-----	EN,ET,ETS,ETX,SJ,SJ/A,SJC,SJC1,SJC1/A,SJC5,SJC5/A,SJG,SJG/A,SJP,SK,SMS,SMS/A,SMX2,SMX2/A,SNR,SNR/A,STP,STP/A,STQ,STQ/A,S1,S1/A
16	13331-357-000	KEY, SPECIAL WOODRUFF, 25X18	1	1	-	-----	LJ,LK,LNJ,RJ,SJ,SJP,SK,STP,STQ,S1,WJ,WKA
	90741-ZE2-000	1	1	-	-----	EDN,EDN2,EDN2/A,EDS,EDS1,EDS1/A,EDS2,EDS2/A,EDS3,EDS5,EDS6,EDS6/A,EDT1,EDT1/A,EDT2,EDT3,EDT6,EDT6/A,ED2,ED2/A,ED3,ED4,ED4/A,ED5,ED5/A,EN,EN2,EN2/A,ES,ES1,ES1/A,ES2,ES3,ES3/A,ET,ETS,ETX,HA,HAQ,HA2,HA2/A,HH,HHQ4,HHQ4/A,HTX,HX,HX/A,HXQ4,HXQ4/A,LD,LDB1,LDB3,LH,LH/A,LHE,LHE4,LHE4/A,LHZ,LJ,LJ/A,LJG,LJG/A,LJG1,LJS,LJS/A,LKS,LKS/A,LM9,LNZ,LP,LP/A,LSS4,LSS5,LSS5/A,LXS,LXS/A,LT,LT/A,LW,LX,LX/A,LXF,LXQ4,LXQ4/A,LXZ,LX2,LX2/A,L1,L1/A,PA,PAE,PA2,PA2/A,PMT2,PMT2/A,PX,PX/A,P1,QA,QAB2,QAB2/A,QAE,QAE2,QAE2/A,QAG,QAG/A,QAG2,QAG2/A,QAQ,QAQ4,QAR2,QAR2/A,QA2,QA2/A,QC12,QC12/A,QD,QD/A,QDA,QE,QE/A,QH,QH/A,QHB2,QHC,QHE,QHP1,QHP1/A,QHQ4,QHQ4/A,QHZ,QKA2,QMH,QMH/A,QMX2,QP,QP/A,QT,QT/A,QTC2,QTC2/A,QW24,QX,QX/A,QXB,QXB7,QXB7/A,QXC,QXC/A,QXC9,QXC9/A,QXE,QXE/A,QXEB,QXE4/A,QXQ4,QXQ4/A,QXU,QXU/A,Q1,Q1/A,RA,RA2,RA2/A,RD,RD/A,RH,RHE,RHE4,RHQ4,RHQ4/A,RJ/A,RSC2,RSS1,RSS1/A,RTB2,RTB2/A,RX,RX/A,RXQ4,RXQ4/A,R1,R1/A,SD,SD/A,SDB1,SDB3,SDB3/A,SE,SE/A,SH,SHE,SHEZ,SHW,SHW/A,SJ/A,SJC,SJC1,SJC1/A,SJC5,SJC5/A,SJG,SJG/A,SMS,SMS/A,SMX2,SMX2/A,SNC1,SNE1,SNR,SNR/A,STP/A,STQ/A,SW,SWE,SX,SX/A,SXB,SXE,SXEB,SXE4,SXE4/A,SXQ4,SXQ4/A,SXU,SXU/A,S1/A,VA,VAH1,VA2,VA2/A,VDG2,VDG2/A,VH,VH/A,VH12,VH12/A,VMT2,VMX,VNG,VSB1,VSB1/A,VS3,VS4,VTA,VTA2,VTA2/A,VTE2,VWC2,VWC2/A,VX,VX/A,VXB,VXB/A,VXB7,VXB7/A,VXE,VXE/A,VXEB,VXEB/A,VXQ4,VXQ4/A,VXQ7,VXQ7/A,VXU,VXU/A,VXU1,VXU1/A,V1,WH,WJ/A,WKD6,WKD6/A,WKT2,WKT2/A,WKT4,WKT4/A,WMK,W1,W1/A
			-	-	1		
17	95701-08025-00	BOLT, FLANGE, 8X25	1	-	-	-----	QAQ4,QHZ



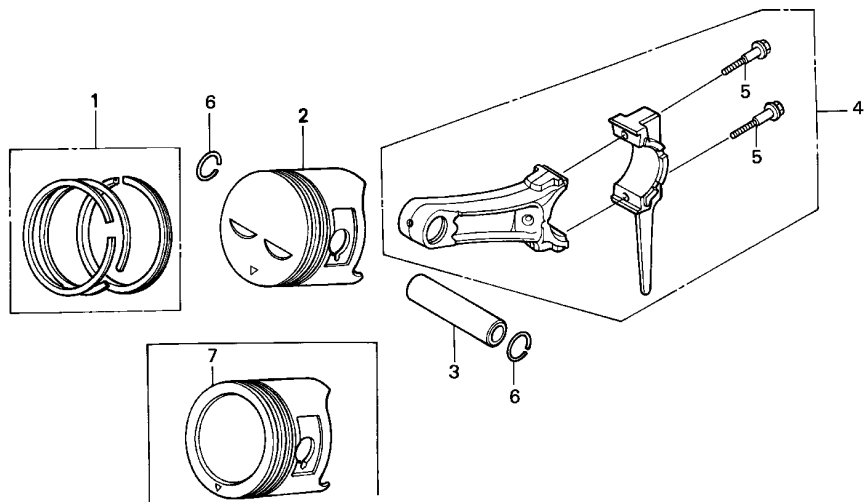

ZK20-E0800A

Ref. No.	L.O.N.	(Relative ref. Number) Description	F.R.T.
2	1111R1	(1,3,4,7) PISTON AND/OR RING SET AND/OR BEARING AND/OR ROD INCLUDES: Inspection/ Measurement/Cleaning	1.2

Ref. No.	Part No.	Description	Reqd. QTY			Serial No.	Parts catalogue code
			(1)	(2)	(3)		
1	13010-ZE2-013	RING SET, PISTON (STD.) (NIPPON)	1	1	1	-----	EDN,EDS,EDS3,EDS5,EDT2,ED3,EN,ES,ET,ETS,ETX,HA,HAQ,HH,HTX,LD,LDB1,LDB3,LHE,LHZ,LJG1,LK,LM9,LNJ,LSS4,LW,LXZ,PA,PAE,P1,QA,QAE,QAQ,QAQ4,QDA,QHC,QHE,QHZ,QKA2,QMX2,QXB,QXEB,RA,RH,RHE,RHE4,SDB1,SH,SHE,SHEZ,SJC,SJP,SK,SNC1,SNE1,SW,SWE,SXB,SXE,SXEB,VA,VAH1,VNG,VTA,VTE2,VXP,VXQP,V1,WH,WKA
			1	1	-	4081304	EDN2,EDS1,EDS2,EDT1,ED2,ED4,ED5,ES1,ES3,HA2,HHQ4,HX,HXQ4,LH,LHE4,LJ,LJG,LKS,LNZ,LP,LSS5,LSX,LT,LX,LXQ4,LX2,L1,PA2,PMT2,PX,QAB2,QAE2,QAG2,QAR2,QA2,QC12,QD,QE,QH,QHP1,QHQ4,QMH,QP,QT,QTC2,QX,QXC,QXC9,QXE,QXE4,QXQ4,QXU,Q1,RA2,RD,RHQ4,RJ,RSC2,RSS1,RTB2,RX,RXQ4,R1,SD,SDB3,SE,SJ,SJC1,SJC5,SJG,SMS,SMX2,SNR,STP,STQ,SX,SXE4,SXQ4,SXU,S1,VA2,VDG2,VH,VH12,VMX,VSB1,VTA2,VWC2,VX,VXB,VXE,VXEB,VXQ4,VXU,VXU1,WJ,WKT2,WKT4,W1
	13010-ZE2-014	RING SET, PISTON (STD.) (TEIKOKU)	1	1	1	-----	EDN,EDS,EDS3,EDS5,EDT2,ED3,EN,ES,ET,ETS,ETX,HA,HAQ,HH,HTX,LD,LDB1,LDB3,LHE,LHZ,LJG1,LK,LM9,LNJ,LSS4,LW,LXZ,PA,PAE,P1,QA,QAE,QAQ,QAQ4,QDA,QHC,QHE,QHZ,QKA2,QMX2,QXB,QXEB,RA,RH,RHE,RHE4,SDB1,SH,SHE,SHEZ,SJC,SJP,SK,SNC1,SNE1,SW,SWE,SXB,SXE,SXEB,VA,VAH1,VNG,VTA,VTE2,VXP,VXQP,V1,WH,WKA
			1	1	-	4081304	EDN2,EDS1,EDS2,EDT1,ED2,ED4,ED5,ES1,ES3,HA2,HHQ4,HX,HXQ4,LH,LHE4,LJ,LJG,LKS,LNZ,LP,LSS5,LSX,LT,LX,LXQ4,LX2,L1,PA2,PMT2,PX,QAB2,QAE2,QAG2,QAR2,QA2,QC12,QD,QE,QH,QHP1,QHQ4,QMH,QP,QT,QTC2,QX,QXC,QXC9,QXE,QXE4,QXQ4,QXU,Q1,RA2,RD,RHQ4,RJ,RSC2,RSS1,RTB2,RX,RXQ4,R1,SD,SDB3,SE,SJ,SJC1,SJC5,SJG,SMS,SMX2,SNR,STP,STQ,SX,SXE4,SXQ4,SXU,S1,VA2,VDG2,VH,VH12,VMX,VSB1,VTA2,VWC2,VX,VXB,VXE,VXEB,VXQ4,VXU,VXU1,WJ,WKT2,WKT4,W1

Ref. No.	Part No.	Description	Reqd. QTY			Serial No.	Parts catalogue code
			(1)	(2)	(3)		
(1)	13011-ZE2-013	RING SET, PISTON (0.25) (NIPPON)	(1)	(1)	(1)	-----	EDN,EDS,EDS3,EDS5,EDT2,ED3,EN,ES,ET,ETS,ETX,HA,HAQ,HH,HTX,LD,LDB1 LDB3,LHE,LHZ,LJG1,LK,LM9,LNJ,LSS4,LW,LXZ,PA,PAE,P1,QA,QAE,QAQ QAQ4,QDA,QHC,QHE,QHZ,QKA2,QMX2,QXB,QXEB,RA,RH,RHE,RHE4,SDB1,SH SHE,SHEZ,SJC,SJP,SK,SNC1,SNE1,SW,SWE,SXB,SXE,SXEB,VA,VAH1,VNG,VTA VTE2,VXP,VXQP,V1,WH,WKA
			(1)	(1)	-	-----	4081304 EDN2,EDS1,EDS2,EDT1,ED2,ED4,ED5,ES1,ES3,HA2,HHQ4,HX,HXQ4,LH,LHE4 LJ,LJG,LKS,LNZ,LP,LSS5,LSX,LT,LX,LXQ4,LX2,L1,PA2,PMT2,PX,QAB2 QAE2,QAG2,QAR2,QA2,QC12,QD,QE,QH,QHP1,QHQ4,QMH,QP,QT,QT2,QX,QXC QXC9,QXE,QXE4,QXQ4,QXU,Q1,RA2,RD,RHQ4,RJ,RSC2,RSS1,RTB2,RX,RXQ4 R1,SD,SDB3,SE,SJ,SJC1,SJC5,SJG,SMS,SMX2,SNR,STP,STQ,STQ,SX,SXE4,SXQ4 SXU,S1,VA2,VDG2,VH,VH12,VMX,VS1,VTA2,VWC2,VX,VXB,VXE,VXEB,VXQ4 VXU,VXU1,WJ,WKT2,WKT4,W1
	13011-ZE2-014	RING SET, PISTON (0.25) (TEIKOKU)	(1)	(1)	(1)	-----	EDN,EDS,EDS3,EDS5,EDT2,ED3,EN,ES,ET,ETS,ETX,HA,HAQ,HH,HTX,LD,LDB1 LDB3,LHE,LHZ,LJG1,LK,LM9,LNJ,LSS4,LW,LXZ,PA,PAE,P1,QA,QAE,QAQ QAQ4,QDA,QHC,QHE,QHZ,QKA2,QMX2,QXB,QXEB,RA,RH,RHE,RHE4,SDB1,SH SHE,SHEZ,SJC,SJP,SK,SNC1,SNE1,SW,SWE,SXB,SXE,SXEB,VA,VAH1,VNG,VTA VTE2,VXP,VXQP,V1,WH,WKA
			(1)	(1)	-	-----	4081304 EDN2,EDS1,EDS2,EDT1,ED2,ED4,ED5,ES1,ES3,HA2,HHQ4,HX,HXQ4,LH,LHE4 LJ,LJG,LKS,LNZ,LP,LSS5,LSX,LT,LX,LXQ4,LX2,L1,PA2,PMT2,PX,QAB2 QAE2,QAG2,QAR2,QA2,QC12,QD,QE,QH,QHP1,QHQ4,QMH,QP,QT,QT2,QX,QXC QXC9,QXE,QXE4,QXQ4,QXU,Q1,RA2,RD,RHQ4,RJ,RSC2,RSS1,RTB2,RX,RXQ4 R1,SD,SDB3,SE,SJ,SJC1,SJC5,SJG,SMS,SMX2,SNR,STP,STQ,SX,SXE4,SXQ4 SXU,S1,VA2,VDG2,VH,VH12,VMX,VS1,VTA2,VWC2,VX,VXB,VXE,VXEB,VXQ4 VXU,VXU1,WJ,WKT2,WKT4,W1
	13012-ZE2-013	RING SET, PISTON (0.50) (NIPPON)	(1)	(1)	(1)	-----	EDN,EDS,EDS3,EDS5,EDT2,ED3,EN,ES,ET,ETS,ETX,HA,HAQ,HH,HTX,LD,LDB1 LDB3,LHE,LHZ,LJG1,LK,LM9,LNJ,LSS4,LW,LXZ,PA,PAE,P1,QA,QAE,QAQ QAQ4,QDA,QHC,QHE,QHZ,QKA2,QMX2,QXB,QXEB,RA,RH,RHE,RHE4,SDB1,SH SHE,SHEZ,SJC,SJP,SK,SNC1,SNE1,SW,SWE,SXB,SXE,SXEB,VA,VAH1,VNG,VTA VTE2,VXP,VXQP,V1,WH,WKA
			(1)	(1)	-	-----	4081304 EDN2,EDS1,EDS2,EDT1,ED2,ED4,ED5,ES1,ES3,HA2,HHQ4,HX,HXQ4,LH,LHE4 LJ,LJG,LKS,LNZ,LP,LSS5,LSX,LT,LX,LXQ4,LX2,L1,PA2,PMT2,PX,QAB2 QAE2,QAG2,QAR2,QA2,QC12,QD,QE,QH,QHP1,QHQ4,QMH,QP,QT,QT2,QX,QXC QXC9,QXE,QXE4,QXQ4,QXU,Q1,RA2,RD,RHQ4,RJ,RSC2,RSS1,RTB2,RX,RXQ4 R1,SD,SDB3,SE,SJ,SJC1,SJC5,SJG,SMS,SMX2,SNR,STP,STQ,SX,SXE4,SXQ4 SXU,S1,VA2,VDG2,VH,VH12,VMX,VS1,VTA2,VWC2,VX,VXB,VXE,VXEB,VXQ4 VXU,VXU1,WJ,WKT2,WKT4,W1
	13012-ZE2-014	RING SET, PISTON (0.50) (TEIKOKU)	(1)	(1)	(1)	-----	EDN,EDS,EDS3,EDS5,EDT2,ED3,EN,ES,ET,ETS,ETX,HA,HAQ,HH,HTX,LD,LDB1 LDB3,LHE,LHZ,LJG1,LK,LM9,LNJ,LSS4,LW,LXZ,PA,PAE,P1,QA,QAE,QAQ QAQ4,QDA,QHC,QHE,QHZ,QKA2,QMX2,QXB,QXEB,RA,RH,RHE,RHE4,SDB1,SH SHE,SHEZ,SJC,SJP,SK,SNC1,SNE1,SW,SWE,SXB,SXE,SXEB,VA,VAH1,VNG,VTA VTE2,VXP,VXQP,V1,WH,WKA
			(1)	(1)	-	-----	4081304 EDN2,EDS1,EDS2,EDT1,ED2,ED4,ED5,ES1,ES3,HA2,HHQ4,HX,HXQ4,LH,LHE4 LJ,LJG,LKS,LNZ,LP,LSS5,LSX,LT,LX,LXQ4,LX2,L1,PA2,PMT2,PX,QAB2 QAE2,QAG2,QAR2,QA2,QC12,QD,QE,QH,QHP1,QHQ4,QMH,QP,QT,QT2,QX,QXC QXC9,QXE,QXE4,QXQ4,QXU,Q1,RA2,RD,RHQ4,RJ,RSC2,RSS1,RTB2,RX,RXQ4 R1,SD,SDB3,SE,SJ,SJC1,SJC5,SJG,SMS,SMX2,SNR,STP,STQ,SX,SXE4,SXQ4 SXU,S1,VA2,VDG2,VH,VH12,VMX,VS1,VTA2,VWC2,VX,VXB,VXE,VXEB,VXQ4 VXU,VXU1,WJ,WKT2,WKT4,W1

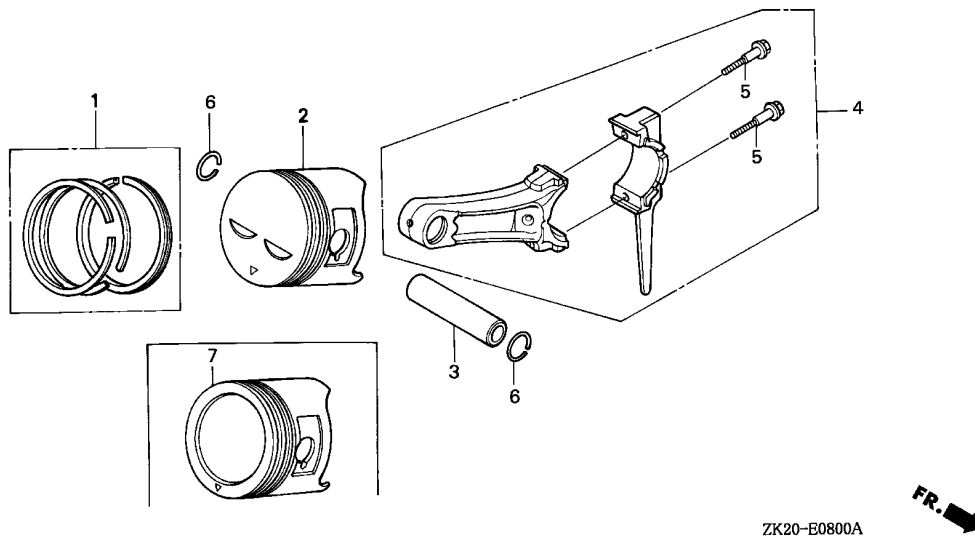

ZK20-E0800A

Ref. No.	Part No.	Description	Reqd. QTY			Serial No.	Parts catalogue code
			GX240K1				
			(1)	(2)	(3)		
(1)	13013-ZE2-013	RING SET, PISTON (0.75) (NIPPON)	(1)	(1)	(1)	-----	EDN,EDS,EDS3,EDS5,EDT2,ED3,EN,ES,ET,ETS,ETX,HA,HAQ,HH,HTX,LD,LDB1,LDB3,LHE,LHZ,LJG1,LK,LM9,LNJ,LSS4,LW,LXZ,PA,PAE,P1,QA,QAE,QAQ,QAQ4,QDA,QHC,QHE,QHZ,QKA2,QMX2,QXB,QXEB,RA,RH,RHE,RHE4,SDB1,SH,SHE,SHEZ,SJC,SJP,SK,SNC1,SNE1,SW,SWE,SXB,SXE,SXEB,VA,VAH1,VNG,VTA,VTE2,VXP,VXQP,V1,WH,WKA
			(1)	(1)	-	4081304	EDN2,EDS1,EDS2,EDT1,ED2,ED4,ED5,ES1,ES3,HA2,HHQ4,HX,HXQ4,LH,LHE4,LJ,LJG,LKS,LNZ,LP,LSS5,LSX,LT,LX,LXQ4,LX2,L1,PA2,PMT2,PX,QAB2,QAE2,QAG2,QAR2,QA2,QC12,QD,QE,QH,QHP1,QHQ4,QMH,QP,QT,QTC2,QX,QXC,QXC9,QXE,QXE4,QXQ4,QXU,Q1,RA2,RD,RHQ4,RJ,RSC2,RSS1,RTB2,RX,RXQ4,R1,SD,SDB3,SE,SJ,SJC1,SJC5,SJG,SMS,SMX2,SNR,STP,STQ,SX,SXE4,SXQ4,SXU,S1,VA2,VDG2,VH,VH12,VMX,VSB1,VTA2,VWC2,VX,VXB,VXE,VXEB,VXQ4,VXU,VXU1,WJ,WKT2,WKT4,W1
	13013-ZE2-014	RING SET, PISTON (0.75) (TEIKOKU)	(1)	(1)	(1)	-----	EDN,EDS,EDS3,EDS5,EDT2,ED3,EN,ES,ET,ETS,ETX,HA,HAQ,HH,HTX,LD,LDB1,LDB3,LHE,LHZ,LJG1,LK,LM9,LNJ,LSS4,LW,LXZ,PA,PAE,P1,QA,QAE,QAQ,QAQ4,QDA,QHC,QHE,QHZ,QKA2,QMX2,QXB,QXEB,RA,RH,RHE,RHE4,SDB1,SH,SHE,SHEZ,SJC,SJP,SK,SNC1,SNE1,SW,SWE,SXB,SXE,SXEB,VA,VAH1,VNG,VTA,VTE2,VXP,VXQP,V1,WH,WKA
			(1)	(1)	-	4081304	EDN2,EDS1,EDS2,EDT1,ED2,ED4,ED5,ES1,ES3,HA2,HHQ4,HX,HXQ4,LH,LHE4,LJ,LJG,LKS,LNZ,LP,LSS5,LSX,LT,LX,LXQ4,LX2,L1,PA2,PMT2,PX,QAB2,QAE2,QAG2,QAR2,QA2,QC12,QD,QE,QH,QHP1,QHQ4,QMH,QP,QT,QTC2,QX,QXC,QXC9,QXE,QXE4,QXQ4,QXU,Q1,RA2,RD,RHQ4,RJ,RSC2,RSS1,RTB2,RX,RXQ4,R1,SD,SDB3,SE,SJ,SJC1,SJC5,SJG,SMS,SMX2,SNR,STP,STQ,SX,SXE4,SXQ4,SXU,S1,VA2,VDG2,VH,VH12,VMX,VSB1,VTA2,VWC2,VX,VXB,VXE,VXEB,VXQ4,VXU,VXU1,WJ,WKT2,WKT4,W1

Ref. No.	Part No.	Description	Reqd. QTY			Serial No.	Parts catalogue code
			(1)	(2)	(3)		
(1)	13010-ZE2-921	RING SET, PISTON (STD.) (TEIKOKU)	1	1	-	4081305	----- EDN2,EDS1,EDS2,EDT1,ED2,ED4,ED5,ES1,ES3,HA2,HHQ4,HX,HXQ4,LH,LHE4,LJ,LJG,LKS,LNZ,LP,LSS5,LSX,LT,LX,LXQ4,LX2,L1,PA2,PMT2,PX,QAB2,QAE2,QAG2,QAR2,QA2,QC12,QD,QE,QH,QHP1,QHQ4,QMH,QP,QT,QTC2,QX,QXC,QXC9,QXE,QXE4,QXQ4,QXU,Q1,RA2,RD,RHQ4,RJ,RSC2,RSS1,RTB2,RX,RXQ4,R1,SD,SDB3,SE,SJ,SJC1,SJC5,SJG,SMS,SMX2,SNR,STP,STQ,SX,SXE4,SXQ4,SXU,S1,VA2,VDG2,VH,VH12,VMX,VS1,VTA2,VWC2,VX,VXB,VXE,VXEB,VXQ4,VXU,VXU1,WJ,WKT2,WKT4,W1
			1	1	-	4869814	----- EDS1/A,EDT1/A,ED5/A,ES1/A,ES3/A,HX/A,LH/A,LJ/A,LJG/A,LJS/A,LKS/A,LP/A,LSX/A,LT/A,LX/A,LXF,L1/A,PX/A,QD/A,QH/A,QHP1/A,QMH/A,QP/A,QX/A,QXC/A,QXE/A,Q1/A,RD/A,RJ/A,RSS1/A,RX/A,R1/A,SD/A,SDB3/A,SHW/A,SJ/A,SJC1/A,SJC5/A,SJG/A,SMS/A,SNR/A,STP/A,SX/A,S1/A,VH/A,VS1/A,VS3,VX/A,VXE/A,VXEB/A,VXU/A,WJ/A,WMK,W1/A
			1	-	1	-----	----- EDN2/A,EDS2/A,EDS6,EDS6/A,EDT6,EDT6/A,ED2/A,ED4/A,EN2,EN2/A,HA2/A,HHQ4/A,HXQ4/A,LHE4/A,LJS,LSS5/A,LXQ4/A,LX2/A,PA2/A,PMT2/A,QAB2/A,QAE2/A,QAG,QAG/A,QAG2/A,QAR2/A,QA2/A,QC12/A,QE/A,QHB2,QHQ4/A,QT/A,QTC2/A,QW24,QXB7,QXB7/A,QXC9/A,QXE4/A,QXQ4/A,QXU/A,RA2/A,RHQ4/A,RTB2/A,RXQ4/A,SE/A,SHW,SMX2/A,STQ/A,SXE4/A,SXQ4/A,SXU/A,VA2/A,VDG2/A,VH12/A,VMT2,VTA2/A,VWC2/A,VXB/A,VXB7,VXB7/A,VXP/A,VXQ4/A,VXQ7,VXQ7/A,VXU1/A,WKD6,WKD6/A,WKT2/A,WKT4/A
	13010-ZE2-922	RING SET, PISTON (STD.) (NIPPON)	1	1	-	4081305	----- EDN2,EDS1,EDS2,EDT1,ED2,ED4,ED5,ES1,ES3,HA2,HHQ4,HX,HXQ4,LH,LHE4,LJ,LJG,LKS,LNZ,LP,LSS5,LSX,LT,LX,LXQ4,LX2,L1,PA2,PMT2,PX,QAB2,QAE2,QAG2,QAR2,QA2,QC12,QD,QE,QH,QHP1,QHQ4,QMH,QP,QT,QTC2,QX,QXC,QXC9,QXE,QXE4,QXQ4,QXU,Q1,RA2,RD,RHQ4,RJ,RSC2,RSS1,RTB2,RX,RXQ4,R1,SD,SDB3,SE,SJ,SJC1,SJC5,SJG,SMS,SMX2,SNR,STP,STQ,SX,SXE4,SXQ4,SXU,S1,VA2,VDG2,VH,VH12,VMX,VS1,VTA2,VWC2,VX,VXB,VXE,VXEB,VXQ4,VXU,VXU1,WJ,WKT2,WKT4,W1
			1	1	-	4869814	----- EDS1/A,EDT1/A,ED5/A,ES1/A,ES3/A,HX/A,LH/A,LJ/A,LJG/A,LJS/A,LKS/A,LP/A,LSX/A,LT/A,LX/A,LXF,L1/A,PX/A,QD/A,QH/A,QHP1/A,QMH/A,QP/A,QX/A,QXC/A,QXE/A,Q1/A,RD/A,RJ/A,RSS1/A,RX/A,R1/A,SD/A,SDB3/A,SHW/A,SJ/A,SJC1/A,SJC5/A,SJG/A,SMS/A,SNR/A,STP/A,SX/A,S1/A,VH/A,VS1/A,VS3,VX/A,VXE/A,VXEB/A,VXU/A,WJ/A,WMK,W1/A
			1	-	1	-----	----- EDN2/A,EDS2/A,EDS6,EDS6/A,EDT6,EDT6/A,ED2/A,ED4/A,EN2,EN2/A,HA2/A,HHQ4/A,HXQ4/A,LHE4/A,LJS,LSS5/A,LXQ4/A,LX2/A,PA2/A,PMT2/A,QAB2/A,QAE2/A,QAG,QAG/A,QAG2/A,QAR2/A,QA2/A,QC12/A,QE/A,QHB2,QHQ4/A,QT/A,QTC2/A,QW24,QXB7,QXB7/A,QXC9/A,QXE4/A,QXQ4/A,QXU/A,RA2/A,RHQ4/A,RTB2/A,RXQ4/A,SE/A,SHW,SMX2/A,STQ/A,SXE4/A,SXQ4/A,SXU/A,VA2/A,VDG2/A,VH12/A,VMT2,VTA2/A,VWC2/A,VXB/A,VXB7,VXB7/A,VXP/A,VXQ4/A,VXQ7,VXQ7/A,VXU1/A,WKD6,WKD6/A,WKT2/A,WKT4/A



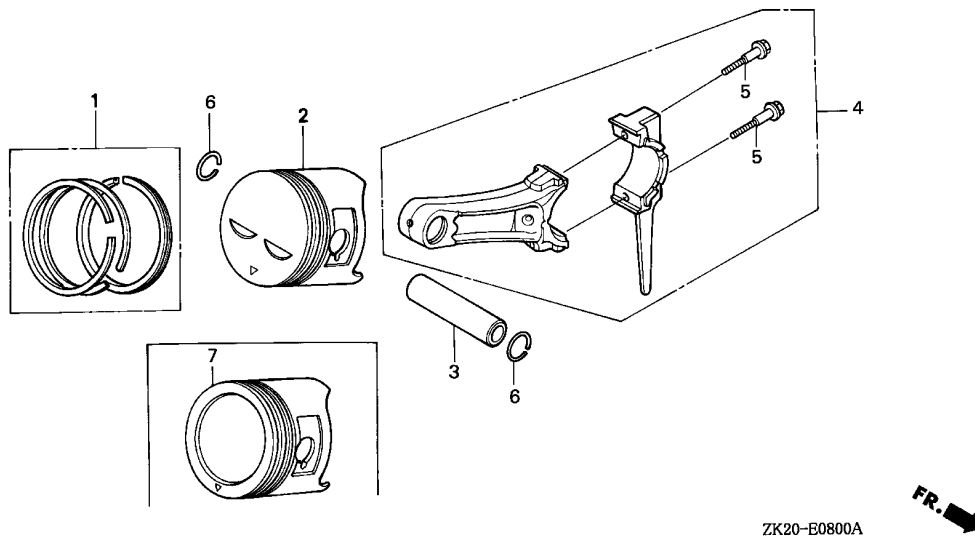

2

Ref. No.	Part No.	Description	Reqd. QTY			Serial No.	Parts catalogue code
			(1)	(2)	(3)		
(1)	13011-ZE2-921	RING SET, PISTON (0.25)					
		(TEIKOKU)	(1)	(1)	-	4081305	----- EDN2,EDS1,EDS2,EDT1,ED2,ED4,ED5,ES1,ES3,HA2,HHQ4,HX,HXQ4,LH,LHE4,LJ,LJG,LKS,LNZ,LP,LSS5,LSX,LT,LX,LXQ4,LX2,L1,PA2,PMT2,PX,QAB2,QAE2,QAG2,QAR2,QA2,QC12,QD,QE,QH,QHP1,QHQ4,QMH,QP,QT,QTC2,QX,QXC,QXC9,QXE,QXE4,QXQ4,QXU,Q1,RA2,RD,RHQ4,RJ,RSC2,RSS1,RTB2,RX,RXQ4,R1,SD,SDB3,SE,SJ,SJC1,SJC5,SJG,SMS,SMX2,SNR,STP,STQ,SX,SXE4,SXQ4,SXU,S1,VA2,VDG2,VH,VH12,VMX,VSU1,VTA2,VWC2,VX,VXB,VXE,VXEB,VXQ4,VXU,VXU1,WJ,WKT2,WKT4,W1
			(1)	(1)	-	4869814	----- EDS1/A,EDT1/A,ED5/A,ES1/A,ES3/A,HX/A,LH/A,LJ/A,LJG/A,LJS/A,LKS/A,LP/A,LSX/A,LT/A,LX/A,LXF,L1/A,PX/A,QD/A,QH/A,QHP1/A,QMH/A,QP/A,QX/A,QXC/A,QXE/A,Q1/A,RD/A,RJ/A,RSS1/A,RX/A,R1/A,SD/A,SDB3/A,SHW/A,SJ/A,SJC1/A,SJC5/A,SJG/A,SMS/A,SNR/A,STP/A,SX/A,S1/A,VH/A,VSU1/A,VS3,VX/A,VXE/A,VXEB/A,VXU/A,WJ/A,WKM,W1/A
			(1)	-	(1)	-----	----- EDN2/A,EDS2/A,EDS6,EDS6/A,EDT6,EDT6/A,ED2/A,ED4/A,EN2,EN2/A,HA2/A,HHQ4/A,HXQ4/A,LHE4/A,LJS,LSS5/A,LXQ4/A,LX2/A,PA2/A,PMT2/A,QAB2/A,QAE2/A,QAG,QAG/A,QAG2/A,QAR2/A,QA2/A,QC12/A,QE/A,QHB2,QHQ4/A,QT/A,QTC2/A,QW24,QXB7,QXB7/A,QXC9/A,QXE4/A,QXQ4/A,QXU/A,RA2/A,RHQ4/A,RTB2/A,RXQ4/A,SE/A,SHW,SMX2/A,STQ/A,SXE4/A,SXQ4/A,SXU/A,VA2/A,VDG2/A,VH12/A,VMT2,VTA2/A,VWC2/A,VXB/A,VXB7,VXB7/A,VXP/A,VXQ4/A,VXQ7,VXQ7/A,VXU1/A,WKD6,WKD6/A,WKT2/A,WKT4/A

Ref. No.	Part No.	Description	Reqd. QTY			Serial No.	Parts catalogue code
			(1)	(2)	(3)		
(1)	13011-ZE2-922	RING SET, PISTON (0.25) (NIPPON)	(1)	(1)	-	4081305	----- EDN2,EDS1,EDS2,EDT1,ED2,ED4,ED5,ES1,ES3,HA2,HHQ4,HX,HXQ4,LH,LHE4 LJ,LJG,LKS,LNZ,LP,LSS5,LSX,LT,LX,LXQ4,LX2,L1,PA2,PMT2,PX,QAB2 QAE2,QAG2,QAR2,QA2,QC12,QD,QE,QH,QHP1,QHQ4,QMH,QP,QT,QTC2,QX,QXC QXC9,QXE,QXE4,QXQ4,QXU,Q1,RA2,RD,RHQ4,RJ,RSC2,RSS1,RTB2,RX,RXQ4 R1,SD,SDB3,SE,SJ,SJC1,SJC5,SJG,SMS,SMX2,SNR,STP,STQ,SX,SXE4,SXQ4 SXU,S1,VA2,VDG2,VH,VH12,VMX,VS1,VTA2,VWC2,VX,VXB,VXE,VXEB,VXQ4 VXU,VXU1,WJ,WKT2,WKT4,W1
			(1)	(1)	-	4869814	----- EDS1/A,EDT1/A,ED5/A,ES1/A,ES3/A,HX/A,LH/A,LJ/A,LJG/A,LJS/A,LKS/A LP/A,LSX/A,LT/A,LX/A,LXF,L1/A,PX/A,QD/A,QH/A,QHP1/A,QMH/A,QP/A QX/A,QXC/A,QXE/A,Q1/A,RD/A,RJ/A,RSS1/A,RX/A,R1/A,SD/A,SDB3/A SHW/A,SJ/A,SJC1/A,SJC5/A,SJG/A,SMS/A,SNR/A,STP/A,SX/A,S1/A,VH/A VSB1/A,VS3,VX/A,VXE/A,VXEB/A,VXU/A,WJ/A,WMK,W1/A
			(1)	-	(1)	-----	----- EDN2/A,EDS2/A,EDS6,EDS6/A,EDT6,EDT6/A,ED2/A,ED4/A,EN2,EN2/A,HA2/A HHQ4/A,HXQ4/A,LHE4/A,LJS,LSS5/A,LXQ4/A,LX2/A,PA2/A,PMT2/A,QAB2/A QAE2/A,QAG,QAG/A,QAG2/A,QAR2/A,QA2/A,QC12/A,QE/A,QHB2,QHQ4/A,QT/A QTC2/A,QW24,QXB7,QXB7/A,QXC9/A,QXE4/A,QXQ4/A,QXU/A,RA2/A,RHQ4/A RTB2/A,RXQ4/A,SE/A,SHW,SMX2/A,STQ/A,SXE4/A,SXQ4/A,SXU/A,VA2/A VDG2/A,VH12/A,VMT2,VTA2/A,VWC2/A,VXB/A,VXB7,VXB7/A,VXP/A,VXQ4/A VXQ7,VXQ7/A,VXU1/A,WKD6,WKD6/A,WKT2/A,WKT4/A
	13012-ZE2-921	RING SET, PISTON (0.50) (TEIKOKU)	(1)	(1)	-	4081305	----- EDN2,EDS1,EDS2,EDT1,ED2,ED4,ED5,ES1,ES3,HA2,HHQ4,HX,HXQ4,LH,LHE4 LJ,LJG,LKS,LNZ,LP,LSS5,LSX,LT,LX,LXQ4,LX2,L1,PA2,PMT2,PX,QAB2 QAE2,QAG2,QAR2,QA2,QC12,QD,QE,QH,QHP1,QHQ4,QMH,QP,QT,QTC2,QX,QXC QXC9,QXE,QXE4,QXQ4,QXU,Q1,RA2,RD,RHQ4,RJ,RSC2,RSS1,RTB2,RX,RXQ4 R1,SD,SDB3,SE,SJ,SJC1,SJC5,SJG,SMS,SMX2,SNR,STP,STQ,SX,SXE4,SXQ4 SXU,S1,VA2,VDG2,VH,VH12,VMX,VS1,VTA2,VWC2,VX,VXB,VXE,VXEB,VXQ4 VXU,VXU1,WJ,WKT2,WKT4,W1
			(1)	(1)	-	4869814	----- EDS1/A,EDT1/A,ED5/A,ES1/A,ES3/A,HX/A,LH/A,LJ/A,LJG/A,LJS/A,LKS/A LP/A,LSX/A,LT/A,LX/A,LXF,L1/A,PX/A,QD/A,QH/A,QHP1/A,QMH/A,QP/A QX/A,QXC/A,QXE/A,Q1/A,RD/A,RJ/A,RSS1/A,RX/A,R1/A,SD/A,SDB3/A SHW/A,SJ/A,SJC1/A,SJC5/A,SJG/A,SMS/A,SNR/A,STP/A,SX/A,S1/A,VH/A VSB1/A,VS3,VX/A,VXE/A,VXEB/A,VXU/A,WJ/A,WMK,W1/A
			(1)	-	(1)	-----	----- EDN2/A,EDS2/A,EDS6,EDS6/A,EDT6,EDT6/A,ED2/A,ED4/A,EN2,EN2/A,HA2/A HHQ4/A,HXQ4/A,LHE4/A,LJS,LSS5/A,LXQ4/A,LX2/A,PA2/A,PMT2/A,QAB2/A QAE2/A,QAG,QAG/A,QAG2/A,QAR2/A,QA2/A,QC12/A,QE/A,QHB2,QHQ4/A,QT/A QTC2/A,QW24,QXB7,QXB7/A,QXC9/A,QXE4/A,QXQ4/A,QXU/A,RA2/A,RHQ4/A RTB2/A,RXQ4/A,SE/A,SHW,SMX2/A,STQ/A,SXE4/A,SXQ4/A,SXU/A,VA2/A VDG2/A,VH12/A,VMT2,VTA2/A,VWC2/A,VXB/A,VXB7,VXB7/A,VXP/A,VXQ4/A VXQ7,VXQ7/A,VXU1/A,WKD6,WKD6/A,WKT2/A,WKT4/A

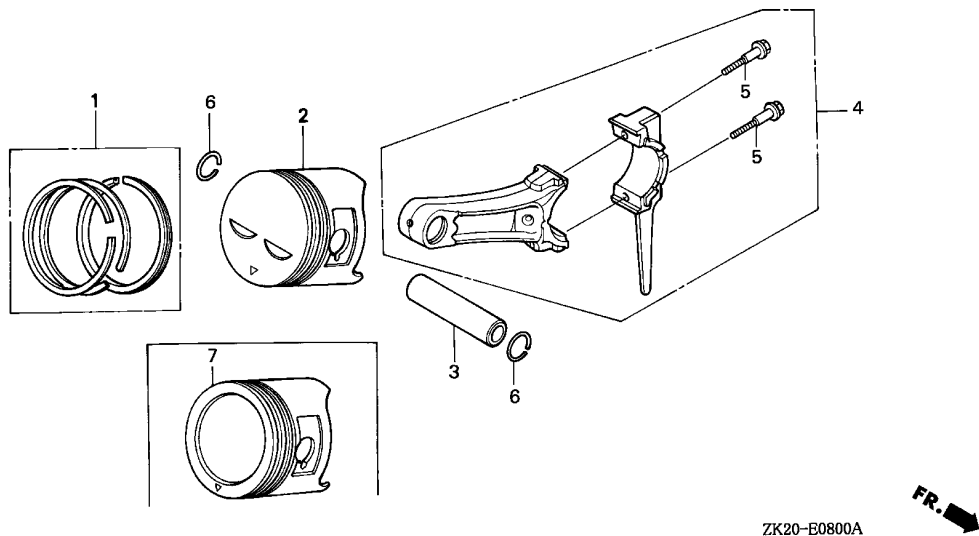

2

Ref. No.	Part No.	Description	Reqd. QTY			Serial No.	Parts catalogue code
			(1)	(2)	(3)		
(1)	13012-ZE2-922	RING SET, PISTON (0.50)					
		(NIPPON)	(1)	(1)	-	4081305	----- EDN2,EDS1,EDS2,EDT1,ED2,ED4,ED5,ES1,ES3,HA2,HHQ4,HX,HXQ4,LH,LHE4 LJ,LJG,LKS,LNZ,LP,LSS5,LSX,LT,LX,LXQ4,LX2,L1,PA2,PMT2,PX,QAB2 QAE2,QAG2,QAR2,QA2,QC12,QD,QE,QH,QHP1,QHQ4,QMH,QP,QT,QTC2,QX,QXC QXC9,QXE,QXE4,QXQ4,QXU,Q1,RA2,RD,RHQ4,RJ,RSC2,RSS1,RTB2,RX,RXQ4 R1,SD,SDB3,SE,SJ,SJC1,SJC5,SJG,SMS,SMX2,SNR,STP,STQ,SX,SXE4,SXQ4 SXU,S1,VA2,VDG2,VH,VH12,VMX,VSU,VSA2,VVC2,VX,VXB,VXE,VXEB,VXQ4 VXU,VXU1,WJ,WKT2,WKT4,W1
			(1)	(1)	-	4869814	----- EDS1/A,EDT1/A,ED5/A,ES1/A,ES3/A,HX/A,LH/A,LJ/A,LJG/A,LJS/A,LKS/A LP/A,LSX/A,LT/A,LX/A,LXF,L1/A,PX/A,QD/A,QH/A,QHP1/A,QMH/A,QP/A QX/A,QXC/A,QXE/A,Q1/A,RD/A,RJ/A,RSS1/A,RX/A,R1/A,SD/A,SDB3/A SHW/A,SJ/A,SJC1/A,SJC5/A,SJG/A,SMS/A,SNR/A,STP/A,SX/A,S1/A,VH/A VSB1/A,VS3,VX/A,VXE/A,VXEB/A,VXU/A,WJ/A,WMK,W1/A
			(1)	-	(1)	-----	----- EDN2/A,EDS2/A,EDS6,EDS6/A,EDT6,EDT6/A,ED2/A,ED4/A,EN2,EN2/A,HA2/A HHQ4/A,HXQ4/A,LHE4/A,LJS,LSS5/A,LXQ4/A,LX2/A,PA2/A,PMT2/A,QAB2/A QAE2/A,QAG,QAG/A,QAG2/A,QAR2/A,QA2/A,QC12/A,QE/A,QHB2,QHQ4/A,QT/A QTC2/A,QW24,QXB7,QXB7/A,QXC9/A,QXE4/A,QXQ4/A,QXU/A,RA2/A,RHQ4/A RTB2/A,RXQ4/A,SE/A,SHW,SMX2/A,STQ/A,SXE4/A,SXQ4/A,SXU/A,VA2/A VDG2/A,VH12/A,VMT2,VT2/A,VVC2/A,VXB/A,VXB7,VXB7/A,VXP/A,VXQ4/A VXQ7,VXQ7/A,VXU1/A,WKD6,WKD6/A,WKT2/A,WKT4/A

Ref. No.	Part No.	Description	Reqd. QTY			Serial No.	Parts catalogue code
			(1)	(2)	(3)		
(1)	13013-ZE2-921	RING SET, PISTON (0.75) (TEIKOKU)	(1)	(1)	-	4081305	----- EDN2,EDS1,EDS2,EDT1,ED2,ED4,ED5,ES1,ES3,HA2,HHQ4,HX,HXQ4,LH,LHE4,LJ,LJG,LKS,LNZ,LP,LSS5,LSX,LT,LX,LXQ4,LX2,L1,PA2,PMT2,PX,QAB2,QAE2,QAG2,QAR2,QA2,QC12,QD,QE,QH,QHP1,QHQ4,QMH,QP,QT,QTC2,QX,QXC,QXC9,QXE,QXE4,QXQ4,QXU,Q1,RA2,RD,RHQ4,RJ,RSC2,RSS1,RTB2,RX,RXQ4,R1,SD,SDB3,SE,SJ,SJC1,SJC5,SJG,SMS,SMX2,SNR,STP,STQ,SX,SXE4,SXQ4,SXU,S1,VA2,VDG2,VH,VH12,VMX,VS1,VTA2,VWC2,VX,VXB,VXE,VXEB,VXQ4,VXU,VXU1,WJ,WKT2,WKT4,W1
			(1)	(1)	-	4869814	----- EDS1/A,EDT1/A,ED5/A,ES1/A,ES3/A,HX/A,LH/A,LJ/A,LJG/A,LJS/A,LKS/A,LP/A,LSX/A,LT/A,LX/A,LXF,L1/A,PX/A,QD/A,QH/A,QHP1/A,QMH/A,QP/A,QX/A,QXC/A,QXE/A,Q1/A,RD/A,RJ/A,RSS1/A,RX/A,R1/A,SD/A,SDB3/A,SHW/A,SJ/A,SJC1/A,SJC5/A,SJG/A,SMS/A,SNR/A,STP/A,SX/A,S1/A,VH/A,VS1/A,VS3,VX/A,VXE/A,VXEB/A,VXU/A,WJ/A,WMK,W1/A
			(1)	-	(1)	-----	----- EDN2/A,EDS2/A,EDS6,EDS6/A,EDT6,EDT6/A,ED2/A,ED4/A,EN2,EN2/A,HA2/A,HHQ4/A,HXQ4/A,LHE4/A,LJS,LSS5/A,LXQ4/A,LX2/A,PA2/A,PMT2/A,QAB2/A,QAE2/A,QAG,QAG/A,QAG2/A,QAR2/A,QA2/A,QC12/A,QE/A,QHB2,QHQ4/A,QT/A,QTC2/A,QW24,QXB7,QXB7/A,QXC9/A,QXE4/A,QXQ4/A,QXU/A,RA2/A,RHQ4/A,RTB2/A,RXQ4/A,SE/A,SHW,SMX2/A,STQ/A,SXE4/A,SXQ4/A,SXU/A,VA2/A,VDG2/A,VH12/A,VMT2,VTA2/A,VWC2/A,VXB/A,VXB7,VXB7/A,VXP/A,VXQ4/A,VXQ7,VXQ7/A,VXU1/A,WKD6,WKD6/A,WKT2/A,WKT4/A
	13013-ZE2-922	RING SET, PISTON (0.75) (NIPPON)	(1)	(1)	-	4081305	----- EDN2,EDS1,EDS2,EDT1,ED2,ED4,ED5,ES1,ES3,HA2,HHQ4,HX,HXQ4,LH,LHE4,LJ,LJG,LKS,LNZ,LP,LSS5,LSX,LT,LX,LXQ4,LX2,L1,PA2,PMT2,PX,QAB2,QAE2,QAG2,QAR2,QA2,QC12,QD,QE,QH,QHP1,QHQ4,QMH,QP,QT,QTC2,QX,QXC,QXC9,QXE,QXE4,QXQ4,QXU,Q1,RA2,RD,RHQ4,RJ,RSC2,RSS1,RTB2,RX,RXQ4,R1,SD,SDB3,SE,SJ,SJC1,SJC5,SJG,SMS,SMX2,SNR,STP,STQ,SX,SXE4,SXQ4,SXU,S1,VA2,VDG2,VH,VH12,VMX,VS1,VTA2,VWC2,VX,VXB,VXE,VXEB,VXQ4,VXU,VXU1,WJ,WKT2,WKT4,W1
			(1)	(1)	-	4869814	----- EDS1/A,EDT1/A,ED5/A,ES1/A,ES3/A,HX/A,LH/A,LJ/A,LJG/A,LJS/A,LKS/A,LP/A,LSX/A,LT/A,LX/A,LXF,L1/A,PX/A,QD/A,QH/A,QHP1/A,QMH/A,QP/A,QX/A,QXC/A,QXE/A,Q1/A,RD/A,RJ/A,RSS1/A,RX/A,R1/A,SD/A,SDB3/A,SHW/A,SJ/A,SJC1/A,SJC5/A,SJG/A,SMS/A,SNR/A,STP/A,SX/A,S1/A,VH/A,VS1/A,VS3,VX/A,VXE/A,VXEB/A,VXU/A,WJ/A,WMK,W1/A
			(1)	-	(1)	-----	----- EDN2/A,EDS2/A,EDS6,EDS6/A,EDT6,EDT6/A,ED2/A,ED4/A,EN2,EN2/A,HA2/A,HHQ4/A,HXQ4/A,LHE4/A,LJS,LSS5/A,LXQ4/A,LX2/A,PA2/A,PMT2/A,QAB2/A,QAE2/A,QAG,QAG/A,QAG2/A,QAR2/A,QA2/A,QC12/A,QE/A,QHB2,QHQ4/A,QT/A,QTC2/A,QW24,QXB7,QXB7/A,QXC9/A,QXE4/A,QXQ4/A,QXU/A,RA2/A,RHQ4/A,RTB2/A,RXQ4/A,SE/A,SHW,SMX2/A,STQ/A,SXE4/A,SXQ4/A,SXU/A,VA2/A,VDG2/A,VH12/A,VMT2,VTA2/A,VWC2/A,VXB/A,VXB7,VXB7/A,VXP/A,VXQ4/A,VXQ7,VXQ7/A,VXU1/A,WKD6,WKD6/A,WKT2/A,WKT4/A



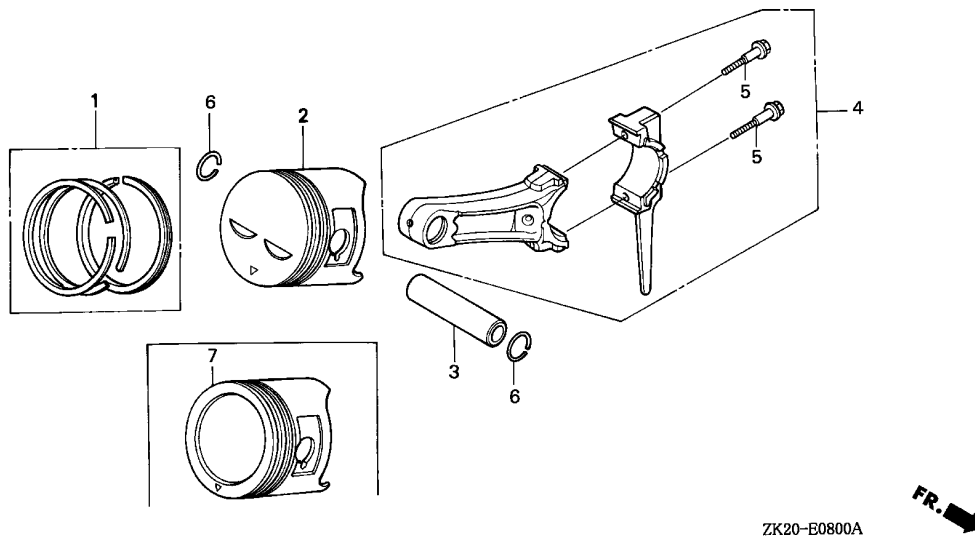

ZK20-E0800A

Ref. No.	Part No.	Description	Reqd. QTY			Serial No.	Parts catalogue code
			(1)	(2)	(3)		
(1)	13010-Z5F-004	RING SET, PISTON (STD.) (TEIKOKU)	1	1	-	4081305 -----	EDN2,EDS1,EDS2,EDT1,ED2,ED4,ED5,ES1,ES3,HA2,HHQ4,HX,HXQ4,LH,LHE4,LJ,LJG,LKS,LNZ,LP,LSS5,LSX,LT,LX,LXQ4,LX2,L1,PA2,PMT2,PX,QAB2,QAE2,QAG2,QAR2,QA2,QC12,QD,QE,QH,QHP1,QHQ4,QMH,QP,QT,QTC2,QX,QXC,QXC9,QXE,QXE4,QXQ4,QXU,Q1,RA2,RD,RHQ4,RJ,RSC2,RSS1,RTB2,RX,RXQ4,R1,SD,SDB3,SE,SJ,SJC1,SJC5,SJG,SMS,SMX2,SNR,STP,STQ,SX,SXE4,SXQ4,SXU,S1,VA2,VDG2,VH,VH12,VMX,VS1,VTA2,VWC2,VX,VXB,VXE,VXEB,VXQ4,VXU,VXU1,WJ,WKT2,WKT4,W1
			1	1	-	4869815 -----	EDS1/A,EDT1/A,ED5/A,ES1/A,ES3/A,HX/A,LH/A,LJ/A,LJG/A,LJS/A,LKS/A,LP/A,LSX/A,LT/A,LX/A,LXF,L1/A,PX/A,QD/A,QH/A,QHP1/A,QMH/A,QP/A,QX/A,QXC/A,QXE/A,Q1/A,RD/A,RJ/A,RSS1/A,RX/A,R1/A,SD/A,SDB3/A,SHW/A,SJ/A,SJC1/A,SJC5/A,SJG/A,SMS/A,SNR/A,STP/A,SX/A,S1/A,VH/A,VS1/A,VS3,VX/A,VXE/A,VXEB/A,VXU/A,WJ/A,WMK,W1/A
			1	-	-	-----	EDN2/A,EDS2/A,EDS6/A,EDT3,EDT6,EDT6/A,ED2/A,ED4/A,EN2,EN2/A,ES2,HA2/A,HHQ4/A,HXQ4/A,LHE4/A,LJS,LSS5/A,LXQ4/A,LX2/A,PA2/A,PMT2/A,QAB2/A,QAE2/A,QAG,QAG/A,QAG2/A,QAR2/A,QA2/A,QC12/A,QE/A,QHB2,QHQ4/A,QTC2/A,QW24,QXB7,QXB7/A,QXC9/A,QXE4/A,QXQ4/A,QXU/A,RA2/A,RHQ4/A,RTB2/A,RXQ4/A,SE/A,SHW,SMX2/A,STQ/A,SXE4/A,SXQ4/A,SXU/A,VA2/A,VDG2/A,VH12/A,VMT2,VS4,VTA2/A,VWC2/A,VXB7/A,VXB7/A,VXQ4/A,VXQ7/A,VXU1/A,WKD6,WKD6/A,WKT2/A,WKT4/A
	13011-Z5F-004	RING SET, PISTON (0.25) (TEIKOKU)	(1)	(1)	-	4869815 -----	EDS1/A,EDT1/A,ED5/A,ES1/A,ES3/A,HX/A,LH/A,LJ/A,LJG/A,LJS/A,LKS/A,LP/A,LSX/A,LT/A,LX/A,LXF,L1/A,PX/A,QD/A,QH/A,QHP1/A,QMH/A,QP/A,QX/A,QXC/A,QXE/A,Q1/A,RD/A,RJ/A,RSS1/A,RX/A,R1/A,SD/A,SDB3/A,SHW/A,SJ/A,SJC1/A,SJC5/A,SJG/A,SMS/A,SNR/A,STP/A,SX/A,S1/A,VH/A,VS1/A,VS3,VX/A,VXE/A,VXEB/A,VXU/A,WJ/A,WMK,W1/A
			(1)	-	-	-----	EDT3,ES2,VS4

Ref. No.	Part No.	Description	Reqd. QTY			Serial No.	Parts catalogue code
			(1)	(2)	(3)		
(1)	13012-Z5F-004	RING SET, PISTON (0.50) (TEIKOKU)	(1)	(1)	-	4869815	----- EDS1/A,EDT1/A,ED5/A,ES1/A,ES3/A,HX/A,LH/A,LJ/A,LJG/A,LJS/A,LKS/A LP/A,LSX/A,LT/A,LX/A,LXF,L1/A,PX/A,QD/A,QH/A,QHP1/A,QMH/A,QP/A QX/A,QXC/A,QXE/A,Q1/A,RD/A,RJ/A,RSS1/A,RX/A,R1/A,SD/A,SDB3/A SHW/A,SJ/A,SJC1/A,SJC5/A,SJG/A,SMS/A,SNR/A,STP/A,SX/A,S1/A,VH/A VSB1/A,VS3,VX/A,VXE/A,VXEB/A,VXU/A,WJ/A,WMK,W1/A
			(1)	-	-	-----	EDT3,ES2,VS4
	13013-Z5F-004	RING SET, PISTON (0.75) (TEIKOKU)	(1)	(1)	-	4869815	----- EDS1/A,EDT1/A,ED5/A,ES1/A,ES3/A,HX/A,LH/A,LJ/A,LJG/A,LJS/A,LKS/A LP/A,LSX/A,LT/A,LX/A,LXF,L1/A,PX/A,QD/A,QH/A,QHP1/A,QMH/A,QP/A QX/A,QXC/A,QXE/A,Q1/A,RD/A,RJ/A,RSS1/A,RX/A,R1/A,SD/A,SDB3/A SHW/A,SJ/A,SJC1/A,SJC5/A,SJG/A,SMS/A,SNR/A,STP/A,SX/A,S1/A,VH/A VSB1/A,VS3,VX/A,VXE/A,VXEB/A,VXU/A,WJ/A,WMK,W1/A
			(1)	-	-	-----	EDT3,ES2,VS4
2	13101-ZE2-W00	PISTON (STD.)	1	1	-	-----	EDN,EDN2,EDN2/A,EDS,EDS1,EDS2,EDS2/A,EDS3,EDS5,EDS6,EDS6/A,EDT1 EDT2,EDT6,EDT6/A,ED2,ED2/A,ED3,ED4,ED4/A,ED5,EN,EN2,EN2/A,ES,ES1 ES3,ET,ETS,ETX,HA,HAQ,HA2,HA2/A,HH,HHQ4,HHQ4/A,HTX,HX,HXQ4,HXQ4/A LD,LDB1,LDB3,LH,LHE,LHE4,LHE4/A,LHZ,LJ,LJG,LJG1,LJS,LK,LKS,LM9 LNJ,LNZ,LP,LSS4,LSS5,LSS5/A,LSX,LT,LW,LX,LXQ4,LXQ4/A,LXZ,LX2 LX2/A,L1,PA,PAE,PA2,PA2/A,PMT2,PMT2/A,PX,P1,QA,QAB2,QAB2/A,QAE QAE2,QAE2/A,QAG,QAG/A,QAG2,QAG2/A,QAQ,QAQ4,QAR2,QAR2/A,QA2,QA2/A QC12,QC12/A,QD,QE,QE/A,QH,QHB2,QHC,QHE,QHP1,QHQ4,QHQ4/A,QHZ,QKA2 QMH,QMX2,QP,QTC2,QTC2/A,QW24,QX,QXB,QXB7,QXB7/A,QXC,QXC9,QXC9/A QXE,QXEB,QXE4,QXE4/A,QXQ4,QXQ4/A,QXU,QXU/A,Q1,RA,RA2,RA2/A,RD,RH RHE,RHE4,RHQ4,RHQ4/A,RJ,RSC2,RSS1,RTB2,RTB2/A,RX,RXQ4,RXQ4/A,R1 SD,SDB1,SDB3,SE,SE/A,SH,SHE,SHEZ,SHW,SJ,SJC,SJC1,SJC5,SJG,SJP,SK SMS,SMX2,SMX2/A,SNC1,SNE1,SNR,STP,STQ,STQ/A,SW,SWE,SX,SBX,SXE SXEB,SXE4,SXE4/A,SXQ4,SXQ4/A,SXU,SXU/A,S1,VA,VAH1,VA2,VA2/A,VDG2 VDG2/A,VH,VH12,VH12/A,VMT2,VMX,VNG,VSB1,VTA,VTA2,VTA2/A,VTE2,VWC2 VWC2/A,VX,VXB,VXB/A,VXB7,VXB7/A,VXE,VXEB,VXQ4,VXQ4/A,VXQ7,VXQ7/A VXU,VXU1,VXU1/A,V1,WH,WJ,WKA,WKD6,WKD6/A,WKT2,WKT2/A,WKT4,WKT4/A W1
			1	1	-	4869814	----- EDS1/A,EDT1/A,ED5/A,ES1/A,ES3/A,HX/A,LH/A,LJ/A,LJG/A,LJS/A,LKS/A LP/A,LSX/A,LT/A,LX/A,LXF,L1/A,PX/A,QD/A,QH/A,QHP1/A,QMH/A,QP/A QX/A,QXC/A,QXE/A,Q1/A,RD/A,RJ/A,RSS1/A,RX/A,R1/A,SD/A,SDB3/A SHW/A,SJ/A,SJC1/A,SJC5/A,SJG/A,SMS/A,SNR/A,STP/A,SX/A,S1/A,VH/A VSB1/A,VS3,VX/A,VXE/A,VXEB/A,VXU/A,WJ/A,WMK,W1/A
			-	-	-	-----	1



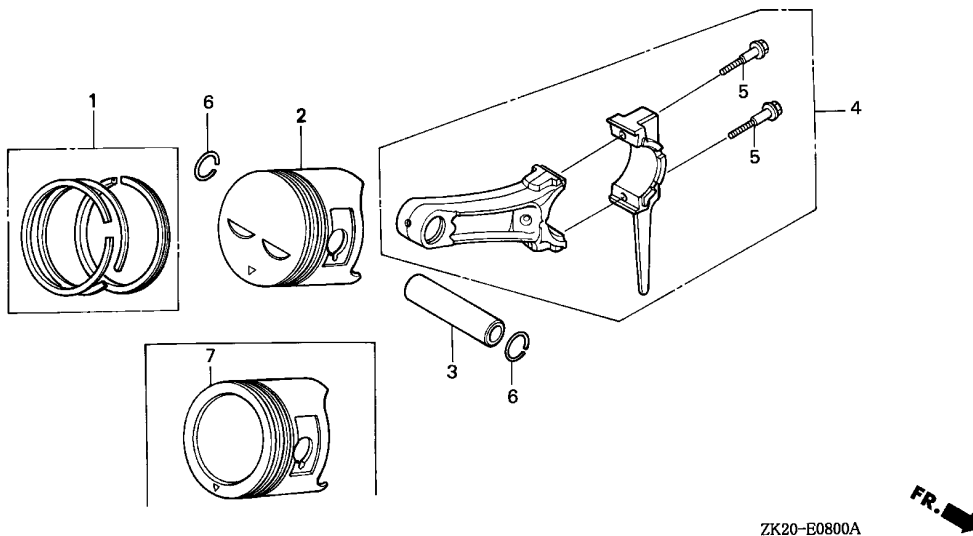

ZK20-E0800A

Ref. No.	Part No.	Description	Reqd. QTY			Serial No.	Parts catalogue code
			(1)	(2)	(3)		
(2)	13102-ZE2-W00	PISTON (0.25)	(1)	(1)	-		EDN,EDN2,EDN2/A,EDS,EDS1,EDS2,EDS2/A,EDS3,EDS5,EDS6,EDS6/A,EDT1,EDT2,EDT6,EDT6/A,ED2,ED2/A,ED3,ED4,ED4/A,ED5,EN,EN2,EN2/A,ES,ES1,ES3,ET,ETS,ETX,HA,HAQ,HA2,HA2/A,HH,HHQ4,HHQ4/A,HTX,HX,HXQ4,HXQ4/A,LD,LDB1,LDB3,LH,LHE,LHE4,LHE4/A,LHZ,LJ,LJG,LJG1,LJS,LK,LKS,LM9,LNJ,LNZ,LP,LSS4,LSS5,LSS5/A,LSX,LT,LW,LX,LXQ4,LXQ4/A,LXZ,LX2,LX2/A,L1,PA,PAE,PA2,PA2/A,PMT2,PMT2/A,PX,P1,QA,QAB2,QAB2/A,QAE,QAE2,QAE2/A,QAG,QAG/A,QAG2,QAG2/A,QAQ,QAQ4,QAR2,QAR2/A,QA2,QA2/A,QC12,QC12/A,QD,QE,QE/A,QH,QHB2,QHC,QHE,QHP1,QHQ4,QHQ4/A,QHZ,QKA2,QMH,QMX2,QP,QTC2,QTC2/A,QW24,QX,QXB,QXB7,QXB7/A,QXC,QXC9,QXC9/A,QXE,QXEB,QXE4,QXE4/A,QXQ4,QXQ4/A,QXU,QXU/A,Q1,RA,RA2,RA2/A,RD,RH,RHE,RHE4,RHQ4,RHQ4/A,RJ,RSC2,RSS1,RTB2,RTB2/A,RX,RXQ4,RXQ4/A,R1,SD,SDB1,SDB3,SE,SE/A,SH,SHE,SHEZ,SHW,SJ,SJC,SJC1,SJC5,SJG,SJP,SK,SMS,SMX2,SMX2/A,SNC1,SNE1,SNR,STP,STQ,STQ/A,SW,SWE,SX,SBX,SXE,SXEB,SXE4,SXE4/A,SXQ4,SXQ4/A,SXU,SXU/A,S1,VA,VAH1,VA2,VA2/A,VDG2,VDG2/A,VH,VH12,VH12/A,VMT2,VMX,VNG,VS1,VTA,VTA2,VTA2/A,VTE2,VWC2,VWC2/A,VX,VXB,VXB7,VXB7/A,VXE,VXEB,VXQ4,VXQ4/A,VXQ7,VXQ7/A,VXU,VXU1,VXU1/A,V1,WH,WJ,WKA,WKD6,WKD6/A,WKT2,WKT2/A,WKT4,WKT4/A,W1
			(1)	(1)	-	4869814	EDS1/A,EDT1/A,ED5/A,ES1/A,ES3/A,HX/A,LH/A,LJ/A,LJG/A,LJS/A,LKS/A,LP/A,LSX/A,LT/A,LX/A,LXF,L1/A,PX/A,QD/A,QH/A,QHP1/A,QMH/A,QP/A,QX/A,QXC/A,QXE/A,Q1/A,RD/A,RJ/A,RSS1/A,RX/A,R1/A,SD/A,SDB3/A,SHW/A,SJ/A,SJC1/A,SJC5/A,SJG/A,SMS/A,SNR/A,STP/A,SX/A,S1/A,VH/A,VS1/A,VS3,VX/A,VXE/A,VXEB/A,VXU/A,WJ/A,WMK,W1/A
			-	-	(1)		

Ref. No.	Part No.	Description	Reqd. QTY		Serial No.	Parts catalogue code
			(1)	(2)		
(2)	13103-ZE2-W00	PISTON (0.50)	(1)	(1)	-	EDN,EDN2,EDN2/A,EDS,EDS1,EDS2,EDS2/A,EDS3,EDS5,EDS6,EDS6/A,EDT1,EDT2,EDT6,EDT6/A,ED2,ED2/A,ED3,ED4,ED4/A,ED5,EN,EN2,EN2/A,ES,ES1,ES3,ET,ETS,ETX,HA,HAQ,HA2,HA2/A,HH,HHQ4,HHQ4/A,HTX,HX,HXQ4,HXQ4/A,LD,LDB1,LDB3,LH,LHE,LHE4,LHE4/A,LHZ,LJ,LJG,LJG1,LJS,LK,LKS,LM9,LNJ,LNZ,LP,LSS4,LSS5,LSS5/A,LSX,LT,LW,LX,LXQ4,LXQ4/A,LXZ,LX2,LX2/A,L1,PA,PAE,PA2,PA2/A,PMT2,PMT2/A,PX,P1,QA,QAB2,QAB2/A,QAQ,QAQ2,QAQ2/A,QAQ,QAQ/A,QAQ2,QAQ2/A,QAQ,QAQ4,QAQ2,QAQ2/A,QA2,QA2/A,QC12,QC12/A,QD,QE,QE/A,QH,QHB2,QHC,QHE,QHP1,QHQ4,QHQ4/A,QHZ,QKA2,QMH,QMX2,QP,QTC2,QTC2/A,QW24,QX,QXB,QXB7,QXB7/A,QXC,QXC9,QXC9/A,QXE,QXEB,QXE4,QXE4/A,QXQ4,QXQ4/A,QXU,QXU/A,Q1,RA,RA2,RA2/A,RD,RH,RHE,RHE4,RHQ4,RHQ4/A,RJ,RSC2,RSS1,RTB2,RTB2/A,RX,RXQ4,RXQ4/A,R1,SD,SDB1,SDB3,SE,SE/A,SH,SHE,SHEZ,SHW,SJ,SJC,SJC1,SJC5,SJG,SJP,SK,SMS,SMX2,SMX2/A,SNC1,SNE1,SNR,STP,STQ,STQ/A,SW,SWE,SX,SXB,SXE,SXEB,SXE4,SXE4/A,SXQ4,SXQ4/A,SXU,SXU/A,S1,VA,VAH1,VA2,VA2/A,VDG2,VDG2/A,VH,VH12,VH12/A,VMT2,VMX,VNG,VS1,VTA,VTA2,VTA2/A,VTE2,VWC2,VWC2/A,VX,VXB,VXB/A,VXB7,VXB7/A,VXE,VXEB,VXQ4,VXQ4/A,VXQ7,VXQ7/A,VXU,VXU1,VXU1/A,V1,WH,WJ,WKA,WKD6,WKD6/A,WKT2,WKT2/A,WKT4,WKT4/A,W1
			(1)	(1)	-	4869814 EDS1/A,EDT1/A,ED5/A,ES1/A,ES3/A,HX/A,LH/A,LJ/A,LJG/A,LJS/A,LKS/A,LP/A,LSX/A,LT/A,LX/A,LXF,L1/A,PX/A,QD/A,QH/A,QHP1/A,QMH/A,QP/A,QX/A,QXC/A,QXE/A,Q1/A,RD/A,RJ/A,RSS1/A,RX/A,R1/A,SD/A,SDB3/A,SHW/A,SJ/A,SJC1/A,SJC5/A,SJG/A,SMS/A,SNR/A,STP/A,STQ/A,VAH1/A,VH/A,VS1/A,VS3/A,VX/A,VXE/A,VXEB/A,VXU/A,WJ/A,WKM,W1/A
	13104-ZE2-W00	PISTON (0.75)	(1)	(1)	(1)	EDN,EDN2,EDN2/A,EDS,EDS1,EDS2,EDS2/A,EDS3,EDS5,EDS6,EDS6/A,EDT1,EDT2,EDT6,EDT6/A,ED2,ED2/A,ED3,ED4,ED4/A,ED5,EN,EN2,EN2/A,ES,ES1,ES3,ET,ETS,ETX,HA,HAQ,HA2,HA2/A,HH,HHQ4,HHQ4/A,HTX,HX,HXQ4,HXQ4/A,LD,LDB1,LDB3,LH,LHE,LHE4,LHE4/A,LHZ,LJ,LJG,LJG1,LJS,LK,LKS,LM9,LNJ,LNZ,LP,LSS4,LSS5,LSS5/A,LSX,LT,LW,LX,LXQ4,LXQ4/A,LXZ,LX2,LX2/A,L1,PA,PAE,PA2,PA2/A,PMT2,PMT2/A,PX,P1,QA,QAB2,QAB2/A,QAQ,QAQ2,QAQ2/A,QAQ,QAQ/A,QAQ2,QAQ2/A,QAQ,QAQ4,QAQ2,QAQ2/A,QA2,QA2/A,QC12,QC12/A,QD,QE,QE/A,QH,QHB2,QHC,QHE,QHP1,QHQ4,QHQ4/A,QHZ,QKA2,QMH,QMX2,QP,QTC2,QTC2/A,QW24,QX,QXB,QXB7,QXB7/A,QXC,QXC9,QXC9/A,QXE,QXEB,QXE4,QXE4/A,QXQ4,QXQ4/A,QXU,QXU/A,Q1,RA,RA2,RA2/A,RD,RH,RHE,RHE4,RHQ4,RHQ4/A,RJ,RSC2,RSS1,RTB2,RTB2/A,RX,RXQ4,RXQ4/A,R1,SD,SDB1,SDB3,SE,SE/A,SH,SHE,SHEZ,SHW,SJ,SJC,SJC1,SJC5,SJG,SJP,SK,SMS,SMX2,SMX2/A,SNC1,SNE1,SNR,STP,STQ,STQ/A,SW,SWE,SX,SXB,SXE,SXEB,SXE4,SXE4/A,SXQ4,SXQ4/A,SXU,SXU/A,S1,VA,VAH1,VA2,VA2/A,VDG2,VDG2/A,VH,VH12,VH12/A,VMT2,VMX,VNG,VS1,VTA,VTA2,VTA2/A,VTE2,VWC2,VWC2/A,VX,VXB,VXB/A,VXB7,VXB7/A,VXE,VXEB,VXQ4,VXQ4/A,VXQ7,VXQ7/A,VXU,VXU1,VXU1/A,V1,WH,WJ,WKA,WKD6,WKD6/A,WKT2,WKT2/A,WKT4,WKT4/A,W1
			(1)	(1)	(1)	4869814 EDS1/A,EDT1/A,ED5/A,ES1/A,ES3/A,HX/A,LH/A,LJ/A,LJG/A,LJS/A,LKS/A,LP/A,LSX/A,LT/A,LX/A,LXF,L1/A,PX/A,QD/A,QH/A,QHP1/A,QMH/A,QP/A,QX/A,QXC/A,QXE/A,Q1/A,RD/A,RJ/A,RSS1/A,RX/A,R1/A,SD/A,SDB3/A,SHW/A,SJ/A,SJC1/A,SJC5/A,SJG/A,SMS/A,SNR/A,STP/A,STQ/A,VAH1/A,VH/A,VS1/A,VS3/A,VX/A,VXE/A,VXEB/A,VXU/A,WJ/A,WKM,W1/A
	13101-ZE2-W01	PISTON (STD.)	1	1	(1)	EDS1/A,EDT1/A,ED5/A,ES1/A,ES3/A,HX/A,LH/A,LJ/A,LJG/A,LJS/A,LKS/A,LP/A,LSX/A,LT/A,LX/A,LXF,L1/A,PX/A,QD/A,QH/A,QHP1/A,QMH/A,QP/A,QX/A,QXC/A,QXE/A,Q1/A,RD/A,RJ/A,RSS1/A,RX/A,R1/A,SD/A,SDB3/A,SHW/A,SJ/A,SJC1/A,SJC5/A,SJG/A,SMS/A,SNR/A,STP/A,STQ/A,VAH1/A,VH/A,VS1/A,VS3/A,VX/A,VXE/A,VXEB/A,VXU/A,WJ/A,WKM,W1/A
			1	-	-	EDT3,ES2,VS4



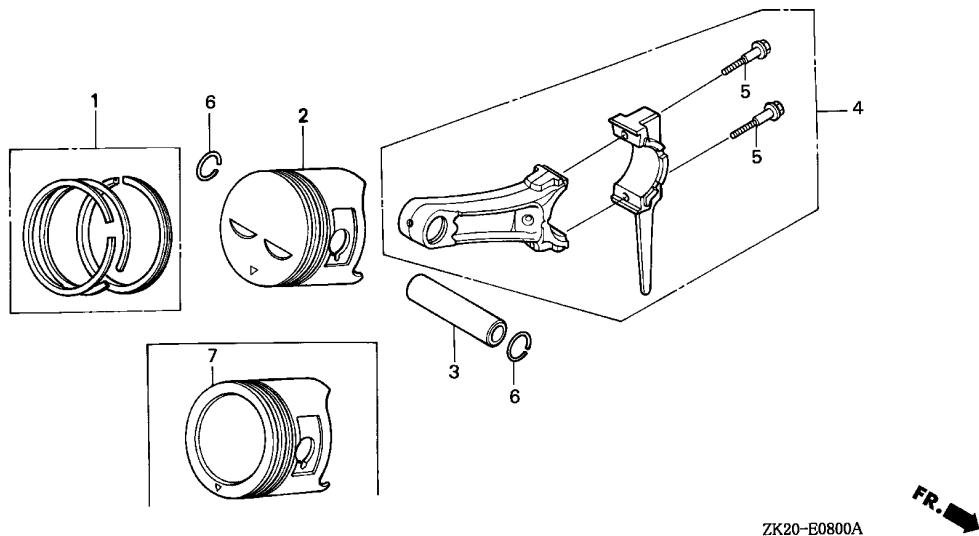

2

Ref. No.	Part No.	Description	Reqd. QTY			Serial No.	Parts catalogue code
			(1)	(2)	(3)		
(2)	13102-ZE2-W01	PISTON (0.25)	(1)	(1)	-	4869815	EDS1/A,EDT1/A,ED5/A,ES1/A,ES3/A,HX/A,LH/A,LJ/A,LJG/A,LJS/A,LKS/A,LP/A,LSX/A,LT/A,LX/A,LXF,L1/A,PX/A,QD/A,QH/A,QHP1/A,QMH/A,QP/A,QX/A,QXC/A,QXE/A,Q1/A,RD/A,RJ/A,RSS1/A,RX/A,R1/A,SD/A,SDB3/A,SHW/A,SJ/A,SJC1/A,SJC5/A,SJG/A,SMS/A,SNR/A,STP/A,SX/A,S1/A,VH/A,VS1/A,VS3,VX/A,VXE/A,VXEB/A,VXU/A,WJ/A,WMK,W1/A
	13103-ZE2-W01	PISTON (0.50)	(1)	-	-	4869815	EDT3,ES2,VS4
	13104-ZE2-W01	PISTON (0.75)	(1)	(1)	-	4869815	EDS1/A,EDT1/A,ED5/A,ES1/A,ES3/A,HX/A,LH/A,LJ/A,LJG/A,LJS/A,LKS/A,LP/A,LSX/A,LT/A,LX/A,LXF,L1/A,PX/A,QD/A,QH/A,QHP1/A,QMH/A,QP/A,QX/A,QXC/A,QXE/A,Q1/A,RD/A,RJ/A,RSS1/A,RX/A,R1/A,SD/A,SDB3/A,SHW/A,SJ/A,SJC1/A,SJC5/A,SJG/A,SMS/A,SNR/A,STP/A,SX/A,S1/A,VH/A,VS1/A,VS3,VX/A,VXE/A,VXEB/A,VXU/A,WJ/A,WMK,W1/A
3	13111-ZE2-000	PIN, PISTON	1	1	1		EDT3,ES2,VS4
4	13200-ZE2-010	ROD ASSY., CONNECTING (STD.)	1	1	1		

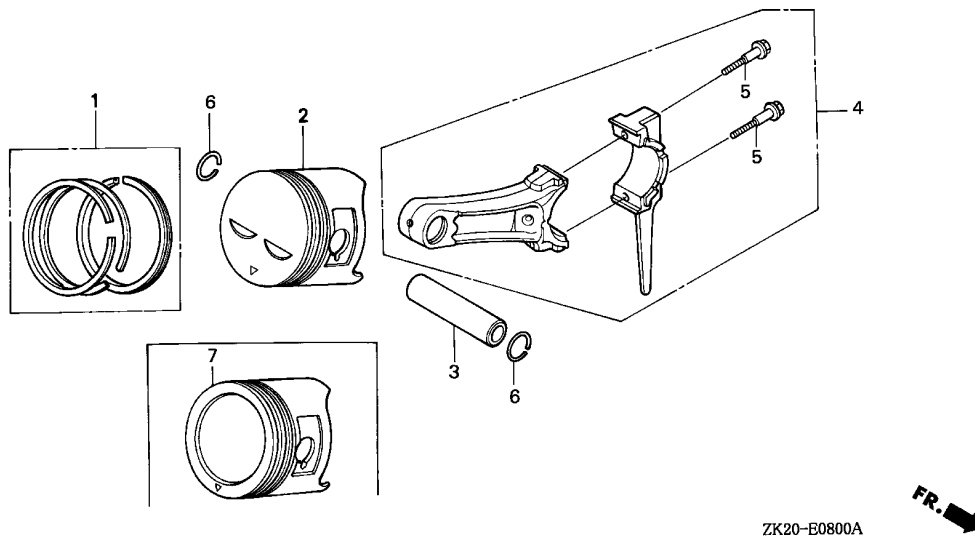

Ref. No.	Part No.	Description	Reqd. QTY GX240K1 (1) (2) (3)	Serial No.	Parts catalogue code
(4)	13200-ZE2-305	ROD ASSY., CONNECTING (0.25 UNDER SIZE)	(1) - -	-----	EDN,EDN2,EDS,EDS1,EDS2,EDS3,EDS5,EDS6,EDT1,EDT2,EDT3,EDT6,ED2,ED3 ED4,ED4/A,ED5,ED5/A,EN,EN2,ES,ES1,ES1/A,ES2,ES3,ET,ETS,ETX,HA,HAQ HA2,HA2/A,HH,HHQ4,HHQ4/A,HTX,HX,HX/A,HXQ4,HXQ4/A,LD,LDB1,LDB3,LH LH/A,LHE,LHE4,LHE4/A,LHZ,LJ,LJ/A,LJG,LJG/A,LJG1,LJS,LJS/A,LK,LKS LM9,LNJ,LNZ,LP,LP/A,LSS4,LSS5,LSS5/A,LSX,LSX/A,LT,LT/A,LW,LX,LX/A LXF,LXQ4,LXQ4/A,LXZ,LX2,LX2/A,PA,PAE,PA2,PA2/A,PMT2,PMT2/A,PX PX/A,QA,QAB2,QAB2/A,QAE,QAE2,QAE2/A,QAG,QAG/A,QAG2,QAG2/A,QAQ QAQ4,QAR2,QAR2/A,QA2,QA2/A,QC12,QC12/A,QD,QD/A,QDA,QE,QE/A,QH QH/A,QHB2,QHC,QHE,QHP1,QHP1/A,QHQ4,QHQ4/A,QHZ,QKA2,QMH,QMH/A,QMX2 QP,QP/A,QT,QT/A,QTC2,QTC2/A,QW24,QX,QX/A,QXB,QXB7,QXB7/A,QXC QXC/A,QXC9,QXC9/A,QXE,QXE/A,QXEB,QXE4,QXE4/A,QXQ4,QXQ4/A,QXU QXU/A,RA,RA2,RA2/A,RD,RD/A,RH,RHE,RHE4,RHQ4,RHQ4/A,RJ,RJ/A,RSC2 RSS1,RSS1/A,RTB2,RTB2/A,RX,RX/A,RXQ4,RXQ4/A,SD,SD/A,SDB1,SDB3 SDB3/A,SE,SE/A,SH,SHE,SHEZ,SHW,SHW/A,SJ,SJ/A,SJC,SJC1,SJC1/A,SJC5 SJC5/A,SJG,SJG/A,SJP,SK,SMS,SMS/A,SMX2,SMX2/A,SNC1,SNE1,SNR,SNR/A STP,STP/A,STQ,STQ/A,SW,SWE,SX,SX/A,SBX,SXE,SXEB,SXE4,SXE4/A,SXQ4 SXQ4/A,SXU,SXU/A,VA,VAH1,VA2,VA2/A,VDG2,VDG2/A,VH,VH/A,VH12 VH12/A,VMT2,VMX,VNG,VS1,VS3,VS4,VTA,VTA2,VTA2/A,VTE2,VWC2,VWC2/A VX,VX/A,VXB,VXB/A,VXB7,VXB7/A,VXE,VXE/A,VXEB,VXEB/A,VXQ4,VXQ4/A VXQ7,VXQ7/A,VXU,VXU/A,VXU1,VXU1/A,WH,WJ,WJ/A,WKA,WKD6,WKD6/A,WKT2 WKT2/A,WKT4,WKT4/A,WMK
	5 90001-ZE8-000	BOLT, CONNECTING ROD	- (1) (1) 2 2 2		
	6 90551-ZE1-000	CLIP, PISTON PIN, 18MM	2 2 2		
	7 13101-ZE2-811	PISTON (STD.)	1 - -	-----	QDA,QT,QT/A
	13102-ZE2-811	PISTON (0.25)	(1) - -	-----	QDA,QT,QT/A
	13103-ZE2-811	PISTON (0.50)	(1) - -	-----	QDA,QT,QT/A
	13104-ZE2-811	PISTON (0.75)	(1) - -	-----	QDA,QT,QT/A

E-9

CAMSHAFT

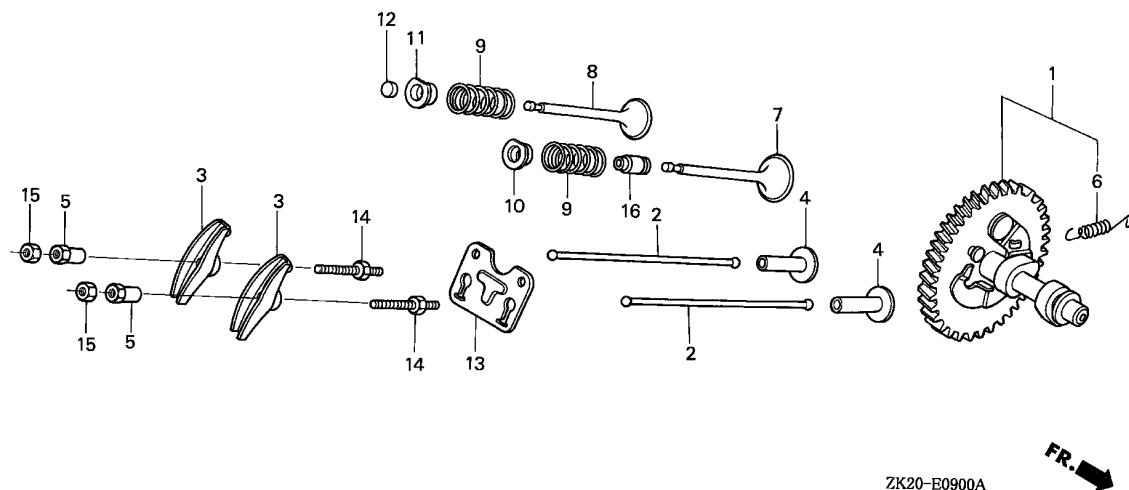

ZK20-E0900A

Ref. No.	L.O.N.	(Relative ref. Number) Description	F.R.T.
1	1111C2	CAMSHAFTINCLUDES: Valve clearance adjustment	0.4
2	1111L6	ROD, PUSH :INTAKEINCLUDES: Valve clearance adjustment	0.2
	1111L6A	.Replace exhaust push rod add	0.1
	1111L7	ROD, PUSH :EXHAUSTINCLUDES: Valve clearance adjustment	0.2
	1111L7A	.Replace intake push rod add	0.1
3	1111A2	ARM, ROCKER :INTAKEINCLUDES: Valve clearance adjustment	0.2
	1111A2A	.Replace exhaust rocker arm add	0.1
	1111A1	ARM, ROCKER :EXHAUSTINCLUDES: Valve clearance adjustment	0.2
	1111A1A	.Replace intake rocker arm add	0.1
4	1111L9	LIFTER, VALVE :INTAKEINCLUDES: Valve clearance adjustment	0.4
		.NOTE: Same time for two units	
+	1111M0	LIFTER, VALVE :EXHAUST	0.4

Ref. No.	Part No.	Description	Reqd. QTY			Serial No.	Parts catalogue code
			(1)	(2)	(3)		
1	14100-ZH9-000	CAMSHAFT ASSY.	1	1	-	3620888	EDN,EDS,EDS1,EDS3,EDS5,EDT1,ED3,ED4,ED5,EN,ES,ES1,ES3,ET,ETS,ETX,HA,HH,HHQ4,HTX,HX,HXQ4,LD,LDB1,LDB3,LH,LHE,LHE4,LHZ,LJ,LJG,LJG1,LK,LKS,LM9,LNJ,LNZ,LP,LSX,LW,LX,LXQ4,LXZ,L1,PA,PAE,PX,P1,QA,QAE,QAQ4,QD,QE,QH,QHC,QHE,QHP1,QHQ4,QHZ,QMH,QP,QT,QX,QXB,QXC,QXE,QXEB,QXE4,QXQ4,Q1,RA,RD,RH,RHE,RHE4,RHQ4,RJ,RX,RXQ4,R1,SD,SDB1,SDB3,SE,SH,SHE,SHEZ,SJ,SJC,SJC1,SJC5,SJG,SJP,SK,SMS,SNC1,SNE1,SNR,STP,STQ,SW,SWE,SX,SXB,SXE,SXEB,SXE4,SXQ4,S1,VA,VAH1,VH,VMX,VNG,VSB1,VTA,VX,VXB,VXE,VXEB,VXQ4,VXU,V1,WH,WJ,WKA,W1
			1	-	-	-----	QDA
			1	-	-	-----	3337056 ED2
			-	-	1	-----	1000025 VXP,VXQP
	14100-ZE2-W00	1	-	-	-----	3620688 EDN2,EDS2,EDT2,HAQ,HA2,LX2,PA2,PMT2,QAE2,QAG2,QAQ,QAR2,QA2,QKA2,QXC9,RA2,RSC2,RTB2,SMX2,VA2,VH12,VTE2,VWC2,WKT2
			1	-	-	3337057	3620688 ED2
	14100-ZH9-010	1	1	1	-----	ES1/A,ES2,LJ/A,LJG/A,LKS/A,LP/A,LSS4,LSS5,LSS5/A,LT,LT/A,L1/A,QD/A,QE/A,QP/A,QT/A,Q1/A,RD/A,RJ/A,RSS1,RSS1/A,R1/A,SD/A,SDB3/A,SE/A,SHW,SHW/A,SJ/A,SJC1/A,SJC5/A,SJG/A,SMS/A,S1/A,VXP/A,WJ/A,WMK,W1/A
			1	1	-	3620889	----- EDS,EDS5,EN,ES,ES1,ET,ETS,ETX,HA,HH,HTX,LD,LDB1,LDB3,LJ,LJG,LJG1,LK,LKS,LM9,LNJ,LNZ,LP,LW,LXZ,L1,PA,PAE,P1,QA,QAE,QD,QE,QHC,QHE,QP,QT,QXB,QXEB,Q1,RA,RD,RH,RHE,RHE4,RJ,R1,SD,SDB1,SDB3,SE,SH,SHEZ,SJ,SJC,SJC1,SJC5,SJG,SJP,SK,SMS,SNC1,SNE1,SW,SWE,SXB,SXE,SXEB,S1,VA,VAH1,VNG,VTA,V1,WH,WJ,WKA,W1
			1	-	-	-----	3860624 QXU,SXU,VXU1
			1	-	-	3620889	3860624 EDN,EDS1,EDS3,EDT1,ED3,ED4,ED5,ES3,HHQ4,HX,HXQ4,LH,LHE,LHE4,LHZ,LSX,LX,LXQ4,PX,QAQ4,QH,QHP1,QHQ4,QHZ,QMH,QX,QXC,QXE,QXE4,QXQ4,RHQ4,RX,RXQ4,SHE,SNR,STP,STQ,SX,SXE4,SXQ4,VH,VMX,VSB1,VX,VXB,VXE,VXEB,VXQ4,VXU
			-	-	1	1000026	----- VXP,VXQP

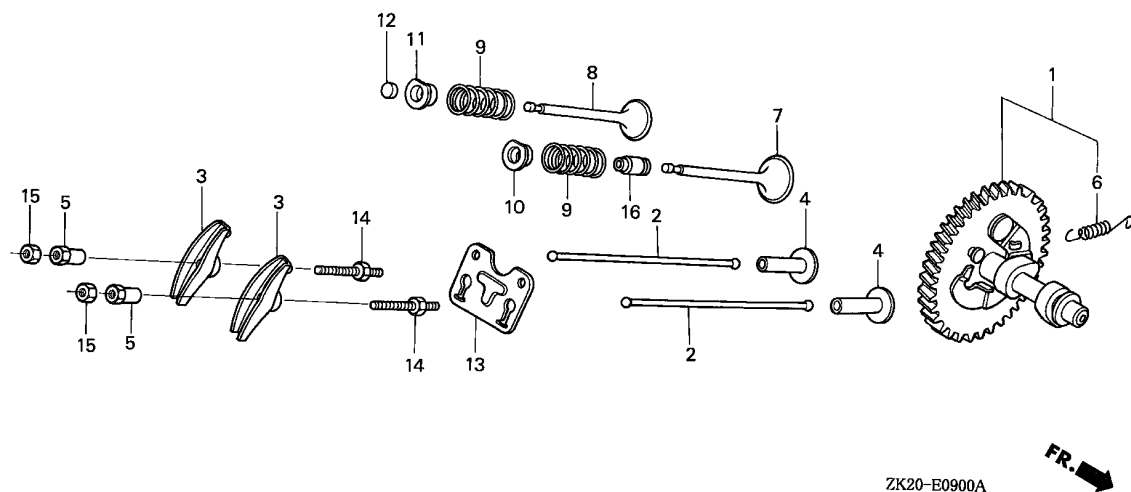

ZK20-E0900A

Ref. No.	L.O.N.	(Relative ref. Number) Description	F.R.T.
+ 4		.INCLUDES: Valve clearance adjustment .NOTE: Same time for two units	
7	1111L1	VALVE, INTAKE	0.7
	1111L1E	.INCLUDES: Valve clearance adjustment and reface .Replace intake and exhaust all add	0.1
8	1111L0	VALVE, EXHAUST	0.7
	1111L0E	.INCLUDES: Valve clearance adjustment and reface .Replace intake and exhaust all add	0.1
9	1111P3	SPRING, VALVE :INTAKE	0.6
	1111P3A	.INCLUDES: Valve clearance adjustment .Replace intake and exhaust all add	0.1
	1111P4	SPRING, VALVE :EXHAUST	0.6
	1111P4A	.INCLUDES: Valve clearance adjustment .Replace intake and exhaust all add	0.1
+12	1111J7	ROTATOR, VALVE	0.2

Ref. No.	Part No.	Description	Reqd. QTY			Serial No.	Parts catalogue code
			(1)	(2)	(3)		
(1)	14100-ZE2-W01	CAMSHAFT ASSY.	1	-	-	-----	EDN2/A,EDS1/A,EDS2/A,EDS6,EDS6/A,EDT1/A,EDT3,EDT6,EDT6/A,ED2/A,ED4/A,ED5/A,EN2,EN2/A,ES3/A,HA2/A,HHQ4/A,HX/A,HXQ4/A,LH/A,LHE4/A,LJS,LJS/A,LSX/A,LX/A,LXF,LXQ4/A,LX2/A,PA2/A,PMT2/A,PX/A,QAB2,QAB2/A,QAE2/A,QAG,QAG/A,QAG2/A,QAR2/A,QA2/A,QC12,QC12/A,QH/A,QHB2,QHP1/A,QHQ4/A,QMH/A,QMX2,QTC2,QTC2/A,QW24,QX/A,QXC/A,QXC9/A,QXE/A,QXE4/A,QXQ4/A,QXU/A,RA2/A,RHQ4/A,RTB2/A,RX/A,RXQ4/A,SMX2/A,SNR/A,STP/A,STQ/A,SX/A,SXE4/A,SXQ4/A,SXU/A,VA2/A,VDG2,VDG2/A,VH/A,VH12/A,VMT2,VSB1/A,VS3,VS4,VTA2,VTA2/A,VWC2/A,VX/A,VXB/A,VXE/A,VXEB/A,VXQ4/A,VXU/A,VXU1/A,WKD6,WKD6/A,WKT2/A,WKT4,WKT4/A
			1	-	-	3620689	EDN2,EDS2,EDT2,ED2,HAQ,HA2,LX2,PA2,PMT2,QAE2,QAG2,QAQ,QAR2,QA2
			1	-	-	3860625	EDN,EDS1,EDS3,EDT1,ED3,ED4,ED5,ES3,HHQ4,HX,HXQ4,LH,LHE,LHE4,LHZ,LSX,LX,LXQ4,PX,QAQ4,QH,QHP1,QHQ4,QHZ,QMH,QX,QXC,QXE,QXE4,QXQ4,QXU,RHQ4,RX,RXQ4,SHE,SNR,STP,STQ,SX,SXE4,SXQ4,SXU,VH,VMX,VSB1,VX,VXB,VXE,VXEB,VXQ4,VXU,VXU1
	14100-ZK2-870	1	-	-	-----	QXB7,QXB7/A,VXB7,VXB7/A,VXQ7,VXQ7/A
	2 14410-ZE2-013	ROD, PUSH	2	2	2	-----	
	3 14431-ZE2-000	ARM, VALVE ROCKER	2	-	-	-----	EDS,EN,ET,ETS,ETX,HA,HAQ,HH,LDB1,LW,LXZ,PA,PAE,QA,QAE,QAQ,QDA,QHC,QHE,QKA2,QXB,QXEB,RA,RH,RHE,RHE4,SH,SHEZ,SNC1,SNE1,SW,SWE,SXB,SXE,SXEB,VA,VAH1,VNG,VTA,VTE2,WH



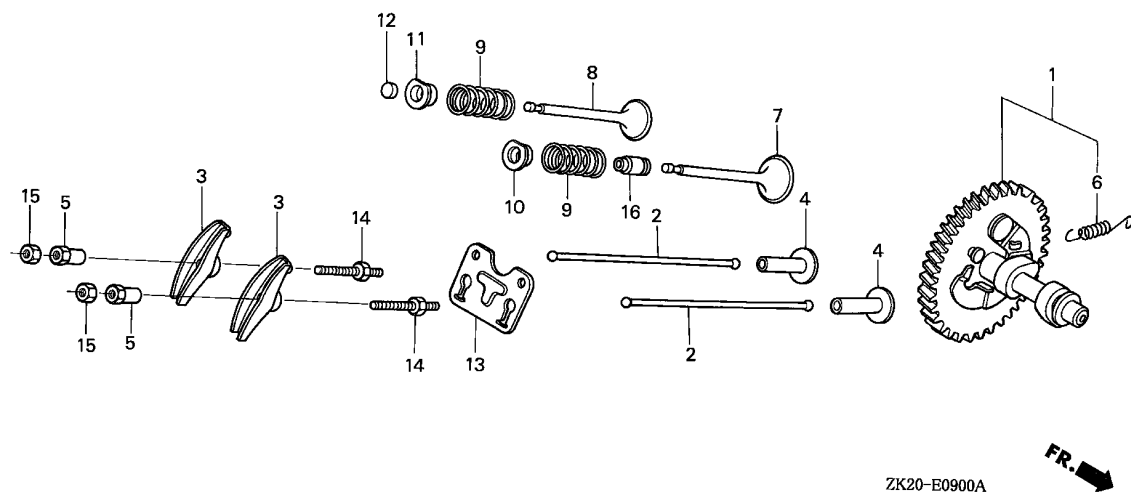

Ref. No.	L.O.N.	(Relative ref. Number) Description	F.R.T.
+12		.INCLUDES: Valve clearance adjustment	
16	1111K2	SEAL, INTAKE VALVE STEMINCLUDES: Valve clearance adjustment	0.6

ZK20-E0900A

Ref. No.	Part No.	Description	Reqd. QTY			Serial No.	Parts catalogue code
			(1)	(2)	(3)		
(3)	14431-ZE2-010	ARM, VALVE ROCKER	2	-	-	-----	EDN,EDN2,EDN2/A,EDS1,EDS1/A,EDS2,EDS2/A,EDS3,EDS5,EDS6,EDS6/A,EDT1,EDT1/A,EDT2,EDT3,EDT6,EDT6/A,ED2,ED2/A,ED3,ED4,ED4/A,ED5,ED5/A,EN2,EN2/A,ES,ES1,ES1/A,ES2,ES3,ES3/A,HA2,HA2/A,HHQ4,HHQ4/A,HTX,HX,HX/A,HXQ4,HXQ4/A,LD,LDB3,LH,LH/A,LHE,LHE4,LHE4/A,LHZ,LJ,LJ/A,LJG,LJG/A,LJG1,LJS,LJS/A,LK,LKS,LKS/A,LM9,LNJ,LNZ,LP,LP/A,LSS4,LSS5,LSS5/A,LSX,LSX/A,LT,LT/A,LX,LX/A,LXF,LXQ4,LXQ4/A,LX2,LX2/A,PA2,PA2/A,PMT2,PMT2/A,PX,PX/A,QAB2,QAB2/A,QAE2,QAE2/A,QAG,QAG/A,QAG2,QAG2/A,QAQ4,QAR2,QAR2/A,QA2,QA2/A,QC12,QC12/A,QD,QD/A,QE,QE/A,QH,QH/A,QHB2,QHP1,QHP1/A,QHQ4,QHQ4/A,QHZ,QMH,QMH/A,QMX2,QP,QP/A,QT,QT/A,QTC2,QTC2/A,QW24,QX,QX/A,QXB7,QXB7/A,QXC,QXC/A,QXC9,QXC9/A,QXE,QXE/A,QXE4,QXE4/A,QXQ4,QXQ4/A,QXU,QXU/A,RA2,RA2/A,RD,RD/A,RHQ4,RHQ4/A,RJ,RJ/A,RSC2,RSS1,RSS1/A,RTB2,RTB2/A,RX,RX/A,RXQ4,RXQ4/A,SD,SD/A,SDB1,SDB3,SDB3/A,SE,SE/A,SHE,SHW,SHW/A,SJ,SJ/A,SJC,SJC1,SJC1/A,SJC5,SJC5/A,SJG,SJG/A,SJP,SK,SMS,SMS/A,SMX2,SMX2/A,SNR,SNR/A,STP,STP/A,STQ,STQ/A,SX,SX/A,SXE4,SXE4/A,SXQ4,SXQ4/A,SXU,SXU/A,VA2,VA2/A,VDG2,VDG2/A,VH,VH/A,VH12,VH12/A,VMT2,VMX,VSB1,VSB1/A,VS3,VS4,VTA2,VTA2/A,VWC2,VWC2/A,VX,VX/A,VXB,VXB/A,VXB7,VXB7/A,VXE,VXE/A,VXEB,VXEB/A,VXQ4,VXQ4/A,VXQ7,VXQ7/A,VXU,VXU/A,VXU1,VXU1/A,WJ,WJ/A,WKA,WKD6,WKD6/A,WKT2,WKT2/A,WKT4,WKT4/A,WMK
4	14441-ZE2-000	LIFTER, VALVE	-	2	2		
5	14451-ZE1-013	PIVOT, ROCKER ARM	2	2	2		
6	14568-ZE1-000	SPRING, WEIGHT RETURN	1	1	1		
7	14711-ZE2-000	VALVE, IN.	1	1	-		
	14711-ZE2-W00	-	-	1		
8	14721-ZE2-000	VALVE, EX.	1	(1)	-		

2

Ref. No.	Part No.	Description	Reqd. QTY			Serial No.	Parts catalogue code	
			(1)	(2)	(3)			
(8)	14721-ZE2-810	VALVE, EX. (STELLITE)	-	1	-	-----	L1,L1/A,Q1,Q1/A,R1,R1/A,S1,S1/A,W1,W1/A	
	14721-ZE2-W00	-	(1)	-	-----	P1,V1	
9	14751-ZE2-003	SPRING, VALVE	2	2	2			
10	14771-ZE2-000	RETAINER, IN. VALVE SPRING ..	1	1	1			
11	14773-ZE2-000	RETAINER, EX. VALVE SPRING ..	1	1	-			
	14771-ZE2-000	RETAINER, IN. VALVE SPRING ..	-	-	1			
12	14781-ZE2-000	ROTATOR, VALVE	1	1	-			
13	14791-ZE2-010	PLATE, PUSH ROD GUIDE	1	1	1			
14	90012-ZE0-010	BOLT, PIVOT, 8MM	2	2	2			
15	90206-ZE1-000	NUT, PIVOT ADJUSTING	2	2	2			
16	12209-ZE8-003	SEAL, VALVE STEM	1	1	-	-----	EDN2/A,EDS1/A,EDS2/A,EDS6,EDS6/A,EDT1/A,EDT3,EDT6,EDT6/A,ED2/A,ED4/A,ED5/A,EN2,EN2/A,ES1/A,ES2,ES3/A,HA2/A,HHQ4/A,HX/A,HXQ4/A,LH/A,LHE4/A,LJ/A,LJG/A,LJS,LJS/A,LKS/A,LP/A,LSS5/A,LSX/A,LT/A,LX/A,LXF,LXQ4/A,LX2/A,L1/A,PA2/A,PMT2/A,PX/A,QAB2/A,QAE2/A,QAG,QAG/A,QAG2/A,QAR2/A,QA2/A,QC12/A,QD/A,QE/A,QH/A,QHB2,QHP1/A,QHQ4/A,QMH/A,QP/A,QT/A,QTC2/A,QW24,QX/A,QXB7,QXB7/A,QXC/A,QXC9/A,QXE/A,QXE4/A,QXQ4/A,QXU/A,Q1/A,RA2/A,RD/A,RHQ4/A,RJ/A,RSS1/A,RTB2/A,RX/A,RXQ4/A,R1/A,SD/A,SDB3/A,SE/A,SHW,SHW/A,SJ/A,SJC1/A,SJC5/A,SJG/A,SMS/A,SMX2/A,SNR/A,STP/A,STQ/A,SX/A,SXE4/A,SXQ4/A,SXU/A,S1/A,VA2/A,VDG2/A,VH/A,VH12/A,VMT2,VSB1/A,VS3,VS4,VTA2/A,VWC2/A,VX/A,VXB/A,VXB7,VXB7/A,VXE/A,VXEB/A,VXQ4/A,VXQ7/A,VXU/A,VXU1/A,WJ/A,WKD6,WKD6/A,WKT2/A,WKT4/A,WMK,W1/A	
			1	1	-	4081305	-----	EDN2,EDS1,EDS2,EDT1,ED2,ED4,ED5,ES1,ES3,HA2,HHQ4,HX,HXQ4,LH,LHE4,LJ,LJG,LKS,LNZ,LP,LSS5,LSX,LT,LX,LXQ4,LX2,L1,PA2,PMT2,PX,QAB2,QAE2,QAG2,QAR2,QA2,QC12,QD,QE,QH,QHP1,QHQ4,QMH,QP,QT,QTC2,QX,QXC,QXC9,QXE,QXE4,QXQ4,QXU,Q1,RA2,RD,RHQ4,RJ,RSC2,RSS1,RTB2,RX,RXQ4,R1,SD,SDB3,SE,SJ,SJC1,SJC5,SJG,SMS,SMX2,SNR,STP,STQ,SX,SXE4,SXQ4,SXU,S1,VA2,VDG2,VH,VH12,VMX,VSB1,VTA2,VWC2,VX,VXB,VXE,VXEB,VXQ4,VXU,VXU1,WJ,WKT2,WKT4,W1
			-	-	1			



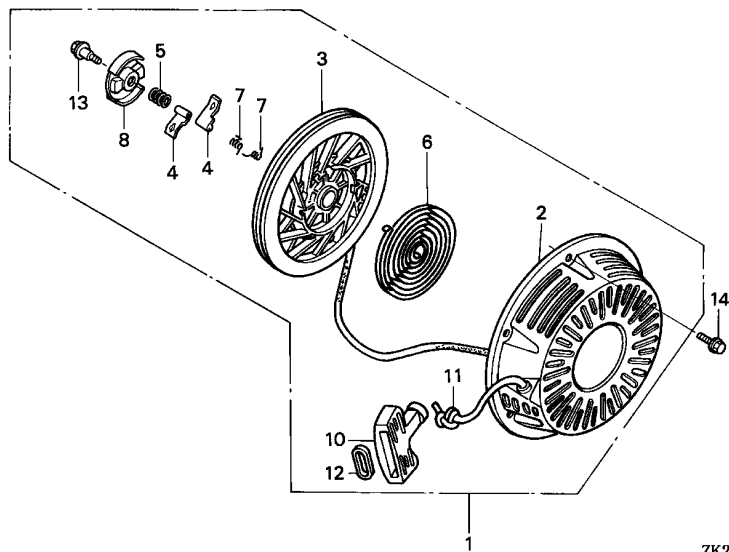

ZK20-E1100A

Ref. No.	L.O.N.	(Relative ref. Number) Description	F.R.T.
1	1121B9	STARTER, RECOIL	0.1
3	1121B1	REEL, RECOIL STARTER	0.3
4	1121B0	RATCHET, STARTER AND/OR SPRING, RATCHET	0.2
.NOTE: Same time for two units			
6	1121B7	SPRING, RECOIL STARTER RETURN (5)	0.3
8	1121B2	RETAINER, SPRING	0.2
11	1121B3	ROPE, RECOIL STARTER	0.3

Ref. No.	Part No.	Description	Reqd. QTY			Serial No.	Parts catalogue code
			(1)	(2)	(3)		
1	28400-ZE2-W01ZA	STARTER ASSY., RECOIL *R8*.....BRIGHT RED	1	(1)	-	-----	EDS,EDS1,EDS3,EDT1,ED2,ED3,ED4,ED5,EN,ES,ES1,ES3,ET,ETS,ETX,HA HAQ,HA2,HH,HHQ4,HTX,HX,HXQ4,LD,LDB1,LDB3,LH,LHE,LHE4,LHZ,LJ,LJG LJG1,LJS,LK,LNZ,LP,LSS4,LSS5,LSX,LT,LW,LX,LXQ4,LXZ,LX2,L1,PA,PAE PA2,PX,P1,QA,QAB2,QAE,QAE2,QAG,QAG2,QAQ,QAQ4,QAR2,QA2,QC12,QD,QDA QE,QH,QHC,QHE,QHP1,QHQ4,QHZ,QKA2,QMH,QMX2,QP,QT,QTC2,QX,QXB,QXB7 QXC,QXC9,QXE,QXEB,QXE4,QXQ4,QXU,Q1,RA,RA2,RD,RH,RHE,RHE4,RHQ4,RJ RSC2,RSS1,RTB2,RX,RXQ4,R1,SD,SDB1,SDB3,SE,SH,SHE,SHEZ,SJ,SJC,SJC1 SJC5,SJG,SJP,SK,SMS,SMX2,SNC1,SNE1,SNR,STP,STQ,SW,SWE,SX,SXB,SXE SXEB,SXE4,SXQ4,SXU,S1,VA,VAH1,VA2,VDG2,VH,VH12,VMX,VNG,VSB1,VTA VTA2,VX,VXB,VXB7,VXE,VXEB,VXQ4,VXQ7,VXU,VXU1,V1,WH,WJ,WKA,WKD6 WKT2,WKT4,W1
			1	(1)	-	4465232	EDS1/A,EDT1/A,ED2/A,ED4/A,ED5/A,ES1/A,ES3/A,HA2/A,HHQ4/A,HX/A HXQ4/A,LH/A,LHE4/A,LJ/A,LJG/A,LJS/A,LP/A,LSS5/A,LSX/A,LT/A,LX/A LXQ4/A,LX2/A,L1/A,PA2/A,PX/A,QAB2/A,QAE2/A,QAG/A,QAG2/A,QAR2/A QA2/A,QC12/A,QD/A,QE/A,QH/A,QHP1/A,QHQ4/A,QMH/A,QP/A,QT/A,QTC2/A QX/A,QXB7/A,QXC/A,QXC9/A,QXE/A,QXE4/A,QXQ4/A,QXU/A,Q1/A,RA2/A RD/A,RHQ4/A,RJ/A,RSS1/A,RTB2/A,RX/A,RXQ4/A,R1/A,SD/A,SDB3/A,SE/A SJ/A,SJC1/A,SJC5/A,SJG/A,SMS/A,SMX2/A,SNR/A,STP/A,STQ/A,SX/A SXE4/A,SXQ4/A,SXU/A,S1/A,VA2/A,VDG2/A,VH/A,VH12/A,VSB1/A,VTA2/A VX/A,VXB/A,VXB7/A,VXE/A,VXEB/A,VXQ4/A,VXQ7/A,VXU/A,VXU1/A,WJ/A WKD6/A,WKT2/A,WKT4/A,W1/A
			-	-	1		

Ref. No.	Part No.	Description	Reqd. QTY			Serial No.	Parts catalogue code
			(1)	(2)	(3)		
(1)	28400-ZE2-W01ZN	STARTER ASSY., RECOIL *R280*.....POWER RED	1	(1)	-	4465233	----- EDS1/A,EDT1/A,ED2/A,ED4/A,ED5/A,ES1/A,ES3/A,HA2/A,HHQ4/A,HX/A HXQ4/A,LH/A,LHE4/A,LJ/A,LJG/A,LJS/A,LP/A,LSS5/A,LSX/A,LT/A,LX/A LXQ4/A,LX2/A,L1/A,PA2/A,PX/A,QAB2/A,QAE2/A,QAG/A,QAG2/A,QAR2/A QA2/A,QC12/A,QD/A,QE/A,QH/A,QHP1/A,QHQ4/A,QMH/A,QP/A,QT/A,QTC2/A QX/A,QXB7/A,QXC/A,QXC9/A,QXE/A,QXE4/A,QXQ4/A,QXU/A,Q1/A,RA2/A RD/A,RHQ4/A,RJ/A,RSS1/A,RTB2/A,RX/A,RXQ4/A,R1/A,SD/A,SDB3/A,SE/A SJ/A,SJC1/A,SJC5/A,SJG/A,SMS/A,SMX2/A,SNR/A,STP/A,STQ/A,SX/A SXE4/A,SXQ4/A,SXU/A,S1/A,VA2/A,VDG2/A,VH/A,VH12/A,VSB1/A,VTA2/A VX/A,VXB/A,VXB7/A,VXE/A,VXEB/A,VXQ4/A,VXQ7/A,VXU/A,VXU1/A,WJ/A WKD6/A,WKT2/A,WKT4/A,W1/A
	28400-ZE2-W01ZB	*NH1*.....BLACK	1	-	1	-----	EDT3,ES2,LXF,QHB2,VS3,VXP/A,WMK EDN,EDN2,EDN2/A,EDS1,EDS1/A,EDS2,EDS2/A,EDS3,EDS6,EDS6/A,EDT1 EDT1/A,EDT2,EDT3,EDT6,EDT6/A,ED2,ED2/A,ED4,ED4/A,ED5,ED5/A,EN2 EN2/A,ES1,ES1/A,ES2,ES3,ES3/A,HA2,HA2/A,LX2,LX2/A,PA2,PA2/A,PMT2/A PMT2/A,PX,PX/A,QAE2,QAE2/A,QAG,QAG/A,QAQ4,QAR2,QAR2/A,QA2,QA2/A QMX2,QTC2,QTC2/A,QW24,QXC9,QXC9/A,Q1,Q1/A,RA2,RA2/A,SMX2,SMX2/A SX,SX/A,SXU,SXU/A,S1,S1/A,VA2,VA2/A,VS3,VTA2,VTA2/A,VVC2,VVC2/A VXB7,VXB7/A,VXQ4,VXQ4/A
	28400-ZE2-W01ZD	*T41*...BARTELL BLUE METALLIC	1	-	-	3139635	----- HA,QA 3187181 ----- HAQ,QAQ ----- QAQ4 3139635 ----- QA
	28400-ZE2-W01ZG	*NH105*...MAT BLACK (#15-#20)	1	-	-	-----	VMT2,VS3,VVC2,VVC2/A,VXB7,VXB7/A
	28400-ZE2-W01ZJ	*T68*.....TSURUMI BLUE	1	-	-	-----	ED2,ED2/A,VTE2
	28400-ZE2-W01ZK	*Y131*.....LIGHTNING YELLOW	1	-	-	-----	ED2,ED2/A,ES1,ES1/A,ES2,ES3,ES3/A,VTE2
	28400-ZE2-W01ZL	*T77*.....SEC WINE RED	1	-	-	-----	ES1,ES1/A,ES2,ES3,ES3/A
	28400-ZE2-W01ZM	*T80*.....BAKELITE ORANGE	1	-	-	-----	ED2,ED2/A,ES1,ES1/A,ES2,ES3,ES3/A
2	28410-ZE2-W01ZA	CASE COMP., RECOIL STARTER *R8*.....BRIGHT RED	1	(1)	-	-----	EDS,EDS1,EDS3,EDT1,ED2,ED3,ED4,ED5,EN,ES,ES1,ES3,ET,ETS,ETX,HA HAQ,HA2,HH,HHQ4,HTX,HX,HXQ4,LD,LDB1,LDB3,LH,LHE,LHE4,LHZ,LJ,LJG LJG1,LJS,LK,LNZ,LP,LSS4,LSS5,LSX,LT,LW,LX,LXQ4,LXZ,LX2,L1,PA,PAE PA2,PX,P1,QA,QAB2,QAE,QAE2,QAG,QAG2,QAQ,QAQ4,QAR2,QA2,QC12,QD,QDA QE,QH,QHC,QHE,QHP1,QHQ4,QHZ,QKA2,QMH,QMX2,QP,QT,QTC2,QX,QXB,QXB7 QXC,QXC9,QXE,QXEB,QXE4,QXQ4,QXU,Q1,RA,RA2,RD,RH,RHE,RHE4,RHQ4,RJ RSC2,RSS1,RTB2,RX,RXQ4,R1,SD,SDB1,SDB3,SE,SH,SHE,SHEZ,SJ,SJC,SJC1 SJC5,SJG,SJP,SK,SMS,SMX2,SNC1,SNE1,SNR,STP,STQ,SW,SWE,SX, SXB,SXE SXE4,SXQ4,SXU,S1,VA,VAH1,VA2,VDG2,VH,VH12,VMX,VNG,VSB1,VTA VTA2,VX,VXB,VXB7,VXE,VXEB,VXQ4,VXQ7,VXU,VXU1,V1,WH,WJ,WKA,WKD6 WKT2,WKT4,W1
			1	(1)	-	4465232	----- EDS1/A,EDT1/A,ED2/A,ED4/A,ED5/A,ES1/A,ES3/A,HA2/A,HHQ4/A,HX/A HXQ4/A,LH/A,LHE4/A,LJ/A,LJG/A,LJS/A,LP/A,LSS5/A,LSX/A,LT/A,LX/A LXQ4/A,LX2/A,L1/A,PA2/A,PX/A,QAB2/A,QAE2/A,QAG/A,QAG2/A,QAR2/A QA2/A,QC12/A,QD/A,QE/A,QH/A,QHP1/A,QHQ4/A,QMH/A,QP/A,QT/A,QTC2/A QX/A,QXB7/A,QXC/A,QXC9/A,QXE/A,QXE4/A,QXQ4/A,QXU/A,Q1/A,RA2/A RD/A,RHQ4/A,RJ/A,RSS1/A,RTB2/A,RX/A,RXQ4/A,R1/A,SD/A,SDB3/A,SE/A SJ/A,SJC1/A,SJC5/A,SJG/A,SMS/A,SMX2/A,SNR/A,STP/A,STQ/A,SX/A SXE4/A,SXQ4/A,SXU/A,S1/A,VA2/A,VDG2/A,VH/A,VH12/A,VSB1/A,VTA2/A VX/A,VXB/A,VXB7/A,VXE/A,VXEB/A,VXQ4/A,VXQ7/A,VXU/A,VXU1/A,WJ/A WKD6/A,WKT2/A,WKT4/A,W1/A
			-	-	1		



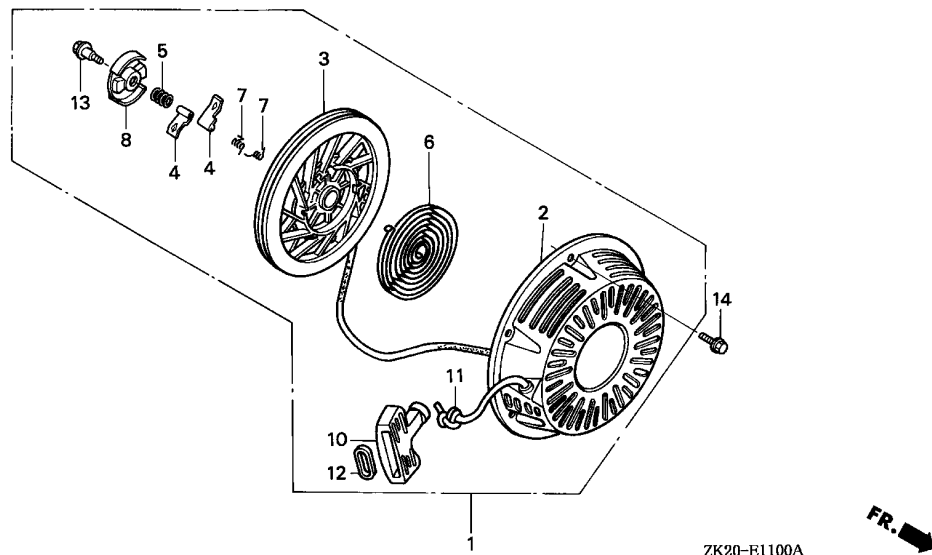

ZK20-E1100A

Ref. No.	Part No.	Description	Reqd. QTY			Serial No.	Parts catalogue code
			(1)	(2)	(3)		
(2)	28410-ZE2-W01ZN	CASE COMP., RECOIL STARTER *R280*.....POWER RED	1	(1)	-	4465233	----- EDS1/A,EDT1/A,ED2/A,ED4/A,ED5/A,ES1/A,ES3/A,HA2/A,HHQ4/A,HX/A HXQ4/A,LH/A,LHE4/A,LJ/A,LJG/A,LJS/A,LP/A,LSS5/A,LSX/A,LT/A,LX/A LXQ4/A,LX2/A,L1/A,PA2/A,PX/A,QAB2/A,QAE2/A,QAG/A,QAG2/A,QAR2/A QA2/A,QC12/A,QD/A,QE/A,QH/A,QHP1/A,QHQ4/A,QMH/A,QP/A,QT/A,QTC2/A QX/A,QXB7/A,QXC/A,QXC9/A,QXE/A,QXE4/A,QXQ4/A,QXU/A,Q1/A,RA2/A RD/A,RHQ4/A,RJ/A,RSS1/A,RTB2/A,RX/A,RXQ4/A,R1/A,SD/A,SDB3/A,SE/A SJ/A,SJC1/A,SJC5/A,SJG/A,SMS/A,SMX2/A,SNR/A,STP/A,STQ/A,SX/A SXE4/A,SXQ4/A,SXU/A,S1/A,VA2/A,VDG2/A,VH/A,VH12/A,VSB1/A,VTA2/A VX/A,VXB/A,VXB7/A,VXE/A,VXEB/A,VXQ4/A,VXQ7/A,VXU/A,VXU1/A,WJ/A WKD6/A,WKT2/A,WKT4/A,W1/A
	28410-ZE2-W01ZB	*NH1*.....BLACK	1	-	1	-----	EDT3,ES2,LXF,QHB2,VS3,VXP/A,WMK
	28410-ZE2-W01ZD	*T41*...BARTELL BLUE METALLIC	1	-	-	3139635	----- HA,QA
	28410-ZE2-W01ZG	*NH105*...MAT BLACK (#15-#20)	1	-	-	3187181	----- HAQ,QAQ
	28410-ZE2-W01ZJ	*T68*.....TSURUMI BLUE	1	-	-	3139635	----- QAQ4
	28410-ZE2-W01ZK	*Y131*.....LIGHTNING YELLOW	1	-	-	-----	QA
	28410-ZE2-W01ZL	*T77*.....SEC WINE RED	1	-	-	-----	VMT2,VS3,VWC2,VWC2/A,VXB7,VXB7/A
	28410-ZE2-W01ZM	*T80*.....BAKELITE ORANGE	1	-	-	-----	ED2,ED2/A,VTE2
			1	-	-	-----	ED2,ED2/A,ES1,ES1/A,ES2,ES3,ES3/A,VTE2
			1	-	-	-----	ES1,ES1/A,ES2,ES3,ES3/A
			1	-	-	-----	ED2,ED2/A,ES1,ES1/A,ES2,ES3,ES3/A

Ref. No.	Part No.	Description	Reqd. QTY			Serial No.	Parts catalogue code
			(1)	(2)	(3)		
3	28421-ZE2-W01	PULLEY, RECOIL STARTER	1	-	-	-----	EDN,EDN2,EDN2/A,EDS,EDS1,EDS1/A,EDS2,EDS2/A,EDS3,EDS6,EDS6/A,EDT1,EDT1/A,EDT2,EDT3,EDT6,EDT6/A,ED2,ED2/A,ED3,ED4,ED4/A,ED5,ED5/A,EN,EN2,EN2/A,ES,ES1,ES1/A,ES2,ES3,ES3/A,ET,ETS,ETX,HA,HAQ,HA2,HA2/A,HH,HHQ4,HHQ4/A,HTX,HX,HX/A,HXQ4,HXQ4/A,LD,LDB1,LDB3,LH,LH/A,LHE,LHE4,LHE4/A,LHZ,LJ,LJ/A,LJG,LJG/A,LJG1,LJS,LJS/A,LK,LNZ,LP,LP/A,LSS4,LSS5,LSS5/A,LSX,LSX/A,LT,LT/A,LW,LX,LX/A,LXF,LXQ4,LXQ4/A,LXZ,LX2,LX2/A,PA,PAE,PA2,PA2/A,PMT2,PMT2/A,PX,PX/A,QA,QAB2,QAB2/A,QAE,QAE2,QAE2/A,QAG,QAG/A,QAG2,QAG2/A,QAQ,QAQ4,QAR2,QAR2/A,QA2,QA2/A,QC12,QC12/A,QD,QD/A,QDA,QE,QE/A,QH,QH/A,QHB2,QHC,QHE,QHP1,QHP1/A,QHQ4,QHQ4/A,QHZ,QKA2,QMH,QMH/A,QMX2,QP,QP/A,QT,QT/A,QTC2,QTC2/A,QW24,QX,QX/A,QXB,QXB7,QXB7/A,QXC,QXC/A,QXC9,QXC9/A,QXE,QXE/A,QXEB,QXE4,QXE4/A,QXQ4,QXQ4/A,QXU,QXU/A,RA,RA2,RA2/A,RD,RD/A,RH,RHE,RHE4,RHQ4,RHQ4/A,RJ,RJ/A,RSC2,RSS1,RSS1/A,RTB2,RTB2/A,RX,RX/A,RXQ4,RXQ4/A,SD,SD/A,SDB1,SDB3,SDB3/A,SE,SE/A,SH,SHE,SHEZ,SJ,SJ/A,SJC,SJC1,SJC1/A,SJC5,SJC5/A,SJG,SJG/A,SJP,SK,SMS,SMS/A,SMX2,SMX2/A,SNC1,SNE1,SNR,SNR/A,STP,STP/A,STQ,STQ/A,SW,SWE,SX,SX/A,SBX,SXE,SXEB,SXE4,SXE4/A,SXQ4,SXQ4/A,SXU,SXU/A,VA,VAH1,VA2,VA2/A,VDG2,VDG2/A,VH,VH/A,VH12,VH12/A,VMT2,VMX,VNG,VSB1,VSB1/A,VS3,VS4,VTA,VTA2,VTA2/A,VTE2,VWC2,VWC2/A,VX,VX/A,VXB,VXB/A,VXB7,VXB7/A,VXE,VXE/A,VXEB,VXEB/A,VXQ4,VXQ4/A,VXQ7,VXQ7/A,VXU,VXU/A,VXU1,VXU1/A,WH,WJ,WJ/A,WKA,WKD6,WKD6/A,WKT2,WKT2/A,WKT4,WKT4/A,WMK
4	28422-ZE2-W01	RATCHET, STARTER	2	(1)	1	-----	EDN,EDN2,EDN2/A,EDS,EDS1,EDS1/A,EDS2,EDS2/A,EDS3,EDS6,EDS6/A,EDT1,EDT1/A,EDT2,EDT3,EDT6,EDT6/A,ED2,ED2/A,ED3,ED4,ED4/A,ED5,ED5/A,EN,EN2,EN2/A,ES,ES1,ES1/A,ES2,ES3,ES3/A,ET,ETS,ETX,HA,HAQ,HA2,HA2/A,HH,HHQ4,HHQ4/A,HTX,HX,HX/A,HXQ4,HXQ4/A,LD,LDB1,LDB3,LH,LH/A,LHE,LHE4,LHE4/A,LHZ,LJ,LJ/A,LJG,LJG/A,LJG1,LJS,LJS/A,LK,LNZ,LP,LP/A,LSS4,LSS5,LSS5/A,LSX,LSX/A,LT,LT/A,LW,LX,LX/A,LXF,LXQ4,LXQ4/A,LXZ,LX2,LX2/A,PA,PAE,PA2,PA2/A,PMT2,PMT2/A,PX,PX/A,QA,QAB2,QAB2/A,QAE,QAE2,QAE2/A,QAG,QAG/A,QAG2,QAG2/A,QAQ,QAQ4,QAR2,QAR2/A,QA2,QA2/A,QC12,QC12/A,QD,QD/A,QDA,QE,QE/A,QH,QH/A,QHB2,QHC,QHE,QHP1,QHP1/A,QHQ4,QHQ4/A,QHZ,QKA2,QMH,QMH/A,QMX2,QP,QP/A,QT,QT/A,QTC2,QTC2/A,QW24,QX,QX/A,QXB,QXB7,QXB7/A,QXC,QXC/A,QXC9,QXC9/A,QXE,QXE/A,QXEB,QXE4,QXE4/A,QXQ4,QXQ4/A,QXU,QXU/A,RA,RA2,RA2/A,RD,RD/A,RH,RHE,RHE4,RHQ4,RHQ4/A,RJ,RJ/A,RSC2,RSS1,RSS1/A,RTB2,RTB2/A,RX,RX/A,RXQ4,RXQ4/A,SD,SD/A,SDB1,SDB3,SDB3/A,SE,SE/A,SH,SHE,SHEZ,SJ,SJ/A,SJC,SJC1,SJC1/A,SJC5,SJC5/A,SJG,SJG/A,SJP,SK,SMS,SMS/A,SMX2,SMX2/A,SNC1,SNE1,SNR,SNR/A,STP,STP/A,STQ,STQ/A,SW,SWE,SX,SX/A,SBX,SXE,SXEB,SXE4,SXE4/A,SXQ4,SXQ4/A,SXU,SXU/A,VA,VAH1,VA2,VA2/A,VDG2,VDG2/A,VH,VH/A,VH12,VH12/A,VMT2,VMX,VNG,VSB1,VSB1/A,VS3,VS4,VTA,VTA2,VTA2/A,VTE2,VWC2,VWC2/A,VX,VX/A,VXB,VXB/A,VXB7,VXB7/A,VXE,VXE/A,VXEB,VXEB/A,VXQ4,VXQ4/A,VXQ7,VXQ7/A,VXU,VXU/A,VXU1,VXU1/A,WH,WJ,WJ/A,WKA,WKD6,WKD6/A,WKT2,WKT2/A,WKT4,WKT4/A,WMK



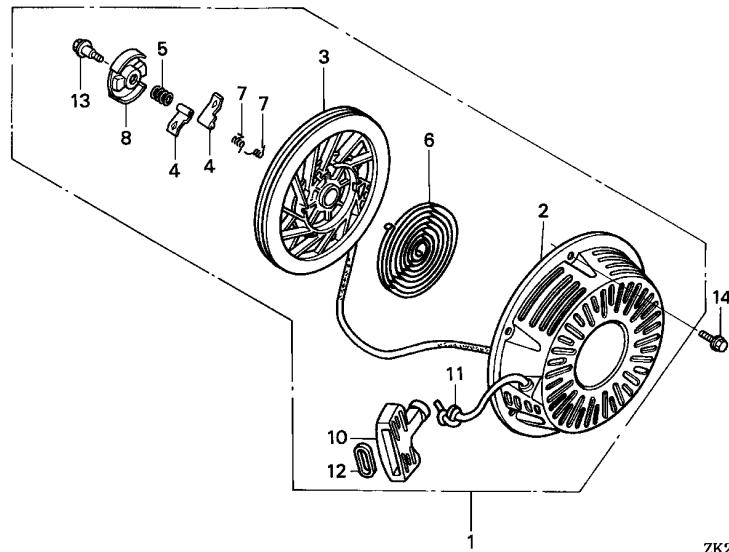

ZK20-E1100A



Ref. No.	Part No.	Description	Reqd. QTY			Serial No.	Parts catalogue code
			(1)	(2)	(3)		
5	28441-ZE2-W01	SPRING, FRICTION	1	-	-	-----	EDN,EDN2,EDN2/A,EDS,EDS1,EDS1/A,EDS2,EDS2/A,EDS3,EDS6,EDS6/A,EDT1,EDT1/A,EDT2,EDT3,EDT6,EDT6/A,ED2,ED2/A,ED3,ED4,ED4/A,ED5,ED5/A,EN,EN2,EN2/A,ES,ES1,ES1/A,ES2,ES3,ES3/A,ET,ETS,ETX,HA,HAQ,HA2,HA2/A,HH,HHQ4,HHQ4/A,HTX,HX,HX/A,HXQ4,HXQ4/A,LD,LDB1,LDB3,LH,LH/A,LHE,LHE4,LHE4/A,LHZ,LJ,LJ/A,LJG,LJG/A,LJG1,LJS,LJS/A,LK,LNZ,LP,LP/A,LSS4,LSS5,LSS5/A,LSX,LSX/A,LT,LT/A,LW,LX,LX/A,LXF,LXQ4,LXQ4/A,LXZ,LX2,LX2/A,PA,PAE,PA2,PA2/A,PMT2,PMT2/A,PX,PX/A,QA,QAB2,QAB2/A,QAE,QAE2,QAE2/A,QAG,QAG/A,QAG2,QAG2/A,QAQ,QAQ4,QAR2,QAR2/A,QA2,QA2/A,QC12,QC12/A,QD,QD/A,QDA,QE,QE/A,QH,QH/A,QHB2,QHC,QHE,QHP1,QHP1/A,QHQ4,QHQ4/A,QHZ,QKA2,QMH,QMH/A,QMX2,QP,QP/A,QT,QT/A,QTC2,QTC2/A,QW24,QX,QX/A,QXB,QXB7,QXB7/A,QXC,QXC/A,QXC9,QXC9/A,QXE,QXE/A,QXEB,QXE4,QXE4/A,QXQ4,QXQ4/A,QXU,QXU/A,RA,RA2,RA2/A,RD,RD/A,RH,RHE,RHE4,RHQ4,RHQ4/A,RJ,RJ/A,RSC2,RSS1,RSS1/A,RTB2,RTB2/A,RX,RX/A,RXQ4,RXQ4/A,SD,SD/A,SDB1,SDB3,SDB3/A,SE,SE/A,SH,SHE,SHEZ,SJ,SJ/A,SJC,SJC1,SJC1/A,SJC5,SJC5/A,SJG,SJG/A,SJP,SK,SMS,SMS/A,SMX2,SMX2/A,SNC1,SNE1,SNR,SNR/A,STP,STP/A,STQ,STQ/A,SW,SWE,SX,SX/A,SBX,SXE,SXEB,SXE4,SXE4/A,SXQ4,SXQ4/A,SXU,SXU/A,VA,VAH1,VA2,VA2/A,VDG2,VDG2/A,VH,VH/A,VH12,VH12/A,VMT2,VMX,VNG,VSB1,VSB1/A,VS3,VS4,VTA,VTA2,VTA2/A,VTE2,VWC2,VWC2/A,VX,VX/A,VXB,VXB/A,VXB7,VXB7/A,VXE,VXE/A,VXEB,VXEB/A,VXQ4,VXQ4/A,VXQ7,VXQ7/A,VXU,VXU/A,VXU1,VXU1/A,WH,WJ,WJ/A,WKA,WKD6,WKD6/A,WKT2,WKT2/A,WKT4,WKT4/A,WMK
			-	(1)	1		

Ref. No.	Part No.	Description	Reqd. QTY			Serial No.	Parts catalogue code
			GX240K1	(1)	(2)		
6	28442-ZE2-W01	SPRING, STARTER RETURN	1	-	-	-----	EDN,EDN2,EDN2/A,EDS,EDS1,EDS1/A,EDS2,EDS2/A,EDS3,EDS6,EDS6/A,EDT1,EDT1/A,EDT2,EDT3,EDT6,EDT6/A,ED2,ED2/A,ED3,ED4,ED4/A,ED5,ED5/A,EN,EN2,EN2/A,ES,ES1,ES1/A,ES2,ES3,ES3/A,ET,ETS,ETX,HA,HAQ,HA2,HA2/A,HH,HHQ4,HHQ4/A,HTX,HX,HX/A,HXQ4,HXQ4/A,LD,LDB1,LDB3,LH,LH/A,LHE,LHE4,LHE4/A,LHZ,LJ,LJ/A,LJG,LJG/A,LJG1,LJS,LJS/A,LK,LNZ,LP,LP/A,LSS4,LSS5,LSS5/A,LSX,LSX/A,LT,LT/A,LW,LX,LX/A,LXF,LXQ4,LXQ4/A,LXZ,LX2,LX2/A,PA,PAE,PA2,PA2/A,PMT2,PMT2/A,PX,PX/A,QA,QAB2,QAB2/A,QAE,QAE2,QAE2/A,QAG,QAG/A,QAG2,QAG2/A,QAQ,QAQ4,QAR2,QAR2/A,QA2,QA2/A,QC12,QC12/A,QD,QD/A,QDA,QE,QE/A,QH,QH/A,QHB2,QHC,QHE,QHP1,QHP1/A,QHQ4,QHQ4/A,QHZ,QKA2,QMH,QMH/A,QMX2,QP,QP/A,QT,QT/A,QTC2,QTC2/A,QW24,QX,QX/A,QXB,QXB7,QXB7/A,QXC,QXC/A,QXC9,QXC9/A,QXE,QXE/A,QXEB,QXE4,QXE4/A,QXQ4,QXQ4/A,QXU,QXU/A,RA,RA2,RA2/A,RD,RD/A,RH,RHE,RHE4,RHQ4,RHQ4/A,RJ,RJ/A,RSC2,RSS1,RSS1/A,RTB2,RTB2/A,RX,RX/A,RXQ4,RXQ4/A,SD,SD/A,SDB1,SDB3,SDB3/A,SE,SE/A,SH,SHE,SHEZ,SJ,SJ/A,SJC,SJC1,SJC1/A,SJC5,SJC5/A,SJG,SJG/A,SJP,SK,SMS,SMS/A,SMX2,SMX2/A,SNC1,SNE1,SNR,SNR/A,STP,STP/A,STQ,STQ/A,SW,SWE,SX,SX/A,SBX,SXE,SXEB,SXE4,SXE4/A,SXQ4,SXQ4/A,SXU,SXU/A,VA,VAH1,VA2,VA2/A,VDG2,VDG2/A,VH,VH/A,VH12,VH12/A,VMT2,VMX,VNG,VSB1,VSB1/A,VS3,VS4,VTA,VTA2,VTA2/A,VTE2,VWC2,VWC2/A,VX,VX/A,VXB,VXB/A,VXB7,VXB7/A,VXE,VXE/A,VXEB,VXEB/A,VXQ4,VXQ4/A,VXQ7,VXQ7/A,VXU,VXU/A,VXU1,VXU1/A,WH,WJ,WJ/A,WKA,WKD6,WKD6/A,WKT2,WKT2/A,WKT4,WKT4/A,WMK
			-	(1)	1		
7	28443-ZE2-W01	SPRING, RATCHET	2	-	-	-----	EDN,EDN2,EDN2/A,EDS,EDS1,EDS1/A,EDS2,EDS2/A,EDS3,EDS6,EDS6/A,EDT1,EDT1/A,EDT2,EDT3,EDT6,EDT6/A,ED2,ED2/A,ED3,ED4,ED4/A,ED5,ED5/A,EN,EN2,EN2/A,ES,ES1,ES1/A,ES2,ES3,ES3/A,ET,ETS,ETX,HA,HAQ,HA2,HA2/A,HH,HHQ4,HHQ4/A,HTX,HX,HX/A,HXQ4,HXQ4/A,LD,LDB1,LDB3,LH,LH/A,LHE,LHE4,LHE4/A,LHZ,LJ,LJ/A,LJG,LJG/A,LJG1,LJS,LJS/A,LK,LNZ,LP,LP/A,LSS4,LSS5,LSS5/A,LSX,LSX/A,LT,LT/A,LW,LX,LX/A,LXF,LXQ4,LXQ4/A,LXZ,LX2,LX2/A,PA,PAE,PA2,PA2/A,PMT2,PMT2/A,PX,PX/A,QA,QAB2,QAB2/A,QAE,QAE2,QAE2/A,QAG,QAG/A,QAG2,QAG2/A,QAQ,QAQ4,QAR2,QAR2/A,QA2,QA2/A,QC12,QC12/A,QD,QD/A,QDA,QE,QE/A,QH,QH/A,QHB2,QHC,QHE,QHP1,QHP1/A,QHQ4,QHQ4/A,QHZ,QKA2,QMH,QMH/A,QMX2,QP,QP/A,QT,QT/A,QTC2,QTC2/A,QW24,QX,QX/A,QXB,QXB7,QXB7/A,QXC,QXC/A,QXC9,QXC9/A,QXE,QXE/A,QXEB,QXE4,QXE4/A,QXQ4,QXQ4/A,QXU,QXU/A,RA,RA2,RA2/A,RD,RD/A,RH,RHE,RHE4,RHQ4,RHQ4/A,RJ,RJ/A,RSC2,RSS1,RSS1/A,RTB2,RTB2/A,RX,RX/A,RXQ4,RXQ4/A,SD,SD/A,SDB1,SDB3,SDB3/A,SE,SE/A,SH,SHE,SHEZ,SJ,SJ/A,SJC,SJC1,SJC1/A,SJC5,SJC5/A,SJG,SJG/A,SJP,SK,SMS,SMS/A,SMX2,SMX2/A,SNC1,SNE1,SNR,SNR/A,STP,STP/A,STQ,STQ/A,SW,SWE,SX,SX/A,SBX,SXE,SXEB,SXE4,SXE4/A,SXQ4,SXQ4/A,SXU,SXU/A,VA,VAH1,VA2,VA2/A,VDG2,VDG2/A,VH,VH/A,VH12,VH12/A,VMT2,VMX,VNG,VSB1,VSB1/A,VS3,VS4,VTA,VTA2,VTA2/A,VTE2,VWC2,VWC2/A,VX,VX/A,VXB,VXB/A,VXB7,VXB7/A,VXE,VXE/A,VXEB,VXEB/A,VXQ4,VXQ4/A,VXQ7,VXQ7/A,VXU,VXU/A,VXU1,VXU1/A,WH,WJ,WJ/A,WKA,WKD6,WKD6/A,WKT2,WKT2/A,WKT4,WKT4/A,WMK
			-	(2)	2		



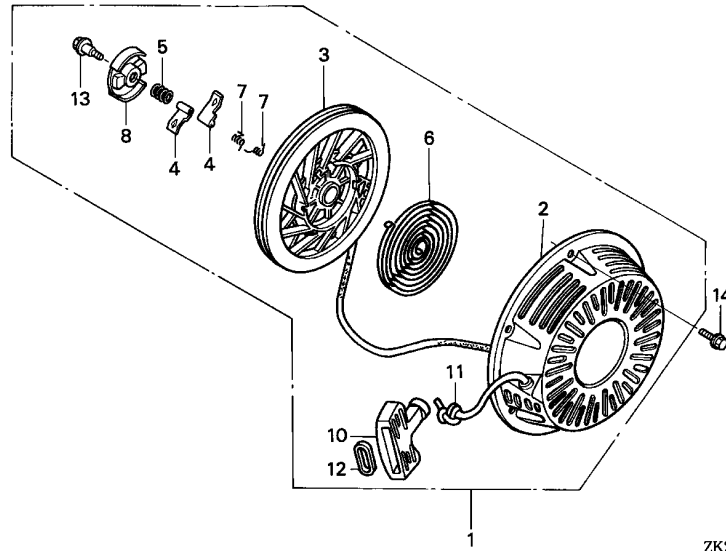

ZK20-E1100A



Ref. No.	Part No.	Description	Reqd. QTY			Serial No.	Parts catalogue code
			(1)	(2)	(3)		
8	28444-ZE2-W01	RETAINER, SPRING	1	-	-	-----	EDN,EDN2,EDN2/A,EDS,EDS1,EDS1/A,EDS2,EDS2/A,EDS3,EDS6,EDS6/A,EDT1,EDT1/A,EDT2,EDT3,EDT6,EDT6/A,ED2,ED2/A,ED3,ED4,ED4/A,ED5,ED5/A,EN,EN2,EN2/A,ES,ES1,ES1/A,ES2,ES3,ES3/A,ET,ETS,ETX,HA,HAQ,HA2,HA2/A,HH,HHQ4,HHQ4/A,HTX,HX,HX/A,HXQ4,HXQ4/A,LD,LDB1,LDB3,LH,LH/A,LHE,LHE4,LHE4/A,LHZ,LJ,LJ/A,LJG,LJG/A,LJG1,LJS,LJS/A,LK,LNZ,LP,LP/A,LSS4,LSS5,LSS5/A,LSX,LSX/A,LT,LT/A,LW,LX,LX/A,LXF,LXQ4,LXQ4/A,LXZ,LX2,LX2/A,PA,PAE,PA2,PA2/A,PMT2,PMT2/A,PX,PX/A,QA,QAB2,QAB2/A,QAE,QAE2,QAE2/A,QAG,QAG/A,QAG2,QAG2/A,QAQ,QAQ4,QAR2,QAR2/A,QA2,QA2/A,QC12,QC12/A,QD,QD/A,QDA,QE,QE/A,QH,QH/A,QHB2,QHC,QHE,QHP1,QHP1/A,QHQ4,QHQ4/A,QHZ,QKA2,QMH,QMH/A,QMX2,QP,QP/A,QT,QT/A,QTC2,QTC2/A,QW24,QX,QX/A,QXB,QXB7,QXB7/A,QXC,QXC/A,QXC9,QXC9/A,QXE,QXE/A,QXEB,QXE4,QXE4/A,QXQ4,QXQ4/A,QXU,QXU/A,RA,RA2,RA2/A,RD,RD/A,RH,RHE,RHE4,RHQ4,RHQ4/A,RJ,RJ/A,RSC2,RSS1,RSS1/A,RTB2,RTB2/A,RX,RX/A,RXQ4,RXQ4/A,SD,SD/A,SDB1,SDB3,SDB3/A,SE,SE/A,SH,SHE,SHEZ,SJ,SJ/A,SJC,SJC1,SJC1/A,SJC5,SJC5/A,SJG,SJG/A,SJP,SK,SMS,SMS/A,SMX2,SMX2/A,SNC1,SNE1,SNR,SNR/A,STP,STP/A,STQ,STQ/A,SW,SWE,SX,SX/A,SBX,SXE,SXEB,SXE4,SXE4/A,SXQ4,SXQ4/A,SXU,SXU/A,VA,VAH1,VA2,VA2/A,VDG2,VDG2/A,VH,VH/A,VH12,VH12/A,VMT2,VMX,VNG,VSB1,VSB1/A,VS3,VS4,VTA,VTA2,VTA2/A,VTE2,VWC2,VWC2/A,VX,VX/A,VXB,VXB/A,VXB7,VXB7/A,VXE,VXE/A,VXEB,VXEB/A,VXQ4,VXQ4/A,VXQ7,VXQ7/A,VXU,VXU/A,VXU1,VXU1/A,WH,WJ,WJ/A,WKA,WKD6,WKD6/A,WKT2,WKT2/A,WKT4,WKT4/A,WMK
			-	(1)	1		

Ref. No.	Part No.	Description	Reqd. QTY			Serial No.	Parts catalogue code
			(1)	(2)	(3)		
10	28461-ZE2-W02	GRIP, STARTER	1	-	-	-	EDN,EDN2,EDN2/A,EDS,EDS1,EDS1/A,EDS2,EDS2/A,EDS3,EDS6,EDS6/A,EDT1,EDT1/A,EDT2,EDT3,EDT6,EDT6/A,ED2,ED2/A,ED3,ED4,ED4/A,ED5,ED5/A,EN,EN2,EN2/A,ES,ES1,ES1/A,ES2,ES3,ES3/A,ET,ETS,ETX,HA,HAQ,HA2,HA2/A,HH,HHQ4,HHQ4/A,HTX,HX,HX/A,HXQ4,HXQ4/A,LD,LDB1,LDB3,LH,LH/A,LHE,LHE4,LHE4/A,LHZ,LJ,LJ/A,LJG,LJG/A,LJG1,LJS,LJS/A,LK,LNZ,LP,LP/A,LSS4,LSS5,LSS5/A,LSX,LSX/A,LT,LT/A,LW,LX,LX/A,LXF,LXQ4,LXQ4/A,LX2,LX2/A,PA,PAE,PA2,PA2/A,PMT2,PMT2/A,PX,PX/A,QA,QAB2,QAB2/A,QAE,QAE2,QAE2/A,QAG,QAG/A,QAG2,QAG2/A,QAQ,QAQ4,QAR2,QAR2/A,QA2,QA2/A,QC12,QC12/A,QD,QD/A,QDA,QE,QE/A,QH,QH/A,QHB2,QHC,QHE,QHP1,QHP1/A,QHQ4,QHQ4/A,QHZ,QKA2,QMH,QMH/A,QMX2,QP,QP/A,QT,QT/A,QTC2,QTC2/A,QW24,QX,QX/A,QXB,QXB7,QXB7/A,QXC,QXC/A,QXC9,QXC9/A,QXE,QXE/A,QXEB,QXE4,QXE4/A,QXQ4,QXQ4/A,QXU,QXU/A,RA,RA2,RA2/A,RD,RD/A,RH,RHE,RHE4,RHQ4,RHQ4/A,RJ,RJ/A,RSC2,RSS1,RSS1/A,RHB2,RTB2/A,RX,RX/A,RXQ4,RXQ4/A,SD,SD/A,SDB1,SDB3,SDB3/A,SE,SE/A,SH,SHE,SHEZ,SJ,SJ/A,SJC,SJC1,SJC1/A,SJC5,SJC5/A,SJG,SJG/A,SJP,SK,SMS,SMS/A,SMX2,SMX2/A,SNC1,SNE1,SNR,SNR/A,STP,STP/A,STQ,STQ/A,SW,SWE,SX,SX/A,SXB,SXE,SXEB,SXE4,SXE4/A,SXQ4,SXQ4/A,SXU,SXU/A,VA,VAH1,VA2,VA2/A,VDG2,VDG2/A,VH,VH/A,VH12,VH12/A,VMT2,VMX,VNG,VS1,VS1/A,VS3,VS4,VTA,VTA2,VTA2/A,VTE2,VWC2,VWC2/A,VX,VX/A,VXB,VXB7,VXB7/A,VXE,VXE/A,VXEB,VXEB/A,VXQ4,VXQ4/A,VXQ7,VXQ7/A,VXU,VXU/A,VXU1,VXU1/A,WH,WJ,WJ/A,WKA,WKD6,WKD6/A,WKT2,WKT2/A,WKT4,WKT4/A,WMK
			-	(1)	1		
11	28462-ZE2-W01	ROPE, RECOIL STARTER	1	(1)	-	-	EDS,EN,ET,ETS,ETX,HA,HAQ,HH,LDB1,LK,LW,LX2,PA,PAE,P1,QA,QAE,QAQ,QDA,QHC,QHE,QKA2,QXB,QXEB,RA,RH,RHE,RHE4,SH,SHEZ,SJP,SK,SNC1,SNE1,SW,SWE,SXB,SXE,SXEB,VA,VAH1,VNG,VTA,VTE2,V1,WH,WKA,W1,W1/A
			1	(1)	-	3793540	EDN,EDN2,EDS1,EDS2,EDS3,EDT1,EDT2,ED2,ED3,ED4,ED5,ES,ES1,ES3,HA2,HHQ4,HTX,HX,HXQ4,LD,LDB3,LH,LHE,LHE4,LHZ,LJ,LJG,LJG1,LNZ,LP,LSS4,LSS5,LSX,LX,LXQ4,LX2,L1,PA2,PMT2,PX,QAE2,QAG2,QAQ4,QAR2,QA2,QC12,QD,QE,QH,QHP1,QHQ4,QHZ,QMH,QMX2,QP,QT,QX,QXC,QXC9,QXE,QXE4,QXQ4,QXU,Q1,RA2,RD,RHQ4,RJ,RSC2,RSS1,RTB2,RX,RXQ4,R1,SD,SDB1,SDB3,SE,SHE,SJ,SJC,SJC1,SJC5,SJG,SMS,SMX2,SNR,STP,STQ,SX,SXE4,SXQ4,SXU,S1,VA2,VH,VH12,VMX,VS1,VWC2,VX,VXB,VXE,VXEB,VXQ4,VXU,VXU1,WJ,WKT2,WKT4
	28462-ZE2-W11	1	(1)	-	3793541	EDN,EDN2,EDS1,EDS2,EDS3,EDT1,EDT2,ED2,ED3,ED4,ED5,ES,ES1,ES3,HA2,HHQ4,HTX,HX,HXQ4,LD,LDB3,LH,LHE,LHE4,LHZ,LJ,LJG,LJG1,LNZ,LP,LSS4,LSS5,LSX,LX,LXQ4,LX2,L1,L1/A,PA2,PMT2,PX,QAE2,QAG2,QAQ4,QAR2,QA2,QC12,QD,QE,QH,QHP1,QHQ4,QHZ,QMH,QMX2,QP,QT,QX,QXC,QXC9,QXE,QXE4,QXQ4,QXU,Q1,Q1/A,RA2,RD,RHQ4,RJ,RSC2,RSS1,RTB2,RX,RXQ4,R1,R1/A,SD,SDB1,SDB3,SE,SHE,SJ,SJC,SJC1,SJC5,SJG,SMS,SMX2,SNR,STP,STQ,SX,SXE4,SXQ4,SXU,S1,S1/A,VA2,VH,VH12,VMX,VS1,VWC2,VX,VXB,VXE,VXEB,VXQ4,VXU,VXU1,WJ,WKT2,WKT4
			1	-	-	-	EDN2/A,EDS1/A,EDS2/A,EDS6,EDS6/A,EDT1/A,EDT3,EDT6,EDT6/A,ED2/A,ED4/A,ED5/A,EN2,EN2/A,ES1/A,ES2,ES3/A,HA2/A,HHQ4/A,HX/A,HXQ4/A,LH/A,LHE4/A,LJ/A,LJG/A,LJS,LJS/A,LP/A,LSS5/A,LSX/A,LT,LT/A,LX/A,LXF,LXQ4/A,LX2/A,PA2/A,PMT2/A,PX/A,QAB2,QAB2/A,QAE2/A,QAG,QAG/A,QAG2/A,QAR2/A,QA2/A,QC12/A,QD/A,QE/A,QH/A,QHB2,QHP1/A,QHQ4/A,QMH/A,QP/A,QT/A,QTC2,QTC2/A,QW24,QX/A,QXB7,QXB7/A,QXC/A,QXC9/A,QXE/A,QXE4/A,QXQ4/A,QXU/A,RA2/A,RD/A,RHQ4/A,RJ/A,RSS1/A,RTB2/A,RX/A,RXQ4/A,SD/A,SDB3/A,SE/A,SJ/A,SJC1/A,SJC5/A,SJG/A,SMS/A,SMX2/A,SNR/A,STP/A,STQ/A,SX/A,SXE4/A,SXQ4/A,SXU/A,VA2/A,VDG2,VDG2/A,VH/A,VH12/A,VMT2,VS1/A,VS3,VS4,VTA2,VTA2/A,VWC2/A,VX/A,VXB/A,VXB7/VXB7/A,VXE/A,VXEB/A,VXQ4/A,VXQ7/VXQ7/A,VXU/A,VXU1/A,WJ/A,WKD6,WKD6/A,WKT2/A,WKT4/A,WMK
			-	-	1		



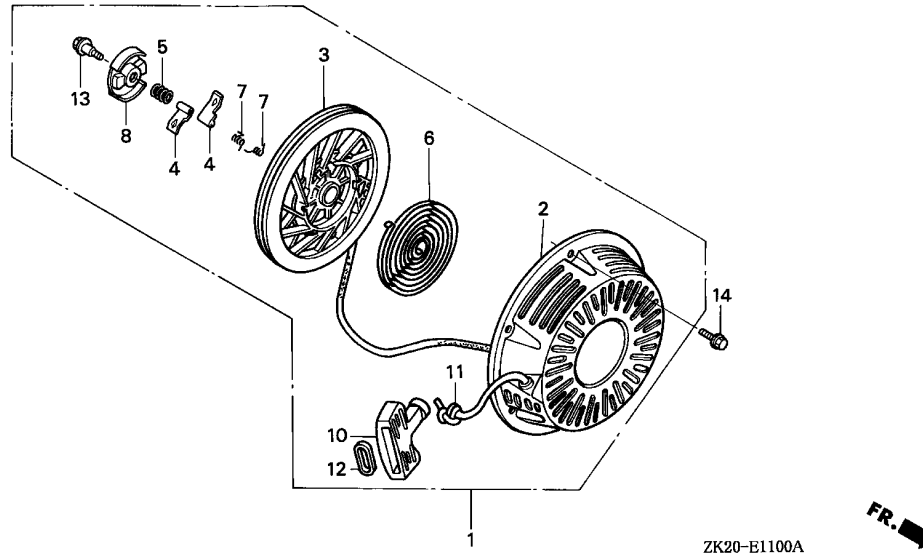

ZK20-E1100A

Ref. No.	Part No.	Description	Reqd. QTY			Serial No.	Parts catalogue code
			(1)	(2)	(3)		
12	28469-ZE2-W01	GRIP, REINFORCEMENT	1	(1)	1	-----	EDS,EN,ET,ETS,ETX,HA,HAQ,HH,LDB1,LK,LW,LXZ,PA,PAE,P1,QA,QAE,QAQ,QDA,QHC,QHE,QKA2,QXB,QXEB,RA,RH,RHE,RHE4,SH,SHEZ,SJP,SK,SNC1,SNE1,SW,SWE,SXB,SXE,SXEB,VA,VAH1,VNG,VTA,VTE2,VXP,VXQP,V1,WH,WKA,W1,W1/A
			1	(1)	-	-----	3793540 EDN,EDN2,EDS1,EDS2,EDS3,EDT1,EDT2,ED2,ED3,ED4,ED5,ES,ES1,ES3,HA2,HHQ4,HTX,HX,HXQ4,LD,LDB3,LH,LHE,LHE4,LHZ,LJ,LJG,LJG1,LNZ,LP,LSS4,LSS5,LSX,LX,LXQ4,LX2,L1,PAZ,PMT2,PX,QAE2,QAG2,QAQ4,QAR2,QA2,QC12,QD,QE,QH,QHP1,QHQ4,QHZ,QMH,QMX2,QP,QT,QX,QXC,QXC9,QXE,QXE4,QXQ4,QXU,Q1,RA2,RD,RHQ4,RJ,RSC2,RSS1,RTB2,RX,RXQ4,R1,SD,SDB1,SDB3,SE,SHE,SJ,SJC,SJC1,SJC5,SJG,SMS,SMX2,SNR,STP,STQ,SX,SXE4,SXQ4,SXU,S1,VA2,VH,VH12,VMX,VS1,VTA2,VWC2,VX,VXB,VXE,VXEB,VXQ4,VXU,VXU1,WJ,WKT2,WKT4

Ref. No.	Part No.	Description	Reqd. QTY			Serial No.	Parts catalogue code
			(1)	(2)	(3)		
13	90004-ZE2-W01	SCREW, CENTER	1	-	-	-----	EDN,EDN2,EDN2/A,EDS,EDS1,EDS1/A,EDS2,EDS2/A,EDS3,EDS6,EDS6/A,EDT1,EDT1/A,EDT2,EDT3,EDT6,EDT6/A,ED2,ED2/A,ED3,ED4,ED4/A,ED5,ED5/A,EN,EN2,EN2/A,ES,ES1,ES1/A,ES2,ES3,ES3/A,ET,ETS,ETX,HA,HAQ,HA2,HA2/A,HH,HHQ4,HHQ4/A,HTX,HX,HX/A,HXQ4,HXQ4/A,LD,LDB1,LDB3,LH,LA/LHE,LHE4,LHE4/A,LHZ,LJ,LJ/A,LJG,LJG/A,LJG1,LJS,LJS/A,LK,LNZ,LP,LP/A,LSS4,LSS5,LSS5/A,LSX,LSX/A,LT,LT/A,LW,LX,LX/A,LXF,LXQ4,LXQ4/A,LXZ,LX2,LX2/A,PA,PAE,PA2,PA2/A,PMT2,PMT2/A,PX,PX/A,QA,QAB2,QAB2/A,QAE,QAE2,QAE2/A,QAG,QAG/A,QAG2,QAG2/A,QAQ,QAQ4,QAR2,QAR2/A,QA2,QA2/A,QC12,QC12/A,QD,QD/A,QDA,QE,QE/A,QH,QH/A,QHB2,QHC,QHE,QHP1,QHP1/A,QHQ4,QHQ4/A,QHZ,QKA2,QMH,QMH/A,QMX2,QP,QP/A,QT,QT/A,QTC2,QTC2/A,QW24,QX,QX/A,QXB,QXB7,QXB7/A,QXC,QXC/A,QXC9,QXC9/A,QXE,QXE/A,QXEB,QXE4,QXE4/A,QXQ4,QXQ4/A,QXU,QXU/A,RA,RA2,RA2/A,RD,RD/A,RH,RHE,RHE4,RHQ4,RHQ4/A,RJ,RJ/A,RSC2,RSS1,RSS1/A,RTB2,RTB2/A,RX,RX/A,RXQ4,RXQ4/A,SD,SD/A,SDB1,SDB3,SDB3/A,SE,SE/A,SH,SHE,SHEZ,SJ,SJ/A,SJC,SJC1,SJC1/A,SJC5,SJC5/A,SJG,SJG/A,SJP,SK,SMS,SMS/A,SMX2,SMX2/A,SNC1,SNE1,SNR,SNR/A,STP,STP/A,STQ,STQ/A,SW,SWE,SX,SX/A,SXB,SXE,SXEB,SXE4,SXE4/A,SXQ4,SXQ4/A,SXU,SXU/A,VA,VAH1,VA2,VA2/A,VDG2,VDG2/A,VH,VH/A,VH12,VH12/A,VMT2,VMX,VNG,VSB1,VSB1/A,VS3,VS4,VTA2,VTA2/A,VTE2,VWC2,VWC2/A,VX,VX/A,VXB,VXB7,VXB7/A,VXE,VXE/A,VXEB,VXEB/A,VXQ4,VXQ4/A,VXQ7,VXQ7/A,VXU,VXU/A,VXU1,VXU1/A,WH,WJ,WJ/A,WKA,WKD6,WKD6/A,WKT2,WKT2/A,WKT4,WKT4/A,WMK
14	90008-ZE2-003	BOLT, FLANGE, 6X10	3	(1) 3	1	-----	EDN2,EDN2/A,EDS1,EDS1/A,EDS2,EDS2/A,EDS6,EDS6/A,EDT1,EDT1/A,EDT3,EDT6,EDT6/A,ED2,ED2/A,ED4,ED4/A,ED5,ED5/A,EN2,EN2/A,ES1/A,ES2,ES3,ES3/A,HA2,HA2/A,HHQ4,HHQ4/A,HX,HX/A,HXQ4,HXQ4/A,LH,LA/LHE4,LHE4/A,LJ/A,LJG,LJG/A,LJS,LJS/A,LNZ,LP,LP/A,LSS5,LSS5/A,LSX,LSX/A,LT,LT/A,LX,LX/A,LXF,LXQ4,LXQ4/A,LX2,LX2/A,L1,L1/A,PA2,PA2/A,PMT2,PMT2/A,PX,PX/A,QAB2,QAB2/A,QAE2,QAE2/A,QAG,QAG/A,QAG2,QAG2/A,QAR2,QAR2/A,QA2,QA2/A,QC12,QC12/A,QD,QD/A,QE,QE/A,QH,QH/A,QHB2,QHP1,QHP1/A,QHQ4,QHQ4/A,QMH,QMH/A,QP,QP/A,QT,QT/A,QTC2,QTC2/A,QW24,QX,QX/A,QXB7,QXB7/A,QXC,QXC/A,QXC9,QXC9/A,QXE,QXE/A,QXE4,QXE4/A,QXQ4,QXQ4/A,QXU,QXU/A,Q1,Q1/A,RA2,RA2/A,RD,RD/A,RHQ4,RHQ4/A,RJ/A,RSS1,RSS1/A,RTB2,RTB2/A,RX,RX/A,RXQ4,RXQ4/A,R1,R1/A,SD,SD/A,SDB3,SDB3/A,SE,SE/A,SJ/A,SJC1,SJC1/A,SJC5,SJC5/A,SJG,SJG/A,SMS,SMS/A,SMX2,SMX2/A,SNR,SNR/A,STP/A,STQ/A,SX,SX/A,SXE4,SXE4/A,SXQ4,SXQ4/A,SXU,SXU/A,S1,S1/A,VA2,VA2/A,VDG2,VDG2/A,VH,VH/A,VH12,VH12/A,VMT2,VMX,VSB1,VSB1/A,VS3,VS4,VTA2,VTA2/A,VWC2,VWC2/A,VX,VX/A,VXB,VXB7,VXB7/A,VXE,VXE/A,VXEB,VXEB/A,VXQ4,VXQ4/A,VXQ7,VXQ7/A,VXU,VXU/A,VXU1,VXU1/A,WJ/A,WKD6,WKD6/A,WKT2,WKT2/A,WKT4,WKT4/A,WMK W1/A
	90011-ZG0-000	BOLT, FLANGE, 6X8	3	-	3	-----	HA,LJ,LK,PA,QA,QAE,RA,RJ,SJ,SJP,SK,STP,STQ,VA,VAH1,VTA,WJ,WKA
	95701-06008-00	3	(3)	-	-----	EDN,EDS,EDS3,EDT2,ED3,EN,ES,ES1,ET,ETS,ETX,HAQ,HH,HTX,LD,LDB1,LDB3,LHE,LHZ,LJG1,LSS4,LW,LXZ,L1,PAE,P1,QA,QAE,QAQ,QAQ4,QDA,QHC,QHE,QHZ,QKA2,QMX2,QXB,QXEB,Q1,RH,RHE,RHE4,RSC2,R1,SDB1,SH,SHE,SHEZ,SJC,SNC1,SNE1,SW,SWE,SXB,SXE,SXEB,VNG,VTE2,V1,WH,W1



E-11-1

RECOIL STARTER(2)

15

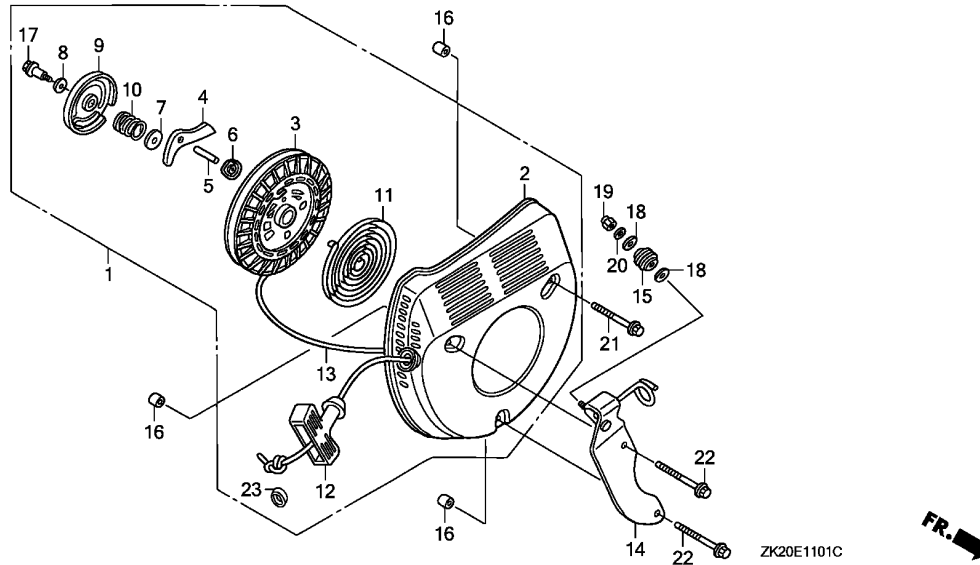

Ref. No.	L.O.N.	(Relative ref. Number) Description	F.R.T.
1	1121B9	STARTER, RECOIL	0.1
3	1121B1	REEL, RECOIL STARTER	0.3
4	1121B0	RATCHET, STARTER AND/OR SPRING, RATCHET	0.2
9	1121E8	COVER, STARTER REEL	0.2
11	1121B7	SPRING, RECOIL STARTER RETURN	0.3
13	1121B3	ROPE, RECOIL STARTER	0.3

2

Ref. No.	Part No.	Description	Reqd. QTY			Serial No.	Parts catalogue code
			(1)	(2)	(3)		
1	28400-ZE2-A01ZB	STARTER ASSY., RECOIL	1	-	-	3205956	LM9
		R8.....BRIGHT RED	1	-	-	3205957	LM9
	28400-ZE2-A02ZB	*R8*.....BRIGHT RED	1	-	-	3205957	LM9
2	28410-ZE2-A01ZB	CASE COMP., RECOIL STARTER	1	-	-	3205956	LM9
		R8.....BRIGHT RED	1	-	-	3205957	LM9
	28410-ZE2-A02ZB	CASE COMP., STARTER	1	-	-	3205957	LM9
		R8.....BRIGHT RED	1	-	-	3205957	LM9
3	28420-ZE8-812	REEL COMP., STARTER	1	-	-	3205956	LM9
4	28422-ZE8-811	RATCHET, STARTER	1	-	-	3205957	LM9
	28422-ZG3-004		1	-	-	3205957	LM9
5	28423-ZE1-711	SHAFT, RATCHET	1	-	-	3205956	LM9
	28423-ZG3-004		1	-	-	3205957	LM9
6	28424-ZE1-712	PLATE, GUIDE	1	-	-	3205956	LM9
7	28431-ZE1-711	PLATE A, FRICTION	1	-	-	3205957	LM9
	28431-ZG3-004		1	-	-	3205957	LM9
8	28432-ZG0-003	PLATE B, FRICTION	1	-	-	3205956	LM9
	28432-ZG0-004		1	-	-	3205957	LM9
9	28434-ZE8-812	COVER, STARTER REEL	1	-	-	3205956	LM9
10	28441-ZE1-711	SPRING, FRICTION	1	-	-	3205956	LM9
	28441-ZG3-004		1	-	-	3205957	LM9
11	28442-ZE1-713	SPRING, RETURN	1	-	-	3205956	LM9
12	28461-ZE8-811	GRIP, STARTER	1	-	-	3205957	LM9
	28461-ZE2-P51		1	-	-	3205957	LM9
13	28462-ZE8-811	ROPE, STARTER	1	-	-	3205956	LM9
	28462-ZE2-A02		1	-	-	3205957	LM9
14	28480-ZE2-U50	STAY, RECOIL (MAMETORA)	1	-	-	3077713	LM9
15	28481-881-810	IDLER, VERTICAL STARTER	1	-	-	3077713	LM9

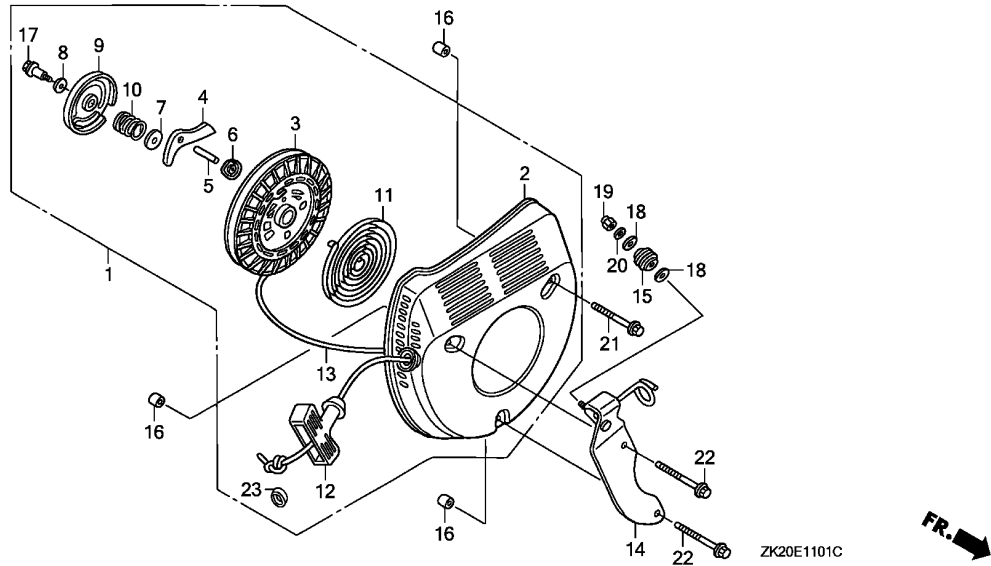

Ref. No.	Part No.	Description	Reqd. QTY			Serial No.	Parts catalogue code
			(1)	(2)	(3)		
15)	28481-ZE2-U50	IDLER, VERTICAL STARTER	1	-	-	3077714 -----	LM9
16	75133-960-000	COLLAR, ROTO-STOP	3	-	-	-----	LM9
17	90003-ZG0-003	BOLT, REEL COVER	1	-	-	3205956	LM9
	90003-ZG3-004	BOLT, 6MM	1	-	-	3205957	LM9
18	90401-437-000	WASHER, PLAIN, 10MM	2	-	-	-----	LM9
19	94021-06000-0S	NUT, CAP, 6MM	1	-	-	-----	LM9
20	94103-06000	WASHER, PLAIN, 6MM	1	-	-	-----	LM9
21	95701-06060-00	BOLT, FLANGE, 6X60	1	-	-	-----	LM9
22	95701-06075-00	BOLT, FLANGE, 6X75	2	-	-	-----	LM9
23	28469-ZE2-W01	GRIP, REINFORCEMENT	1	-	-	3205957	LM9



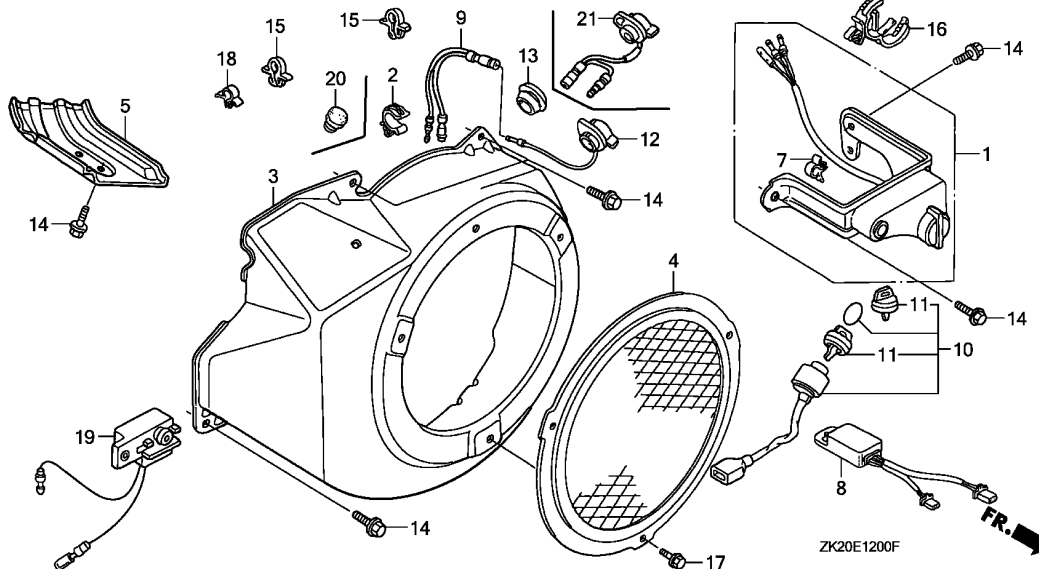

Ref. No.	L.O.N.	(Relative ref. Number) Description	F.R.T.
1	6151C6	SWITCH, OIL ALERT UNIT	0.1
3	1141G8	COVER, ENGINE COOLING FAN	0.2
8	6131B7	RECTIFIER, REGULATOR	0.2
9	6111H1	SUB HARNESS, ENGINE SWITCH/ ENGINE STOP SWITCH	0.2
10	6151E1	SWITCH, COMBINATION	0.2
12		(21)	
	6151D9	SWITCH, ENGINE STOP	0.2
19	6151A0	ALERT UNIT, ENGINE OIL	0.1

Ref. No.	Part No.	Description	Reqd. QTY			Serial No.	Parts catalogue code
			(1)	(2)	(3)		
			GX240K1				
1	15520-ZE2-003	ALERT UNIT, OIL	1	(1)	-	3116814	ES1,HA,HX,LX,LXZ,L1,PA,PX,P1,QA,QX,QXB,QXC,Q1,RA,RX,R1,SJP,SNR,SX SXB,S1,VA,VAH1,VNG,VX,VXB,V1,W1
2	16731-ZE2-003	CLIP, TUBE	1	-	-		ED3,ED4,ED4/A,ED5,ED5/A,EN,ES,ES1,ES1/A,ES2,ET,ETS,ETX,HA,HAQ,HA2 HA2/A,HH,HHQ4,HHQ4/A,HTX,HX,HX/A,HXQ4,HXQ4/A,LD,LDB1,LDB3,LH,LH/A LHE,LHE4,LHE4/A,LHZ,LJ,LJ/A,LJG,LJG/A,LJG1,LJS,LJS/A,LK,LKS,LKS/A LM9,LNJ,LNZ,LP,LP/A,LSS4,LSS5,LSS5/A,LSX,LSX/A,LT,LT/A,LW,LX,LX/A LXF,LXQ4,LXQ4/A,LXZ,LX2,LX2/A,PA,PAE,PA2,PA2/A,PMT2,PMT2/A,PX PX/A,QA,QAB2,QAB2/A,QAE,QAE2,QAE2/A,QAG,QAG/A,QAG2,QAG2/A,QAQ QAQ4,QAR2,QAR2/A,QA2,QA2/A,QC12,QC12/A,QD,QD/A,QDA,QE,QE/A,QH QH/A,QHB2,QHC,QHE,QHP1,QHP1/A,QHQ4,QHQ4/A,QHZ,QKA2,QMH,QMH/A,QMX2 QP,QP/A,QT,QT/A,QTC2,QTC2/A,QW24,QX,QX/A,QXB,QXB7,QXB7/A,QXC QXC/A,QXC9,QXC9/A,QXE,QXE/A,QXEB,QXE4,QXE4/A,QXQ4,QXQ4/A,QXU QXU/A,RA,RA2,RA2/A,RD,RD/A,RH,RHE,RHE4,RHQ4,RHQ4/A,RJ,RJ/A,RSS1 RSS1/A,RTB2,RTB2/A,RX,RX/A,RXQ4,RXQ4/A,SD,SD/A,SDB1,SDB3,SDB3/A SE,SE/A,SH,SHE,SHEZ,SHW,SHW/A,SJ,SJ/A,SJC,SJC1,SJC1/A,SJC5,SJC5/A SJG,SJG/A,SJP,SK,SMS,SMS/A,SMX2,SMX2/A,SNC1,SNE1,SNR,SNR/A,STP STP/A,STQ,STQ/A,SW,SWE,SX,SX/A,SXB,SXE,SXEB,SXE4,SXE4/A,SXQ4 SXQ4/A,SXU,SXU/A,VA,VAH1,VA2,VA2/A,VDG2,VDG2/A,VH,VH/A,VH12 VH12/A,VMT2,VMX,VNG,VTA,VTA2,VTA2/A,VWC2,VWC2/A,VX,VX/A,VXB,VXB/A VXB7,VXB7/A,VXE,VXE/A,VXEB,VXEB/A,VXQ4,VXQ4/A,VXQ7,VXQ7/A,VXU VXU/A,VXU1,VXU1/A,WH,WJ,WJ/A,WKA,WKD6,WKD6/A,WKT2,WKT2/A,WKT4 WKT4/A,WMK
			-	1	-		

Ref. No.	Part No.	Description	Reqd. QTY			Serial No.	Parts catalogue code
			(1)	(2)	(3)		
3	19610-ZE2-010ZA	COVER COMP., FAN *R8*.....BRIGHT RED	1	(1)	1	-----	ED3,ED4,ED5,EN,ES,ES1,ET,ETS,ETX,HA,HAQ,HA2,HH,HHQ4,HTX,HX,HXQ4 LD,LDB1,LDB3,LH,LHE,LHE4,LHZ,LJ,LJG,LJG1,LJS,LK,LKS,LM9,LNJ,LNZ LP,LSS4,LSS5,LSX,LT,LW,LX,LXQ4,LXZ,LX2,L1,PA,PAE,PA2,PX,P1,QA QAB2,QAE,QAE2,QAG,QAG2,QAQ,QAQ4,QAR2,QA2,QC12,QD,QDA,QE,QH,QHC QHE,QHP1,QHQ4,QHZ,QKA2,QMH,QMX2,QP,QT,QTC2,QX,QXB,QXB7,QXC,QXC9 QXE,QXEB,QXE4,QXQ4,QXU,Q1,RA,RA2,RD,RH,RHE,RHE4,RHQ4,RJ,RSC2,RSS1 RTB2,RX,RXQ4,R1,SD,SDB1,SDB3,SE,SH,SHE,SHEZ,SHW,SJ,SJC,SJC1,SJC5 SJG,SJP,SK,SMS,SMX2,SNC1,SNE1,SNR,STP,STQ,SW,SWE,SX,SXB,SXE,SXB SXQ4,SXU,S1,VA,VAH1,VA2,VDG2,VH,VH12,VMX,VNG,VTA,VTA2,VX,VXB VXB7,VXE,VXEB,VXP,VXQP,VXQ4,VXQ7,VXU,VXU1,V1,WH,WJ,WKA,WKD6,WKT2 WKT4,W1
	19610-ZE2-010ZL	*R280*.....POWER RED	1	(1)	1	-----	ED4/A,ED5/A,ES1/A,ES2,HA2/A,HHQ4/A,HX/A,HXQ4/A,LH/A,LHE4/A,LJ/A LJG/A,LJS/A,LKS/A,LP/A,LSX/A,LT/A,LX/A,LXF,LXQ4/A,LX2/A,L1/A PA2/A,PX/A,QAB2/A,QAE2/A,QAG/A,QAG2/A,QAR2/A,QA2/A,QC12/A,QD/A QE/A,QH/A,QHB2,QHP1/A,QHQ4/A,QMH/A,QP/A,QT/A,QTC2/A,QX/A,QXB7/A QXC/A,QXC9/A,QXE/A,QXE4/A,QXQ4/A,QXU/A,Q1/A,RA2/A,RD/A,RHQ4/A RJ/A,RSS1/A,RTB2/A,RX/A,RXQ4/A,R1/A,SD/A,SDB3/A,SE/A,SHW/A,SJ/A SJC1/A,SJC5/A,SJG/A,SMS/A,SMX2/A,SNR/A,STP/A,STQ/A,SX/A,SXE4/A SXQ4/A,SXU/A,S1/A,VA2/A,VDG2/A,VH/A,VH12/A,VTA2/A,VX/A,VXB/A VXB7/A,VXE/A,VXEB/A,VXP/A,VXQ4/A,VXQ7/A,VXU/A,VXU1/A,WJ/A,WKD6/A WKT2/A,WKT4/A,WMK,W1/A
	19610-ZE2-700ZA	*R8*.....BRIGHT RED	1	-	-	-----	EDS,EDS1,EDS3,EDT1,ED2,ES3,VSB1
	19610-ZE2-010ZC	*NH1*.....BLACK	1	-	-	4460278	EDS1/A,EDT1/A,ED2/A,ES3/A,VSB1/A
			1	-	-	-----	ED4,ED4/A,ED5,ED5/A,ES1,ES1/A,ES2,HA2,HA2/A,LX2,LX2/A,PA2,PA2/A PMT2,PMT2/A,QAE2,QAE2/A,QAG,QAG/A,QAQ4,QAR2,QAR2/A,QA2,QA2/A,QMX2 QTC2,QTC2/A,QW24,QXC9,QXC9/A,RA2,RA2/A,SMX2,SMX2/A,SX,SX/A,SXU SXU/A,VA2,VA2/A,VTA2,VTA2/A,VWC2,VWC2/A,VXB7,VXB7/A,VXQ4,VXQ4/A
			1	-	-	3139635	HA,QA
			1	-	-	3187181	HAQ,QAQ
	19610-ZE2-010ZD	*T41*...BARTELL BLUE METALLIC	1	-	-	-----	QAQ4
			1	-	-	3139635	QA
	19610-ZE2-010ZG	*NH105*...MAT BLACK (#15-#20)	1	-	-	-----	VMT2,VWC2,VWC2/A,VXB7,VXB7/A
	19610-ZE2-010ZH	*Y131*.....LIGHTNING YELLOW	1	-	-	-----	ES1,ES1/A,ES2
	19610-ZE2-010ZJ	*T77*.....SEC WINE RED	1	-	-	-----	ES1,ES1/A,ES2
	19610-ZE2-010ZK	*T80*.....BAKELITE ORANGE	1	-	-	-----	ES1,ES1/A,ES2
	19610-ZE2-700ZD	*NH1*.....BLACK	1	-	-	-----	EDN,EDN2,EDN2/A,EDS1,EDS1/A,EDS2,EDS2/A,EDS6,EDS6/A,EDT1,EDT1/A EDT2,EDT3,EDT6,EDT6/A,ED2,ED2/A,EN2,EN2/A,ES3,ES3/A,VS3
			1	-	-	-----	ED2,ED2/A
	19610-ZE2-700ZH	*Y131*.....LIGHTNING YELLOW	1	-	-	-----	ED2,ED2/A,ES3,ES3/A
	19610-ZE2-700ZJ	*T77*.....SEC WINE RED	1	-	-	-----	ES3,ES3/A
	19610-ZE2-700ZK	*T80*.....BAKELITE ORANGE	1	-	-	-----	ED2,ED2/A,ES3,ES3/A
	19610-ZE2-700ZL	*R280*.....POWER RED	1	-	-	-----	EDT3,VS3
			1	-	-	4460279	EDS1/A,EDT1/A,ED2/A,ES3/A,QAR2/A,VSB1/A,VXQ4/A
			1	-	-	-----	VS3
4	19620-ZE2-000ZA	PROTECTOR COMP., FAN COVER *R8*.....BRIGHT RED	1	-	-	-----	LKS,LNJ,SHW,SHW/A
			1	-	-	4476951	LKS/A
	19620-ZE2-000ZD	*R280*.....POWER RED	1	-	-	4476952	LKS/A
	19620-ZE2-000ZC	*NH1*.....BLACK	1	-	-	-----	SHW,SHW/A



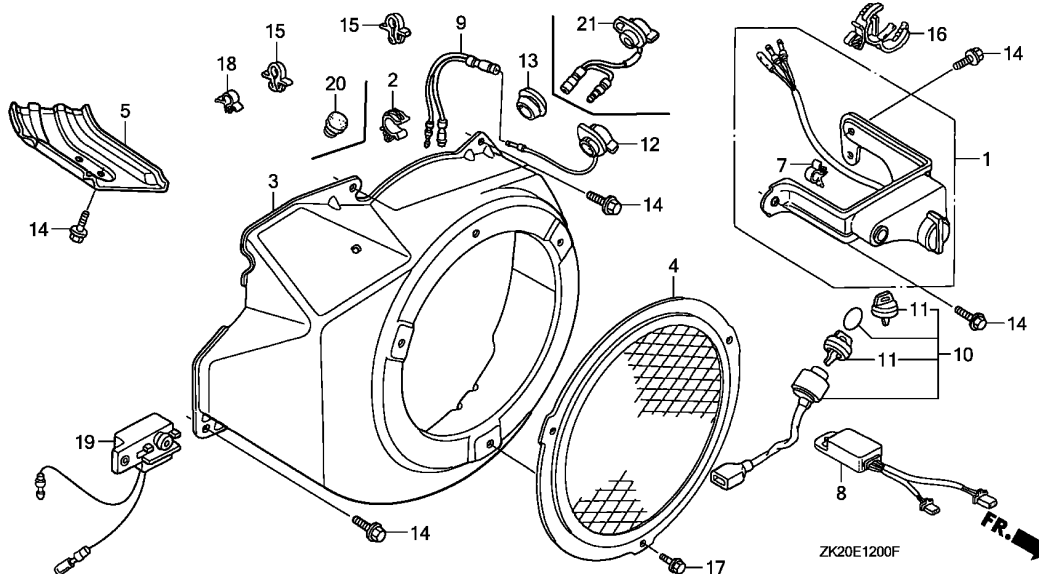

2

Ref. No.	Part No.	Description	Reqd. QTY			Serial No.	Parts catalogue code
			(1)	(2)	(3)		
5	19631-ZE2-D00	SHROUD	1	-	-	-----	EDN,EDN2,EDN2/A,EDS,EDS1,EDS1/A,EDS2,EDS2/A,EDS3,EDS6,EDS6/A,EDT1,EDT1/A,EDT2,EDT3,EDT6,EDT6/A,ED2,ED2/A,ED3,ED4,ED4/A,ED5,ED5/A,EN,EN2,EN2/A,ES,ES1,ES1/A,ES2,ES3,ES3/A,ET,ETS,ETX,HA,HAQ,HA2,HA2/A,HH,HHQ4,HHQ4/A,HTX,HX,HX/A,HXQ4,HXQ4/A,LD,LDB1,LDB3,LH,LH/A,LHE,LHE4,LHE4/A,LHZ,LJ,LJ/A,LJG,LJG/A,LJG1,LJS,LJS/A,LK,LKS,LKS/A,LM9,LNJ,LNZ,LP,LP/A,LSS4,LSS5,LSS5/A,LSX,LSX/A,LT,LT/A,LW,LX,LX/A,LXF,LXQ4,LXQ4/A,LXZ,LX2,LX2/A,PA,PAE,PA2,PA2/A,PMT2,PMT2/A,PX,PX/A,QA,QAB2,QAB2/A,QAE,QAE2,QAE2/A,QAG,QAG/A,QAG2,QAG2/A,QAQ,QAQ4,QAR2,QAR2/A,QA2,QA2/A,QC12,QC12/A,QD,QD/A,QDA,QE,QE/A,QH,QH/A,QHB2,QHC,QHE,QHP1,QHP1/A,QHQ4,QHQ4/A,QHZ,QKA2,QMH,QMH/A,QMX2,QP,QP/A,QT,QT/A,QTC2,QTC2/A,QW24,QX,QX/A,QXB,QXB7,QXB7/A,QXC,QXC/A,QXC9,QXC9/A,QXE,QXE/A,QXEB,QXE4,QXE4/A,QXQ4,QXQ4/A,QXU,QXU/A,RA,RA2,RA2/A,RD,RD/A,RH,RHE,RHE4,RHQ4,RHQ4/A,RJ,RJ/A,RSC2,RSS1,RSS1/A,RTB2,RTB2/A,RX,RX/A,RXQ4,RXQ4/A,SD,SD/A,SDB1,SDB3,SDB3/A,SE,SE/A,SH,SHE,SHEZ,SHW,SHW/A,SJ,SJ/A,SJC,SJC1,SJC1/A,SJC5,SJC5/A,SJG,SJG/A,SJP,SK,SMS,SMS/A,SMX2,SMX2/A,SNC1,SNE1,SNR,SNR/A,STP,STP/A,STQ,STQ/A,SW,SWE,SX,SX/A,SXB,SXE,SXEB,SXE4,SXE4/A,SXQ4,SXQ4/A,SXU,SXU/A,VA,VAH1,VA2,VA2/A,VDG2,VDG2/A,VH,VH/A,VH12,VH12/A,VMT2,VMX,VNG,VSB1,VSB1/A,VS3,VS4,VTA,VTA2,VTA2/A,VTE2,VWC2,VWC2/A,VX,VX/A,VXB,VXB/A,VXB7,VXB7/A,VXE,VXE/A,VXEB,VXEB/A,VXQ4,VXQ4/A,VXQ7,VXQ7/A,VXU,VXU/A,VXU1,VXU1/A,WH,WJ,WJ/A,WKA,WKD6,WKD6/A,WKT2,WKT2/A,WKT4,WKT4/A,WMK
			-	1	1		
7	30701-883-000	CLIP, HIGH TENSION CORD (8MM)	1	(1)	-	-----	3116814 ES1,HA,HX,LX,LXZ,L1,PA,PX,P1,QA,QX,QXB,QXC,Q1,RA,RX,R1,SJP,SNR,SX,SXB,S1,VA,VAH1,VNG,VX,VXB,V1,W1
8	31600-KE1-010	RECTIFIER COMP., REGULATOR ..	1	-	-	-----	LNJ,LNZ

Ref. No.	Part No.	Description	Reqd. QTY			Serial No.	Parts catalogue code		
			(1)	(2)	(3)				
9	32197-ZH8-003	SUB HARNESS	1	1	-	3116815	----- ETS,LXZ,P1,QA,QXB,SJP,SNR,SXB,VNG,V1		
			1	1	-	3116815	3566259 ES1,HA,HX,LX,L1,PA,PX,QX,QXC,Q1,RA,RX,R1, SX,S1,VA,VAH1,VX,VXB,W1		
			1	-	1	-----	-----	EDS,EDS1,EDS1/A,EDS2,EDS2/A,EDS3,EDS6,EDS6/A,EDT1,EDT1/A,EDT2	
								EDT3,EDT6,EDT6/A,ED2,ED2/A,ED5,ED5/A,EN2,EN2/A,LSS4,LSX,LSX/A	
								LXQ4,LXQ4/A,QAQ4,QKA2,QXU,QXU/A,SJC1,SJC1/A,SJC5,SJC5/A,SMS,SMS/A	
								SNC1,SNR/A,SXU,SXU/A,VXP,VXQP,VXU,VXU/A,VXU1	
								HAQ,HA2,HXQ4,LX2,PA2,PMT2,QAQ2,QAQ,QA2,QXC9,QXQ4,RA2,RSC2,RTB2	
								RXQ4,SMX2,SXQ4,VA2,VH12,VTA,VWC2,VXQ4,WKT2	
								ETX	
								LNJ,LNZ,LSS5,LSS5/A	
10	35100-766-013	SWITCH ASSY., COMBINATION ...	1	-	-	3116815	3132285		
			1	-	-	-----	-----	LNJ,LNZ,LSS5,LSS5/A	
11	35110-766-003	KEY ASSY., COMBINATION SWITCH	2	-	-	-----	-----		
			2	-	-	4568916	-----	LNJ,LNZ,LSS5	
	35110-736-612	2	-	-	4568917	-----		
							LSS5/A		
12	35120-Z0D-V81	SWITCH ASSY., ENGINE STOP ...	1	-	-	-----	-----		
			1	-	-	-----	-----	QHB2	
	36100-ZE1-015	1	(1)	-	3566259	-----		
							ED5,HAQ,HA2,LX2,L1,PA2,PMT2,P1,QAQ2,QAQ,QA2,QKA2,QXC9,Q1,RA2,RSC2		
							RTB2,R1,SMX2,S1,VA2,VH12,VTA,VWC2,VXU,V1,WKT2,W1		
							ED4,ED4/A,EN,ES,HH,HTX,LD,LDB1,LDB3,LH,LH/A,LHZ,LJ,LJ/A,LJG,LJG/A		
							LJG1,LJS,LJS/A,LK,LM9,LP,LP/A,LT,LT/A,LW,QC12,QC12/A,QD,QD/A,QDA		
							QH,QH/A,QHC,QHP1,QHP1/A,QHZ,QMH,QMH/A,QP,QP/A,QT,QT/A,RD,RD/A,RH		
							RJ,RJ/A,SD,SD/A,SDB1,SDB3,SDB3/A,SH,SJ,SJ/A,SJC,SJG,SJG/A,SK,SMS		
							SMS/A,STP,STP/A,STQ,STQ/A,SW,VH,VH/A,WH,WJ,WJ/A,WMK		
			1	-	-	3313581	-----		
			1	-	-	3566459	-----		
			1	-	-	3116815	3313581		
			1	-	-	3116815	3566259		
			1	-	-	3116815	3566459		
			-	-	1	-----	1000005		
							VXP		
36100-ZH7-003	1	(1)	1	-----	-----		
									ED5/A,ES1/A,ES2,HX/A,LSX/A,LX/A,LX2/A,L1/A,PMT2/A,PX/A,QAB2
									QAB2/A,QAQ,QAQ/A,QAQ2/A,QA2/A,QMX2,QTC2,QTC2/A,QX/A,QXC/A,QXC9/A
									QXU,QXU/A,Q1/A,RTB2/A,RX/A,R1/A,SJC1/A,SJC5/A,SMX2/A,SNR/A, SX/A
									SXU,SXU/A,S1/A,VA2/A,VDG2,VDG2/A,VH12/A,VMT2,VMX,VTA2,VTA2/A,VX/A
									VXB/A,VXB7/VXB7/A,VXP/A,VXU/A,VXU1,VXU1/A,WKD6,WKD6/A,WKT2/A,W1/A
									ED5,ES1,HA,HAQ,HA2,HX,LX,LXZ,LX2,L1,PA,PA2,PMT2,PX,P1,QA,QAQ2,QAQ
									QA2,QKA2,QX,QXC,QXC9,Q1,RA,RA2,RSC2,RTB2,RX,R1,SMX2,SX,S1,VA,VAH1
									VA2,VH12,VNG,VTA,VWC2,VX,VXB,VXU,V1,WKT2,W1
						1	-	-	3566460
			1	-	-	4734391	-----		
			-	-	1	1000006	-----		
							VXP		
36100-ZH8-W41	1	-	-	-----	-----		
			1	-	-	3313582	-----	HHQ4,HHQ4/A,LSS4,QE/A,QHQ4,QHQ4/A,RHQ4,RHQ4/A,SE/A	
			1	-	-	-----	-----	QE,SE	
			1	-	-	3566259	-----	HXQ4,LXQ4,QAQ4,QXQ4,RXQ4,SNC1,SXQ4,VXQ4	
			1	-	-	3313582	-----	QXB,SXB	
			-	-	1	1000005	-----		
							VXQP		
			1	-	-	4734392	-----		
							HA2/A,PA2/A,RA2/A,VWC2/A		
13	81329-567-020	GROMMET, DRAIN HOLE	1	-	-	-----	-----		
									EDN,EDN2,EDN2/A,EDS,EDS1,EDS1/A,EDS2,EDS2/A,EDS3,EDS6,EDS6/A,EDT1
									EDT1/A,EDT2,EDT3,EDT6,EDT6/A,ED2,ED2/A,ED3,EN2,EN2/A,ES3,ES3/A,ET
									ETS,ETX,LHE,LHE4,LHE4/A,LKS,LKS/A,LM9,LNJ,LNZ,LSS5,LSS5/A,PAE,QAQ
									QAE2,QAE2/A,QAR2,QAR2/A,QHE,QXE,QXE/A,QXEB,QXE4,QXE4/A,RHE,RHE4
									RSS1,RSS1/A,SHE,SHEZ,SHW,SHW/A,SMS,SMS/A,SNE1,SWE,SXE,SXEB,SXE4
									SXE4/A, VSB1,VSB1/A,VS3,VS4,VTE2,VXE,VXE/A,VXEB,VXEB/A,WKA
									ES1,HA,HX,LX,LXZ,PA,PX,QA,QX,QXB,QXC,RA,RX,SJP,SNR,SX,SXB,VA,VAH1
									VNG,VX,VXB
						-	(1)	-	-----
			-	-	1	-----	VXQP		
	50317-254-000	PLUG, USELESS HOLE	-	-	-	-----	-----		



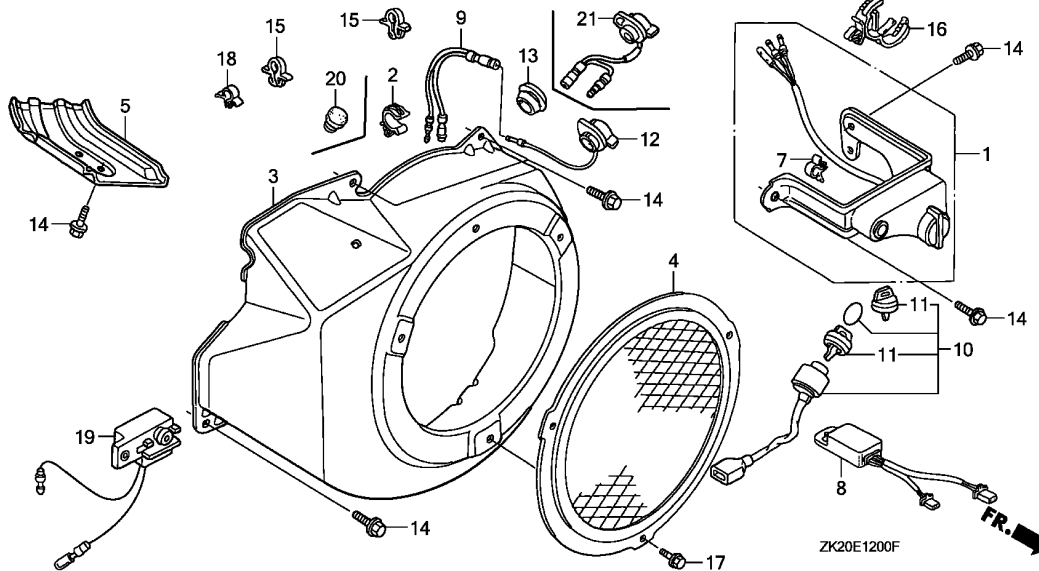

Ref. No.	Part No.	Description	Reqd. QTY			Serial No.	Parts catalogue code
			(1)	(2)	(3)		
			GX240K1				
14	90013-883-000	BOLT, FLANGE, 6X12(CT200) ...	8	8	-	3116814	ES1,HA,HX,LX,LXZ,L1,PA,PX,P1,QA,QX,QXB,QXC,Q1,RA,RX,R1,SJP,SNR,SX SXB,S1,VA,VAH1,VNG,VX,VXB,V1,W1
			6	6	-		EDN,EDN2,EDN2/A,EDS,EDS1,EDS1/A,EDS2,EDS2/A,EDS3,EDS6,EDS6/A,EDT1 EDT1/A,EDT2,EDT3,EDT6,EDT6/A,ED2,ED2/A,ED3,ED4,ED4/A,ED5,ED5/A,EN EN2,EN2/A,ES,ES1/A,ES2,ES3,ES3/A,ET,ETS,ETX,HAQ,HA2,HA2/A,HH,HHQ4 HHQ4/A,HTX,HX/A,HXQ4,HXQ4/A,LD,LDB1,LDB3,LH,LH/A,LHE,LHE4,LHE4/A LHZ,LJ,LJ/A,LJG,LJG/A,LJG1,LJS,LJS/A,LK,LKS,LKS/A,LM9,LNJ,LNZ,LP LP/A,LSS4,LSS5,LSS5/A,LSX,LSX/A,LT,LT/A,LW,LX/A,LXF,LXQ4,LXQ4/A LX2,LX2/A,L1/A,PAE,PA2,PA2/A,PMT2,PMT2/A,PX/A,QAB2,QAB2/A,QAE QAE2,QAE2/A,QAG,QAG/A,QAG2,QAG2/A,QAQ,QAQ4,QAR2,QAR2/A,QA2,QA2/A QC12,QC12/A,QD,QD/A,QDA,QE,QE/A,QH,QH/A,QHB2,QHC,QHE,QHP1,QHP1/A QHQ4,QHQ4/A,QHZ,QKA2,QMH,QMH/A,QMX2,QP,QP/A,QT,QT/A,QTC2,QTC2/A QW24,QX/A,QXB7,QXB7/A,QXC/A,QXC9,QXC9/A,QXE,QXE/A,QXEB,QXE4 QXE4/A,QXQ4,QXQ4/A,QXU,QXU/A,Q1/A,RA2,RA2/A,RD,RD/A,RH,RHE,RHE4 RHQ4,RHQ4/A,RJ,RJ/A,RSC2,RSS1,RSS1/A,RTB2,RTB2/A,RX/A,RXQ4,RXQ4/A R1/A,SD,SD/A,SDB1,SDB3,SDB3/A,SE,SE/A,SH,SHE,SHEZ,SHW,SHW/A,SJ SJ/A,SJC,SJC1,SJC1/A,SJC5,SJC5/A,SJG,SJG/A,SK,SMS,SMS/A,SMX2 SMX2/A,SNC1,SNE1,SNR/A,STP,STP/A,STQ,STQ/A,SW,SWE,SX/A,SXE,SXEB SXE4,SXE4/A,SXQ4,SXQ4/A,SXU,SXU/A,S1/A,VA2,VA2/A,VDG2,VDG2/A,VH VH/A,VH12,VH12/A,VMT2,VMX,VS1,VS1/A,VS3,VS4,VTA,VTA2,VTA2/A VTE2,VWC2,VWC2/A,VX/A,VXB/A,VXB7,VXB7/A,VXE,VXE/A,VXEB,VXEB/A VXQ4,VXQ4/A,VXQ7,VXQ7/A,VXU,VXU/A,VXU1,VXU1/A,WH,WJ,WJ/A,WKA,WKD6 WKD6/A,WKT2,WKT2/A,WKT4,WKT4/A,WMK,W1/A
			6	6	-	3116815	ES1,HA,HX,LX,LXZ,L1,PA,PX,P1,QA,QX,QXB,QXC,Q1,RA,RX,R1,SJP,SNR,SX SXB,S1,VA,VAH1,VNG,VX,VXB,V1,W1
15	90654-SA4-003	CLIP, WIRE HARNESS, 6MM(WHITE)	1	-	-		EDN,EDS,EDS1,EDS3,EDT1,ED2,ES3,VS1,VTE2
			2	-	-		EDN2,EDN2/A,EDS1/A,EDS2,EDS2/A,EDS6,EDS6/A,EDT1/A,EDT2,EDT3,EDT6 EDT6/A,ED2/A,EN2,EN2/A,ES3/A,VS1/A,VS3,VS4

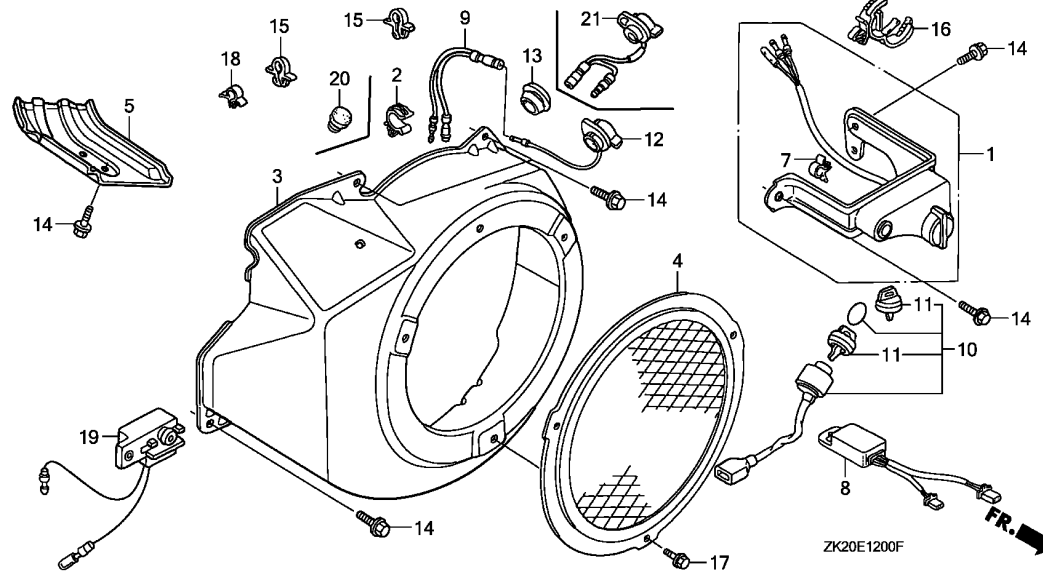

Ref. No.	Part No.	Description	Reqd. QTY			Serial No.	Parts catalogue code
			(1)	(2)	(3)		
16	90684-ZA0-601	CLIP, HARNESS	1	-	-	-----	ED2/A,ED5,ED5/A,EN2,EN2/A,ES1,ES1/A,HA,HAQ,HA2,HA2/A,HX,HX/A,LX LX/A,LXZ,LX2,LX2/A,PA,PA2,PA2/A,PMT2,PMT2/A,PX,PX/A,QA,QAG,QAG/A QAG2,QAG2/A,QAQ,QA2,QA2/A,QW24,QX,QX/A,QXB,QXB7,QXB7/A,QXC,QXC/A QXC9,QXC9/A,QXU,QXU/A,RA,RA2,RA2/A,RSC2,RX,RX/A,SJP,SMX2,SMX2/A SNR,SNR/A,SX,SX/A,SXB,SXU,SXU/A,VA,VAH1,VA2,VA2/A,VH12,VH12/A,VNG VTA,VTA2,VTA2/A,VX,VX/A,VXB,VXB/A,VXB7,VXB7/A,VXQ7,VXQ7/A,VXU VXU/A,VXU1,VXU1/A,WKT2,WKT2/A
			1	-	-	3132286	ED2,ETX
17	95701-06008-00	BOLT, FLANGE, 6X8	3	-	-	-----	LNJ
	90008-ZE2-003	BOLT, FLANGE, 6X10	3	-	-	-----	LKS,LKS/A,SHW,SHW/A
18	36103-ZE1-000	HOLDER, STOP SWITCH CORD	1	-	-	-----	LJS,LJS/A,QC12,QC12/A,QHB2
19	15520-ZB2-003	ALERT UNIT, OIL	1	-	-	3116815	ES3
20	50317-254-000	PLUG, USELESS HOLE	-	-	1	-----	VXP,VXP/A
21	36100-ZH7-W41	SWITCH ASSY., ENGINE STOP	1	-	-	-----	HXQ4/A,LXQ4/A,QXB7,QXB7/A,QXQ4/A,RXQ4/A,SXQ4/A,VXQ4/A,VXQ7,VXQ7/A WKT4,WKT4/A
			1	-	-	3566260	HXQ4,LXQ4,QAQ4,QXB,QXQ4,RXQ4,SNC1,SXB,SXQ4,VXQ4
			-	-	1	1000006	VXQP
	36100-ZH7-003	1	-	-	-----	LXF
	36100-ZF6-P81	1	-	-	-----	QW24

E-12-1

FAN COVER(2)

I13

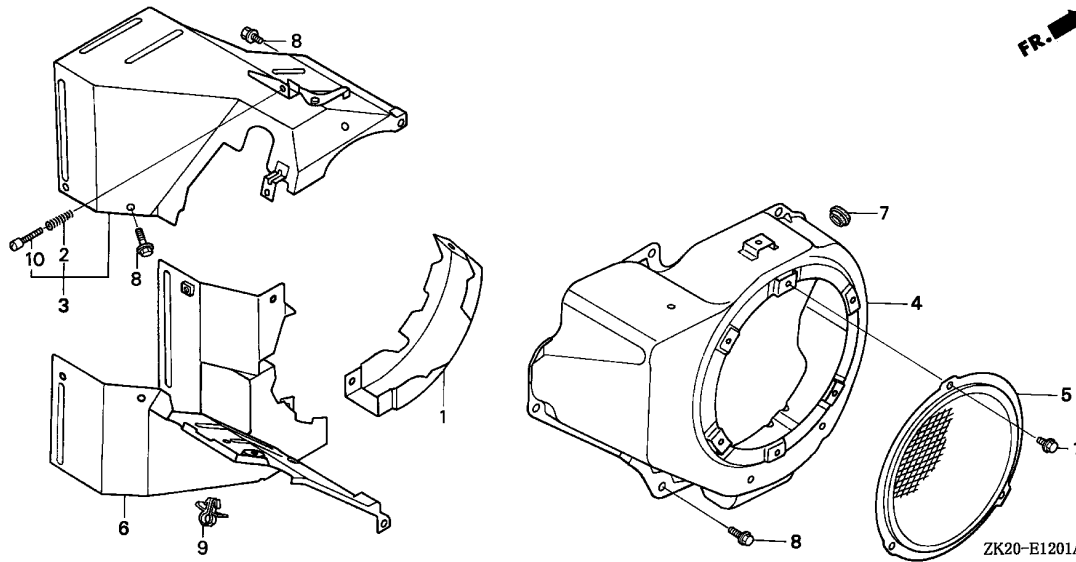

Ref. No.	L.O.N.	(Relative ref. Number) Description	F.R.T.
3	4141E2	SHROUD, ENGINE :UPPER	0.3
4	1141G8	COVER, ENGINE COOLING FAN	0.2
6	4141E0	SHROUD, ENGINE :LOWER	0.3

2

Ref. No.	Part No.	Description	Reqd. QTY			Serial No.	Parts catalogue code
			(1)	(2)	(3)		
			GX240K1				
1	11315-ZB7-000	SCROLL, GENERATOR FAN	1	-	-	-----	EDS5
2	16584-883-300	SPRING, CONTROL ADJUSTING ...	1	-	-	-----	EDS5
3	19602-ZE2-E10	SHROUD ASSY., UPPER	1	-	-	-----	EDS5
4	19610-ZB7-000	COVER COMP., FAN	1	-	-	-----	EDS5
5	19620-ZE2-000ZA	PROTECTOR COMP., FAN COVER *R8*.....BRIGHT RED	1	-	-	-----	EDS5
6	19640-ZE2-E10	SHROUD COMP., LOWER	1	-	-	-----	EDS5
7	81329-567-020	GROMMET, DRAIN HOLE	1	-	-	-----	EDS5
8	90013-883-000	BOLT, FLANGE, 6X12(CT200) ...	7	-	-	-----	EDS5
9	90654-SA4-003	CLIP, WIRE HARNESS, 6MM(WHITE)	1	-	-	-----	EDS5
10	93500-05032-0A	SCREW, PAN, 5X32	1	-	-	-----	EDS5
11	95701-06008-00	BOLT, FLANGE, 6X8	3	-	-	-----	EDS5

E-14

CARBURETOR(1)

I14

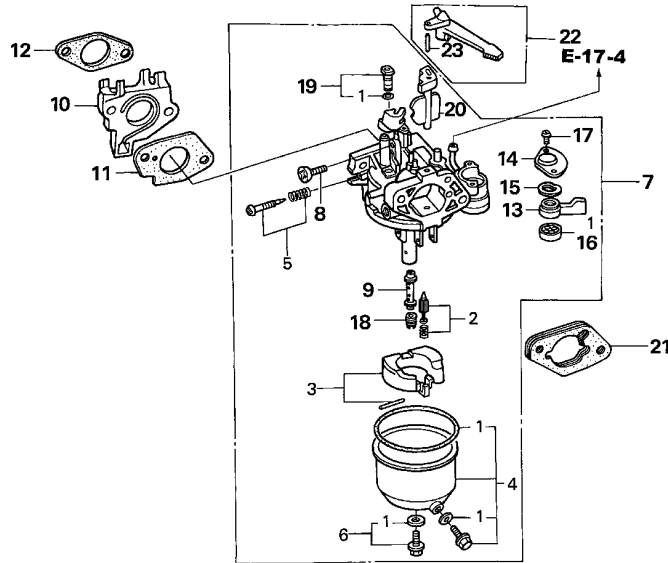

Ref. No.	L.O.N.	(Relative ref. Number) Description	F.R.T.
1	3111B1	GASKET SET, CARBURETOR	0.3
2	3111E1	VALVE SET, FLOAT AND/OR FLOAT SET	0.3
4	3111A3	CHAMBER SET, FLOAT AND/OR GASKET, FLOAT CHAMBER	0.2
5	3111D7	SCREW SET, PILOT	0.2
7	3111F3	CARBURETOR	0.2
10	3111C0	INSULATOR, CARBURETOR AND/OR PACKING, INSULATOR	0.2
11	3111C8	PACKING, CARBURETOR	0.2
16	3101C5	PACKING, FUEL COCK	0.2
18	3111C3	JET, MAIN	0.3
21	3111D9	SPACER, CARBURETOR	0.2
22	8101F9	LEVER, CARBURETOR CHOKE	0.2

Ref. No.	Part No.	Description	Reqd. QTY			Serial No.	Parts catalogue code
			(1)	(2)	(3)		
1	16010-ZE2-015	GASKET SET (EXCEPT 16173-001-004)	1	-	-	LD,LDB1,LDB3,QD,QD/A,RD,RD/A,SD,SD/A,SDB1,SDB3,SDB3/A,SNC1,WMK	
2	16011-ZA0-931	VALVE SET, FLOAT	1	-	-	LD,LDB1,LDB3,QD,QD/A,RD,RD/A,SD,SD/A,SDB1,SDB3,SDB3/A,SNC1,WMK	
3	16013-ZA0-931	FLOAT SET	1	-	-	LD,LDB1,LDB3,QD,QD/A,RD,RD/A,SD,SD/A,SDB1,SDB3,SDB3/A,SNC1,WMK	
4	16015-ZE8-005	CHAMBER SET, FLOAT	1	-	-	LD,LDB1,LDB3,QD,QD/A,RD,RD/A,SD,SD/A,SDB1,SDB3,SDB3/A,SNC1,WMK	
5	16016-ZE0-005	SCREW SET, PILOT	1	-	-	LD,LDB1,LDB3,QD,QD/A,RD,RD/A,SD,SD/A,SDB1,SDB3,SDB3/A,SNC1,WMK	
6	16028-ZE0-005	SCREW SET	1	-	-	LD,LDB1,LDB3,QD,QD/A,RD,RD/A,SD,SD/A,SDB1,SDB3,SDB3/A,SNC1,WMK	
7	16100-ZE2-W20 16100-ZE2-W21	CARBURETOR ASSY. (BE15F A) CARBURETOR ASSY. (BE15F B)	1 1	(1) (1)	-	3455474 LD,LDB1,LDB3,L1,P1,QD,Q1,RD,R1,SD,SDB1,SDB3,SNC1,S1,V1,W1 L1/A,QD/A,Q1/A,RD/A,R1/A,SD/A,SDB3/A,S1/A,WMK,W1/A	
8	16124-ZE0-005	SCREW, THROTTLE STOP	1	-	-	3455475 LD,LDB1,LDB3,L1,P1,QD,Q1,RD,R1,SD,SDB1,SDB3,SNC1,S1,V1,W1	
9	16166-ZE2-015	NOZZLE, MAIN	1	-	-	LD,LDB1,LDB3,QD,QD/A,RD,RD/A,SD,SD/A,SDB1,SDB3,SDB3/A,SNC1,WMK	
10	16211-ZE2-000	INSULATOR, CARBURETOR	1	-	-	LD,LDB1,LDB3,QD,QD/A,RD,RD/A,SD,SD/A,SDB1,SDB3,SDB3/A,SNC1,WMK	
11	16221-ZA0-800	PACKING, CARBURETOR	1	-	-	LD,LDB1,LDB3,QD,QD/A,RD,RD/A,SD,SD/A,SDB1,SDB3,SDB3/A,SNC1,WMK	
12	16223-ZA0-800	PACKING, INSULATOR	1	-	-	LD,LDB1,LDB3,QD,QD/A,RD,RD/A,SD,SD/A,SDB1,SDB3,SDB3/A,SNC1,WMK	



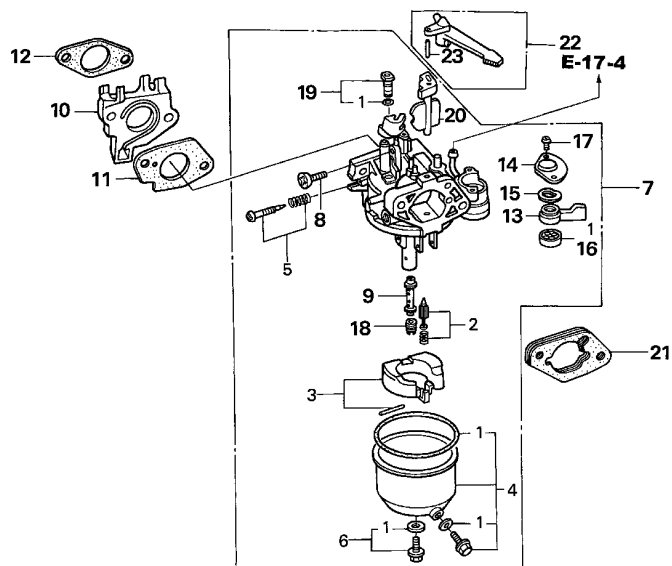

ZK20-E1400C



Ref. No.	Part No.	Description	Reqd. QTY			Serial No.	Parts catalogue code
			GX240K1				
			(1)	(2)	(3)		
13	16953-ZE1-811	LEVER, COCK (CARBURETOR NO.)	1	(1)	-	BE15F A LD,LDB1,LDB3,L1,P1,QD,Q1,RD,R1,SD,SDB1,SDB3,SNC1,S1,V1,W1	
	16953-ZE1-812	(CARBURETOR NO.)	1	-	-	QD/A,RD/A,SD/A,SDB3/A,WMK	
		(CARBURETOR NO.)	1	-	-	LD,LDB1,LDB3,QD,RD,SD,SDB1,SDB3,SNC1	
14	16954-ZE1-812	PLATE, LEVER SETTING	1	-	-	LD,LDB1,LDB3,QD,QD/A,RD,RD/A,SD,SD/A,SDB1,SDB3,SDB3/A,SNC1,WMK	
			-	(1)	-		
15	16956-ZE1-811	SPRING, COCK LEVER	1	-	-	LD,LDB1,LDB3,QD,QD/A,RD,RD/A,SD,SD/A,SDB1,SDB3,SDB3/A,SNC1,WMK	
			-	(1)	-		
16	16957-ZE1-812	PACKING, FUEL COCK	1	-	-	LD,LDB1,LDB3,QD,QD/A,RD,RD/A,SD,SD/A,SDB1,SDB3,SDB3/A,SNC1,WMK	
			-	(1)	-		
17	93500-03008-1G	SCREW, PAN, 3X8 (CARBURETOR NO.)	2	(2)	-	BE15F A LD,LDB1,LDB3,L1,P1,QD,Q1,RD,R1,SD,SDB1,SDB3,SNC1,S1,V1,W1	
	93500-03006-1H	SCREW, PAN, 3X6 (CARBURETOR NO.)	2	-	-	QD/A,RD/A,SD/A,SDB3/A,WMK	
		(CARBURETOR NO.)	2	-	-	LD,LDB1,LDB3,QD,RD,SD,SDB1,SDB3,SNC1	
			-	(2)	-	BE15F B	
18	99101-ZF5-0800	JET, MAIN, #80 (CARBURETOR NO.)	(1)	(1)	-	BE15F A LD,LDB1,LDB3,L1,P1,QD,Q1,RD,R1,SD,SDB1,SDB3,SNC1,V1,W1	
	99101-ZF5-0820	JET, MAIN, #82 (CARBURETOR NO.)	(1)	(1)	-	BE15F A LD,LDB1,LDB3,L1,P1,QD,Q1,RD,R1,SD,SDB1,SDB3,SNC1,V1,W1	
	99101-ZF5-0850	JET, MAIN, #85 (CARBURETOR NO.)	1	(1)	-	BE15F A LD,LDB1,LDB3,L1,P1,QD,Q1,RD,R1,SD,SDB1,SDB3,SNC1,V1,W1	
	99101-ZH8-0800	JET, MAIN, #80 (CARBURETOR NO.)	(1)	(1)	-	L1/A,QD/A,Q1/A,RD/A,R1/A,SD/A,SDB3/A,S1/A,WMK,W1/A	
		(CARBURETOR NO.)	(1)	(1)	-	LD,LDB3,L1,QD,Q1,RD,R1,SD,SDB1,SDB3,S1,W1	
	99101-ZH8-0820	JET, MAIN, #82 (CARBURETOR NO.)	(1)	(1)	-	L1/A,QD/A,Q1/A,RD/A,R1/A,SD/A,SDB3/A,S1/A,WMK,W1/A	
		(CARBURETOR NO.)	(1)	(1)	-	LD,LDB3,L1,QD,Q1,RD,R1,SD,SDB1,SDB3,S1,W1	
	99101-ZH8-0850	JET, MAIN, #85 (CARBURETOR NO.)	1	1	-	L1/A,QD/A,Q1/A,RD/A,R1/A,SD/A,SDB3/A,S1/A,WMK,W1/A	
		(CARBURETOR NO.)	1	1	-	LD,LDB3,L1,QD,Q1,RD,R1,SD,SDB1,SDB3,S1,W1	

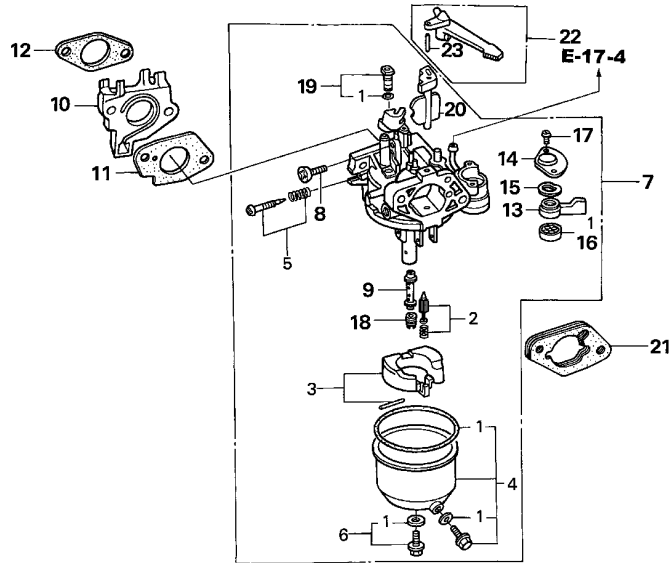

Ref. No.	Part No.	Description	Reqd. QTY			Serial No.	Parts catalogue code
			GX240K1				
			(1)	(2)	(3)		
19	99204-ZE2-0380	JET SET, PILOT, #38	1	(1)	-	-----	BE15F A LD,LDB1,LDB3,L1,P1,QD,Q1,RD,R1,SD,SDB1,SDB3,SNC1,S1,V1,W1
	99204-ZE0-0380	(CARBURETOR NO.)	1	-	-	-----	QD/A,RD/A,SD/A,SDB3/A,WMK
		(CARBURETOR NO.)	1	-	-	BE15F B	LD,LDB1,LDB3,QD,RD,SD,SDB1,SDB3,SNC1
			-	(1)	-	BE15F B	
20	16044-ZE2-005	CHOKE SET	1	-	-	-----	LD,LDB1,LDB3,QD,QD/A,RD,RD/A,SD,SD/A,SDB1,SDB3,SDB3/A,SNC1,WMK
			-	(1)	-		
21	16220-ZA0-702	SPACER COMP., CARBURETOR	1	(1)	-	-----	LD,LDB1,LDB3,L1,L1/A,P1,QD,QD/A,Q1,Q1/A,RD,RD/A,R1,R1/A,SD,SD/A,SDB1,SDB3,SDB3/A,SNC1,V1,WMK,W1,W1/A
22	16610-ZE1-000	LEVER COMP., CHOKE (STD.) ...	1	(1)	-	-----	LD,LDB1,LDB3,L1,L1/A,P1,QD,QD/A,Q1,Q1/A,RD,RD/A,R1,R1/A,SD,SD/A,SDB1,SDB3,SDB3/A,SNC1,V1,WMK,W1,W1/A
23	94305-20122	PIN, SPRING, 2X12	1	(1)	-	-----	LD,LDB1,LDB3,L1,L1/A,P1,QD,QD/A,Q1,Q1/A,RD,RD/A,R1,R1/A,SD,SD/A,SDB1,SDB3,SDB3/A,SNC1,V1,WMK,W1,W1/A



E-14-1

CARBURETOR(2)

J 1

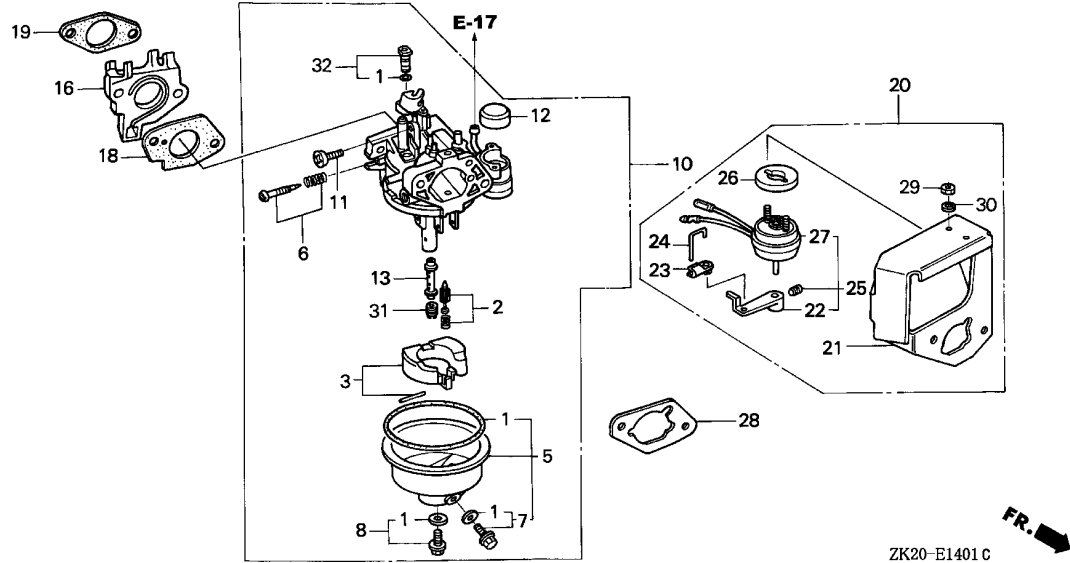

Ref. No.	L.O.N.	(Relative ref. Number) Description	F.R.T.
1	3111B1	GASKET SET, CARBURETOR	0.3
2	3111E1	VALVE SET, FLOAT AND/OR FLOAT SET	0.3
5	3111A3	CHAMBER SET, FLOAT AND/OR GASKET, FLOAT CHAMBER	0.2
6	3111D7	SCREW SET, PILOT	0.2
10	3111F3	CARBURETOR	0.2
16	3111C0	INSULATOR, CARBURETOR AND/OR PACKING, INSULATOR	0.2
18	3111C8	PACKING, CARBURETOR	0.2
20	8101BH	STAY ASSEMBLY, ROTARY CHOKE SOLENOID	0.2
22	8101F9	LEVER, CARBURETOR CHOKE	0.2
25	3111M0	SOLENOID, CARBURETOR CHOKE ...	0.2
27	8101R0	SOLENOID, ROTARY CHOKE	0.2
28	3121D9	PACKING, AIR CLEANER	0.2
31	3111C3	JET, MAIN	0.3

Ref. No.	Part No.	Description	Reqd. QTY			Serial No.	Parts catalogue code
			(1)	(2)	(3)		
			GX240K1				
1	16010-ZF5-900	GASKET SET	1	-	-	-----	WKA
2	16011-ZA0-931	VALVE SET, FLOAT	1	-	-	-----	WKA
3	16013-ZA0-931	FLOAT SET	1	-	-	-----	WKA
5	16015-ZE8-005	CHAMBER SET, FLOAT	1	-	-	-----	WKA
6	16016-ZE0-005	SCREW SET, PILOT	1	-	-	-----	WKA
7	16024-ZE1-811	SCREW SET, DRAIN	1	-	-	-----	WKA
8	16028-ZE0-005	SCREW SET	1	-	-	-----	WKA
10	16100-ZE2-V40	CARBURETOR ASSY. (BE19B A) ..	1	-	-	3467826	WKA
	16100-ZE2-V41	CARBURETOR ASSY. (BE19B B) ..	1	-	-	3467827	WKA
11	16124-ZE0-005	SCREW, THROTTLE STOP	1	-	-	-----	WKA
12	16148-141-881	CAP, CHOKE DUST	1	-	-	-----	WKA
13	16166-ZE2-015	NOZZLE, MAIN	1	-	-	-----	WKA
16	16211-ZE2-000	INSULATOR, CARBURETOR	1	-	-	-----	WKA
18	16221-ZA0-700	PACKING, CARBURETOR	1	-	-	3151974	WKA
	16221-ZA0-800	1	-	-	3151975	WKA
19	16223-ZA0-700	PACKING, INSULATOR	1	-	-	3151974	WKA
	16223-ZA0-800	1	-	-	3151975	WKA
20	16260-ZB7-000	STAY ASSY., SOLENOID	1	-	-	-----	WKA
21	16261-ZB7-000	STAY COMP., CHOKE SOLENOID ..	1	-	-	-----	WKA
22	16262-ZB7-000	LEVER, CHOKE SOLENOID	1	-	-	-----	WKA
23	16263-ZA0-000	JOINT, ROD	1	-	-	-----	WKA
24	16264-ZB7-000	ROD, CHOKE SOLENOID	1	-	-	-----	WKA
25	16265-ZB7-000	SOLENOID ASSY., CHOKE	1	-	-	-----	WKA
26	16266-ZB7-000	SPACER, CHOKE SOLENOID	1	-	-	-----	WKA
27	16267-ZB7-003	SOLENOID, ROTARY CHOKE	1	-	-	-----	WKA

2

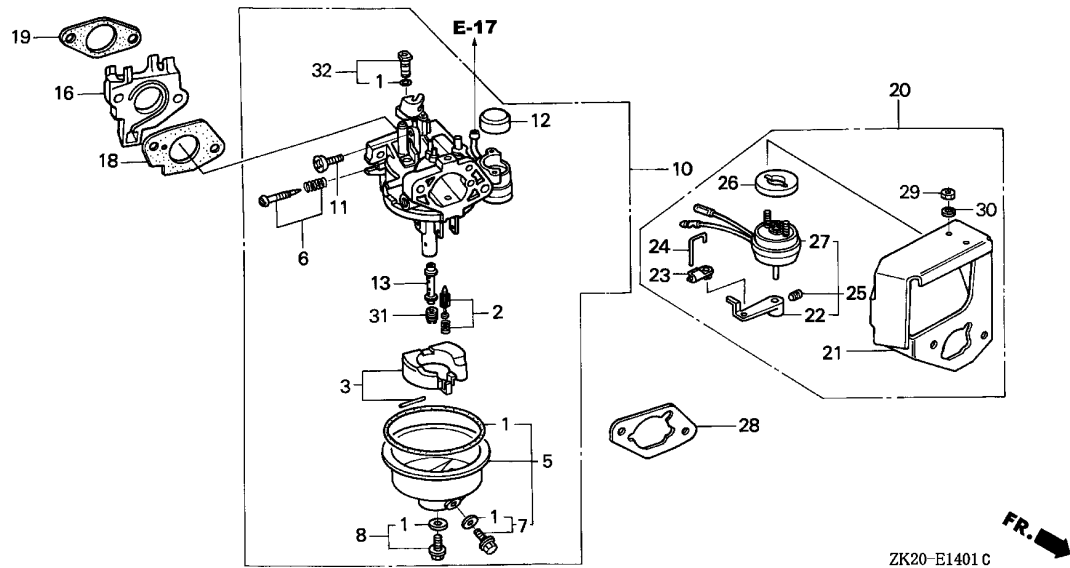

Ref. No.	Part No.	Description	Reqd. QTY			Serial No.	Parts catalogue code
			GX240K1				
			(1)	(2)	(3)		
28	16269-ZA0-800	PACKING, AIR CLEANER	2	-	-	-----	WKA
29	94001-03000-0S	NUT, HEX., 3MM	2	-	-	-----	WKA
30	94111-03800	WASHER, SPRING, 3MM	2	-	-	-----	WKA
31	99101-ZF5-0780	JET, MAIN, #78	(1)	-	-	-----	BE19B A WKA
	(CARBURETOR NO.)						
	99101-ZF5-0800	JET, MAIN, #80	(1)	-	-	-----	BE19B A WKA
	(CARBURETOR NO.)						
	99101-ZF5-0820	JET, MAIN, #82	1	-	-	-----	BE19B A WKA
	(CARBURETOR NO.)						
	99101-ZH8-0780	JET, MAIN, #78	(1)	-	-	BE19B B	----- WKA
	(CARBURETOR NO.)						
	99101-ZH8-0800	JET, MAIN, #80	(1)	-	-	BE19B B	----- WKA
	(CARBURETOR NO.)						
	99101-ZH8-0820	JET, MAIN, #82	1	-	-	BE19B B	----- WKA
	(CARBURETOR NO.)						
32	99204-ZE0-0450	JET SET, PILOT, #45	1	-	-	-----	WKA



E-14-2

CARBURETOR(3)

J 3

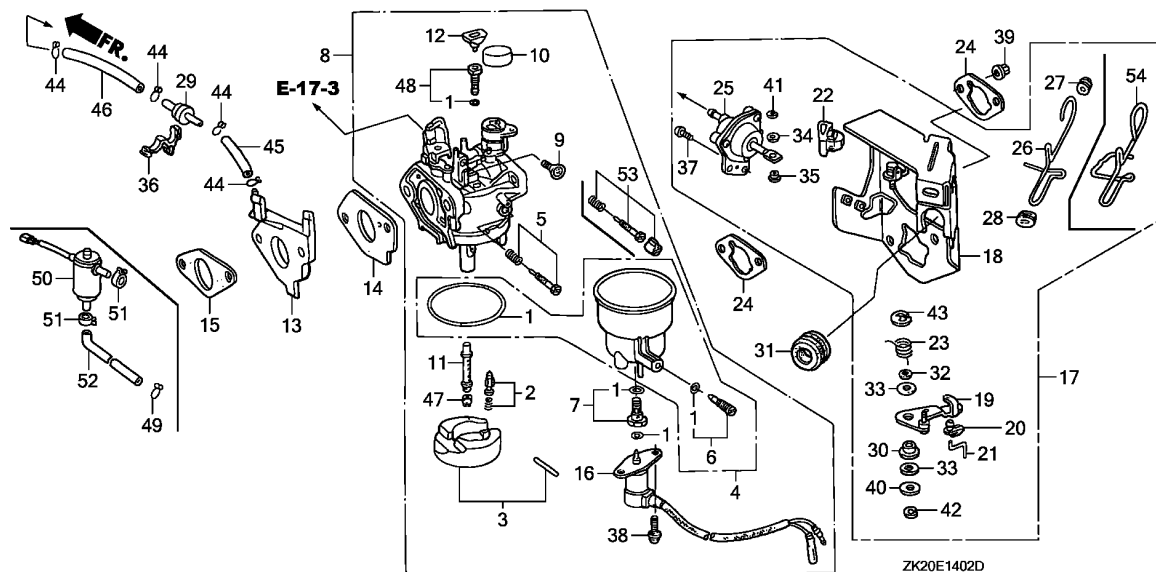

Ref. No.	L.O.N.	(Relative ref. Number) Description	F.R.T.
1	3111G1	GASKET SET, CARBURETOR(A) (3)	0.4
2	3111G6	VALVE SET, FLOAT AND/OR FLOAT SET(A)	0.4
4	3111M2	CHAMBER SET, FLOAT AND/OR GASKET, FLOAT CHAMBER(A) (53)	0.3
5	3111D7	SCREW SET, PILOT	0.2
8	3111G7	CARBURETOR(A) (15)	0.3
13	3111G2	INSULATOR, CARBURETOR AND/OR PACKING, INSULATOR(A)	0.3
14	3111G5	PACKING, CARBURETOR(A)	0.3
16	6211C0	VALVE, CARBURETOR SOLENOID	0.3
17	8101R1	STAY, MANUAL CHOKE	0.3
18	3111G3	STAY, CHOKE CONTROL	0.4
21	8101J8	ROD, CARBURETOR CHOKE	0.2
24	3121H2	PACKING, AIR CLEANER(A)	0.3
.NOTE: Same time for two units			
25	3111A7	DIAPHRAGM, CARBURETOR	0.3
29	311175	VALVE, DASHPOT CHECK	0.1
47	3111G4	JET, MAIN(A)	0.4

Ref. No.	Part No.	Description	Reqd. QTY			Serial No.	Parts catalogue code
			(1)	(2)	(3)		
1	16010-ZE3-701	GASKET SET	1	-	-	EDN,EDN2,EDN2/A,EDS,EDS1,EDS1/A,EDS2,EDS2/A,EDS3,EDS6,EDS6/A,EDT1/A,EDT2,EDT3,EDT6,EDT6/A,ED2,ED2/A,EN2,EN2/A,ES3,ES3/A,VMT2	
2	16011-ZA0-931	VALVE SET, FLOAT	1	-	-	VSB1,VSB1/A,VS3,VS4,VTE2	
3	16013-ZA0-931	FLOAT SET	1	-	-	EDN,EDN2,EDN2/A,EDS,EDS1,EDS1/A,EDS2,EDS2/A,EDS3,EDS6,EDS6/A,EDT1/A,EDT2,EDT3,EDT6,EDT6/A,ED2,ED2/A,EN2,EN2/A,ES3,ES3/A,VMT2	
4	16015-ZA0-931	CHAMBER SET, FLOAT	1	-	-	VSB1,VSB1/A,VS3,VS4,VTE2	
5	16016-ZE0-005	SCREW SET, PILOT (CARBURETOR NO.)	1	-	-	EDS	
		..	1	-	-	BE20B A ED2	
		..	1	-	-	BE20B B EDN,EDS1,EDS3,EDT1,ES3,VSB1	
6	16024-124-761	SCREW SET, DRAIN (CARBURETOR NO.)	1	-	-	EDN,EDN2,EDN2/A,EDS,EDS1,EDS2,EDS2/A,EDS3,EDS6,EDS6/A,EDT1,EDT2	
	16024-124-760	.. (CARBURETOR NO.)	1	-	-	EDT6,EDT6/A,ED2,ED2/A,EN2,EN2/A,ES3,VMT2,VSB1,VTE2	
		..	1	-	-	EDT3,VS4	
7	16028-ZA0-931	SCREW SET	1	-	-	BE72L A EDS1/A,EDT1/A,ES3/A,VSB1/A,VS3	
8	16100-ZE2-D00	CARBURETOR ASSY. (BE20B A)	1	-	-	EDN,EDN2,EDN2/A,EDS,EDS1,EDS1/A,EDS2,EDS2/A,EDS3,EDS6,EDS6/A,EDT1/A,EDT2,EDT3,EDT6,EDT6/A,ED2,ED2/A,EN2,EN2/A,ES3,ES3/A,VMT2	3337056 ED2
	16100-ZE2-D01	CARBURETOR ASSY. (BE20B B)	1	-	-	EDS	3453415 EDN,EDS,EDS1,EDS3,EDT1,ES3
		..	1	-	-	VSB1	3860624 VSB1
		..	1	-	-	EDN,EDS1,EDS3,EDT1,ES3	3453416 3860624 EDN,EDS1,EDS3,EDT1,ES3

Ref. No.	Part No.	Description	Reqd. QTY			Serial No.	Parts catalogue code
			(1)	(2)	(3)		
(8)	16100-ZE2-F00	CARBURETOR ASSY. (BE72C A) ..	1	-	-	3456694	EDN2
			1	-	-	3337057	3456694 ED2
	16100-ZE2-F01	CARBURETOR ASSY. (BE72C B) ..	1	-	-		EDS2,EDS6,EDT2,EDT6,EN2,VTE2
			1	-	-	3456695	EDN2,ED2
			1	-	-	3860625	EDN,EDS1,EDS3,EDT1,ES3,VS3
			1	-	-	4795055	EDS1/A,EDT1/A,ES3/A,VS3
			1	-	-	4796682	EDN2/A,EDS2/A,EDS6/A,EDT6/A,ED2/A,EN2/A,VMT2
	16100-ZE2-F02	CARBURETOR ASSY. (BE72C C) ..	1	-	-	4796683	EDN2/A,EDS2/A,EDS6/A,EDT6/A,ED2/A,EN2/A,VMT2
	16100-Z5F-F01	CARBURETOR ASSY. (BE72L A) ..	1	-	-		EDT3,VS4
			1	-	-	4795056	EDS1/A,EDT1/A,ES3/A,VS3
9	16124-ZE0-005	SCREW, THROTTLE STOP	1	-	-		EDN,EDN2,EDN2/A,EDS,EDS1,EDS1/A,EDS2,EDS2/A,EDS3,EDS6,EDS6/A,EDT1,EDT1/A,EDT2,EDT3,EDT6,EDT6/A,ED2,ED2/A,EN2,EN2/A,ES3,ES3/A,VMT2
							VS3,VS4,VTE2
10	16148-141-881	CAP, CHOKE DUST	1	-	-		EDN,EDN2,EDN2/A,EDS,EDS1,EDS1/A,EDS2,EDS2/A,EDS3,EDS6,EDS6/A,EDT1,EDT1/A,EDT2,EDT3,EDT6,EDT6/A,ED2,ED2/A,EN2,EN2/A,ES3,ES3/A,VMT2
							VS3,VS4,VTE2
11	16166-ZE2-015	NOZZLE, MAIN	1	-	-		EDN,EDN2,EDN2/A,EDS,EDS1,EDS1/A,EDS2,EDS2/A,EDS3,EDS6,EDS6/A,EDT1,EDT1/A,EDT2,EDT3,EDT6,EDT6/A,ED2,ED2/A,EN2,EN2/A,ES3,ES3/A,VMT2
							VS3,VS4,VTE2
12	16172-ZE3-W10	COLLAR, SETTING	1	-	-		EDN2,EDN2/A,EDS1/A,EDS2,EDS2/A,EDS3,EDS6,EDS6/A,EDT1/A,EDT2,EDT3,EDT6,EDT6/A,ED2/A,EN2,EN2/A,ES3/A,VMT2,VS3,VS4,VTE2
		(CARBURETOR NO.)	1	-	-	BE72C A	ED2
			1	-	-	BE72C B	EDN,EDS1,EDS3,EDT1,ES3,VS3
13	16211-ZE2-700	INSULATOR, CARBURETOR	1	-	-		EDN,EDN2,EDN2/A,EDS,EDS1,EDS1/A,EDS2,EDS2/A,EDS3,EDS6,EDS6/A,EDT1,EDT1/A,EDT2,EDT3,EDT6,EDT6/A,ED2,ED2/A,EN2,EN2/A,ES3,ES3/A,VMT2
							VS3,VS4,VTE2
14	16221-ZA0-800	PACKING, CARBURETOR	1	-	-		EDN,EDN2,EDN2/A,EDS,EDS1,EDS1/A,EDS2,EDS2/A,EDS3,EDS6,EDS6/A,EDT1,EDT1/A,EDT2,EDT3,EDT6,EDT6/A,ED2,ED2/A,EN2,EN2/A,ES3,ES3/A,VMT2
							VS3,VS4,VTE2
15	16223-ZA0-800	PACKING, INSULATOR	1	-	-		EDN,EDN2,EDN2/A,EDS,EDS1,EDS1/A,EDS2,EDS2/A,EDS3,EDS6,EDS6/A,EDT1,EDT1/A,EDT2,EDT3,EDT6,EDT6/A,ED2,ED2/A,EN2,EN2/A,ES3,ES3/A,VMT2
							VS3,VS4,VTE2
16	16230-ZE3-701	VALVE ASSY., SOLENOID	1	-	-		EDN,EDN2,EDN2/A,EDS,EDS1,EDS2,EDS2/A,EDS3,EDS6,EDS6/A,EDT1,EDT2,EDT6,EDT6/A,ED2,ED2/A,EN2,EN2/A,ES3,VMT2,VS3,VS4,VTE2
			1	-	-	4852917	EDS1/A,EDT1/A,ES3/A,VS3
	16230-ZE3-702	1	-	-		EDT3,VS4
			1	-	-	4852918	EDS1/A,EDT1/A,ES3/A,VS3
17	16260-ZE2-722	STAY ASSY., MANUAL CHOKE	1	-	-		EDN,EDN2,EDN2/A,EDS,EDS1,EDS1/A,EDS2,EDS2/A,EDS3,EDS6,EDS6/A,EDT1,EDT2,EDT6,EDT6/A,ED2,ED2/A,EN2,EN2/A,ES3,VS3,VS4,VTE2
			1	-	-	4852917	EDS1/A,EDT1/A,ES3/A,VS3
	16260-ZE3-D21	1	-	-		VMT2
	16260-ZE2-723	1	-	-		EDT3,VS4
			1	-	-	4852918	EDS1/A,EDT1/A,ES3/A,VS3
18	16261-ZE2-702	STAY COMP., SOLENOID	1	-	-		EDN,EDN2,EDN2/A,EDS,EDS1,EDS1/A,EDS2,EDS2/A,EDS3,EDS6,EDS6/A,EDT1,EDT1/A,EDT2,EDT3,EDT6,EDT6/A,ED2,ED2/A,EN2,EN2/A,ES3,ES3/A,VMT2
							VS3,VS4,VTE2
19	16262-ZE2-711	LEVER, CHOKE	1	-	-		EDN,EDN2,EDN2/A,EDS,EDS1,EDS1/A,EDS2,EDS2/A,EDS3,EDS6,EDS6/A,EDT1,EDT1/A,EDT2,EDT3,EDT6,EDT6/A,ED2,ED2/A,EN2,EN2/A,ES3,ES3/A,VMT2
							VS3,VS4,VTE2
20	16263-ZA0-000	JOINT, ROD	1	-	-		EDN,EDN2,EDN2/A,EDS,EDS1,EDS1/A,EDS2,EDS2/A,EDS3,EDS6,EDS6/A,EDT1,EDT1/A,EDT2,EDT3,EDT6,EDT6/A,ED2,ED2/A,EN2,EN2/A,ES3,ES3/A,VMT2
							VS3,VS4,VTE2
21	16264-ZE2-701	ROD, CHOKE	1	-	-		EDN,EDN2,EDN2/A,EDS,EDS1,EDS1/A,EDS2,EDS2/A,EDS3,EDS6,EDS6/A,EDT1,EDT1/A,EDT2,EDT3,EDT6,EDT6/A,ED2,ED2/A,EN2,EN2/A,ES3,ES3/A,VMT2
							VS3,VS4,VTE2



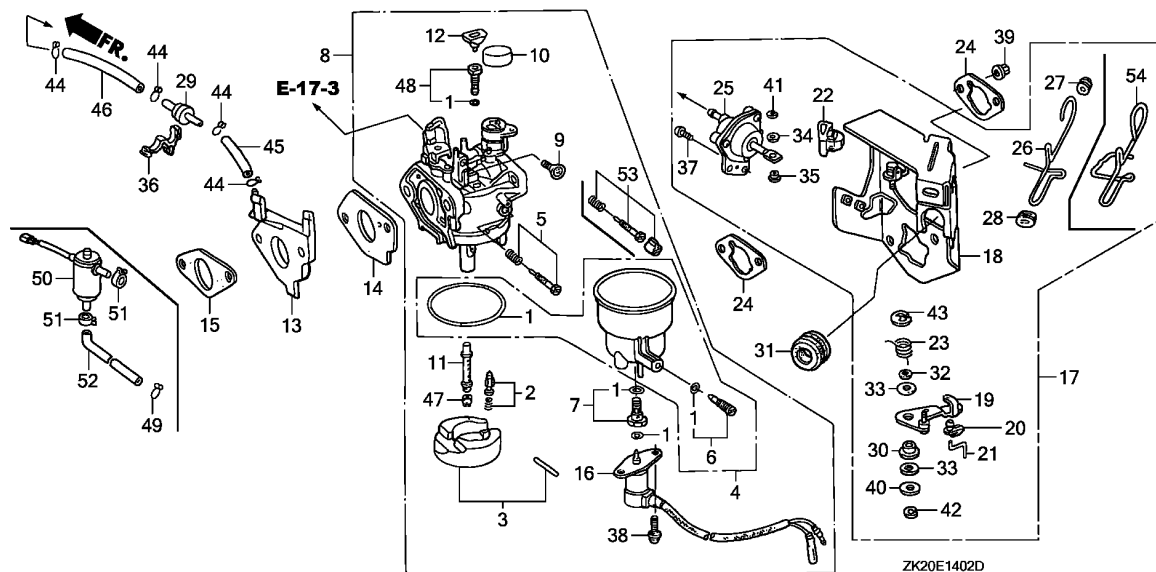

Ref. No.	Part No.	Description	Reqd. QTY			Serial No.	Parts catalogue code
			(1)	(2)	(3)		
22	16265-ZE2-721	STOPPER, CHOKE ROD	1	-	-	-	EDN,EDN2,EDN2/A,EDS,EDS1,EDS1/A,EDS2,EDS2/A,EDS3,EDS6,EDS6/A,EDT1/A,EDT2,EDT3,EDT6,EDT6/A,ED2,ED2/A,EN2,EN2/A,ES3,ES3/A,VMT2
23	16268-ZE2-721	SPRING, MANUAL CHOKE	1	-	-	-	EDN,EDN2,EDN2/A,EDS,EDS1,EDS1/A,EDS2,EDS2/A,EDS3,EDS6,EDS6/A,EDT1/A,EDT2,EDT3,EDT6,EDT6/A,ED2,ED2/A,EN2,EN2/A,ES3,ES3/A,VMT2
24	16269-ZA0-800	PACKING, AIR CLEANER	2	-	-	-	EDN,EDN2,EDN2/A,EDS,EDS1,EDS1/A,EDS2,EDS2/A,EDS3,EDS6,EDS6/A,EDT1/A,EDT2,EDT3,EDT6,EDT6/A,ED2,ED2/A,EN2,EN2/A,ES3,ES3/A,VMT2
25	16400-ZE2-703	DIAPHRAGM ASSY.	1	-	-	-	EDN,EDN2,EDN2/A,EDS,EDS1,EDS2,EDS2/A,EDS3,EDS6,EDS6/A,EDT1,EDT2
	16400-ZE2-704		1	-	-	4852917	EDS1/A,EDT1/A,ES3/A,VS3
			1	-	-		EDT3,VS4
			1	-	-	4852918	EDS1/A,EDT1/A,ES3/A,VS3
26	16611-ZE2-711	ROD, CHOKE CONTROL	1	-	-	-	EDN,EDN2,EDN2/A,EDS,EDS1,EDS1/A,EDS2,EDS2/A,EDS3,EDS6,EDS6/A,EDT1/A,EDT2,EDT3,EDT6,EDT6/A,ED2,ED2/A,EN2,EN2/A,ES3,ES3/A,VS3
27	16613-893-000	GROMMET, CHOKE ROD	1	-	-	-	EDN,EDN2,EDN2/A,EDS,EDS1,EDS1/A,EDS2,EDS2/A,EDS3,EDS6,EDS6/A,EDT1/A,EDT2,EDT3,EDT6,EDT6/A,ED2,ED2/A,EN2,EN2/A,ES3,ES3/A,VMT2
28	16615-893-000	GUIDE, CHOKE ROD	1	-	-	-	EDN,EDN2,EDN2/A,EDS,EDS1,EDS1/A,EDS2,EDS2/A,EDS3,EDS6,EDS6/A,EDT1/A,EDT2,EDT3,EDT6,EDT6/A,ED2,ED2/A,EN2,EN2/A,ES3,ES3/A,VMT2
29	36135-ZV1-003	VALVE, DASHPOT CHECK	1	-	-	3307577	EDN,EDS,EDS1,EDS3,EDT1,ED2,ES3
	36135-ZF6-D41		1	-	-		EDN2,EDN2/A,EDS1/A,EDS2,EDS2/A,EDS6,EDS6/A,EDT1/A,EDT2,EDT3,EDT6
			1	-	-	3307578	EDT6/A,ED2/A,EN2,EN2/A,ES3/A,VMT2,VS3,VS4,VTE2
			1	-	-		EDN,EDS,EDS1,EDS3,EDT1,ED2,ES3

Ref. No.	Part No.	Description	Reqd. QTY			Serial No.	Parts catalogue code
			GX240K1	(1)	(2)		
30	53149-964-003	BUSH, ARM PIVOT	1	-	-	-----	EDN,EDN2,EDN2/A,EDS,EDS1,EDS1/A,EDS2,EDS2/A,EDS3,EDS6,EDS6/A,EDT1,EDT1/A,EDT2,EDT3,EDT6,EDT6/A,ED2,ED2/A,EN2,EN2/A,ES3,ES3/A,VMT2, VSB1,VSB1/A,VS3,VS4,VTE2
31	88911-MJ3-000	GROMMET, FENDER	1	-	-	-----	EDN,EDN2,EDN2/A,EDS,EDS1,EDS1/A,EDS2,EDS2/A,EDS3,EDS6,EDS6/A,EDT1,EDT1/A,EDT2,EDT3,EDT6,EDT6/A,ED2,ED2/A,EN2,EN2/A,ES3,ES3/A,VMT2, VSB1,VSB1/A,VS3,VS4,VTE2
32	90431-ZE2-700	WASHER, CHOKE LEVER	1	-	-	-----	EDN,EDN2,EDN2/A,EDS,EDS1,EDS1/A,EDS2,EDS2/A,EDS3,EDS6,EDS6/A,EDT1,EDT1/A,EDT2,EDT3,EDT6,EDT6/A,ED2,ED2/A,EN2,EN2/A,ES3,ES3/A,VMT2, VSB1,VSB1/A,VS3,VS4,VTE2
33	90432-ZE2-700	SEAL, CHOKE LEVER	2	-	-	-----	EDN,EDN2,EDN2/A,EDS,EDS1,EDS1/A,EDS2,EDS2/A,EDS3,EDS6,EDS6/A,EDT1,EDT1/A,EDT2,EDT3,EDT6,EDT6/A,ED2,ED2/A,EN2,EN2/A,ES3,ES3/A,VMT2, VSB1,VSB1/A,VS3,VS4,VTE2
34	90433-ZE2-700	WASHER, THRUST, 2.7X8	1	-	-	-----	EDN,EDN2,EDN2/A,EDS,EDS1,EDS1/A,EDS2,EDS2/A,EDS3,EDS6,EDS6/A,EDT1,EDT1/A,EDT2,EDT3,EDT6,EDT6/A,ED2,ED2/A,EN2,EN2/A,ES3,ES3/A,VMT2, VSB1,VSB1/A,VS3,VS4,VTE2
35	90434-ZE2-700	COLLAR, LEVER	1	-	-	-----	EDN,EDN2,EDN2/A,EDS,EDS1,EDS1/A,EDS2,EDS2/A,EDS3,EDS6,EDS6/A,EDT1,EDT1/A,EDT2,EDT3,EDT6,EDT6/A,ED2,ED2/A,EN2,EN2/A,ES3,ES3/A,VMT2, VSB1,VSB1/A,VS3,VS4,VTE2
36	90650-SD9-003	CLIP, WIRE HARNESS	1	-	-	-----	EDN,EDN2,EDN2/A,EDS,EDS1,EDS1/A,EDS2,EDS2/A,EDS3,EDS6,EDS6/A,EDT1,EDT1/A,EDT2,EDT3,EDT6,EDT6/A,ED2,ED2/A,EN2,EN2/A,ES3,ES3/A,VMT2, VSB1,VSB1/A,VS3,VS4,VTE2
37	93500-05012-0A	SCREW, PAN, 5X12	2	-	-	-----	EDN,EDN2,EDN2/A,EDS,EDS1,EDS1/A,EDS2,EDS2/A,EDS3,EDS6,EDS6/A,EDT1,EDT1/A,EDT2,EDT3,EDT6,EDT6/A,ED2,ED2/A,EN2,EN2/A,ES3,ES3/A,VMT2, VSB1,VSB1/A,VS3,VS4,VTE2
38	93892-05012-08	SCREW-WASHER, 5X12	2	-	-	-----	EDS
		(CARBURETOR NO.)	2	-	-	-----	BE20B A ED2
	93892-05012-18	2	-	-	-----	BE20B B EDN,EDS1,EDS3,EDT1,ES3,VSB1
		(CARBURETOR NO.)	2	-	-	-----	EDN2,EDN2/A,EDS1/A,EDS2,EDS2/A,EDS6,EDS6/A,EDT1/A,EDT2,EDT3,EDT6,EDT6/A,ED2/A,EN2,EN2/A,ES3/A,VMT2,VSB1/A,VS3,VS4,VTE2
			2	-	-	-----	ED2
			2	-	-	-----	EDN,EDS1,EDS3,EDT1,ES3,VSB1
39	94050-06000	NUT, FLANGE, 6MM	2	-	-	-----	EDN,EDN2,EDN2/A,EDS,EDS1,EDS1/A,EDS2,EDS2/A,EDS3,EDS6,EDS6/A,EDT1,EDT1/A,EDT2,EDT3,EDT6,EDT6/A,ED2,ED2/A,EN2,EN2/A,ES3,ES3/A,VMT2, VSB1,VSB1/A,VS3,VS4,VTE2
40	94103-05000	WASHER, PLAIN, 5MM	1	-	-	-----	EDN,EDN2,EDN2/A,EDS,EDS1,EDS1/A,EDS2,EDS2/A,EDS3,EDS6,EDS6/A,EDT1,EDT1/A,EDT2,EDT3,EDT6,EDT6/A,ED2,ED2/A,EN2,EN2/A,ES3,ES3/A,VMT2, VSB1,VSB1/A,VS3,VS4,VTE2
41	94540-02010	E-RING, 2MM	1	-	-	-----	EDN,EDN2,EDN2/A,EDS,EDS1,EDS1/A,EDS2,EDS2/A,EDS3,EDS6,EDS6/A,EDT1,EDT1/A,EDT2,EDT3,EDT6,EDT6/A,ED2,ED2/A,EN2,EN2/A,ES3,ES3/A,VMT2, VSB1,VSB1/A,VS3,VS4,VTE2
42	94540-04010	E-RING, 4MM	1	-	-	-----	EDN,EDN2,EDN2/A,EDS,EDS1,EDS1/A,EDS2,EDS2/A,EDS3,EDS6,EDS6/A,EDT1,EDT1/A,EDT2,EDT3,EDT6,EDT6/A,ED2,ED2/A,EN2,EN2/A,ES3,ES3/A,VMT2, VSB1,VSB1/A,VS3,VS4,VTE2
43	94540-07010	E-RING, 7MM	1	-	-	-----	EDN,EDN2,EDN2/A,EDS,EDS1,EDS1/A,EDS2,EDS2/A,EDS3,EDS6,EDS6/A,EDT1,EDT1/A,EDT2,EDT3,EDT6,EDT6/A,ED2,ED2/A,EN2,EN2/A,ES3,ES3/A,VMT2, VSB1,VSB1/A,VS3,VS4,VTE2
44	95002-02070	CLIP, TUBE (B7)	4	-	-	-----	EDN,EDN2,EDN2/A,EDS,EDS1,EDS1/A,EDS2,EDS2/A,EDS3,EDS6,EDS6/A,EDT1,EDT1/A,EDT2,EDT3,EDT6,EDT6/A,ED2,ED2/A,EN2,EN2/A,ES3,ES3/A,VMT2, VSB1,VSB1/A,VS3,VS4,VTE2
45	95005-35065-10	TUBE, 3.5X65(95005-35001-10M)	1	-	-	-----	EDN,EDN2,EDN2/A,EDS,EDS1,EDS1/A,EDS2,EDS2/A,EDS6,EDS6/A,EDT1,EDT1/A,EDT2,EDT3,EDT6,EDT6/A,ED2,ED2/A,EN2,EN2/A,ES3,ES3/A,VMT2, VSB1,VSB1/A,VS3,VS4,VTE2
	95005-35495-11	TUBE, 3.5X495(95005-35001-10M)	1	-	-	-----	EDS3



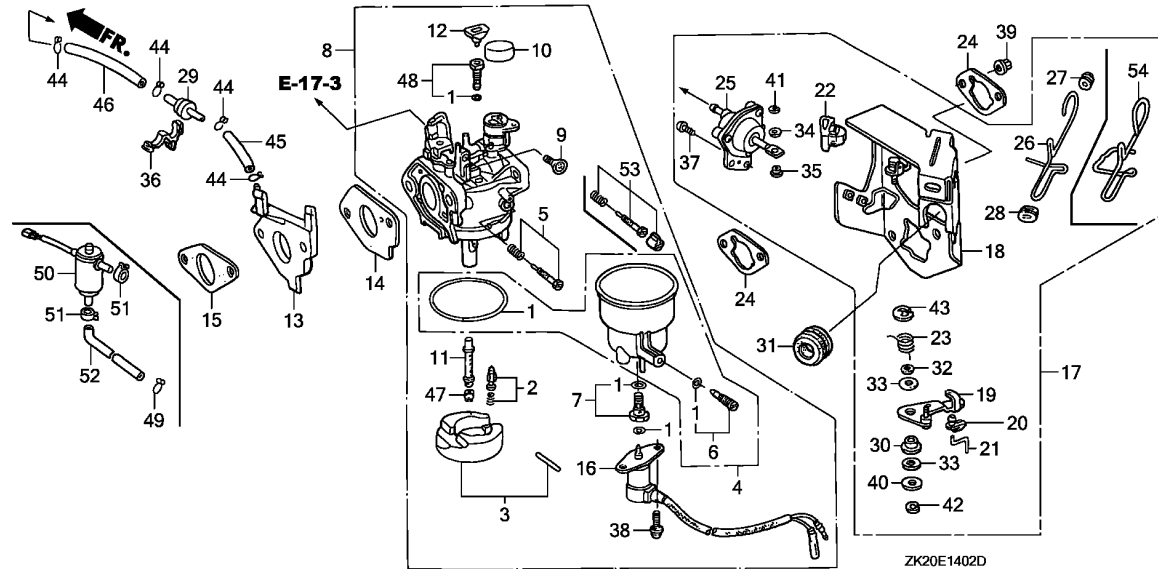

Ref. No.	Part No.	Description	Reqd. QTY			Serial No.	Parts catalogue code
			GX240K1				
			(1)	(2)	(3)		
46	95005-35130-10	TUBE, 3.5X130(95005-35001-10M)	1	-	-	EDN,EDN2,EDN2/A,EDS,EDS1,EDS1/A,EDS2,EDS2/A,EDS6,EDS6/A,EDT1,EDT1/A,EDT2,EDT3,EDT6,EDT6/A,ED2,ED2/A,EN2,EN2/A,ES3,ES3/A,VMT2	
	95005-35030-10	TUBE, 3.5X30(95005-35001-10M)	1	-	-	VSB1,VSB1/A,VS3,VS4,VTE2	EDS3
47	99101-ZF5-0750	JET, MAIN, #75 (CARBURETOR NO.)	(1)	-	-	BE20B A	EDN,EDS,EDS1,EDS3,EDT1,ED2,ES3
	99101-ZF5-0780	JET, MAIN, #78 (CARBURETOR NO.)	(1)	-	-	BE20B A	EDN,EDS,EDS1,EDS3,EDT1,ED2,ES3
	99101-ZF5-0800	JET, MAIN, #80 (CARBURETOR NO.)	(1)	-	-	BE20B A	EDN,EDS,EDS1,EDS3,EDT1,ED2,ES3
	99101-ZF5-0820	JET, MAIN, #82 (CARBURETOR NO.)	1	-	-	BE20B A	EDN,EDS,EDS1,EDS3,EDT1,ED2,ES3
	99101-ZH8-0780	JET, MAIN, #78 (CARBURETOR NO.)	(1)	-	-	EDS6,EDT6,EN2	
	99101-ZH8-0800	JET, MAIN, #80 (CARBURETOR NO.)	(1)	-	-	BE20B B	VSB1
	99101-ZH8-0820	JET, MAIN, #82 (CARBURETOR NO.)	(1)	-	-	BE20B B	EDN,EDS,EDS1,EDS3,EDT1,ES3
	99101-ZH7-0750	JET, MAIN, #75 (CARBURETOR NO.)	(1)	-	-	BE72C A	BE72C A ED2
	99101-ZH7-0780	JET, MAIN, #78 (CARBURETOR NO.)	(1)	-	-	BE72C A	BE72C A ED2
	99101-ZH7-0800	JET, MAIN, #80 (CARBURETOR NO.)	1	-	-	BE72C A	BE72C A ED2

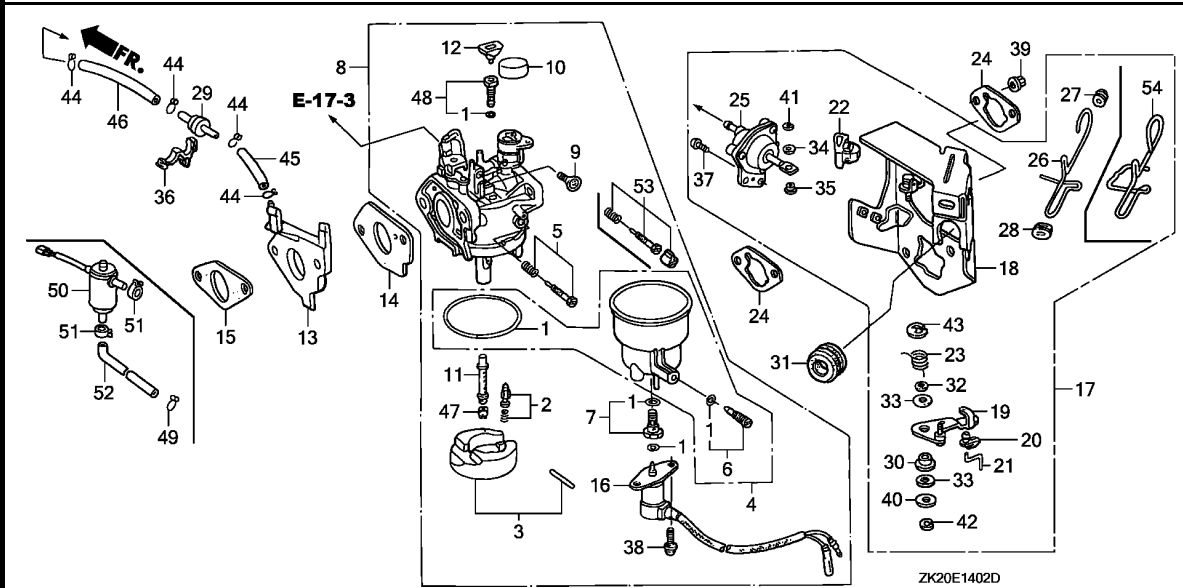

Ref. No.	Part No.	Description	Reqd. QTY			Serial No.	Parts catalogue code
			GX240K1				
			(1)	(2)	(3)		
47)	99101-ZH8-0750	JET, MAIN, #75 (CARBURETOR NO.)	(1)	-	-	EDN2,EDN2/A,EDS1/A,EDS2,EDS2/A,EDS6,EDS6/A,EDT1/A,EDT2,EDT3,EDT6 EDT6/A,ED2/A,EN2,EN2/A,ES3/A,VMT2,VSB1/A,VS3,VS4,VTE2	
	99101-ZH8-0780	JET, MAIN, #78 (CARBURETOR NO.)	(1)	-	-	EDN,EDS1,EDS3,EDT1,ED2,ES3,VSB1	
	99101-ZH8-0800	JET, MAIN, #80 (CARBURETOR NO.)	(1)	-	-	EDN2,EDN2/A,EDS1/A,EDS2,EDS2/A,EDS6,EDS6/A,EDT1/A,EDT2,EDT3,EDT6 EDT6/A,ED2/A,EN2,EN2/A,ES3/A,VMT2,VSB1/A,VS3,VS4,VTE2	
48	99204-ZE0-0450	JET SET, PILOT, #45 (CARBURETOR NO.)	1	-	-	EDN,EDS1,EDS3,EDT1,ED2,ES3,VSB1	
	99204-ZA0-0450 (CARBURETOR NO.)	1	-	-	EDN,EDS1,EDS3,EDT1,ES3,VSB1	
49	95002-02070	CLIP, TUBE (B7)	1	-	-	EDS3	
50	36170-ZB4-003	VALVE ASSY., SOLENOID	1	-	-	EDS3	
51	95002-40800-08	CLAMP, TUBE (D8)	2	-	-	EDS3	
52	95005-35695-10	TUBE, 3.5X695 (95005-35001-10M)	1	-	-	EDS3	
53	16016-ZH7-W01	SCREW SET, PILOT (CARBURETOR NO.)	1	-	-	EDN2,EDN2/A,EDS1/A,EDS2,EDS2/A,EDS6,EDS6/A,EDT1/A,EDT2,EDT3,EDT6 EDT6/A,ED2/A,EN2,EN2/A,ES3/A,VMT2,VSB1/A,VS3,VS4,VTE2	
			1	-	-	ED2	
54	16611-ZE3-D21	ROD, CHOKE CONTROL	1	-	-	EDN,EDS1,EDS3,EDT1,ES3,VSB1	
			1	-	-	VMT2	



E-14-3

CARBURETOR(4)

J 9

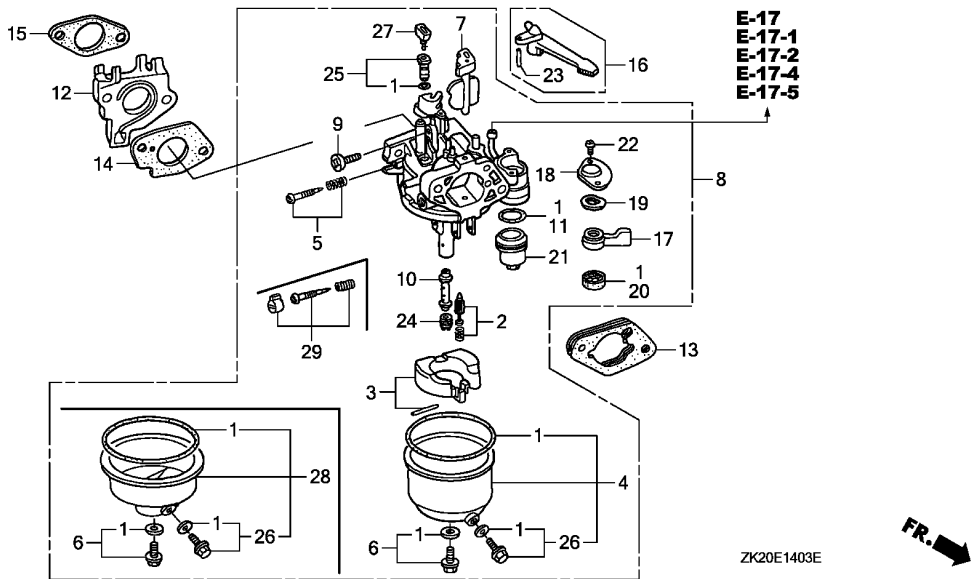

Ref. No.	L.O.N.	(Relative ref. Number) Description	F.R.T.
1	3111B1	GASKET SET, CARBURETOR (3)	0.3
2	3111E1	VALVE SET, FLOAT AND/OR FLOAT SET (28)	0.3
4	3111A3	CHAMBER SET, FLOAT AND/OR GASKET, FLOAT CHAMBER (29)	0.2
5	3111D7	SCREW SET, PILOT	0.2
8	3111F3	CARBURETOR (21)	0.2
11	3101L6	PACKING, FUEL STRAINER CUP (15)	0.2
12	3111C0	INSULATOR, CARBURETOR AND/OR PACKING, INSULATOR	0.2
13	3111D9	SPACER, CARBURETOR	0.2
14	3111C8	PACKING, CARBURETOR	0.2
16	8101F9	LEVER, CARBURETOR CHOKE (17,18,19)	0.2
20	3101C5	PACKING, FUEL COCK	0.2
24	3111C3	JET, MAIN	0.3

ZK20E1403E



Ref. No.	Part No.	Description	Reqd. QTY	Serial No.	Parts catalogue code
			GX240K1 (1) (2) (3)		

1	16010-ZE2-812	GASKET SET (INCLUDE 16173-001-004)	1	- - - - -	ED3,ED4,ED4/A,ED5,ED5/A,EN,ES,ES1,ES1/A,ES2,ET,ETS,ETX,HA,HAQ,HA2,HA2/A,HH,HHQ4,HHQ4/A,HTX,HX,HX/A,HXQ4,HXQ4/A,LH,LH/A,LHE,LHE4,LHE4/A,LHZ,LJ,LJ/A,LJG,LJG/A,LJG1,LK,LKS,LKS/A,LM9,LNJ,LNZ,LP,LP/A,LSS4,LSS5,LSS5/A,LSX,LSX/A,LT,LT/A,LW,LX,LX/A,LXF,LXQ4,LXQ4/A,LXZ,LX2,LX2/A,PA,PAE,PA2,PA2/A,PMT2,PMT2/A,PX,PX/A,QA,QAE,QAE2,QAE2/A,QAG,QAG/A,QAG2,QAG2/A,QAQ,QAQ4,QA2,QA2/A,QDA,QE,QE/A,QH,QH/A,QHB2,QHC,QHE,QHP1,QHP1/A,QHQ4,QHQ4/A,QHZ,QKA2,QMH,QMH/A,QP,QP/A,QT,QT/A,QW24,QX,QX/A,QXB,QXB7,QXB7/A,QXC,QXC/A,QXC9,QXC9/A,QXE,QXE/A,QXEB,QXE4,QXE4/A,QXQ4,QXQ4/A,QXU,QXU/A,RA,RA2,RA2/A,RH,RHE,RHE4,RHQ4,RHQ4/A,RJ,RJ/A,RSC2,RSS1,RSS1/A,RX,RX/A,RXQ4,RXQ4/A,SE,SE/A,SH,SHE,SHEZ,SHW,SHW/A,SJ,SJ/A,SJC,SJC1,SJC1/A,SJC5,SJC5/A,SJG,SJG/A,SJP,SK,SMS,SMS/A,SMX2,SMX2/A,SNE1,SNR,SNR/A,STP,STP/A,STQ,STQ/A,SW,SWE,SX,SX/A,SBX,SXE,SXEB,SXE4,SXE4/A,SXQ4,SXQ4/A,SXU,SXU/A,VA,VAH1,VA2,VA2/A,VH,VH/A,VH12,VH12/A,VMX,VNG,VTA,VTA2,VTA2/A,VX,VX/A,VXB,VXB/A,VXB7,VXB7/A,VXE,VXE/A,VXEB,VXEB/A,VXQ4,VXQ4/A,VXQ7,VXQ7/A,VXU,VXU/A,VXU1,VXU1/A,WH,WJ,WJ/A,WKD6,WKD6/A,WKT2,WKT2/A,WKT4,WKT4/A
			(1)	-	

2

Ref. No.	Part No.	Description	Reqd. QTY			Serial No.	Parts catalogue code
			(1)	(2)	(3)		
2	16011-ZA0-931	VALVE SET, FLOAT	1	-	-	ED3,ED4,ED4/A,ED5,ED5/A,EN,ES,ES1,ES1/A,ES2,ET,ETS,ETX,HA,HAQ,HA2,HA2/A,HH,HHQ4,HHQ4/A,HTX,HX,HX/A,HXQ4,HXQ4/A,LH,LH/A,LHE,LHE4,LHE4/A,LHZ,LJ,LJ/A,LJG,LJG/A,LJG1,LK,LKS,LKS/A,LM9,LNJ,LNZ,LP,LP/A,LSS4,LSS5,LSS5/A,LSX,LSX/A,LT,LT/A,LW,LX,LX/A,LXF,LXQ4,LXQ4/A,LXZ,LX2,LX2/A,PA,PAE,PA2,PA2/A,PMT2,PMT2/A,PX,PX/A,QA,QAE,QAE2,QAE2/A,QAG,QAG/A,QAG2,QAG2/A,QAQ,QAQ4,QA2,QA2/A,QDA,QE,QE/A,QH,QH/A,QHB2,QHC,QHE,QHP1,QHP1/A,QHQ4,QHQ4/A,QHZ,QKA2,QMH,QMH/A,QP,QP/A,QT,QT/A,QW24,QX,QX/A,QXB,QXB7,QXB7/A,QXC,QXC/A,QXC9,QXC9/A,QXE,QXE/A,QXEB,QXE4,QXE4/A,QXQ4,QXQ4/A,QXU,QXU/A,RA,RA2,RA2/A,RH,RHE,RHE4,RHQ4,RHQ4/A,RJ,RJ/A,RSC2,RSS1,RSS1/A,RX,RX/A,RXQ4,RXQ4/A,SE,SE/A,SH,SHE,SHEZ,SHW,SHW/A,SJ,SJ/A,SJC,SJC1,SJC1/A,SJC5,SJC5/A,SJG,SJG/A,SJP,SK,SMS,SMS/A,SMX2,SMX2/A,SNE1,SNR,SNR/A,STP,STP/A,STQ,STQ/A,SW,SWE,SX,SX/A,SBX,SXE,SXEB,SXE4,SXE4/A,SXQ4,SXQ4/A,SXU,SXU/A,VA,VAH1,VA2,VA2/A,VH,VH/A,VH12,VH12/A,VMX,VNG,VTA,VTA2,VTA2/A,VX,VX/A,VXB,VXB/A,VXB7,VXB7/A,VXE,VXE/A,VXEB,VXEB/A,VXQ4,VXQ4/A,VXQ7,VXQ7/A,VXU,VXU/A,VXU1,VXU1/A,WH,WJ,WJ/A,WKD6,WKD6/A,WKT2,WKT2/A,WKT4,WKT4/A	
3	16013-ZA0-931	FLOAT SET	1	(1)	-	ED3,ED4,ED4/A,ED5,ED5/A,EN,ES,ES1,ES1/A,ES2,ET,ETS,ETX,HA,HAQ,HA2,HA2/A,HH,HHQ4,HHQ4/A,HTX,HX,HX/A,HXQ4,HXQ4/A,LH,LH/A,LHE,LHE4,LHE4/A,LHZ,LJ,LJ/A,LJG,LJG/A,LJG1,LK,LKS,LKS/A,LM9,LNJ,LNZ,LP,LP/A,LSS4,LSS5,LSS5/A,LSX,LSX/A,LT,LT/A,LW,LX,LX/A,LXF,LXQ4,LXQ4/A,LXZ,LX2,LX2/A,PA,PAE,PA2,PA2/A,PMT2,PMT2/A,PX,PX/A,QA,QAE,QAE2,QAE2/A,QAG,QAG/A,QAG2,QAG2/A,QAQ,QAQ4,QA2,QA2/A,QDA,QE,QE/A,QH,QH/A,QHB2,QHC,QHE,QHP1,QHP1/A,QHQ4,QHQ4/A,QHZ,QKA2,QMH,QMH/A,QP,QP/A,QT,QT/A,QW24,QX,QX/A,QXB,QXB7,QXB7/A,QXC,QXC/A,QXC9,QXC9/A,QXE,QXE/A,QXEB,QXE4,QXE4/A,QXQ4,QXQ4/A,QXU,QXU/A,RA,RA2,RA2/A,RH,RHE,RHE4,RHQ4,RHQ4/A,RJ,RJ/A,RSC2,RSS1,RSS1/A,RX,RX/A,RXQ4,RXQ4/A,SE,SE/A,SH,SHE,SHEZ,SHW,SHW/A,SJ,SJ/A,SJC,SJC1,SJC1/A,SJC5,SJC5/A,SJG,SJG/A,SJP,SK,SMS,SMS/A,SMX2,SMX2/A,SNE1,SNR,SNR/A,STP,STP/A,STQ,STQ/A,SW,SWE,SX,SX/A,SBX,SXE,SXEB,SXE4,SXE4/A,SXQ4,SXQ4/A,SXU,SXU/A,VA,VAH1,VA2,VA2/A,VH,VH/A,VH12,VH12/A,VMX,VNG,VTA,VTA2,VTA2/A,VX,VX/A,VXB,VXB/A,VXB7,VXB7/A,VXE,VXE/A,VXEB,VXEB/A,VXQ4,VXQ4/A,VXQ7,VXQ7/A,VXU,VXU/A,VXU1,VXU1/A,WH,WJ,WJ/A,WKD6,WKD6/A,WKT2,WKT2/A,WKT4,WKT4/A	
4	16015-ZE2-005	CHAMBER SET, FLOAT	1	(1)	-	ED3,ED4,ED5,EN,ES,ES1,ET,ETS,ETX,HA,HH,HHQ4,HTX,HX,HXQ4,LH,LHE,LHE4,LJ,LJG,LK,LKS,LM9,LNJ,LNZ,LP,LW,LX,LXQ4,LXZ,L1,PA,PAE,PX,P1,QA,QAE,QAQ4,QE,QH,QHE,QHQ4,QP,QT,QX,QXB,QXE,QXE4,QXC9,Q1,RA,RH,RHE,RHE4,RHQ4,RJ,RX,RXQ4,R1,SE,SH,SHE,SHEZ,SJ,SJC,SJG,SJP,SK,SMS,SNE1,SNR,STP,STQ,SW,SWE,SX,SBX,SXE,SXEB,SXE4,SXQ4,S1,VA,VAH1,VH,VNG,VTA,VX,VXB,VXE,VXEB,VXQ4,VXU,V1,WH,WJ,W1	
		(CARBURETOR NO.)	1	-	-	QDA	
			1	-	-	BE16D A QHC,QXC	
			1	-	-	BE70A A HAQ,QAQ,QXC9	
			1	-	-	BE70B A HA2,LX2,PA2,PMT2,QAE2,QAG2,QA2,RA2,RSC2,SMX2,VA2,VH12,WKT2	



E-14-3

CARBURETOR(4)

J11

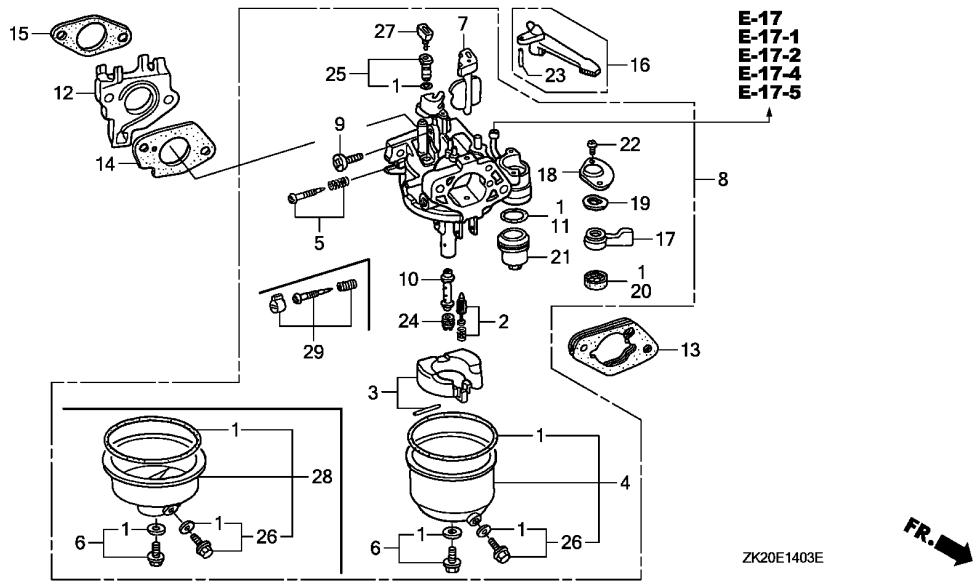

Ref. No.	Part No.	Description	Reqd. QTY			Serial No.	Parts catalogue code
			GX240K1				
			(1)	(2)	(3)		
5	16016-ZE0-005	SCREW SET, PILOT	1	(1)	-	-----	EN,ES,ES1,ET,ETS,ETX,HA,HH,HTX,LJ,LJG,LJG1,LK,LKS,LM9,LNJ,LNZ,LP,LSS4,LSS5,LT,LW,LXZ,L1,PA,PAE,P1,QA,QAE,QDA,QE,QHC,QHE,QP,QT,QXB,QXEB,Q1,RA,RH,RHE,RHE4,RJ,RSS1,R1,SE,SH,SHEZ,SJ,SJC,SJC1,SJC5,SJSJP,SK,SMS,SNE1,SW,SWE,SXB,SXE,SXEB,S1,VA,VAH1,VNG,VTA,V1,WH,WJ,W1
		(CARBURETOR NO.)	1	(1)	-	-----	BE15G B ES1/A,LJ/A,LJG/A,LKS/A,LP/A,LSS5/A,LSX,LT/A,L1/A,QE/A,QP/A,QT/A,Q1/A,RJ/A,RSS1/A,R1/A,SE/A,SHW,SHW/A,SJ/A,SJC1/A,SJC5/A,SJG/A,SMS/A,SNR,STP,STQ,S1/A,WJ/A,W1/A
		//	1	-	-	-----	BE16D B QXC
		//	1	-	-	-----	BE70B A ED3,ED4,ED5,HHQ4,HX,HXQ4,LH,LHE,LHE4,LHZ,LX,LXQ4,PX,QAQ4,QH,QHP1,QHQ4,QHZ,QMH,QX,QXE,QXE4,QXQ4,QXU,RHQ4,RX,RXQ4,SHE,SX,SXE4,SXQ4,SXU,VH,VMX,VX,VXB,VXE,VXEB,VXQ4,VXU,VXU1

2

E-14-3

CARBURETOR(4)

J12

Ref. No.	Part No.	Description	Reqd. QTY			Serial No.	Parts catalogue code
			(1)	(2)	(3)		
6	16028-ZE0-005	SCREW SET	1	-	-		ED3,ED4,ED4/A,ED5,ED5/A,EN,ES,ES1,ES1/A,ES2,ET,ETS,ETX,HA,HAQ,HA2,HA2/A,HH,HHQ4,HHQ4/A,HTX,HX,HX/A,HXQ4,HXQ4/A,LH,LH/A,LHE,LHE4,LHE4/A,LHZ,LJ,LJ/A,LJG,LJG/A,LJG1,LK,LKS,LKS/A,LM9,LNJ,LNZ,LP,LP/A,LSS4,LSS5,LSS5/A,LSX,LSX/A,LT,LT/A,LW,LX,LX/A,LXF,LXQ4,LXQ4/A,LXZ,LX2,LX2/A,PA,PAE,PA2,PA2/A,PMT2,PMT2/A,PX,PX/A,QA,QAE,QAE2,QAE2/A,QAG,QAG/A,QAG2,QAG2/A,QAQ,QAQ4,QA2,QA2/A,QDA,QE,QE/A,QH,QH/A,QHB2,QHC,QHE,QHP1,QHP1/A,QHQ4,QHQ4/A,QHZ,QKA2,QMH,QMH/A,QP,QP/A,QT,QT/A,QW24,QX,QX/A,QXB,QXB7,QXB7/A,QXC,QXC/A,QXC9,QXC9/A,QXE,QXE/A,QXEB,QXE4,QXE4/A,QXQ4,QXQ4/A,QXU,QXU/A,RA,RA2,RA2/A,RH,RHE,RHE4,RHQ4,RHQ4/A,RJ,RJ/A,RSC2,RSS1,RSS1/A,RX,RX/A,RXQ4,RXQ4/A,SE,SE/A,SH,SHE,SHEZ,SHW,SHW/A,SJ,SJ/A,SJC,SJC1,SJC1/A,SJC5,SJC5/A,SJG,SJG/A,SJP,SK,SMS,SMS/A,SMX2,SMX2/A,SNE1,SNR,SNR/A,STP,STP/A,STQ,STQ/A,SW,SWE,SX,SX/A,SBX,SXE,SXEB,SXE4,SXE4/A,SXQ4,SXQ4/A,SXU,SXU/A,VA,VAH1,VA2,VA2/A,VH,VH/A,VH12,VH12/A,VMX,VNG,VTA,VTA2,VTA2/A,VX,VX/A,VXB,VXB/A,VXB7,VXB7/A,VXE,VXE/A,VXEB,VXEB/A,VXQ4,VXQ4/A,VXQ7,VXQ7/A,VXU,VXU/A,VXU1,VXU1/A,WH,WJ,WJ/A,WKD6,WKD6/A,WKT2,WKT2/A,WKT4,WKT4/A
7	16044-ZE2-005	CHOKE SET	1	(1)	-		ED3,ED4,ED4/A,ED5,ED5/A,EN,ES,ES1,ES1/A,ES2,ET,ETS,ETX,HA,HAQ,HA2,HA2/A,HH,HHQ4,HHQ4/A,HTX,HX,HX/A,HXQ4,HXQ4/A,LH,LH/A,LHE,LHE4,LHE4/A,LHZ,LJ,LJ/A,LJG,LJG/A,LJG1,LK,LKS,LKS/A,LM9,LNJ,LNZ,LP,LP/A,LSS4,LSS5,LSS5/A,LSX,LSX/A,LT,LT/A,LW,LX,LX/A,LXF,LXQ4,LXQ4/A,LXZ,LX2,LX2/A,PA,PAE,PA2,PA2/A,PMT2,PMT2/A,PX,PX/A,QA,QAE,QAE2,QAE2/A,QAG,QAG/A,QAG2,QAG2/A,QAQ,QAQ4,QA2,QA2/A,QDA,QE,QE/A,QH,QH/A,QHB2,QHC,QHE,QHP1,QHP1/A,QHQ4,QHQ4/A,QHZ,QKA2,QMH,QMH/A,QP,QP/A,QT,QT/A,QW24,QX,QX/A,QXB,QXB7,QXB7/A,QXC,QXC/A,QXC9,QXC9/A,QXE,QXE/A,QXEB,QXE4,QXE4/A,QXQ4,QXQ4/A,QXU,QXU/A,RA,RA2,RA2/A,RH,RHE,RHE4,RHQ4,RHQ4/A,RJ,RJ/A,RSC2,RSS1,RSS1/A,RX,RX/A,RXQ4,RXQ4/A,SE,SE/A,SH,SHE,SHEZ,SHW,SHW/A,SJ,SJ/A,SJC,SJC1,SJC1/A,SJC5,SJC5/A,SJG,SJG/A,SJP,SK,SMS,SMS/A,SMX2,SMX2/A,SNE1,SNR,SNR/A,STP,STP/A,STQ,STQ/A,SW,SWE,SX,SX/A,SBX,SXE,SXEB,SXE4,SXE4/A,SXQ4,SXQ4/A,SXU,SXU/A,VA,VAH1,VA2,VA2/A,VH,VH/A,VH12,VH12/A,VMX,VNG,VTA,VTA2,VTA2/A,VX,VX/A,VXB,VXB/A,VXB7,VXB7/A,VXE,VXE/A,VXEB,VXEB/A,VXQ4,VXQ4/A,VXQ7,VXQ7/A,VXU,VXU/A,VXU1,VXU1/A,WH,WJ,WJ/A,WKD6,WKD6/A,WKT2,WKT2/A,WKT4,WKT4/A
8	16100-ZE2-W10	CARBURETOR ASSY. (BE16D A) ..	1	(1)	-	3453913	L1,P1,QHC,QXC,Q1,R1,V1,W1
	16100-ZE2-W30	CARBURETOR ASSY. (BE15G A) ..	1	(1)	-	3453255	S1,S1/A ED3,ED4,ED5,EN,ES,ES1,ET,ETS,ETX,HA,HH,HHQ4,HTX,HX,HXQ4,LH,LHE,LHE4,LJ,LJG,LK,LKS,LM9,LNJ,LNZ,LP,LW,LX,LXQ4,LXZ,L1,PA,PAE,PX,P1,QA,QAE,QAQ4,QE,QH,QHE,QHQ4,QP,QT,QX,QXB,QXE,QXEB,QXE4,QXQ4,Q1,RA,RH,RHE,RHE4,RHQ4,RJ,RX,RXQ4,R1,SE,SH,SHE,SHEZ,SJ,SJC,SJG,SJP,SK,SMS,SNE1,SNR,STP,STQ,SW,SWE,SX,SBX,SXE,SXEB,SXE4,SXQ4,S1,VA,VAH1,VH,VNG,VTA,VX,VXB,VXE,VXEB,VXQ4,VXU,V1,WH,WJ,W1
	16100-ZE2-W50	CARBURETOR ASSY. (BE70A A) ..	1	-	-	3456902	QDA HAQ,QAQ,QXC9
	16100-ZE2-W70	CARBURETOR ASSY. (BE70B A) ..	1	-	-	3453330	HA2,LX2,PA2,PMT2,QAE2,QAG2,QA2,RA2,RSC2,SMX2,VA2,VH12,WKT2
	16100-ZE2-W11	CARBURETOR ASSY. (BE16D B) ..	1	(1)	-		LSS4,L1/A,Q1/A,R1/A,W1/A
			1	(1)	-	3453914	L1,P1,QHC,Q1,R1,V1,W1
			1	-	-	3453914	3860624 QXC

2

E-14-3

CARBURETOR(4)

J13

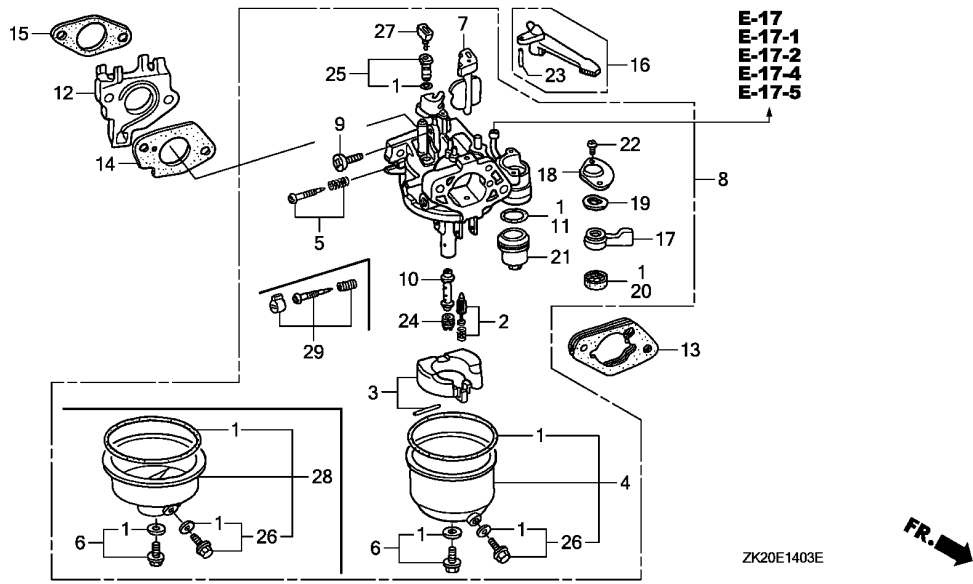

Ref. No.	Part No.	Description	Reqd. QTY			Serial No.	Parts catalogue code
			GX240K1				
			(1)	(2)	(3)		
(8)	16100-ZE2-W31	CARBURETOR ASSY. (BE15G B) ..	1	(1)	-	3453256	----- EN,ES,ES1,ET,ETS,ETX,HA,HH,HTX,LJ,LJG,LK,LKS,LM9,LNJ,LNZ,LP,LW,LXZ,L1,PA,PAE,P1,QA,QAE,QE,QHE,QP,QT,QXB,QXEB,Q1,RA,RH,RHE,RHE4,RJ,R1,SE,SH,SHEZ,SJ,SJC,SJG,SJP,SK,SMS,SNE1,SW,SWE,AXB,SXE,SXEB,S1,VA,VAH1,VNG,VTA,V1,WH,WJ,W1
			1	(1)	-	4659958	----- ES1/A,LJ/A,LJG/A,LKS/A,LP/A,LSS5/A,LT/A,L1/A,QE/A,QP/A,QT/A,Q1/A,RJ/A,RSS1/A,R1/A,SE/A,SHW/A,SJ/A,SJC1/A,SJC5/A,SJG/A,SMS/A,S1/A,WJ/A,W1/A
			1	-	-	-----	----- LJG1,LSS5,LT,RSS1,SHW,SJC1,SJC5
			1	-	-	3860624	----- LHZ,LSX,QHP1,QHZ,QMH,QXU,SXU,VMX,VXU1
			1	-	-	3453256	3860624 ED3,ED4,ED5,HHQ4,HX,HXQ4,LH,LHE,LHE4,LX,LXQ4,PX,QAQ4,QH,QHQ4,QX,QXE,QXE4,QXQ4,RHQ4,RX,RXQ4,SHE,SNR,STP,STQ,SX,SXE4,SXQ4,VH,VX,VXB,VXE,VXEB,VXQ4,VXU
	16100-ZE2-W32	CARBURETOR ASSY. (BE15G C) ..	1	(1)	-	4659959	----- ES1/A,LJ/A,LJG/A,LKS/A,LP/A,LSS5/A,LT/A,L1/A,QE/A,QP/A,QT/A,Q1/A,RJ/A,RSS1/A,R1/A,SE/A,SHW/A,SJ/A,SJC1/A,SJC5/A,SJG/A,SMS/A,S1/A,WJ/A,W1/A
			1	-	-	-----	----- ES2
	16100-ZE2-W51	CARBURETOR ASSY. (BE70A B) ..	1	-	-	-----	----- QXC/A,QXC9/A
			1	-	-	3456903	----- HAQ,QAQ,QXC9
			1	-	-	3860625	----- QXC

2

Ref. No.	Part No.	Description	Reqd. QTY			Serial No.	Parts catalogue code
			(1)	(2)	(3)		
(8)	16100-ZE2-W71	CARBURETOR ASSY. (BE70B B/C)	1	-	-	-----	ED4/A,ED5/A,HA2/A,HHQ4/A,HX/A,HXQ4/A,LH/A,LHE4/A,LSX/A,LX/A,LXF LXQ4/A,LX2/A,PA2/A,PMT2/A,PX/A,QAE2/A,QAG,QAG/A,QAG2/A,QA2/A,QH/A QHB2,QHP1/A,QHQ4/A,QKA2,QMH/A,QW24,QX/A,QXB7,QXB7/A,QXE/A,QXE4/A QXQ4/A,QXU/A,RA2/A,RHQ4/A,RX/A,RXQ4/A,SMX2/A,SNR/A,STP/A,STQ/A SX/A,SXE4/A,SXQ4/A,SXU/A,VA2/A,VH/A,VH12/A,VT2,VT2/A,VX/A,VXB/A VXB7/VXB7/A,VXE/A,VXEB/A,VXQ4/A,VXQ7,VXQ7/A,VXU/A,VXU1/A,WKD6 WKD6/A,WKT2/A,WKT4,WKT4/A
			1	-	-	3453331	----- HA2, LX2, PA2, PMT2, QAE2, QAG2, QA2, RA2, RSC2, SMX2, VA2, VH12, WKT2
			1	-	-	3860625	----- ED3, ED4, ED5, HHQ4, HX, HXQ4, LH, LHE, LHE4, LHZ, LSX, LX, LXQ4, PX, QAQ4, QH QHP1, QHQ4, QHZ, QMH, QX, QXE, QXE4, QXQ4, QXU, RHQ4, RX, RXQ4, SHE, SNR, STP STQ, SX, SXE4, SXQ4, SXU, VH, VMX, VX, VXB, VXE, VXEB, VXQ4, VXU, VXU1
9	16124-ZE0-005	SCREW, THROTTLE STOP	1	-	-	-----	ED3,ED4,ED4/A,ED5,ED5/A,EN,ES,ES1,ES1/A,ES2,ET,ETS,ETX,HA,HAQ,HA2 HA2/A,HH,HHQ4,HHQ4/A,HTX,HX,HX/A,HXQ4,HXQ4/A,HL,HL/A,LHE,LHE4 LHE4/A,LHZ,LJ,LJ/A,LJG,LJG/A,LJG1,LK,LKS,LKS/A,LM9,LNJ,LNZ,LP LP/A,LSS4,LSS5,LSS5/A,LSX,LSX/A,LT,LT/A,LW,LX,LX/A,LXF,LXQ4 LXQ4/A,LX2,LX2/A,PA,PAE,PA2,PA2/A,PMT2,PMT2/A,PX,PX/A,QA,QAE QAE2,QAE2/A,QAG,QAG/A,QAG2,QAG2/A,QAQ,QAQ4,QA2,QA2/A,QDA,QE,QE/A QH,QH/A,QHB2,QHC,QHE,QHP1,QHP1/A,QHQ4,QHQ4/A,QHC,QKA2,QMH,QMH/A QP,QP/A,QT,QT/A,QW24,QX,QX/A,QXB,QXB7,QXB7/A,QXC,QXC/A,QXC9 QXC9/A,QXE,QXE/A,QXEB,QXE4,QXE4/A,QXQ4,QXQ4/A,QXU,QXU/A,RA,RA2 RA2/A,RH,RHE,RHE4,RHQ4,RHQ4/A,RJ,RJ/A,RSC2,RSS1,RSS1/A,RX,RX/A RXQ4,RXQ4/A,SE,SE/A,SH,SHE,SHEZ,SHW,SHW/A,SJ,SJ/A,SJC,SJC1,SJC1/A SJC5,SJC5/A,SJG,SJG/A,SJP,SK,SMS,SMS/A,SMX2,SMX2/A,SNE1,SNR,SNR/A STP,STP/A,STQ,STQ/A,SW,SWE,SX,SX/A,SXB,SXE,SXEB,SXE4,SXE4/A,SXQ4 SXQ4/A,SXU,SXU/A,VA,VAH1,VA2,VA2/A,VH,VH/A,VH12,VH12/A,VMX,VNG VTA,VTA2,VTA2/A,VX,VX/A,VXB,VXB/A,VXB7,VXB7/A,VXE,VXE/A,VXEB VXEB/A,VXQ4,VXQ4/A,VXQ7,VXQ7/A,VXU,VXU/A,VXU1,VXU1/A,WH,WJ,WJ/A WKD6,WKD6/A,WKT2,WKT2/A,WKT4,WKT4/A
10	16166-ZE2-W70	NOZZLE, MAIN	-	(1)	-	-----	ED4/A,ED5/A,HA2,HA2/A,HHQ4/A,HX/A,HXQ4/A,LH/A,LHE4/A,LSX/A,LX/A LXF,LXQ4/A,LX2,LX2/A,PA2,PA2/A,PMT2,PMT2/A,PX/A,QAE2,QAE2/A,QAG QAG/A,QAG2,QAG2/A,QA2,QA2/A,QH/A,QHB2,QHP1/A,QHQ4/A,QKA2,QMH/A QW24,QX/A,QXB7,QXB7/A,QXE/A,QXE4/A,QXQ4/A,QXU/A,RA2,RA2/A,RHQ4/A RSC2,RX/A,RXQ4/A,SMX2,SMX2/A,SNR/A,STP/A,STQ/A,SX/A,SXE4/A,SXQ4/A SXU/A,VA2,VA2/A,VH/A,VH12,VH12/A,VT2,VT2/A,VX/A,VXB/A,VXB7 VXB7/A,VXE/A,VXEB/A,VXQ4/A,VXQ7,VXQ7/A,VXU/A,VXU1/A,WKD6,WKD6/A WKT2,WKT2/A,WKT4,WKT4/A
		(CARBURETOR NO.)	1	-	-	BE70B B	----- ED3,ED4,ED5,HHQ4,HX,HXQ4,LH,LHE,LHE4,LHZ,LSX,LX,LXQ4,PX,QAQ4,QH QHP1,QHQ4,QHZ,QMH,QX,QXE,QXE4,QXQ4,QXU,RHQ4,RX,RXQ4,SHE,SNR,STP STQ,SX,SXE4,SXQ4,SXU,VH,VMX,VX,VXB,VXE,VXEB,VXQ4,VXU,VXU1
	16166-ZE2-015	1	-	-	-----	EN,ES,ES1,ES1/A,ES2,ET,ETS,ETX,HA,HH,HTX,LJ,LJ/A,LJG,LJG/A,LJG1 LK,LKS,LKS/A,LM9,LNJ,LNZ,LP,LP/A,LSS4,LSS5,LSS5/A,LT,LT/A,LW,LX2 PA,PAE,QA,QAE,QDA,QE,QE/A,QHC,QHE,QP,QP/A,QT,QT/A,QXB,QXEB,RA,RH RHE,RHE4,RJ,RJ/A,RSS1,RSS1/A,SE,SE/A,SH,SHEZ,SHW,SHW/A,SJ,SJ/A SJC,SJC1,SJC1/A,SJC5,SJC5/A,SJG,SJG/A,SJP,SK,SMS,SMS/A,SNE1,SW SWE,SXB,SXE,SXEB,VA,VAH1,VNG,VTA,WH,WJ,WJ/A
		(CARBURETOR NO.)	1	-	-	BE15G B	----- LSX,SNR,STP,STQ
		//	1	-	-	BE16D B	----- QXC
		//	1	-	-	BE70B A	----- ED3,ED4,ED5,HHQ4,HX,HXQ4,LH,LHE,LHE4,LHZ,LX,LXQ4,PX,QAQ4,QH,QHP1 QHQ4,QHZ,QMH,QX,QXE,QXE4,QXQ4,QXU,RHQ4,RX,RXQ4,SHE,SX,SXE4,SXQ4 SXU,VH,VMX,VX,VXB,VXE,VXEB,VXQ4,VXU,VXU1
	16166-ZH9-W00	-	(1)	-	-----	HAQ,QAQ,QXC/A,QXC9,QXC9/A
		(CARBURETOR NO.)	1	-	-	BE70A B	----- QXC



E-14-3

CARBURETOR(4)

J15

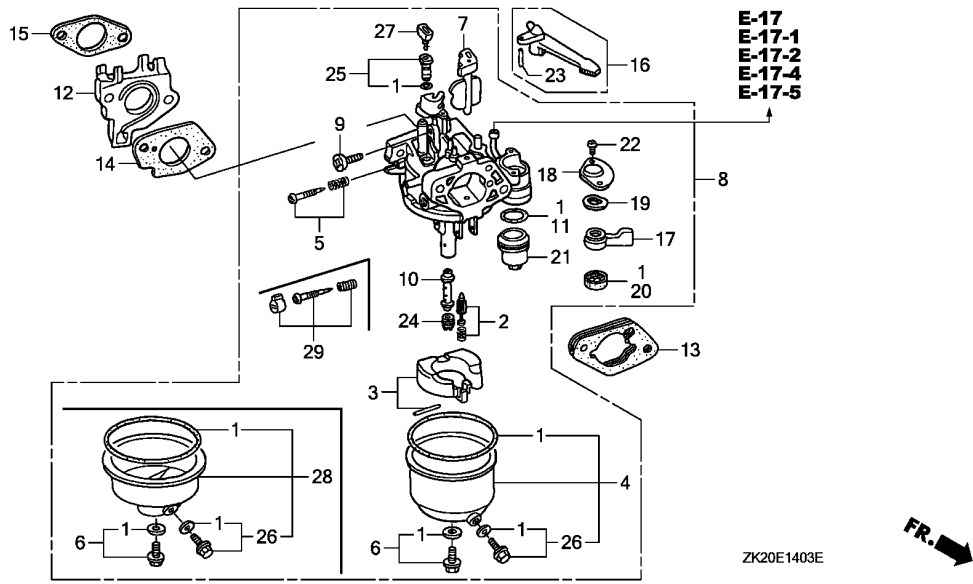

Ref. No.	Part No.	Description	Reqd. QTY			Serial No.	Parts catalogue code
			(1)	(2)	(3)		
11	16173-001-004	PACKING, FUEL STRAINER CUP ..	1	-	-	-----	ED3,ED4,ED4/A,ED5,ED5/A,EN,ES,ES1,ES1/A,ES2,ET,ETS,ETX,HA,HAQ,HA2,HA2/A,HH,HHQ4,HHQ4/A,HTX,HX,HX/A,HXQ4,HXQ4/A,LH,LH/A,LHE,LHE4,LHE4/A,LHZ,LJ,LJ/A,LJG,LJG/A,LJG1,LK,LKS,LKS/A,LM9,LNJ,LNZ,LP,LP/A,LSS4,LSS5,LSS5/A,LSX,LSX/A,LT,LT/A,LW,LX,LX/A,LXF,LXQ4,LXQ4/A,LXZ,LX2,LX2/A,PA,PAE,PA2,PA2/A,PMT2,PMT2/A,PX,PX/A,QA,QAE,QAE2,QAE2/A,QAG,QAG/A,QAG2,QAG2/A,QAQ,QAQ4,QA2,QA2/A,QDA,QE,QE/A,QH,QH/A,QHB2,QHC,QHE,QHP1,QHP1/A,QHQ4,QHQ4/A,QHZ,QKA2,QMH,QMH/A,QP,QP/A,QT,QT/A,QW24,QX,QX/A,QXB,QXB7,QXB7/A,QXC,QXC/A,QXC9,QXC9/A,QXE,QXE/A,QXEB,QXE4,QXE4/A,QXQ4,QXQ4/A,QXU,QXU/A,RA,RA2,RA2/A,RH,RHE,RHE4,RHQ4,RHQ4/A,RJ,RJ/A,RSC2,RSS1,RSS1/A,RX,RX/A,RXQ4,RXQ4/A,SE,SE/A,SH,SHE,SHEZ,SHW,SHW/A,SJ,SJ/A,SJC,SJC1,SJC1/A,SJC5,SJC5/A,SJG,SJG/A,SJP,SK,SMS,SMS/A,SMX2,SMX2/A,SNE1,SNR,SNR/A,STP,STP/A,STQ,STQ/A,SW,SWE,SX,SX/A,SXB,SXE,SXEB,SXE4,SXE4/A,SXQ4,SXQ4/A,SXU,SXU/A,VA,VAH1,VA2,VA2/A,VH,VH/A,VH12,VH12/A,VMX,VNG,VTA,VTA2,VTA2/A,VX,VX/A,VXB,VXB/A,VXB7,VXB7/A,VXE,VXE/A,VXEB,VXEB/A,VXQ4,VXQ4/A,VXQ7,VXQ7/A,VXU,VXU/A,VXU1,VXU1/A,WH,WJ,WJ/A,WKD6,WKD6/A,WKT2,WKT2/A,WKT4,WKT4/A
			- (1) -				

2

E-14-3

CARBURETOR(4)

J16

Ref. No.	Part No.	Description	Reqd. QTY			Serial No.	Parts catalogue code
			(1)	(2)	(3)		
12	16211-ZE2-000	INSULATOR, CARBURETOR	1	-	-	ED3,ED4,ED4/A,ED5,ED5/A,EN,ES,ES1,ES1/A,ES2,ET,ETS,ETX,HA,HAQ,HA2,HA2/A,HH,HHQ4,HHQ4/A,HTX,HX,HX/A,HXQ4,HXQ4/A,LH,LH/A,LHE,LHE4,LHE4/A,LHZ,LJ,LJ/A,LJG,LJG/A,LJG1,LK,LKS,LKS/A,LM9,LNJ,LNZ,LP,LP/A,LSS4,LSS5,LSS5/A,LSX,LSX/A,LT,LT/A,LW,LX,LX/A,LXF,LXQ4,LXQ4/A,LXZ,LX2,LX2/A,PA,PAE,PA2,PA2/A,PMT2,PMT2/A,PX,PX/A,QA,QAE,QAE2,QAE2/A,QAG,QAG/A,QAG2,QAG2/A,QAQ,QAQ4,QA2,QA2/A,QDA,QE,QE/A,QH,QH/A,QHB2,QHC,QHE,QHP1,QHP1/A,QHQ4,QHQ4/A,QHZ,QKA2,QMH,QMH/A,QP,QP/A,QT,QT/A,QW24,QX,QX/A,QXB,QXB7,QXB7/A,QXC,QXC/A,QXC9,QXC9/A,QXE,QXE/A,QXEB,QXE4,QXE4/A,QXQ4,QXQ4/A,QXU,QXU/A,RA,RA2,RA2/A,RH,RHE,RHE4,RHQ4,RHQ4/A,RJ,RJ/A,RSC2,RSS1,RSS1/A,RX,RX/A,RXQ4,RXQ4/A,SE,SE/A,SH,SHE,SHEZ,SHW,SHW/A,SJ,SJ/A,SJC,SJC1,SJC1/A,SJC5,SJC5/A,SJG,SJG/A,SJP,SK,SMS,SMS/A,SMX2,SMX2/A,SNE1,SNR,SNR/A,STP,STP/A,STQ,STQ/A,SW,SWE,SX,SX/A,SBX,SXE,SXEB,SXE4/SXQ4/SXQ4/A,SXU,SXU/A,VA,VAH1,VA2,VA2/A,VH,VH/A,VH12,VH12/A,VMX,VNG,VTA,VTA2,VTA2/A,VX,VX/A,VXB,VXB/A,VXB7,VXB7/A,VXE,VXE/A,VXEB,VXEB/A,VXQ4,VXQ4/A,VXQ7,VXQ7/A,VXU,VXU/A,VXU1,VXU1/A,WH,WJ,WJ/A,WKD6,WKD6/A,WKT2,WKT2/A,WKT4,WKT4/A	
13	16220-ZA0-702	SPACER COMP., CARBURETOR	1	-	-	ED3,ED4,ED4/A,ED5,ED5/A,EN,ES,ES1,ES1/A,ES2,ET,ETS,ETX,HA,HAQ,HA2,HA2/A,HH,HHQ4,HHQ4/A,HTX,HX,HX/A,HXQ4,HXQ4/A,LH,LH/A,LHE,LHE4,LHE4/A,LHZ,LJ,LJ/A,LJG,LJG/A,LJG1,LK,LM9,LNJ,LP,LP/A,LSS4,LSX,LSX/A,LT,LT/A,LW,LX,LX/A,LXF,LXQ4,LXQ4/A,LXZ,LX2,LX2/A,PA,PAE,PA2,PA2/A,PMT2,PMT2/A,PX,PX/A,QA,QAE,QAE2,QAE2/A,QAG,QAG/A,QAG2,QAG2/A,QAQ,QAQ4,QA2,QA2/A,QDA,QE,QE/A,QH,QH/A,QHB2,QHC,QHE,QHP1,QHP1/A,QHQ4,QHQ4/A,QHZ,QKA2,QMH,QMH/A,QP,QP/A,QT,QT/A,QW24,QX,QX/A,QXB,QXB7,QXB7/A,QXC,QXC/A,QXC9,QXC9/A,QXE,QXE/A,QXEB,QXE4,QXE4/A,QXQ4,QXQ4/A,QXU,QXU/A,RA,RA2,RA2/A,RH,RHE,RHE4,RHQ4,RHQ4/A,RJ,RJ/A,RSC2,RSS1,RSS1/A,RX,RX/A,RXQ4,RXQ4/A,SE,SE/A,SH,SHE,SHEZ,SJ,SJ/A,SJC,SJC1,SJC1/A,SJC5,SJC5/A,SJG,SJG/A,SJP,SK,SMS,SMS/A,SMX2,SMX2/A,SNE1,SNR,SNR/A,STP,STP/A,STQ,STQ/A,SW,SWE,SX,SX/A,SBX,SXE,SXEB,SXE4,SXE4/A,SXQ4,SXQ4/A,SXU,SXU/A,VA,VAH1,VA2,VA2/A,VH,VH/A,VH12,VH12/A,VMX,VNG,VTA,VTA2,VTA2/A,VX,VX/A,VXB,VXB/A,VXB7,VXB7/A,VXE,VXE/A,VXEB,VXEB/A,VXQ4,VXQ4/A,VXQ7,VXQ7/A,VXU,VXU/A,VXU1,VXU1/A,WH,WJ,WJ/A,WKD6,WKD6/A,WKT2,WKT2/A,WKT4,WKT4/A	
14	16221-ZA0-700	PACKING, CARBURETOR	1	(1)	-	3151974 EN,ET,ETS,ETX,LJ,LK,LKS,LM9,LNJ,LW,LXZ,L1,P1,QT,Q1,RJ,R1,SHEZ,SJ,SJP,SK,SNR,SW,SWE,S1,V1,WJ,W1	
	16221-ZA0-800	1	(1)	-	QDA ED3,ED4,ED4/A,ED5,ED5/A,ES,ES1,ES1/A,ES2,HA,HAQ,HA2,HA2/A,HH,HHQ4,HHQ4/A,HTX,HX,HX/A,HXQ4,HXQ4/A,LH,LH/A,LHE,LHE4,LHE4/A,LHZ,LJ/A,LJG,LJG/A,LJG1,LKS/A,LNZ,LP,LP/A,LSS4,LSS5,LSS5/A,LSX,LSX/A,LT,LT/A,LX,LX/A,LXF,LXQ4,LXQ4/A,LX2,LX2/A,L1,L1/A,PA,PAE,PA2,PA2/A,PMT2,PMT2/A,PX,PX/A,P1,QA,QAE,QAE2,QAE2/A,QAG,QAG/A,QAG2,QAG2/A,QAQ,QAQ4,QA2,QA2/A,QE,QE/A,QH,QH/A,QHB2,QHC,QHE,QHP1,QHP1/A,QHQ4,QHQ4/A,QHZ,QKA2,QMH,QMH/A,QP,QP/A,QT,QT/A,QW24,QX,QX/A,QXB,QXB7,QXB7/A,QXC,QXC/A,QXC9,QXC9/A,QXE,QXE/A,QXEB,QXE4,QXE4/A,QXQ4,QXQ4/A,QXU,QXU/A,Q1,Q1/A,RA,RA2,RA2/A,RH,RHE,RHE4,RHQ4,RHQ4/A,RJ/A,RSC2,RSS1,RSS1/A,RX,RX/A,RXQ4,RXQ4/A,R1,R1/A,SE,SE/A,SH,SHE,SHW,SHW/A,SJ/A,SJC,SJC1,SJC1/A,SJC5,SJC5/A,SJG,SJG/A,SMS,SMS/A,SMX2,SMX2/A,SNE1,SNR/A,STP,STP/A,STQ,STQ/A,SX,SX/A,SBX,SXE,SXEB,SXE4,SXE4/A,SXQ4,SXQ4/A,SXU,SXU/A,VA,VAH1,VA2,VA2/A,VH,VH/A,VH12,VH12/A,VMX,VNG,VTA,VTA2,VTA2/A,VX,VX/A,VXB,VXB/A,VXB7,VXB7/A,VXE,VXE/A,VXEB,VXEB/A,VXQ4,VXQ4/A,VXQ7,VXQ7/A,VXU,VXU/A,VXU1,VXU1/A,V1,WH,WJ/A,WKD6,WKD6/A,WKT2,WKT2/A,WKT4,WKT4/A,W1,W1/A	
			1	(1)	-	3151975 EN,ET,ETS,ETX,LJ,LK,LKS,LM9,LNJ,LW,LXZ,QT,RJ,SHEZ,SJ,SJP,SK,SNR,SW,SWE,S1,S1/A,WJ	

2

E-14-3

CARBURETOR(4)

K 1

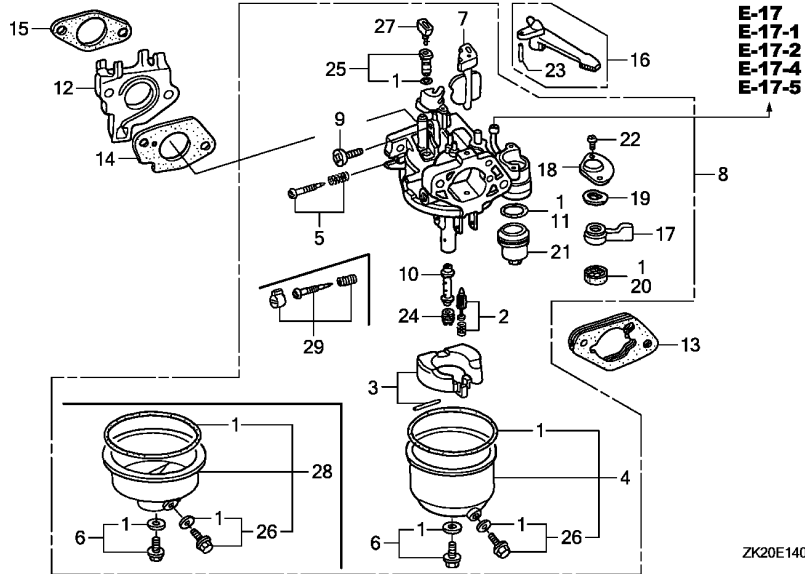

Ref. No.	Part No.	Description	Reqd. QTY			Serial No.	Parts catalogue code
			(1)	(2)	(3)		
15	16223-ZA0-700	PACKING, INSULATOR	1	(1)	-	3151974	EN,ET,ETS,ETX,LJ,LK,LKS,LM9,LNJ,LW,LXZ,L1,P1,QT,Q1,RJ,R1,SHEZ,SJ SJP,SK,SNR,SW,SWE,S1,V1,WJ,W1
	16223-ZA0-800	1	-	-		QDA
			1	(1)	-		ED3,ED4,ED4/A,ED5,ED5/A,ES,ES1,ES1/A,ES2,HA,HAQ,HA2,HA2/A,HH,HHQ4 HHQ4/A,HTX,HX,HX/A,HXQ4,HXQ4/A,LH,LH/A,LHE,LHE4,LHE4/A,LHZ,LJ/A LJG,LJG/A,LJG1,LKS/A,LNZ,LP,LP/A,LSS4,LSS5,LSS5/A,LSX,LSX/A,LT LT/A,LX,LX/A,LXF,LXQ4,LXQ4/A,LX2,LX2/A,L1/A,PA,PAE,PA2,PA2/A,PMT2 PMT2/A,PX,PX/A,QA,QAE,QAE2,QAE2/A,QAG,QAG/A,QAG2,QAG2/A,QAQ,QAQ4 QA2,QA2/A,QE,QE/A,QH,QH/A,QHB2,QHC,QHE,QHP1,QHP1/A,QHQ4,QHQ4/A QHZ,QKA2,QMH,QMH/A,QP,QP/A,QT/A,QW24,QX,QX/A,QXB,QXB7,QXB7/A,QXC QXC/A,QXC9,QXC9/A,QXE,QXE/A,QXEB,QXE4,QXE4/A,QXQ4,QXQ4/A,QXU QXU/A,Q1/A,RA,RA2,RA2/A,RH,RHE,RHE4,RHQ4,RHQ4/A,RJ/A,RSC2,RSS1 RSS1/A,RX,RX/A,RXQ4,RXQ4/A,R1/A,SE,SE/A,SH,SHE,SHW,SHW/A,SJ/A,SJC SJC1,SJC1/A,SJC5,SJC5/A,SJG,SJG/A,SMS,SMS/A,SMX2,SMX2/A,SNE1 SNR/A,STP,STP/A,STQ,STQ/A,SX,SX/A,SXB,SXE,SXEB,SXE4,SXE4/A,SXQ4 SXQ4/A,SXU,SXU/A,VA,VAH1,VA2,VA2/A,VH,VH/A,VH12,VH12/A,VMX,VNG VTA,VTA2,VTA2/A,VX,VX/A,VXB,VXB/A,VXB7,VXB7/A,VXE,VXE/A,VXEB VXEB/A,VXQ4,VXQ4/A,VXQ7,VXQ7/A,VXU,VXU/A,VXU1,VXU1/A,WH,WJ/A,WKD6 WKD6/A,WKT2,WKT2/A,WKT4,WKT4/A,W1/A
			1	(1)	-	3151975	EN,ET,ETS,ETX,LJ,LK,LKS,LM9,LNJ,LW,LXZ,L1,P1,QT,Q1,RJ,R1,SHEZ,SJ SJP,SK,SNR,SW,SWE,S1,S1/A,V1,WJ,W1

Ref. No.	Part No.	Description	Reqd. QTY			Serial No.	Parts catalogue code
			(1)	(2)	(3)		
16	16610-ZE1-000	LEVER COMP., CHOKE (STD.) ...	1	-	-	ED3,ED4,ED4/A,ED5,ED5/A,EN,ES,ES1,ES1/A,ES2,ET,ETS,ETX,HA,HAQ,HA2,HA2/A,HH,HHQ4,HHQ4/A,HTX,HX,HX/A,HXQ4,HXQ4/A,LH,LH/A,LHE,LHE4,LHE4/A,LHZ,LJ,LJ/A,LJG,LJG/A,LJG1,LK,LM9,LNJ,LP,LP/A,LSX,LSX/A,LT,LT/A,LW,LX,LX/A,LXF,LXQ4,LXQ4/A,LXZ,LX2,LX2/A,PA,PAE,PA2,PA2/A,PMT2,PMT2/A,PX,PX/A,QA,QAE,QAE2,QAE2/A,QAG,QAG/A,QAG2,QAG2/A,QAQ,QAQ4,QA2,QA2/A,QDA,QE,QE/A,QH,QH/A,QHB2,QHE,QHP1,QHP1/A,QHQ4,QHQ4/A,QHZ,QKA2,QMH,QMH/A,QP,QP/A,QT,QT/A,QW24,QX,QX/A,QXB,QXB7,QXB7/A,QXC,QXC/A,QXC9,QXC9/A,QXE,QXE/A,QXEB,QXE4,QXE4/A,QXQ4,QXQ4/A,QXU,QXU/A,RA,RA2,RA2/A,RH,RHE,RHE4,RHQ4,RHQ4/A,RJ,RJ/A,RSC2,RSS1,RSS1/A,RX,RX/A,RXQ4,RXQ4/A,SE,SE/A,SH,SHE,SHEZ,SJ,SJ/A,SJC,SJC1,SJC1/A,SJC5,SJC5/A,SJG,SJG/A,SJP,SK,SMS,SMS/A,SMX2,SMX2/A,SNE1,SNR,SNR/A,STP,STP/A,STQ,STQ/A,SW,SWE,SX,SX/A,SXB,SXE,SXE4,SXE4/A,SXQ4,SXQ4/A,SXU,SXU/A,VA,VAH1,VA2,VA2/A,VH,VH/A,VH12,VH12/A,VMX,VNG,VTA,VTA2,VTA2/A,VX,VX/A,VXB,VXB/A,VXB7,VXB7/A,VXE,VXE/A,VXEB,VXEB/A,VXQ4,VXQ4/A,VXQ7,VXQ7/A,VXU,VXU/A,VXU1,VXU1/A,WH,WJ,WJ/A,WKD6,WKD6/A,WKT2,WKT2/A,WKT4,WKT4/A	
			-	(1)	-		
17	16953-ZE1-811	LEVER, COCK (CARBURETOR NO.)	1	(1)	-	BE16D A L1,P1,QHC,QXC,Q1,R1,V1,W1	
		(CARBURETOR NO.)	1	-	-	QDA	
			1	-	-	BE15G A ED3,ED4,ED5,EN,ES,ES1,ET,ETS,ETX,HH,HHQ4,HX,HXQ4,LH,LHE,LHE4,LKS,LP,LW,LX,LXQ4,LXZ,PX,QA,QAE,QAQ4,QE,QH,QHE,QHQ4,QP,QT,QX,QXB,QXE,QXEB,QXE4,QXQ4,RH,RHE,RHE4,RHQ4,RX,RXQ4,SE,SH,SHE,SHEZ,SNE1,SW,SWE,SX,SXB,SXE,SXE4,SXQ4,VH,VNG,VX,VXB,VXE,VXEB,VXQ4,VXU,WH,ED4/A,ED5/A,ES1/A,ES2,HA,HAQ,HA2,HA2/A,HHQ4/A,HTX,HX/A,HXQ4/A,LH/A,LHE4/A,LHZ,LJ,LJ/A,LJG,LJG/A,LJG1,LK,LKS/A,LM9,LNJ,LNZ,LP/A,LSS4,LSS5,LSS5/A,LSX,LSX/A,LT,LT/A,LX/A,LXF,LXQ4/A,LX2,LX2/A,L1/A,PA,PAE,PA2,PA2/A,PMT2,PMT2/A,PX/A,QAE2,QAE2/A,QAG,QAG/A,QAG2,QAG2/A,QAQ,QA2,QA2/A,QE/A,QH/A,QHB2,QHP1,QHP1/A,QHQ4/A,QHZ,QKA2,QMH,QMH/A,QP/A,QT/A,QW24,QX/A,QXB7,QXB7/A,QXC/A,QXC9,QXC9/A,QXE/A,QXE4/A,QXQ4/A,QXU,QXU/A,Q1/A,RA,RA2,RA2/A,RHQ4/A,RJ,RJ/A,RSC2,RSS1,RSS1/A,RX/A,RXQ4/A,R1/A,SE/A,SHW,SHW/A,SJ,SJ/A,SJC,SJC1,SJC1/A,SJC5,SJC5/A,SJG,SJG/A,SJP,SK,SMS,SMS/A,SMX2,SMX2/A,SNR,SNR/A,STP,STP/A,STQ,STQ/A,SX/A,SXE4/A,SXQ4/A,SXU,SXU/A,S1/A,VA,VAH1,VA2,VA2/A,VH/A,VH12,VH12/A,VMX,VTA,VTA2,VTA2/A,VX/A,VXB/A,VXB7,VXB7/A,VXE/A,VXEB/A,VXQ4/A,VXQ7,VXQ7/A,VXU/A,VXU1,VXU1/A,WJ,WJ/A,WKD6,WKD6/A,WKT2,WKT2/A,WKT4,WKT4/A,W1/A	
	16953-ZE1-812	1	(1)	-	BE16D B L1,P1,QHC,QXC,Q1,R1,S1,V1,W1	
		(CARBURETOR NO.)	1	-	-	BE15G B ED3,ED4,ED5,EN,ES,ES1,ET,ETS,ETX,HH,HHQ4,HX,HXQ4,LH,LHE,LHE4,LKS,LP,LW,LX,LXQ4,LXZ,PX,QA,QAE,QAQ4,QE,QH,QHE,QHQ4,QP,QT,QX,QXB,QXE,QXEB,QXE4,QXQ4,RH,RHE,RHE4,RHQ4,RX,RXQ4,SE,SH,SHE,SHEZ,SNE1,SW,SWE,SX,SXB,SXE,SXE4,SXQ4,VH,VNG,VX,VXB,VXE,VXEB,VXQ4,VXU,WH	



E-14-3

CARBURETOR(4)

K 3

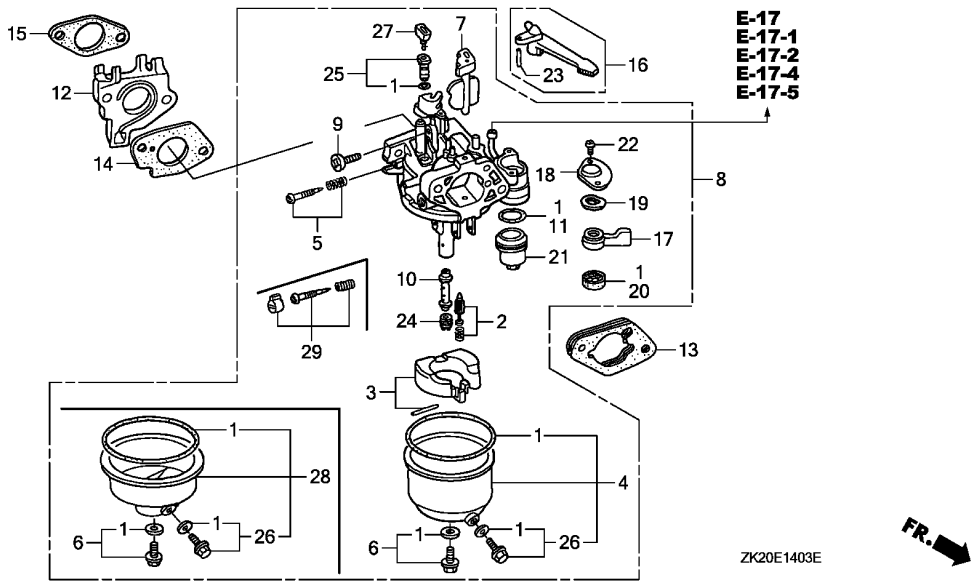

Ref. No.	Part No.	Description	Reqd. QTY			Serial No.	Parts catalogue code
			GX240K1				
			(1)	(2)	(3)		
18	16954-ZE1-812	PLATE, LEVER SETTING	1	-	-	-----	ED3,ED4,ED4/A,ED5,ED5/A,EN,ES,ES1,ES1/A,ES2,ET,ETS,ETX,HA,HA2,HA2/A,HH,HHQ4,HHQ4/A,HTX,HX,HX/A,HXQ4,HXQ4/A,LH,LH/A,LHE,LHE4,LHE4/A,LHZ,LJ,LJ/A,LJG,LJG/A,LJG1,LK,LKS,LKS/A,LM9,LNJ,LNZ,LP,LP/A,LSS4,LSS5,LSS5/A,LSX,LSX/A,LT,LT/A,LW,LX,LX/A,LXF,LXQ4,LXQ4/A,LXZ,LX2,LX2/A,PA,PAE,PA2,PA2/A,PMT2,PMT2/A,PX,PX/A,QA,QAE,QAE2,QAE2/A,QAG,QAG/A,QAG2,QAG2/A,QAQ4,QA2,QA2/A,QDA,QE,QE/A,QH,QH/A,QHB2,QHC,QHE,QHP1,QHP1/A,QHQ4,QHQ4/A,QHZ,QKA2,QMH,QMH/A,QP,QP/A,QT,QT/A,QW24,QX,QX/A,QXB,QXB7,QXB7/A,QXC,QXC/A,QXC9/A,QXE,QXE/A,QXEB,QXE4,QXE4/A,QXQ4,QXQ4/A,QXU,QXU/A,RA,RA2,RA2/A,RH,RHE,RHE4,RHQ4,RHQ4/A,RJ,RJ/A,RSC2,RSS1,RSS1/A,RX,RX/A,RXQ4,RXQ4/A,SE,SE/A,SH,SHE,SHEZ,SHW,SHW/A,SJ,SJ/A,SJC,SJC1,SJC1/A,SJC5,SJC5/A,SJG,SJG/A,SJP,SK,SMS,SMS/A,SMX2,SMX2/A,SNE1,SNR,SNR/A,STP,STP/A,STQ,STQ/A,SW,SWE,SX,SX/A,SXB,SXE,SXEB,SXE4,SXE4/A,SXQ4,SXQ4/A,SXU,SXU/A,VA,VAH1,VA2,VA2/A,VH,VH/A,VH12,VH12/A,VMX,VNG,VTA,VTA2,VTA2/A,VX,VX/A,VXB,VXB/A,VXB7,VXB7/A,VXE,VXE/A,VXEB,VXEB/A,VXQ4,VXQ4/A,VXQ7,VXQ7/A,VXU,VXU/A,VXU1,VXU1/A,WH,WJ,WJ/A,WKD6,WKD6/A,WKT2,WKT2/A,WKT4,WKT4/A
		(CARBURETOR NO.)	1	-	-	BE70A B -----	HAQ,QAQ,QXC9
			-	(1)	-		
	16954-ZFO-841 (CARBURETOR NO.)	1	-	-	-----	BE70A A HAQ,QAQ,QXC9

2

Ref. No.	Part No.	Description	Reqd. QTY			Serial No.	Parts catalogue code
			(1)	(2)	(3)		
19	16956-ZE1-811	SPRING, COCK LEVER	1	-	-	ED3,ED4,ED4/A,ED5,ED5/A,EN,ES,ES1,ES1/A,ES2,ET,ETS,ETX,HA,HAQ,HA2,HA2/A,HH,HHQ4,HHQ4/A,HTX,HX,HX/A,HXQ4,HXQ4/A,LH,LH/A,LHE,LHE4,LHE4/A,LHZ,LJ,LJ/A,LJG,LJG/A,LJG1,LK,LKS,LKS/A,LM9,LNJ,LNZ,LP,LP/A,LSS4,LSS5,LSS5/A,LSX,LSX/A,LT,LT/A,LW,LX,LX/A,LXF,LXQ4,LXQ4/A,LXZ,LX2,LX2/A,PA,PAE,PA2,PA2/A,PMT2,PMT2/A,PX,PX/A,QA,QAE,QAE2,QAE2/A,QAG,QAG/A,QAG2,QAG2/A,QAQ,QAQ4,QA2,QA2/A,QDA,QE,QE/A,QH,QH/A,QHB2,QHC,QHE,QHP1,QHP1/A,QHQ4,QHQ4/A,QHZ,QKA2,QMH,QMH/A,QP,QP/A,QT,QT/A,QW24,QX,QX/A,QXB,QXB7,QXB7/A,QXC,QXC/A,QXC9,QXC9/A,QXE,QXE/A,QXEB,QXE4,QXE4/A,QXQ4,QXQ4/A,QXU,QXU/A,RA,RA2,RA2/A,RH,RHE,RHE4,RHQ4,RHQ4/A,RJ,RJ/A,RSC2,RSS1,RSS1/A,RX,RX/A,RXQ4,RXQ4/A,SE,SE/A,SH,SHE,SHEZ,SHW,SHW/A,SJ,SJ/A,SJC,SJC1,SJC1/A,SJC5,SJC5/A,SJG,SJG/A,SJP,SK,SMS,SMS/A,SMX2,SMX2/A,SNE1,SNR,SNR/A,STP,STP/A,STQ,STQ/A,SW,SWE,SX,SX/A,SBX,SXE,SXEB,SXE4,SXE4/A,SXQ4,SXQ4/A,SXU,SXU/A,VA,VAH1,VA2,VA2/A,VH,VH/A,VH12,VH12/A,VMX,VNG,VTA,VTA2,VTA2/A,VX,VX/A,VXB,VXB/A,VXB7,VXB7/A,VXE,VXE/A,VXEB,VXEB/A,VXQ4,VXQ4/A,VXQ7,VXQ7/A,VXU,VXU/A,VXU1,VXU1/A,WH,WJ,WJ/A,WKD6,WKD6/A,WKT2,WKT2/A,WKT4,WKT4/A	
			-	(1)	-		
20	16957-ZE1-812	PACKING, FUEL COCK	1	-	-	ED3,ED4,ED4/A,ED5,ED5/A,EN,ES,ES1,ES1/A,ES2,ET,ETS,ETX,HA,HAQ,HA2,HA2/A,HH,HHQ4,HHQ4/A,HTX,HX,HX/A,HXQ4,HXQ4/A,LH,LH/A,LHE,LHE4,LHE4/A,LHZ,LJ,LJ/A,LJG,LJG/A,LJG1,LK,LKS,LKS/A,LM9,LNJ,LNZ,LP,LP/A,LSS4,LSS5,LSS5/A,LSX,LSX/A,LT,LT/A,LW,LX,LX/A,LXF,LXQ4,LXQ4/A,LXZ,LX2,LX2/A,PA,PAE,PA2,PA2/A,PMT2,PMT2/A,PX,PX/A,QA,QAE,QAE2,QAE2/A,QAG,QAG/A,QAG2,QAG2/A,QAQ,QAQ4,QA2,QA2/A,QDA,QE,QE/A,QH,QH/A,QHB2,QHC,QHE,QHP1,QHP1/A,QHQ4,QHQ4/A,QHZ,QKA2,QMH,QMH/A,QP,QP/A,QT,QT/A,QW24,QX,QX/A,QXB,QXB7,QXB7/A,QXC,QXC/A,QXC9,QXC9/A,QXE,QXE/A,QXEB,QXE4,QXE4/A,QXQ4,QXQ4/A,QXU,QXU/A,RA,RA2,RA2/A,RH,RHE,RHE4,RHQ4,RHQ4/A,RJ,RJ/A,RSC2,RSS1,RSS1/A,RX,RX/A,RXQ4,RXQ4/A,SE,SE/A,SH,SHE,SHEZ,SHW,SHW/A,SJ,SJ/A,SJC,SJC1,SJC1/A,SJC5,SJC5/A,SJG,SJG/A,SJP,SK,SMS,SMS/A,SMX2,SMX2/A,SNE1,SNR,SNR/A,STP,STP/A,STQ,STQ/A,SW,SWE,SX,SX/A,SBX,SXE,SXEB,SXE4,SXE4/A,SXQ4,SXQ4/A,SXU,SXU/A,VA,VAH1,VA2,VA2/A,VH,VH/A,VH12,VH12/A,VMX,VNG,VTA,VTA2,VTA2/A,VX,VX/A,VXB,VXB/A,VXB7,VXB7/A,VXE,VXE/A,VXEB,VXEB/A,VXQ4,VXQ4/A,VXQ7,VXQ7/A,VXU,VXU/A,VXU1,VXU1/A,WH,WJ,WJ/A,WKD6,WKD6/A,WKT2,WKT2/A,WKT4,WKT4/A	
			-	(1)	-		
21	16967-ZE0-811	CUP, FUEL STRAINER	1	-	-	ED3,ED4,ED4/A,ED5,ED5/A,EN,ES,ES1,ES1/A,ES2,ET,ETS,ETX,HA,HAQ,HA2,HA2/A,HH,HHQ4,HHQ4/A,HTX,HX,HX/A,HXQ4,HXQ4/A,LH,LH/A,LHE,LHE4,LHE4/A,LHZ,LJ,LJ/A,LJG,LJG/A,LJG1,LK,LKS,LKS/A,LM9,LNJ,LNZ,LP,LP/A,LSS4,LSS5,LSS5/A,LSX,LSX/A,LT,LT/A,LW,LX,LX/A,LXF,LXQ4,LXQ4/A,LXZ,LX2,LX2/A,PA,PAE,PA2,PA2/A,PMT2,PMT2/A,PX,PX/A,QA,QAE,QAE2,QAE2/A,QAG,QAG/A,QAG2,QAG2/A,QAQ,QAQ4,QA2,QA2/A,QDA,QE,QE/A,QH,QH/A,QHB2,QHC,QHE,QHP1,QHP1/A,QHQ4,QHQ4/A,QHZ,QKA2,QMH,QMH/A,QP,QP/A,QT,QT/A,QW24,QX,QX/A,QXB,QXB7,QXB7/A,QXC,QXC/A,QXC9,QXC9/A,QXE,QXE/A,QXEB,QXE4,QXE4/A,QXQ4,QXQ4/A,QXU,QXU/A,RA,RA2,RA2/A,RH,RHE,RHE4,RHQ4,RHQ4/A,RJ,RJ/A,RSC2,RSS1,RSS1/A,RX,RX/A,RXQ4,RXQ4/A,SE,SE/A,SH,SHE,SHEZ,SHW,SHW/A,SJ,SJ/A,SJC,SJC1,SJC1/A,SJC5,SJC5/A,SJG,SJG/A,SJP,SK,SMS,SMS/A,SMX2,SMX2/A,SNE1,SNR,SNR/A,STP,STP/A,STQ,STQ/A,SW,SWE,SX,SX/A,SBX,SXE,SXEB,SXE4,SXE4/A,SXQ4,SXQ4/A,SXU,SXU/A,VA,VAH1,VA2,VA2/A,VH,VH/A,VH12,VH12/A,VMX,VNG,VTA,VTA2,VTA2/A,VX,VX/A,VXB,VXB/A,VXB7,VXB7/A,VXE,VXE/A,VXEB,VXEB/A,VXQ4,VXQ4/A,VXQ7,VXQ7/A,VXU,VXU/A,VXU1,VXU1/A,WH,WJ,WJ/A,WKD6,WKD6/A,WKT2,WKT2/A,WKT4,WKT4/A	
			-	(1)	-		



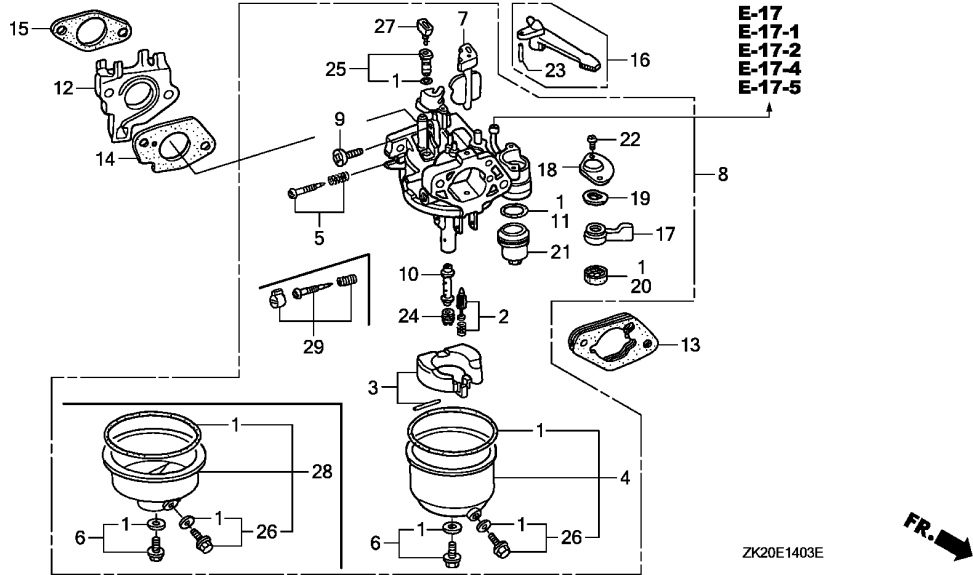

Ref. No.	Part No.	Description	Reqd. QTY			Serial No.	Parts catalogue code
			GX240K1	(1)	(2)		
22	93500-03008-1G	SCREW, PAN, 3X8 (CARBURETOR NO.)	2	(2)	-	BE15G A	ED3,ED4,ED5,EN,ES,ES1,ET,ETS,ETX,HH,HHQ4,HTX,HX,HXQ4,LH,LHE,LHE4,LJ,LJG,LK,LKS,LM9,LNJ,LNZ,LP,LW,LX,LXQ4,LXZ,L1,PX,P1,QA,QAE,QAQ4,QE,QH,QHE,QHQ4,QP,QT,QX,QXB,QXE,QXEB,QXE4,QXQ4,Q1,RH,RHE,RHE4,RHQ4,RJ,RX,RXQ4,R1,SE,SH,SHE,SHEZ,SJ,SJC,SJG,SJP,SK,SMS,SNE1,SNR,STP,STQ,SW,SWE,SX,SXB,SXE,SXEB,SXE4,SXQ4,S1,VH,VNG,VX,VXB,VXE,VXEB,VXQ4,VXU,V1,WH,WJ,W1
		(CARBURETOR NO.)	2	-	-	-----	QDA
	93500-03006-1H	SCREW, PAN, 3X6 (CARBURETOR NO.)	2	(2)	-	BE16D A	QHC,QXC ED4/A,ED5/A,ES1/A,ES2,HA,HAQ,HA2,HA2/A,HHQ4/A,HX/A,HXQ4/A,LH/A,LHE4/A,LHZ,LJ/A,LJG/A,LJG1,LKS/A,LP/A,LSS4,LSS5,LS55/A,LSX,LSX/A,LT,LT/A,LX/A,LXF,LXQ4/A,LX2,LX2/A,L1/A,PA,PAE,PA2,PA2/A,PMT2,PMT2/A,PX/A,QAE2,QAE2/A,QAG,QAG/A,QAG2,QAG2/A,QAQ,QA2,QA2/A,QE/A,QH/A,QHB2,QHP1,QHP1/A,QHQ4/A,QHZ,QKA2,QMH,QMH/A,QP/A,QT/A,QW24,QX/A,QXB7,QXB7/A,QXC/A,QXC9,QXC9/A,QXE/A,QXE4/A,QXQ4/A,QXU,QXU/A,Q1/A,RA,RA2,RA2/A,RHQ4/A,RJ/A,RSC2,RSS1,RSS1/A,RX/A,RXQ4/A,R1/A,SE/A,SHW,SHW/A,SJ/A,SJC1,SJC1/A,SJC5,SJC5/A,SJG/A,SMS/A,SMX2,SMX2/A,SNR/A,STP/A,STQ/A,SX/A,SXE4/A,SXQ4/A,SXU,SXU/A,S1/A,VA,VAH1,VA2,VA2/A,VH/A,VH12,VH12/A,VMX,VTA,VTA2,VTA2/A,VX/A,VXB/A,VXB7,VXB7/A,VXE/A,VXEB/A,VXQ4/A,VXQ7,VXQ7/A,VXU/A,VXU1/A,WJ/A,WKD6,WKD6/A,WKT2,WKT2/A,WKT4,WKT4/A,W1/A
		(CARBURETOR NO.)	2	(2)	-	BE15G B	ED3,ED4,ED5,EN,ES,ES1,ET,ETS,ETX,HH,HHQ4,HTX,HX,HXQ4,LH,LHE,LHE4,LJ,LJG,LK,LKS,LM9,LNJ,LNZ,LP,LW,LX,LXQ4,LXZ,L1,PX,P1,QA,QAE,QAQ4,QE,QH,QHE,QHQ4,QP,QT,QX,QXB,QXE,QXEB,QXE4,QXQ4,Q1,RH,RHE,RHE4,RHQ4,RJ,RX,RXQ4,R1,SE,SH,SHE,SHEZ,SJ,SJC,SJG,SJP,SK,SMS,SNE1,SNR,STP,STQ,SW,SWE,SX,SXB,SXE,SXEB,SXE4,SXQ4,S1,VH,VNG,VX,VXB,VXE,VXEB,VXQ4,VXU,V1,WH,WJ,W1
		..	2	-	-	BE16D B	QHC,QXC

Ref. No.	Part No.	Description	Reqd. QTY			Serial No.	Parts catalogue code
			(1)	(2)	(3)		
23	94305-20122	PIN, SPRING, 2X12	1	-	-	ED3,ED4,ED4/A,ED5,ED5/A,EN,ES,ES1,ES1/A,ES2,ET,ETS,ETX,HA,HAQ,HA2,HA2/A,HH,HHQ4,HHQ4/A,HTX,HX,HX/A,HXQ4,HXQ4/A,LH,LH/A,LHE,LHE4,LHE4/A,LHZ,LJ,LJ/A,LJG,LJG/A,LJG1,LK,LM9,LNJ,LP,LP/A,LSX,LSX/A,LT,LT/A,LW,LX,LX/A,LXF,LXQ4,LXQ4/A,LXZ,LX2,LX2/A,PA,PAE,PA2,PA2/A,PMT2,PMT2/A,PX,PX/A,QA,QAE,QAE2,QAE2/A,QAG,QAG/A,QAG2,QAG2/A,QAQ,QAQ4,QA2,QA2/A,QDA,QE,QE/A,QH,QH/A,QHB2,QHE,QHP1,QHP1/A,QHQ4,QHQ4/A,QHZ,QKA2,QMH,QMH/A,QP,QP/A,QT,QT/A,QW24,QX,QX/A,QXB,QXB7,QXB7/A,QXC,QXC/A,QXC9,QXC9/A,QXE,QXE/A,QXEB,QXE4,QXE4/A,QXQ4,QXQ4/A,QXU,QXU/A,RA,RA2,RA2/A,RH,RHE,RHE4,RHQ4,RHQ4/A,RJ,RJ/A,RSC2,RSS1,RSS1/A,RX,RX/A,RXQ4,RXQ4/A,SE,SE/A,SH,SHE,SHEZ,SJ,SJ/A,SJC,SJC1,SJC1/A,SJC5,SJC5/A,SJG,SJG/A,SJP,SK,SMS,SMS/A,SMX2,SMX2/A,SNE1,SNR,SNR/A,STP,STP/A,STQ,STQ/A,SW,SWE,SX,SX/A,SXB,SXE,SXEB,SXE4,SXE4/A,SXQ4,SXQ4/A,SXU,SXU/A,VA,VAH1,VA2,VA2/A,VH,VH/A,VH12,VH12/A,VMX,VNG,VTA,VTA2,VTA2/A,VX,VX/A,VXB,VXB/A,VXB7,VXB7/A,VXE,VXE/A,VXEB,VXEB/A,VXQ4,VXQ4/A,VXQ7,VXQ7/A,VXU,VXU/A,VXU1,VXU1/A,WH,WJ,WJ/A,WKD6,WKD6/A,WKT2,WKT2/A,WKT4,WKT4/A	
24	99101-ZF5-0800	JET, MAIN, #80	-	(1)	-		
		(CARBURETOR NO.)	(1)	(1)	-	BE15G A ED3,ED4,ED5,EN,ES,ES1,ET,ETS,ETX,HA,HH,HHQ4,HTX,HX,HXQ4,LH,LHE,LHE4,LJ,LJG,LK,LKS,LM9,LNJ,LNZ,LP,LW,LX,LXQ4,LXZ,L1,PA,PAE,PX,P1,QA,QAE,QAQ4,QE,QH,QHE,QHQ4,QP,QT,QX,QXB,QXE,QXEB,QXE4,QXQ4,Q1,RA,RH,RHE,RHE4,RHQ4,RJ,RX,RXQ4,R1,SE,SH,SHE,SHEZ,SJ,SJC,SJG,SJP,SK,SMS,SNE1,SNR,STP,STQ,SW,SWE,SX,SXB,SXE,SXEB,SXE4,SXQ4,S1,VA,VAH1,VH,VNG,VTA,VX,VXB,VXE,VXEB,VXQ4,VXU,V1,WH,WJ,W1	
	99101-ZF5-0820	JET, MAIN, #82	(1)	-	-	QDA	
		(CARBURETOR NO.)	(1)	(1)	-	BE15G A ED3,ED4,ED5,EN,ES,ES1,ET,ETS,ETX,HA,HH,HHQ4,HTX,HX,HXQ4,LH,LHE,LHE4,LJ,LJG,LK,LKS,LM9,LNJ,LNZ,LP,LW,LX,LXQ4,LXZ,L1,PA,PAE,PX,P1,QA,QAE,QAQ4,QE,QH,QHE,QHQ4,QP,QT,QX,QXB,QXE,QXEB,QXE4,QXQ4,Q1,RA,RH,RHE,RHE4,RHQ4,RJ,RX,RXQ4,R1,SE,SH,SHE,SHEZ,SJ,SJC,SJG,SJP,SK,SMS,SNE1,SNR,STP,STQ,SW,SWE,SX,SXB,SXE,SXEB,SXE4,SXQ4,S1,VA,VAH1,VH,VNG,VTA,VX,VXB,VXE,VXEB,VXQ4,VXU,V1,WH,WJ,W1	
	99101-ZF5-0850	JET, MAIN, #85	(1)	-	-	QDA	
		(CARBURETOR NO.)	1	1	-	BE15G A ED3,ED4,ED5,EN,ES,ES1,ET,ETS,ETX,HA,HH,HHQ4,HTX,HX,HXQ4,LH,LHE,LHE4,LJ,LJG,LK,LKS,LM9,LNJ,LNZ,LP,LW,LX,LXQ4,LXZ,L1,PA,PAE,PX,P1,QA,QAE,QAQ4,QE,QH,QHE,QHQ4,QP,QT,QX,QXB,QXE,QXEB,QXE4,QXQ4,Q1,RA,RH,RHE,RHE4,RHQ4,RJ,RX,RXQ4,R1,SE,SH,SHE,SHEZ,SJ,SJC,SJG,SJP,SK,SMS,SNE1,SNR,STP,STQ,SW,SWE,SX,SXB,SXE,SXEB,SXE4,SXQ4,S1,VA,VAH1,VH,VNG,VTA,VX,VXB,VXE,VXEB,VXQ4,VXU,V1,WH,WJ,W1	
	99101-ZF5-0880	JET, MAIN, #88	1	-	-	QDA	
		(CARBURETOR NO.)	(1)	(1)	-	BE16D A L1,P1,QHC,QXC,Q1,R1,V1,W1	
	99101-ZF5-0900	JET, MAIN, #90	-	(1)	-	S1,S1/A	
		(CARBURETOR NO.)	(1)	(1)	-	BE16D A L1,P1,QHC,QXC,Q1,R1,V1,W1	
	99101-ZF5-0920	JET, MAIN, #92	-	(1)	-	S1,S1/A	
		(CARBURETOR NO.)	1	1	-	BE16D A L1,P1,QHC,QXC,Q1,R1,V1,W1	
			-	1	-	S1,S1/A	



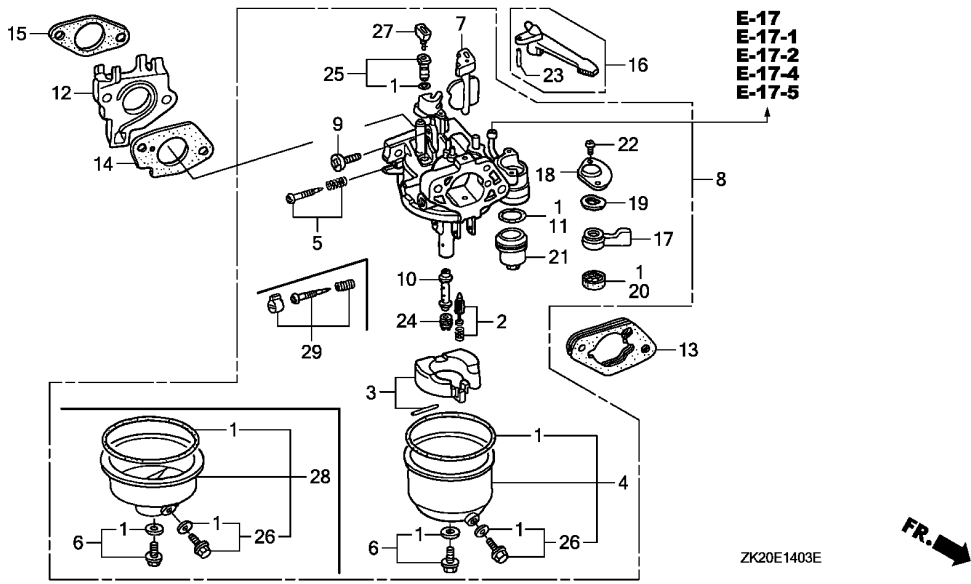

Ref. No.	Part No.	Description	Reqd. QTY			Serial No.	Parts catalogue code
			GX240K1				
			(1)	(2)	(3)		
24)	99101-ZH8-0800	JET, MAIN, #80	(1)	(1)	-	-----	ES1/A,ES2,LJ/A,LJG/A,LJG1,LKS/A,LP/A,LSS5,LSS5/A,LT,LT/A,L1/A QE/A,QP/A,QT/A,Q1/A,RJ/A,RSS1,RSS1/A,R1/A,SE/A,SHW,SHW/A,SJ/A SJC1,SJC1/A,SJC5,SJC5/A,SJG/A,SMS/A,S1/A,WJ/A,W1/A EN,ES,ES1,ET,ETS,ETX,HA,HH,HTX,LJ,LJG,LK,LKS,LM9,LNJ,LNZ,LP,LW LXZ,L1,PA,PAE,P1,QA,QAE,QE,QHE,QP,QT,QXB,QXEB,Q1,RA,RH,RHE,RHE4 RJ,R1,SE,SH,SHEZ,SJ,SJC,SJG,SJP,SK,SMS,SNE1,SW,SWE,SBX,SXE,SXEB S1,VA,VAH1,VNG,VTA,V1,WH,WJ,W1
		(CARBURETOR NO.)	(1)	(1)	-	BE15G B	-----
		//	(1)	-	-	BE15G B	-----
		//	(1)	-	-	BE15G B	BE15G B
		//	(1)	-	-	BE15G B	BE15G B
	99101-ZH8-0820	JET, MAIN, #82	(1)	(1)	-	-----	ES1/A,ES2,LJ/A,LJG/A,LJG1,LKS/A,LP/A,LSS5,LSS5/A,LT,LT/A,L1/A QE/A,QP/A,QT/A,Q1/A,RJ/A,RSS1,RSS1/A,R1/A,SE/A,SHW,SHW/A,SJ/A SJC1,SJC1/A,SJC5,SJC5/A,SJG/A,SMS/A,S1/A,WJ/A,W1/A ED3,ED4,ED5,EN,ES,ES1,ET,ETS,ETX,HA,HH,HHQ4,HTX,HX,HXQ4,LH,LHE LHE4,LJ,LJG,LK,LKS,LM9,LNJ,LNZ,LP,LW,LX,LXQ4,LXZ,L1,PA,PAE,PX,P1 QA,QAE,QAQ4,QE,QH,QHE,QHQ4,QP,QT,QX,QXB,QXE,QXEB,QXE4,QXQ4,Q1,RA RH,RHE,RHE4,RHQ4,RJ,RX,RXQ4,R1,SE,SH,SHE,SHEZ,SJ,SJC,SJG,SJP,SK SMS,SNE1,SNR,STP,STQ,SW,SWE,SX,SBX,SXE,SXEB,SXE4,SXQ4,S1,VA,VAH1 VH,VNG,VTA,VX,VXB,VXE,VXEB,VXQ4,VXU,V1,WH,WJ,W1
		(CARBURETOR NO.)	(1)	(1)	-	BE15G B	-----
		//	(1)	-	-	BE15G B	-----
		//	(1)	-	-	BE15G B	BE15G B
		//	(1)	-	-	BE15G B	BE15G B

2

Ref. No.	Part No.	Description	Reqd. QTY			Serial No.	Parts catalogue code
			(1)	(2)	(3)		
24)	99101-ZH8-0850	JET, MAIN, #85 (CARBURETOR NO.)	1	(1)	-	BE15G B	EN,ES,ES1,ET,ETS,ETX,HA,HH,HTX,LJ,LJG,LK,LKS,LM9,LNJ,LNZ,LP,LW,LXZ,L1,PA,PAE,P1,QA,QAE,QE,QHE,QP,QT,QXB,QXEB,Q1,RA,RH,RHE,RHE4,RJ,R1,SE,SH,SHEZ,SJ,SJC,SJG,SJP,SK,SMS,SNE1,SW,SWE,SXB,SXE,SXEB,S1,VA,VAH1,VNG,VTA,V1,WH,WJ,W1
		(CARBURETOR NO.)	1	-	-		ES1/A,ES2,LJ/A,LJG/A,LJG1,LKS/A,LP/A,LSS5,LSS5/A,LT,LT/A,QE/A,QP/A,QT/A,RJ/A,RSS1,RSS1/A,SE/A,SHW,SHW/A,SJ/A,SJC1,SJC1/A,SJC5,SJC5/A,SJG/A,SMS/A,WJ/A
		(CARBURETOR NO.)	1	-	-	BE15G B	LHZ,LSX,QHP1,QHZ,QMH,QXU,SXU,VMX,VXU1
		//	1	-	-	BE15G B	ED3,ED4,ED5,HHQ4,HX,HXQ4,LH,LHE,LHE4,LX,LXQ4,PX,QAQ4,QH,QHQ4,QX,QXE,QXE4,QXQ4,RHQ4,RX,RXQ4,SHE,SNR,STP,STQ,SX,SXE4,SXQ4,VH,VX,VXB,VXE,VXEB,VXQ4,VXU
			-	(1)	-		L1/A,Q1/A,R1/A,S1/A,W1/A
	99101-ZH8-0880	JET, MAIN, #88 (CARBURETOR NO.)	(1)	(1)	-		LSS4,L1/A,Q1/A,R1/A,W1/A
	99101-ZH8-0900	JET, MAIN, #90 (CARBURETOR NO.)	(1)	(1)	-	BE16D B	L1,P1,QHC,QXC,Q1,R1,V1,W1
	99101-ZH8-0920	JET, MAIN, #92 (CARBURETOR NO.)	1	(1)	-	BE16D B	LSS4,L1/A,Q1/A,R1/A,W1/A
	99101-ZH8-0820	JET, MAIN, #82 (CARBURETOR NO.)	1	(1)	-	BE16D B	L1,P1,QHC,QXC,Q1,R1,V1,W1
			(1)	-	-		ED4/A,ED5/A,HA2/A,HHQ4/A,HX/A,HXQ4/A,LH/A,LHE4/A,LSX/A,LX/A,LXF,LXQ4/A,LX2/A,PA2/A,PMT2/A,PX/A,QAE2/A,QAG,QAG/A,QAG2/A,QA2/A,QH/A,QHB2,QHP1/A,QHQ4/A,QKA2,QMH/A,QW24,QX/A,QXB7,QXB7/A,QXE/A,QXE4/A,QXQ4/A,QXU/A,RA2/A,RHQ4/A,RX/A,RXQ4/A,SMX2/A,SNR/A,STP/A,STQ/A,SX/A,SXE4/A,SXQ4/A,SXU/A,VA2/A,VH/A,VH12/A,VTA2,VTA2/A,VX/A,VXB/A,VXB7,VXB7/A,VXE/A,VXEB/A,VXQ4/A,VXQ7,VXQ7/A,VXU/A,VXU1/A,WKD6,WKD6/A,WKT2/A,WKT4,WKT4/A
	99101-ZH8-0850	JET, MAIN, #85 (CARBURETOR NO.)	1	-	-		ES2
			(1)	-	-		ED4/A,ED5/A,HA2/A,HHQ4/A,HX/A,HXQ4/A,LH/A,LHE4/A,LSX/A,LX/A,LXF,LXQ4/A,LX2/A,PA2/A,PMT2/A,PX/A,QAE2/A,QAG,QAG/A,QAG2/A,QA2/A,QH/A,QHB2,QHP1/A,QHQ4/A,QKA2,QMH/A,QW24,QX/A,QXB7,QXB7/A,QXE/A,QXE4/A,QXQ4/A,QXU/A,RA2/A,RHQ4/A,RX/A,RXQ4/A,SMX2/A,SNR/A,STP/A,STQ/A,SX/A,SXE4/A,SXQ4/A,SXU/A,VA2/A,VH/A,VH12/A,VTA2,VTA2/A,VX/A,VXB/A,VXB7,VXB7/A,VXE/A,VXEB/A,VXQ4/A,VXQ7,VXQ7/A,VXU/A,VXU1/A,WKD6,WKD6/A,WKT2/A,WKT4,WKT4/A
		(CARBURETOR NO.)	(1)	-	-	BE70B B	ED3,ED4,ED5,HHQ4,HX,HXQ4,LH,LHE,LHE4,LHZ,LSX,LX,LXQ4,PX,QAQ4,QH,QHP1,QHQ4,QHZ,QMH,QX,QXE,QXE4,QXQ4,QXU,RHQ4,RX,RXQ4,SHE,SNR,STP,STQ,SX,SXE4,SXQ4,SXU,VH,VMX,VX,VXB,VXE,VXEB,VXQ4,VXU,VXU1
	99101-ZH8-0880	JET, MAIN, #88 (CARBURETOR NO.)	1	-	-		ED4/A,ED5/A,HA2/A,HHQ4/A,HX/A,HXQ4/A,LH/A,LHE4/A,LSX/A,LX/A,LXF,LXQ4/A,LX2/A,PA2/A,PMT2/A,PX/A,QAE2/A,QAG,QAG/A,QAG2/A,QA2/A,QH/A,QHB2,QHP1/A,QHQ4/A,QKA2,QMH/A,QW24,QX/A,QXB7,QXB7/A,QXE/A,QXE4/A,QXQ4/A,QXU/A,RA2/A,RHQ4/A,RX/A,RXQ4/A,SMX2/A,SNR/A,STP/A,STQ/A,SX/A,SXE4/A,SXQ4/A,SXU/A,VA2/A,VH/A,VH12/A,VTA2,VTA2/A,VX/A,VXB/A,VXB7,VXB7/A,VXE/A,VXEB/A,VXQ4/A,VXQ7,VXQ7/A,VXU/A,VXU1/A,WKD6,WKD6/A,WKT2/A,WKT4,WKT4/A
		(CARBURETOR NO.)	1	-	-	BE70B B	ED3,ED4,ED5,HHQ4,HX,HXQ4,LH,LHE,LHE4,LHZ,LSX,LX,LXQ4,PX,QAQ4,QH,QHP1,QHQ4,QHZ,QMH,QX,QXE,QXE4,QXQ4,QXU,RHQ4,RX,RXQ4,SHE,SNR,STP,STQ,SX,SXE4,SXQ4,SXU,VH,VMX,VX,VXB,VXE,VXEB,VXQ4,VXU,VXU1
	99101-ZH7-0820	JET, MAIN, #82 (CARBURETOR NO.)	(1)	-	-	BE70B A	HA2,LX2,PA2,PMT2,QAE2,QAG2,QA2,RA2,RSC2,SMX2,VA2,VH12,WKT2
	99101-ZH7-0850	JET, MAIN, #85 (CARBURETOR NO.)	(1)	-	-	BE70B A	HA2,LX2,PA2,PMT2,QAE2,QAG2,QA2,RA2,RSC2,SMX2,VA2,VH12,WKT2
	99101-ZH7-0880	JET, MAIN, #88 (CARBURETOR NO.)	1	-	-	BE70B A	HA2,LX2,PA2,PMT2,QAE2,QAG2,QA2,RA2,RSC2,SMX2,VA2,VH12,WKT2
		//	(1)	-	-	BE70A A	HAQ,QAQ,QXC9
	99101-ZH7-0900	JET, MAIN, #90 (CARBURETOR NO.)	(1)	-	-	BE70A A	HAQ,QAQ,QXC9
	99101-ZH7-0920	JET, MAIN, #92 (CARBURETOR NO.)	1	-	-	BE70A A	HAQ,QAQ,QXC9



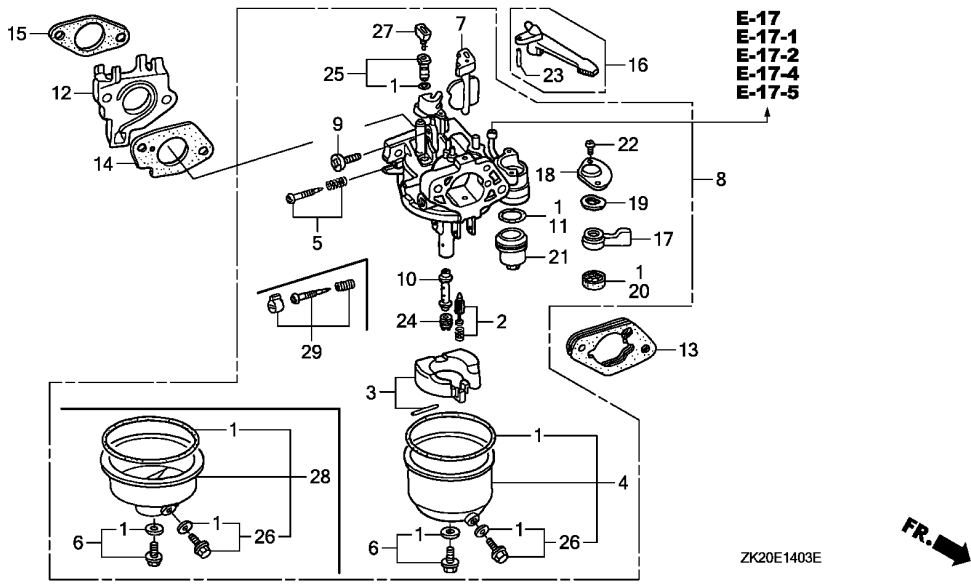

Ref. No.	Part No.	Description	Reqd. QTY			Serial No.	Parts catalogue code
			(1)	(2)	(3)		
			GX240K1				
24)	99101-ZH8-0820	JET, MAIN, #82 (CARBURETOR NO.)	(1)	-	-	BE70B B	HA2,LX2,PA2,PMT2,QAE2,QAG2,QA2,RA2,RSC2,SMX2,VA2,VH12,WKT2
	99101-ZH8-0850	JET, MAIN, #85 (CARBURETOR NO.)	1	-	-	BE70B B	ES2
	99101-ZH8-0880	JET, MAIN, #88 (CARBURETOR NO.)	(1)	-	-	BE70B B	HA2,LX2,PA2,PMT2,QAE2,QAG2,QA2,RA2,RSC2,SMX2,VA2,VH12,WKT2
		(CARBURETOR NO.)	(1)	-	-	BE70B B	HA2,LX2,PA2,PMT2,QAE2,QAG2,QA2,RA2,RSC2,SMX2,VA2,VH12,WKT2
	99101-ZH8-0900	JET, MAIN, #90 (CARBURETOR NO.)	(1)	-	-	BE70A B	HAQ,QAQ,QXC9
	99101-ZH8-0920	JET, MAIN, #92 (CARBURETOR NO.)	(1)	-	-	BE70A B	HAQ,QAQ,QXC9
25	99204-ZE0-0380	JET SET, PILOT, #38 (CARBURETOR NO.)	1	-	-	BE70A B	HAQ,QAQ,QXC9
		(CARBURETOR NO.)	1	-	-	BE70A B	HAQ,QAQ,QXC9
	99204-ZE0-0400	JET SET, PILOT, #40 (CARBURETOR NO.)	1	-	-	BE70A B	HAQ,QAQ,QXC9
		..	1	-	-	BE70B B	ED3,ED4,ED5,HA2,HHQ4,HX,HXQ4,LH,LHE,LHE4,LHZ,LSX,LX,LXQ4,LX2,PA2,PMT2,PX,QAE2,QAG2,QAQ4,QA2,QH,QHP1,QHQ4,QHZ,QMH,QX,QXE,QXE4,QXQ4,QXU,RA2,RHQ4,RSC2,RX,RXQ4,SHE,SMX2,SNR,STP,STQ,SX,SXE4,SXQ4,SXU,VA2,VH,VH12,VMX,VX,VXB,VXE,VXEB,VXQ4,VXU,VXU1,WKT2

2

Ref. No.	Part No.	Description	Reqd. QTY			Serial No.	Parts catalogue code
			(1)	(2)	(3)		
25)	99204-ZE2-0380	JET SET, PILOT, #38	1	-	-	-----	EN,ES,ES1,ES1/A,ES2,ET,ETS,ETX,HA,HH,HTX,LJ,LJ/A,LJG,LJG/A,LJG1 LK,LKS,LKS/A,LM9,LNJ,LNZ,LP,LP/A,LSS5,LSS5/A,LT,LT/A,LW,LXZ,PA PAE,QA,QAQ,QAQ/A,QE,QAQ/A,QHE,QP,QP/A,QT,QT/A,QXB,QXEB,RA,RH,RHE RHE4,RJ,RJ/A,RSS1,RSS1/A,SE,SE/A,SH,SHEZ,SHW,SHW/A,SJ,SJ/A,SJC SJC1,SJC1/A,SJC5,SJC5/A,SJG,SJG/A,SJP,SK,SMS,SMS/A,SNE1,SW,SWE SXB,SXE,SXEB,VA,VAH1,VNG,VTA,WH,WJ,WJ/A
		(CARBURETOR NO.)	1	-	-	-----	BE15G B LSX,SNR,STP,STQ
		//	1	-	-	-----	BE70B A ED3,ED4,ED5,HHQ4,HX,HXQ4,LH,LHE,LHE4,LHZ,LX,LXQ4,PX,QAQ4,QH,QHP1 QHQ4,QHZ,QMH,QX,QXE,QXE4,QXQ4,QXU,RHQ4,RX,RXQ4,SHE,SX,SXE4,SXQ4 SXU,VH,VMX,VX,VXB,VXE,VXEB,VXQ4,VXU,VXU1
			-	(1)	-		
	99204-ZE2-0400	JET SET, PILOT, #40	1	-	-	-----	BE70B A HA2,LX2,PA2,PMT2,QAQ2,QA2,QA2,RA2,RSC2,SMX2,VA2,VH12,WKT2
	99204-ZA0-0400 (CARBURETOR NO.)	1	-	-	-----	BE70B C ED3,ED4,ED4/A,ED5,ED5/A,HA2,HA2/A,HHQ4,HHQ4/A,HX,HX/A,HXQ4,HXQ4/A LH,LH/A,LHE,LHE4,LHE4/A,LHZ,LSX,LSX/A,LX,LX/A,LXF,LXQ4,LXQ4/A,LX2 LX2/A,PA2,PA2/A,PMT2,PMT2/A,PX,PX/A,QAQ2,QAQ2/A,QAG,QAQ/A,QAG2 QAQ2/A,QAQ4,QA2,QA2/A,QH,QH/A,QHB2,QHP1,QHP1/A,QHQ4,QHQ4/A,QHZ QKA2,QMH,QMH/A,QW24,QX,QX/A,QXB7,QXB7/A,QXE,QXE/A,QXE4,QXE4/A QXQ4,QXQ4/A,QXU,QXU/A,RA2,RA2/A,RHQ4,RHQ4/A,RSC2,RX,RX/A,RXQ4 RXQ4/A,SHE,SMX2,SMX2/A,SNR,SNR/A,STP,STP/A,STQ,STQ/A,SX,SX/A,SXE4 SXE4/A,SXQ4,SXQ4/A,SXU,SXU/A,VA2,VA2/A,VH,VH/A,VH12,VH12/A,VMX VTA2,VTA2/A,VX,VX/A,VXB,VXB/A,VXB7,VXB7/A,VXE,VXE/A,VXEB,VXEB/A VXQ4,VXQ4/A,VXQ7,VXQ7/A,VXU,VXU/A,VXU1,VXU1/A,WKD6,WKD6/A,WKT2 WKT2/A,WKT4,WKT4/A
26	16024-ZE1-811	SCREW SET, DRAIN	1	-	-	-----	ED4/A,ED5/A,HAQ,HA2,HA2/A,HHQ4/A,HX/A,HXQ4/A,LH/A,LHE4/A,LSX/A LX/A,LXF,LXQ4/A,LX2,LX2/A,PA2,PA2/A,PMT2,PMT2/A,PX/A,QAQ2,QAQ2/A QAG,QAQ/A,QAG2,QAQ2/A,QAQ,QA2,QA2/A,QH/A,QHB2,QHP1/A,QHQ4/A,QKA2 QMH/A,QW24,QX/A,QXB7,QXB7/A,QXC/A,QXC9,QXC9/A,QXE/A,QXE4/A,QXQ4/A QXU/A,RA2,RA2/A,RHQ4/A,RSC2,RX/A,RXQ4/A,SMX2,SMX2/A,SNR/A,STP/A STQ/A,SX/A,SXE4/A,SXQ4/A,SXU/A,VA2,VA2/A,VH/A,VH12,VH12/A,VTA2 VTA2/A,VX/A,VXB/A,VXB7,VXB7/A,VXE/A,VXEB/A,VXQ4/A,VXQ7/VXQ7/A VXU/A,VXU1/A,WKD6,WKD6/A,WKT2,WKT2/A,WKT4,WKT4/A
		(CARBURETOR NO.)	1	-	-	-----	BE70A B QXC
		//	1	-	-	-----	BE70B B ED3,ED4,ED5,HHQ4,HX,HXQ4,LH,LHE,LHE4,LHZ,LSX,LX,LXQ4,PX,QAQ4,QH QHP1,QHQ4,QHZ,QMH,QX,QXE,QXE4,QXQ4,QXU,RHQ4,RX,RXQ4,SHE,SNR,STP STQ,SX,SXE4,SXQ4,SXU,VH,VMX,VX,VXB,VXE,VXEB,VXQ4,VXU,VXU1
27	16172-ZE3-W10	COLLAR, SETTING	1	-	-	-----	ED4/A,ED5/A,HAQ,HA2,HA2/A,HHQ4/A,HX/A,HXQ4/A,LH/A,LHE4/A,LSX/A LX/A,LXF,LXQ4/A,LX2,LX2/A,PA2,PA2/A,PMT2,PMT2/A,PX/A,QAQ2,QAQ2/A QAG,QAQ/A,QAG2,QAQ2/A,QAQ,QA2,QA2/A,QH/A,QHB2,QHP1/A,QHQ4/A,QMH/A QW24,QX/A,QXB7,QXB7/A,QXC/A,QXC9,QXC9/A,QXE/A,QXE4/A,QXQ4/A,QXU/A RA2,RA2/A,RHQ4/A,RSC2,RX/A,RXQ4/A,SMX2,SMX2/A,SNR/A,STP/A,STQ/A SX/A,SXE4/A,SXQ4/A,SXU/A,VA2,VA2/A,VH/A,VH12,VH12/A,VTA2,VTA2/A VX/A,VXB/A,VXB7,VXB7/A,VXE/A,VXEB/A,VXQ4/A,VXQ7/VXQ7/A,VXU/A VXU1/A,WKD6,WKD6/A,WKT2,WKT2/A,WKT4,WKT4/A
		(CARBURETOR NO.)	1	-	-	-----	BE70A B QXC
		//	1	-	-	-----	BE70B B ED3,ED4,ED5,HHQ4,HX,HXQ4,LH,LHE,LHE4,LHZ,LSX,LX,LXQ4,PX,QAQ4,QH QHP1,QHQ4,QHZ,QMH,QX,QXE,QXE4,QXQ4,QXU,RHQ4,RX,RXQ4,SHE,SNR,STP STQ,SX,SXE4,SXQ4,SXU,VH,VMX,VX,VXB,VXE,VXEB,VXQ4,VXU,VXU1



E-14-3

CARBURETOR(4)

K11

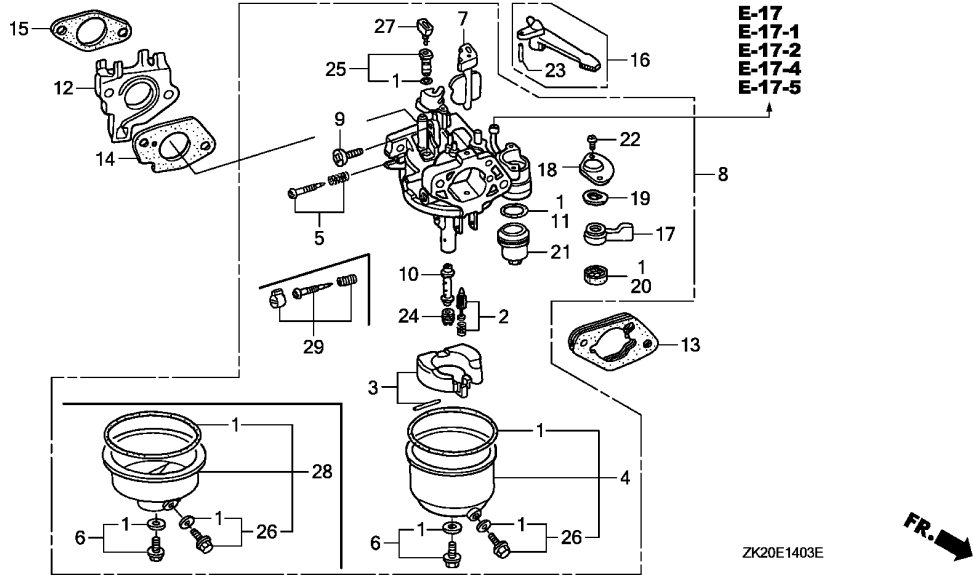

E-17
E-17-1
E-17-2
E-17-4
E-17-5

Ref. No.	Part No.	Description	Reqd. QTY			Serial No.	Parts catalogue code
			GX240K1				
			(1)	(2)	(3)		
28	16015-ZE8-005	CHAMBER SET, FLOAT	1	(1)	-	ED4/A,ED5/A,ES1/A,ES2,HA2/A,HHQ4/A,HX/A,HXQ4/A,LH/A,LHE4/A,LHZ LJ/A,LJG/A,LJG1,LKS/A,LP/A,LSS4,LSS5,LSS5/A,LSX,LSX/A,LT,LT/A LX/A,LXF,LXQ4/A,LX2/A,L1/A,PA2/A,PMT2/A,PX/A,QAE2/A,QAG,QAG/A QAG2/A,QA2/A,QE/A,QH/A,QHB2,QHP1,QHP1/A,QHQ4/A,QHZ,QKA2,QMH,QMH/A QP/A,QT/A,QW24,QX/A,QXB7,QXB7/A,QXC/A,QXC9/A,QXE/A,QXE4/A,QXQ4/A QXU,QXU/A,Q1/A,RA2/A,RHQ4/A,RJ/A,RSS1,RSS1/A,RX/A,RXQ4/A,R1/A SE/A,SHW,SHW/A,SJ/A,SJC1,SJC1/A,SJC5,SJC5/A,SJG/A,SMS/A,SMX2/A SNR/A,STP/A,STQ/A,SX/A,SXE4/A,SXQ4/A,SXU,SXU/A,S1/A,VA2/A,VH/A VH12/A,VMX,VTA2,VTA2/A,VX/A,VXB/A,VXB7,VXB7/A,VXE/A,VXEB/A,VXQ4/A VXQ7,VXQ7/A,VXU/A,VXU1,VXU1/A,WJ/A,WKD6,WKD6/A,WKT2/A,WKT4/A W1/A	
		(CARBURETOR NO.)	1	(1)	-	BE15G B	ED3,ED4,ED5,EN,ES,ES1,ET,ETS,ETX,HA,HH,HHQ4,HTX,HX,HXQ4,LH,LHE LHE4,LJ,LJG,LK,LKS,LM9,LNJ,LNZ,LP,LW,LX,LXQ4,LXZ,L1,PA,PAE,PX,P1 QA,QAE,QAQ4,QE,QH,QHE,QHQ4,QP,QT,QX,QXB,QXE,QXEB,QXE4,QXQ4,Q1,RA RH,RHE,RHE4,RHQ4,RJ,RX,RXQ4,R1,SE,SH,SHE,SHEZ,SJ,SJC,SJG,SJP,SK SMS,SNE1,SNR,STP,STQ,SW,SWE,SX,SXB,SXE,SXEB,SXE4,SXQ4,S1,VA,VAH1 VH,VNG,VTA,VX,VXB,VXE,VXEB,VXQ4,VXU,V1,WH,WJ,W1
		///	1	-	-	BE16D B	QHC,QXC
		///	1	-	-	BE70A B	HAQ,QAQ,QXC9
		///	1	-	-	BE70B B	HA2,LX2,PA2,PMT2,QAE2,QAG2,QA2,RA2,RSC2,SMX2,VA2,VH12,WKT2

E-14-3

CARBURETOR(4)

K12

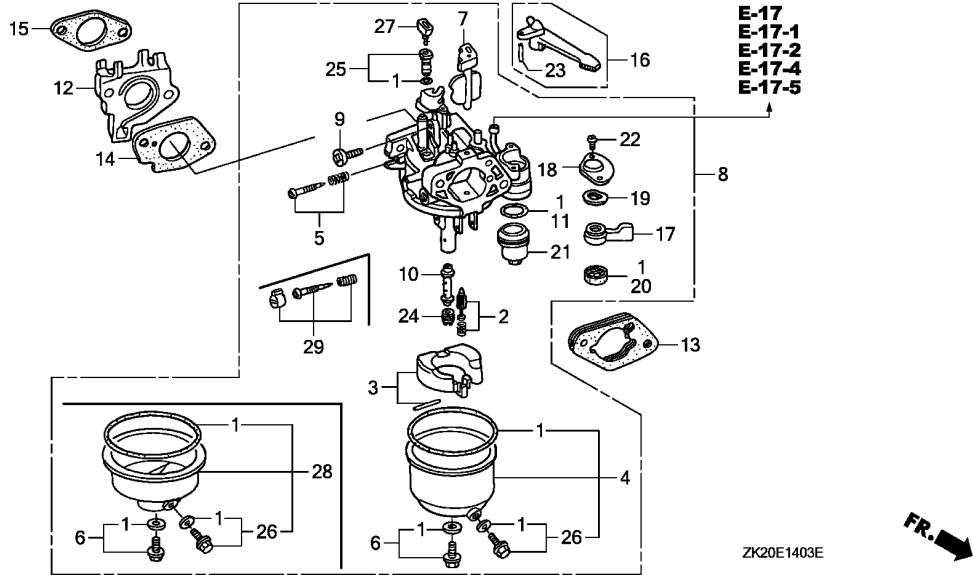

Ref. No.	Part No.	Description	Reqd. QTY			Serial No.	Parts catalogue code
			(1)	(2)	(3)		
29	16016-ZH7-W01	SCREW SET, PILOT (CARBURETOR NO.)	1	(1)	-	BE15G C	ES1/A, LJ/A, LJG/A, LKS/A, LP/A, LSS5/A, LT/A, L1/A, QE/A, QP/A, QT/A, Q1/A, RJ/A, RSS1/A, R1/A, SE/A, SHW/A, SJ/A, SJC1/A, SJC5/A, SJG/A, SMS/A, S1/A, WJ/A, W1/A
		(CARBURETOR NO.)	1	-	-		ED4/A, ED5/A, ES2, HA2, HA2/A, HHQ4/A, HX/A, HXQ4/A, LH/A, LHE4/A, LSX/A, LX/A, LXF, LXQ4/A, LX2, LX2/A, PA2, PA2/A, PMT2, PMT2/A, PX/A, QAE2, QAE2/A, QAG, QAG/A, QAG2, QAG2/A, QA2, QA2/A, QH/A, QHB2, QHP1/A, QHQ4/A, QKA2, QMH/A, QW24, QX/A, QXB7, QXB7/A, QXE/A, QXE4/A, QXQ4/A, QXU/A, RA2, RA2/A, RHQ4/A, RSC2, RX/A, RXQ4/A, SMX2, SMX2/A, SNR/A, STP/A, STQ/A, SX/A, SXE4/A, SXQ4/A, SXU/A, VA2, VA2/A, VH/A, VH12, VH12/A, VTA2, VTA2/A, VX/A, VXB/A, VXB7, VXB7/A, VXE/A, VXEB/A, VXQ4/A, VXQ7, VXQ7/A, VXU/A, VXU1/A, WKD6, WKD6/A, WKT2, WKT2/A, WKT4, WKT4/A
		(CARBURETOR NO.)	1	-	-	BE70B B	ED3, ED4, ED5, HHQ4, HX, HXQ4, LH, LHE, LHE4, LHZ, LSX, LX, LXQ4, PX, QAQ4, QH, QHP1, QHQ4, QHZ, QMH, QX, QXE, QXE4, QXQ4, QXU, RHQ4, RX, RXQ4, SHE, SNR, STP, STQ, SX, SXE4, SXQ4, SXU, VH, VMX, VX, VXB, VXE, VXEB, VXQ4, VXU, VXU1
	16016-ZH8-W01	SCREW SET (CARBURETOR NO.)	1	-	-	BE70A B	HAQ, QAQ, QXC/A, QXC9, QXC9/A, QXC

2

E-14-4

CARBURETOR(5)

K13

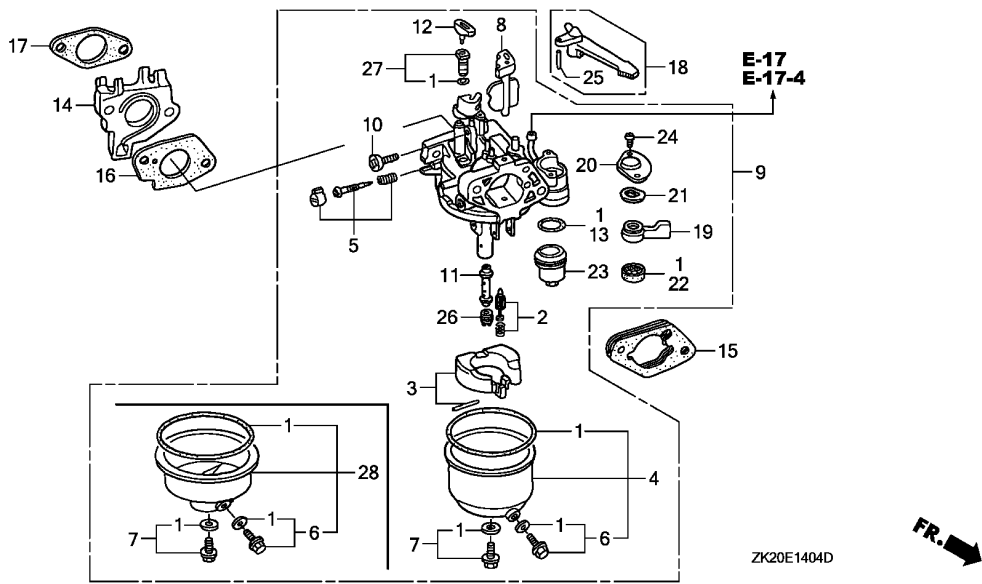

Ref. No.	L.O.N.	(Relative ref. Number) Description	F.R.T.
1	3111B1	GASKET SET, CARBURETOR (3)	0.3
2	3111E1	VALVE SET, FLOAT AND/OR FLOAT SET (28)	0.3
4	3111A3	CHAMBER SET, FLOAT AND/OR GASKET, FLOAT CHAMBER	0.2
5	3111D7	SCREW SET, PILOT	0.2
9	3111F3	CARBURETOR (23)	0.2
13	3101L6	PACKING, FUEL STRAINER CUP (17)	0.2
14	3111C0	INSULATOR, CARBURETOR AND/OR PACKING, INSULATOR	0.2
15	3111D9	SPACER, CARBURETOR	0.2
16	3111C8	PACKING, CARBURETOR	0.2
18	8101F9	LEVER, CARBURETOR CHOKE (19,20,21)	0.2
22	3101C5	PACKING, FUEL COCK	0.2
26	3111C3	JET, MAIN	0.3

2

Ref. No.	Part No.	Description	Reqd. QTY			Serial No.	Parts catalogue code
			(1)	(2)	(3)		
1	16010-ZE2-812	GASKET SET (INCLUDE 16173-001-004)	1	-	-	LJS,LJS/A,QAB2,QAB2/A,QAR2,QAR2/A,QC12,QC12/A,QMX2,QTC2,QTC2/A RTB2,RTB2/A,VDG2,VDG2/A,VWC2,VWC2/A	
2	16011-ZA0-931	VALVE SET, FLOAT	1	-	-	LJS,LJS/A,QAB2,QAB2/A,QAR2,QAR2/A,QC12,QC12/A,QMX2,QTC2,QTC2/A RTB2,RTB2/A,VDG2,VDG2/A,VWC2,VWC2/A	
3	16013-ZA0-931	FLOAT SET	1	-	-	LJS,LJS/A,QAB2,QAB2/A,QAR2,QAR2/A,QC12,QC12/A,QMX2,QTC2,QTC2/A RTB2,RTB2/A,VDG2,VDG2/A,VWC2,VWC2/A	
4	16015-ZE2-005	CHAMBER SET, FLOAT (CARBURETOR NO.)	1	-	-	BE70B A QAR2,RTB2,VWC2	
5	16016-ZH7-W01	SCREW SET, PILOT	1	-	-	LJS,LJS/A,QAB2,QAB2/A,QAR2,QAR2/A,QC12,QC12/A,QMX2,QTC2,QTC2/A RTB2,RTB2/A,VDG2,VDG2/A,VWC2,VWC2/A	
6	16024-ZE1-811	SCREW SET, DRAIN	1	-	-	LJS,LJS/A,QAB2,QAB2/A,QAR2,QAR2/A,QC12,QC12/A,QMX2,QTC2,QTC2/A RTB2,RTB2/A,VDG2,VDG2/A,VWC2,VWC2/A	
7	16028-ZE0-005	SCREW SET	1	-	-	LJS,LJS/A,QAB2,QAB2/A,QAR2,QAR2/A,QC12,QC12/A,QMX2,QTC2,QTC2/A RTB2,RTB2/A,VDG2,VDG2/A,VWC2,VWC2/A	
8	16044-ZE2-005	CHOKE SET	1	-	-	LJS,LJS/A,QAB2,QAB2/A,QAR2,QAR2/A,QC12,QC12/A,QMX2,QTC2,QTC2/A RTB2,RTB2/A,VDG2,VDG2/A,VWC2,VWC2/A	
9	16100-ZE2-W70 16100-ZE2-W71	CARBURETOR ASSY. (BE70B A) CARBURETOR ASSY. (BE70B B/C)	1 1	- -	- -	3453330 QAR2,RTB2,VWC2 LJS,LJS/A,QAB2,QAB2/A,QAR2,QAR2/A,QC12,QC12/A,QMX2,QTC2,QTC2/A,RTB2/A VDG2,VDG2/A,VWC2/A	
10	16124-ZE0-005	SCREW, THROTTLE STOP	1	-	-	3453331 QAR2,RTB2,VWC2 LJS,LJS/A,QAB2,QAB2/A,QAR2,QAR2/A,QC12,QC12/A,QMX2,QTC2,QTC2/A RTB2,RTB2/A,VDG2,VDG2/A,VWC2,VWC2/A	
11	16166-ZE2-W70	NOZZLE, MAIN	1	-	-	LJS,LJS/A,QAB2,QAB2/A,QAR2,QAR2/A,QC12,QC12/A,QMX2,QTC2,QTC2/A RTB2,RTB2/A,VDG2,VDG2/A,VWC2,VWC2/A	
12	16172-ZE3-W10	COLLAR, SETTING	1	-	-	LJS,LJS/A,QAB2,QAB2/A,QAR2,QAR2/A,QC12,QC12/A,QMX2,QTC2,QTC2/A RTB2,RTB2/A,VDG2,VDG2/A,VWC2,VWC2/A	

Ref. No.	Part No.	Description	Reqd. QTY			Serial No.	Parts catalogue code
			(1)	(2)	(3)		
13	16173-001-004	PACKING, FUEL STRAINER CUP ..	1	-	-	-----	LJS,LJS/A,QAB2,QAB2/A,QAR2,QAR2/A,QC12,QC12/A,QMX2,QTC2,QTC2/A
14	16211-ZE2-000	INSULATOR, CARBURETOR	1	-	-	-----	RTB2,RTB2/A,VDG2,VDG2/A,VWC2,VWC2/A
15	16220-ZA0-702	SPACER COMP., CARBURETOR	1	-	-	-----	LJS,LJS/A,QAB2,QAB2/A,QAR2,QAR2/A,QC12,QC12/A,QMX2,QTC2,QTC2/A
16	16221-ZA0-800	PACKING, CARBURETOR	1	-	-	-----	RTB2,RTB2/A,VDG2,VDG2/A,VWC2,VWC2/A
17	16223-ZA0-800	PACKING, INSULATOR	1	-	-	-----	LJS,LJS/A,QAB2,QAB2/A,QAR2,QAR2/A,QC12,QC12/A,QMX2,QTC2,QTC2/A
18	16610-ZE1-000	LEVER COMP., CHOKE (STD.) ...	1	-	-	-----	RTB2,RTB2/A,VDG2,VDG2/A,VWC2,VWC2/A
19	16953-ZE1-811	LEVER, COCK	1	-	-	-----	LJS,LJS/A,QAB2,QAB2/A,QAR2,QAR2/A,QC12,QC12/A,QMX2,QTC2,QTC2/A
	16953-ZE1-812	(CARBURETOR NO.)	1	-	-	-----	RTB2,RTB2/A,VDG2,VDG2/A,VWC2,VWC2/A
		(CARBURETOR NO.)	1	-	-	-----	BE70B A QAR2,RTB2,VWC2
20	16954-ZE1-811	PLATE, LEVER SETTING	1	-	-	-----	LJS,LJS/A,QAB2,QAB2/A,QAR2/A,QC12,QC12/A,QMX2,QTC2,QTC2/A,RTB2/A
	16954-ZE1-812	(CARBURETOR NO.)	1	-	-	-----	VDG2,VDG2/A,VWC2/A
		(CARBURETOR NO.)	1	-	-	-----	BE70B A QAR2,RTB2,VWC2
		(CARBURETOR NO.)	1	-	-	-----	LJS,LJS/A,QAB2,QAB2/A,QAR2/A,QC12,QC12/A,QMX2,QTC2,QTC2/A,RTB2/A
		(CARBURETOR NO.)	1	-	-	-----	VDG2,VDG2/A,VWC2/A
		(CARBURETOR NO.)	1	-	-	-----	BE70B B QAR2,RTB2,VWC2
21	16956-ZE1-811	SPRING, COCK LEVER	1	-	-	-----	LJS,LJS/A,QAB2,QAB2/A,QAR2,QAR2/A,QC12,QC12/A,QMX2,QTC2,QTC2/A
22	16957-ZE1-812	PACKING, FUEL COCK	1	-	-	-----	RTB2,RTB2/A,VDG2,VDG2/A,VWC2,VWC2/A
23	16967-ZE0-811	CUP, FUEL STRAINER	1	-	-	-----	LJS,LJS/A,QAB2,QAB2/A,QAR2,QAR2/A,QC12,QC12/A,QMX2,QTC2,QTC2/A
24	93500-03008-1G	SCREW, PAN, 3X8	2	-	-	-----	RTB2,RTB2/A,VDG2,VDG2/A,VWC2,VWC2/A
	93500-03006-1H	(CARBURETOR NO.)	2	-	-	-----	BE70B A QAR2,RTB2,VWC2
		SCREW, PAN, 3X6	2	-	-	-----	LJS,LJS/A,QAB2,QAB2/A,QAR2/A,QC12,QC12/A,QMX2,QTC2,QTC2/A,RTB2/A
		(CARBURETOR NO.)	2	-	-	-----	VDG2,VDG2/A,VWC2/A
25	94305-20122	PIN, SPRING, 2X12	1	-	-	-----	BE70B B QAR2,RTB2,VWC2
			1	-	-	-----	LJS,LJS/A,QAB2,QAB2/A,QAR2,QAR2/A,QC12,QC12/A,QMX2,QTC2,QTC2/A
			1	-	-	-----	RTB2,RTB2/A,VDG2,VDG2/A,VWC2,VWC2/A
26	99101-ZH7-0820	JET, MAIN, #82	1	-	-	-----	BE70B A QAR2,RTB2,VWC2
	99101-ZH7-0850	(CARBURETOR NO.)	1	-	-	-----	BE70B A QAR2,RTB2,VWC2
	99101-ZH7-0880	JET, MAIN, #85	1	-	-	-----	BE70B A QAR2,RTB2,VWC2
	99101-ZH8-0820	(CARBURETOR NO.)	1	-	-	-----	BE70B A QAR2,RTB2,VWC2
		JET, MAIN, #82	(1)	-	-	-----	LJS,LJS/A,QAB2,QAB2/A,QAR2/A,QC12,QC12/A,QMX2,QTC2,QTC2/A,RTB2/A
		(CARBURETOR NO.)	(1)	-	-	-----	VDG2,VDG2/A,VWC2/A
		(CARBURETOR NO.)	(1)	-	-	-----	BE70B B QAR2,RTB2,VWC2
	99101-ZH8-0850	JET, MAIN, #85	(1)	-	-	-----	LJS,LJS/A,QAB2,QAB2/A,QAR2/A,QC12,QC12/A,QMX2,QTC2,QTC2/A,RTB2/A
		(CARBURETOR NO.)	(1)	-	-	-----	VDG2,VDG2/A,VWC2/A
		(CARBURETOR NO.)	(1)	-	-	-----	BE70B B QAR2,RTB2,VWC2
	99101-ZH8-0880	JET, MAIN, #88	1	-	-	-----	LJS,LJS/A,QAB2,QAB2/A,QAR2/A,QC12,QC12/A,QMX2,QTC2,QTC2/A,RTB2/A
		(CARBURETOR NO.)	1	-	-	-----	VDG2,VDG2/A,VWC2/A
		(CARBURETOR NO.)	1	-	-	-----	BE70B B QAR2,RTB2,VWC2
27	99204-ZE0-0400	JET SET, PILOT, #40	1	-	-	-----	BE70B B LJS,LJS/A,QAB2,QAB2/A,QAR2/A,QC12,QC12/A,QMX2,QTC2,QTC2/A,RTB2/A
		(CARBURETOR NO.)	1	-	-	-----	VDG2,VDG2/A,VWC2/A
		..	1	-	-	-----	BE70B B QAR2,RTB2,VWC2

E-14-4

CARBURETOR(5)

K15

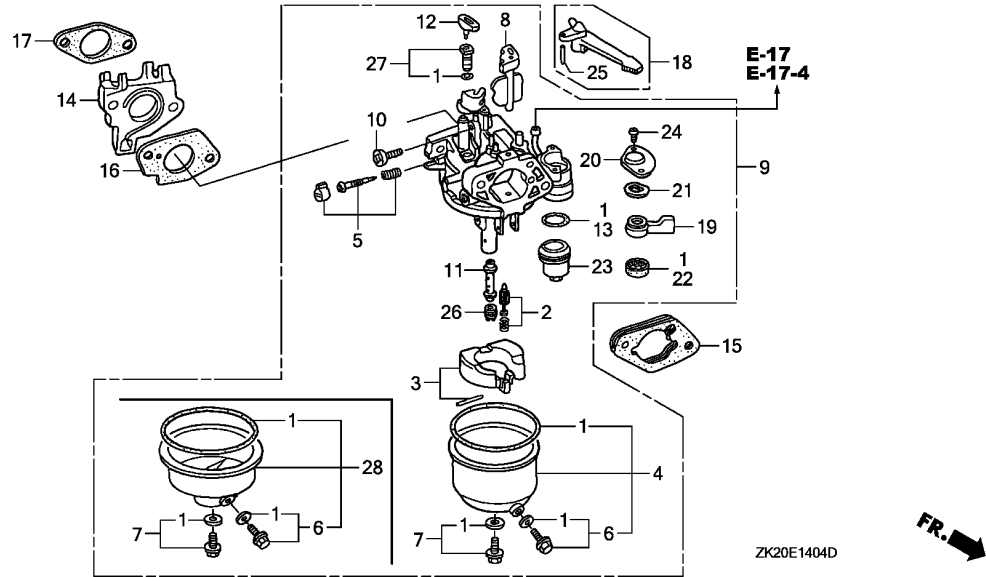

Ref. No.	Part No.	Description	Reqd. QTY			Serial No.	Parts catalogue code
			GX240K1				
			(1)	(2)	(3)		
27)	99204-ZE2-0400	JET SET, PILOT, #40	1	-	-	BE70B A	QAR2,RTB2,VWC2
	99204-ZA0-0400	(CARBURETOR NO.)	1	-	-	BE70B C	LJS,LJS/A,QAB2,QAB2/A,QAR2,QAR2/A,QC12,QC12/A,QMX2,QTC2,QTC2/A RTB2,RTB2/A,VDG2,VDG2/A,VWC2,VWC2/A
28	16015-ZE8-005	CHAMBER SET, FLOAT	1	-	-		LJS,LJS/A,QAB2,QAB2/A,QAR2/A,QC12,QC12/A,QMX2,QTC2,QTC2/A,RTB2/A VDG2,VDG2/A,VWC2/A
		(CARBURETOR NO.)	1	-	-	BE70B B	QAR2,RTB2,VWC2

E-14-5

CARBURETOR(6)

K16

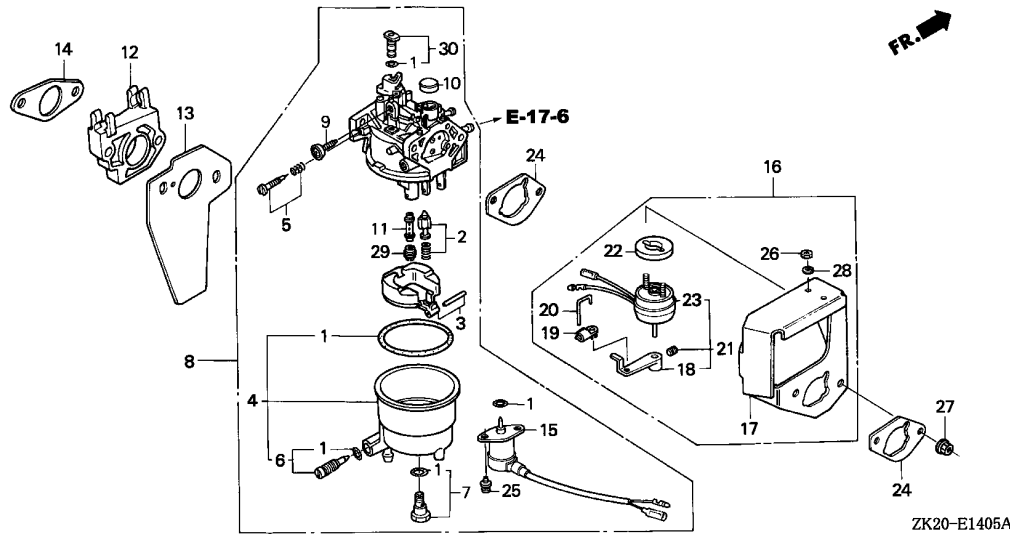

Ref. No.	L.O.N.	(Relative ref. Number) Description	F.R.T.
1	3111G1	GASKET SET, CARBURETOR(A)	0.4
2	3111G6	VALVE SET, FLOAT AND/OR FLOAT SET(A)	0.4
4	3111M2	CHAMBER SET, FLOAT AND/OR GASKET, FLOAT CHAMBER(A)	0.3
5	3111D7	SCREW SET, PILOT	0.2
8	3111G7	CARBURETOR(A)	0.3
12	3111G2	INSULATOR, CARBURETOR AND/OR PACKING, INSULATOR(A)	0.3
13	3111G5	PACKING, CARBURETOR(A)	0.3
15	6211C0	VALVE, CARBURETOR SOLENOID ...	0.3
16	8101R2	STAY, ROTARY CHOKE SOLENOID ..	0.3
18	8101Z6	LEVER, CARBURETOR CHOKE(A) ...	0.3
23	8101Z7	SOLENOID, ROTARY CHOKE(A)	0.3
24	3121H2	PACKING, AIR CLEANER(A)	0.3
29	3111G4	JET, MAIN(A)	0.4

.NOTE: Same time for two units

Ref. No.	Part No.	Description	Reqd. QTY			Serial No.	Parts catalogue code
			(1)	(2)	(3)		
1	16010-ZE3-701	GASKET SET	1	-	-	EDS5	
2	16011-ZA0-931	VALVE SET, FLOAT	1	-	-	EDS5	
3	16013-ZA0-931	FLOAT SET	1	-	-	EDS5	
4	16015-ZA0-931	CHAMBER SET, FLOAT	1	-	-	EDS5	
5	16016-ZE0-005	SCREW SET, PILOT	1	-	-	EDS5	
6	16024-124-761	SCREW SET, DRAIN	1	-	-	EDS5	
7	16028-ZA0-931	SCREW SET	1	-	-	EDS5	
8	16100-ZE2-E10	CARBURETOR ASSY. (BE22C A) ..	1	-	-	3456445 EDS5	
	16100-ZE2-E11	CARBURETOR ASSY. (BE22C B) ..	1	-	-	3456446 EDS5	
9	16124-ZE0-005	SCREW, THROTTLE STOP	1	-	-	EDS5	
10	16148-141-881	CAP, CHOKE DUST	1	-	-	EDS5	
11	16166-ZE2-015	NOZZLE, MAIN	1	-	-	EDS5	
12	16211-ZB7-000	INSULATOR, CARBURETOR	1	-	-	EDS5	
13	16221-ZB7-800	PACKING, CARBURETOR	1	-	-	EDS5	
14	16223-ZA0-800	PACKING, INSULATOR	1	-	-	EDS5	
15	16230-ZE3-701	VALVE ASSY., SOLENOID	1	-	-	EDS5	
16	16260-ZB7-000	STAY ASSY., SOLENOID	1	-	-	EDS5	
17	16261-ZB7-000	STAY COMP., CHOKE SOLENOID ..	1	-	-	EDS5	
18	16262-ZB7-000	LEVER, CHOKE SOLENOID	1	-	-	EDS5	
19	16263-ZA0-000	JOINT, ROD	1	-	-	EDS5	
20	16264-ZB7-000	ROD, CHOKE SOLENOID	1	-	-	EDS5	
21	16265-ZB7-000	SOLENOID ASSY., CHOKE	1	-	-	EDS5	
22	16266-ZB7-000	SPACER, CHOKE SOLENOID	1	-	-	EDS5	
23	16267-ZB7-003	SOLENOID, ROTARY CHOKE	1	-	-	EDS5	
24	16269-ZA0-800	PACKING, AIR CLEANER	2	-	-	EDS5	



E-14-5

CARBURETOR(6)

L 1

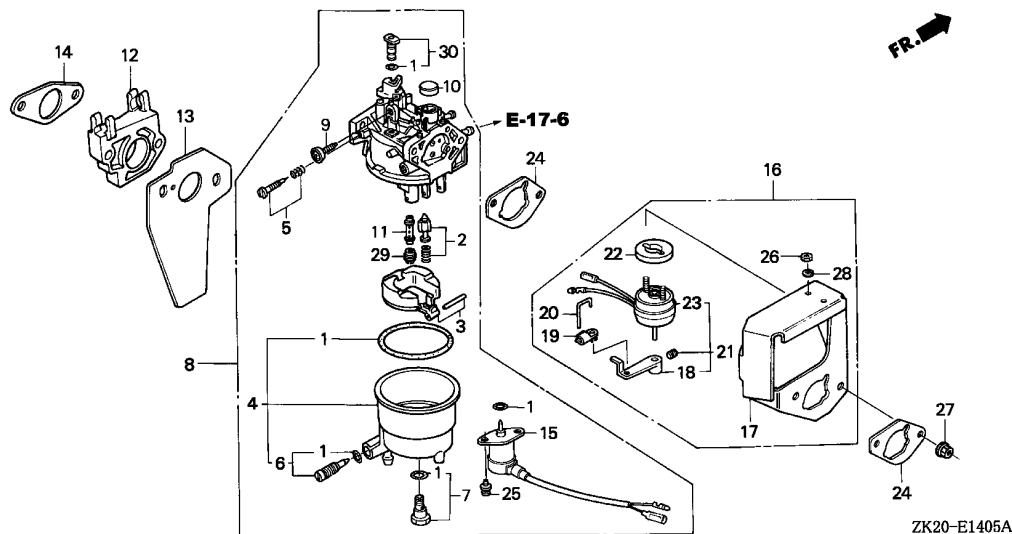

2

Ref. No.	Part No.	Description	Reqd. QTY			Serial No.	Parts catalogue code
			(1)	(2)	(3)		
25	93892-05012-18	SCREW-WASHER, 5X12	2	-	-	-----	EDS5
26	94001-03000-0S	NUT, HEX., 3MM	2	-	-	-----	EDS5
27	94050-06000	NUT, FLANGE, 6MM	2	-	-	-----	EDS5
28	94111-03800	WASHER, SPRING, 3MM	2	-	-	-----	EDS5
29	99101-ZF5-0780	JET, MAIN, #78	(1)	-	-	-----	BE22C A EDS5
	99101-ZF5-0800	JET, MAIN, #80 (CARBURETOR NO.)	(1)	-	-	-----	BE22C A EDS5
	99101-ZF5-0820	JET, MAIN, #82 (CARBURETOR NO.)	1	-	-	-----	BE22C A EDS5
	99101-ZH8-0780	JET, MAIN, #78	(1)	-	-	BE22C B -----	EDS5
	99101-ZH8-0800	JET, MAIN, #80 (CARBURETOR NO.)	(1)	-	-	BE22C B -----	EDS5
	99101-ZH8-0820	JET, MAIN, #82 (CARBURETOR NO.)	1	-	-	BE22C B -----	EDS5
30	99204-ZE0-0400	JET SET, PILOT, #40	1	-	-	-----	EDS5

E-14-6

CARBURETOR(7)

L 2

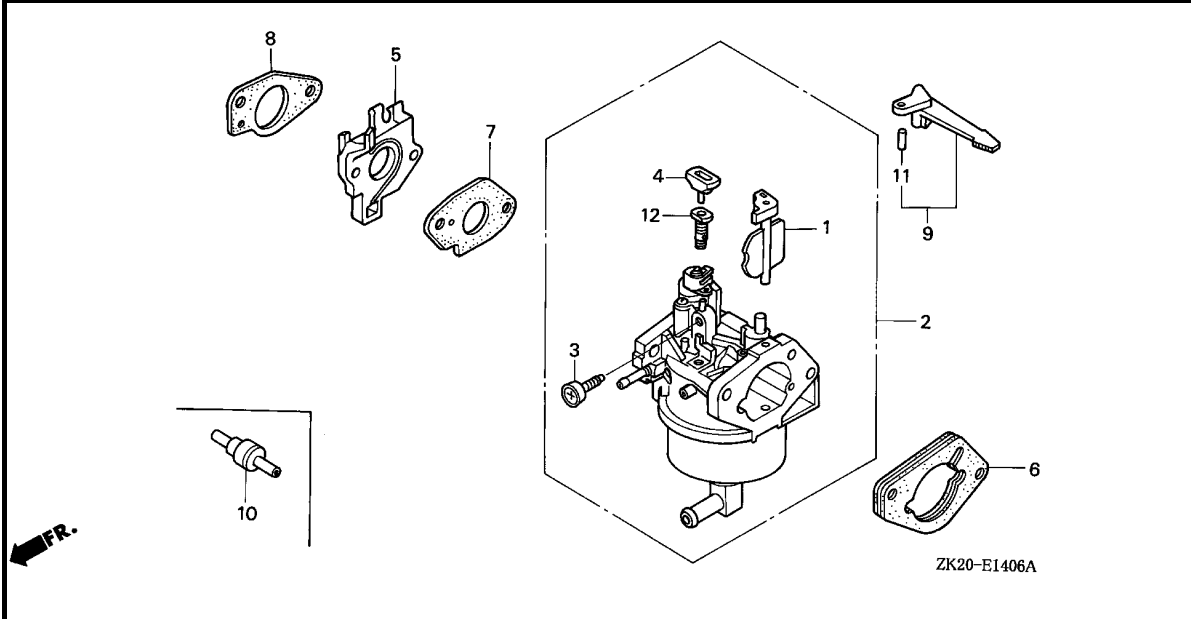

Ref. No.	L.O.N.	(Relative ref. Number) Description	F.R.T.
2	3111F3	CARBURETOR	0.2
5		(8)	
	3111C0	INSULATOR, CARBURETOR AND/OR PACKING, INSULATOR	0.2
6	3111D9	SPACER, CARBURETOR	0.2
7	3111C8	PACKING, CARBURETOR	0.2
9	8101F9	LEVER, CARBURETOR CHOKE	0.2
10	311175	VALVE, DASHPOT CHECK	0.1

Ref. No.	Part No.	Description	Reqd. QTY			Serial No.	Parts catalogue code
			GX240K1				
			(1)	(2)	(3)		
1	16044-ZE2-W81	CHOKE SET	-	-	1		
2	16100-ZE2-W81	CARBURETOR ASSY. (BEL2A A) ..	-	-	1		
3	16124-ZE0-005	SCREW, THROTTLE STOP	-	-	1		
4	16172-ZE3-W10	COLLAR, SETTING	-	-	1		
5	16211-ZE2-000	INSULATOR, CARBURETOR	-	-	1		
6	16220-ZA0-702	SPACER COMP., CARBURETOR	-	-	1		
7	16221-ZA0-800	PACKING, CARBURETOR	-	-	1		
8	16223-ZA0-800	PACKING, INSULATOR	-	-	1		
9	16610-ZE1-000	LEVER COMP., CHOKE (STD.) ...	-	-	1		
10	36135-PH3-004	VALVE, DASHPOT CHECK	-	-	(1)		
11	94305-20122	PIN, SPRING, 2X12	-	-	1		
12	99104-ZE0-0450	JET, PILOT, #45	-	-	1		

2

E-15

AIR CLEANER(1)

L 3

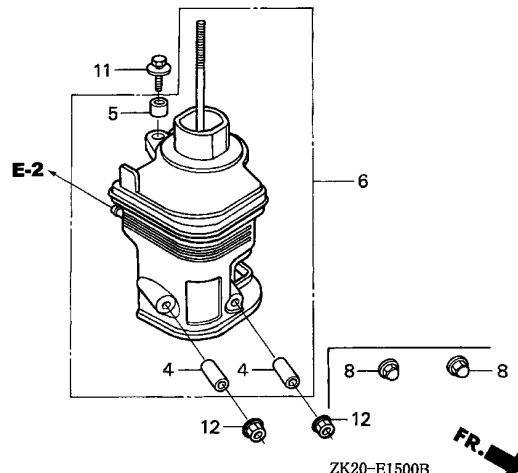
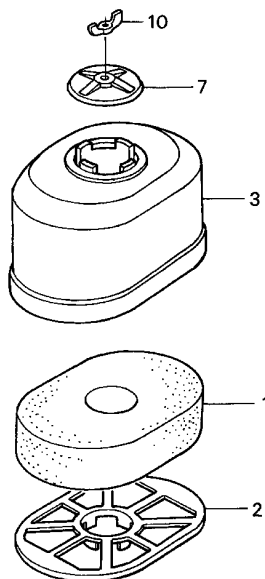

Ref. No.	L.O.N.	(Relative ref. Number) Description	F.R.T.
1		(2)	
3121B8		ELEMENT, AIR CLEANER	0.1
6		3121B4 ELBOW, AIR CLEANER	0.1

Ref. No.	Part No.	Description	Reqd. QTY			Serial No.	Parts catalogue code
			(1)	(2)	(3)		
1	17211-ZE2-000	ELEMENT, AIR CLEANER (SEMI DRY)	1	-	-	-----	EN,ET,ETS,ETX,HTX,LD,LDB1,LDB3,LJ,LJ/A,LJG,LJG/A,LJG1,LK,LNJ,LNZ LSS5,LSS5/A,QD,QD/A,QDA,RD,RD/A,RJ,RJ/A,RSS1,RSS1/A,SD,SD/A,SDB1 SDB3,SDB3/A,SHW,SHW/A,SJ,SJ/A,SJC,SJC1,SJC1/A,SJC5,SJC5/A,SJG SJG/A,SJP,SK,WJ,WJ/A,WKD6,WKD6/A,WKT2,WKT2/A,WKT4,WKT4/A,WMK
2	17212-ZE2-000	GRID, AIR CLEANER	-	(1)	-	-----	EN,ET,ETS,ETX,HTX,LD,LDB1,LDB3,LJ,LJ/A,LJG,LJG/A,LJG1,LK,LNJ,LNZ LSS5,LSS5/A,QD,QD/A,QDA,RD,RD/A,RJ,RJ/A,RSS1,RSS1/A,SD,SD/A,SDB1 SDB3,SDB3/A,SHW,SHW/A,SJ,SJ/A,SJC,SJC1,SJC1/A,SJC5,SJC5/A,SJG SJG/A,SJP,SK,WJ,WJ/A,WKD6,WKD6/A,WKT2,WKT2/A,WKT4,WKT4/A,WMK
3	17231-ZE2-000	COVER, AIR CLEANER (SEMI DRY)	-	(1)	-	-----	EN,ET,ETS,ETX,HTX,LD,LDB1,LDB3,LJ,LJ/A,LJG,LJG/A,LJG1,LK,LNJ,LNZ LSS5,LSS5/A,QD,QD/A,QDA,RD,RD/A,RJ,RJ/A,RSS1,RSS1/A,SD,SD/A,SDB1 SDB3,SDB3/A,SHW,SHW/A,SJ,SJ/A,SJC,SJC1,SJC1/A,SJC5,SJC5/A,SJG SJG/A,SJP,SK,WJ,WJ/A,WKD6,WKD6/A,WKT2,WKT2/A,WKT4,WKT4/A,WMK
4	17238-ZE2-310	COLLAR, AIR CLEANER	-	(1)	-	-----	EN,ET,ETS,ETX,HTX,LD,LDB1,LDB3,LJ,LJ/A,LJG,LJG/A,LJG1,LK,LNJ,LNZ LSS5,LSS5/A,QD,QD/A,QDA,RD,RD/A,RJ,RJ/A,RSS1,RSS1/A,SD,SD/A,SDB1 SDB3,SDB3/A,SHW,SHW/A,SJ,SJ/A,SJC,SJC1,SJC1/A,SJC5,SJC5/A,SJG SJG/A,SJP,SK,WJ,WJ/A,WKD6,WKD6/A,WKT2,WKT2/A,WKT4,WKT4/A,WMK
5	17239-ZE1-000	COLLAR B, AIR CLEANER	-	(2)	-	-----	EN,ET,ETS,ETX,HTX,LD,LDB1,LDB3,LJ,LJ/A,LJG,LJG/A,LJG1,LK,LNJ,LNZ LSS5,LSS5/A,QD,QD/A,QDA,RD,RD/A,RJ,RJ/A,RSS1,RSS1/A,SD,SD/A,SDB1 SDB3,SDB3/A,SHW,SHW/A,SJ,SJ/A,SJC,SJC1,SJC1/A,SJC5,SJC5/A,SJG SJG/A,SJP,SK,WJ,WJ/A,WKD6,WKD6/A,WKT2,WKT2/A,WKT4,WKT4/A,WMK
			-	(1)	-	-----	

Ref. No.	Part No.	Description	Reqd. QTY			Serial No.	Parts catalogue code
			(1)	(2)	(3)		
6	17410-ZE2-020	ELBOW COMP., AIR CLEANER	1	-	-		EN,ET,ETS,ETX,HTX,LD,LDB1,LDB3,LJ,LJ/A,LJG,LJG/A,LJG1,LK,LNJ,LNZ LSS5,LSS5/A,QD,QD/A,QDA,RD,RD/A,RJ,RJ/A,RSS1,RSS1/A,SD,SD/A,SDB1 SDB3,SDB3/A,SHW,SHW/A,SJ,SJ/A,SJC,SJC1,SJC1/A,SJC5,SJC5/A,SJG SJG/A,SJP,SK,WJ,WJ/A,WKD6,WKD6/A,WKT2,WKT2/A,WKT4,WKT4/A,WMK
7	17420-ZE2-000	CAP COMP., AIR CLEANER	1	(1)	-		EN,ET,ETS,ETX,HTX,LD,LDB1,LDB3,LJ,LJ/A,LJG,LJG/A,LJG1,LK,LNJ,LNZ LSS5,LSS5/A,QD,QD/A,QDA,RD,RD/A,RJ,RJ/A,RSS1,RSS1/A,SD,SD/A,SDB1 SDB3,SDB3/A,SHW,SHW/A,SJ,SJ/A,SJC,SJC1,SJC1/A,SJC5,SJC5/A,SJG SJG/A,SJP,SK,WJ,WJ/A,WKD6,WKD6/A,WKT2,WKT2/A,WKT4,WKT4/A,WMK
8	90201-415-000	NUT, CAP, 6MM	2	(1)	-	3165927	EN,ET,ETS,ETX,HTX,LD,LJ,LK,LNJ,L1,P1,QD,Q1,RD,RJ,R1,SD,SJ,SJP,SK S1,V1,WJ,W1
10	90325-044-000	NUT, TOOL BOX SETTING	2	-	-		QDA
			1	-	-		EN,ET,ETS,ETX,HTX,LD,LDB1,LDB3,LJ,LJ/A,LJG,LJG/A,LJG1,LK,LNJ,LNZ LSS5,LSS5/A,QD,QD/A,QDA,RD,RD/A,RJ,RJ/A,RSS1,RSS1/A,SD,SD/A,SDB1 SDB3,SDB3/A,SHW,SHW/A,SJ,SJ/A,SJC,SJC1,SJC1/A,SJC5,SJC5/A,SJG SJG/A,SJP,SK,WJ,WJ/A,WKD6,WKD6/A,WKT2,WKT2/A,WKT4,WKT4/A,WMK
11	93494-06020-08	BOLT-WASHER, 6X20	1	1	-		EN,ET,ETS,ETX,HTX,LD,LDB1,LDB3,LJ,LJG,LJG1,LK,LNJ,LNZ,LSS5,L1,P1 QD,QDA,Q1,RD,RJ,RSS1,R1,SD,SDB1,SDB3,SJ,SJC,SJC1,SJC5,SJG,SJP,SK S1,V1,WJ,WKD6,WKT2,WKT4,W1
	90009-ZE2-003	BOLT-WASHER, 6X22	1	1	-		LJ/A,LJG/A,LSS5/A,L1/A,QD/A,Q1/A,RD/A,RJ/A,RSS1/A,R1/A,SD/A SDB3/A,SHW,SHW/A,SJ/A,SJC1/A,SJC5/A,SJG/A,S1/A,WJ/A,WKD6/A,WKT2/A WKT4/A,WMK,W1/A
12	94050-06000	NUT, FLANGE, 6MM	2	2	-		LDB1,LDB3,LJ/A,LJG,LJG/A,LJG1,LNZ,LSS5,LSS5/A,L1/A,QD/A,Q1/A,RD/A RJ/A,RSS1,RSS1/A,R1/A,SD/A,SDB1,SDB3,SDB3/A,SHW,SHW/A,SJ/A,SJC SJC1,SJC1/A,SJC5,SJC5/A,SJG,SJG/A,S1/A,WJ/A,WKD6,WKD6/A,WKT2 WKT2/A,WKT4,WKT4/A,WMK,W1/A
			2	2	-	3165928	EN,ET,ETS,ETX,HTX,LD,LJ,LK,LNJ,L1,P1,QD,Q1,RD,RJ,R1,SD,SJ,SJP,SK S1,V1,WJ,W1



E-15-1

AIR CLEANER(2)

L 5

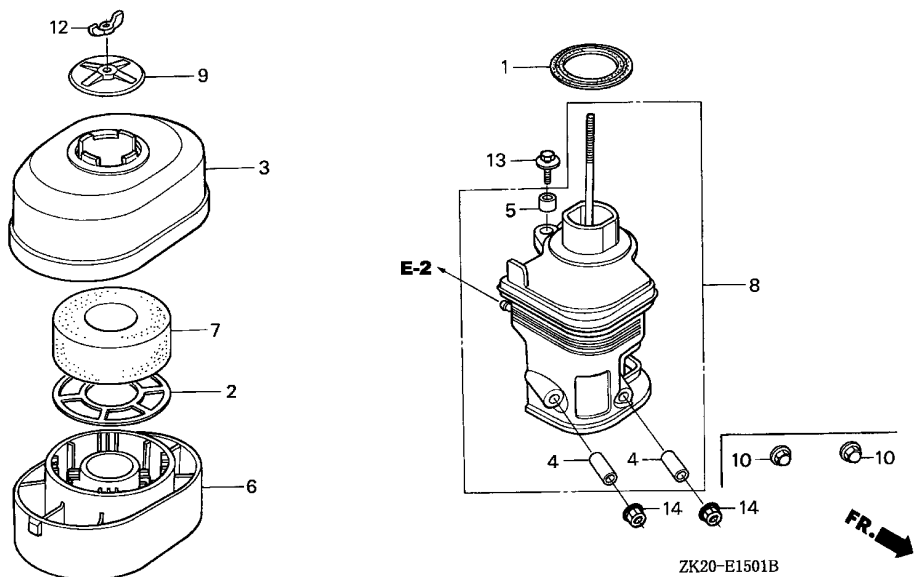

Ref. No.	L.O.N.	(Relative ref. Number) Description	F.R.T.
1	3121E1	PACKING, ELBOW	0.1
6	3121E5	PAN, AIR CLEANER OIL	0.1
7		(2)	
	3121B8	ELEMENT, AIR CLEANER	0.1
8	3121B4	ELBOW, AIR CLEANER	0.1

Ref. No.	Part No.	Description	Reqd. QTY			Serial No.	Parts catalogue code
			(1)	(2)	(3)		
			GX240K1				
1	16271-ZE2-000	PACKING, ELBOW	1	(1)	-	LM9,LP,LT,LW,L1,P1,QP,QT,Q1,R1,SW,SWE,S1,V1,W1	
	16271-ZE2-010	1	(1)	-	LP/A,LT/A,L1/A,QP/A,QT/A,Q1/A,R1/A,S1/A,W1/A	
2	17212-ZE2-810	GRID, AIR CLEANER (OIL BATH)	1	-	-	LM9,LP,LP/A,LT,LT/A,LW,QP,QP/A,QT,QT/A,SW,SWE	
			-	(1)	-		
3	17231-ZE2-810	COVER, AIR CLEANER (OIL BATH)	1	-	-	LM9,LP,LP/A,LT,LT/A,LW,QP,QP/A,QT,QT/A,SW,SWE	
			-	(1)	-		
4	17238-ZE2-310	COLLAR, AIR CLEANER	2	-	-	LM9,LP,LP/A,LT,LT/A,LW,QP,QP/A,QT,QT/A,SW,SWE	
			-	(2)	-		
5	17239-ZE1-000	COLLAR B, AIR CLEANER	1	-	-	LM9,LP,LP/A,LT,LT/A,LW,QP,QP/A,QT,QT/A,SW,SWE	
			-	(1)	-		
6	17402-ZE2-810	PAN, CLEANER OIL (OIL BATH)	1	-	-	LM9,LP,LP/A,LT,LT/A,LW,QP,QP/A,QT,QT/A,SW,SWE	
			-	(1)	-		
7	17403-ZE2-810	ELEMENT, AIR CLEANER (OIL BATH)	1	-	-	LM9,LP,LP/A,LT,LT/A,LW,QP,QP/A,QT,QT/A,SW,SWE	
			-	(1)	-		
8	17410-ZE2-020	ELBOW COMP., AIR CLEANER	1	-	-	LM9,LP,LP/A,LT,LT/A,LW,QP,QP/A,QT,QT/A,SW,SWE	
			-	(1)	-		
9	17420-ZE2-000	CAP COMP., AIR CLEANER	1	-	-	LM9,LP,LP/A,LT,LT/A,LW,QP,QP/A,QT,QT/A,SW,SWE	
			-	(1)	-		
10	90201-415-000	NUT, CAP, 6MM	2	2	-	3165927 LM9,LP,LW,L1,P1,QP,QT,Q1,R1,SW,SWE,S1,V1,W1	
12	90325-044-000	NUT, TOOL BOX SETTING	1	-	-	LM9,LP,LP/A,LT,LT/A,LW,QP,QP/A,QT,QT/A,SW,SWE	
			-	(1)	-		
13	93494-06020-08	BOLT-WASHER, 6X20	1	1	-	LM9,LP,LT,LW,L1,P1,QP,QT,Q1,R1,SW,SWE,S1,V1,W1	
	90009-ZE2-003	BOLT-WASHER, 6X22	1	1	-	LP/A,LT/A,L1/A,QP/A,QT/A,Q1/A,R1/A,S1/A,W1/A	
14	94050-06000	NUT, FLANGE, 6MM	2	2	-	LP/A,LT,LT/A,L1/A,QP/A,QT/A,Q1/A,R1/A,S1/A,W1/A	
			2	2	-	3165928 LM9,LP,LW,L1,P1,QP,QT,Q1,R1,SW,SWE,S1,V1,W1	

E-15-2

AIR CLEANER(3)

L 6

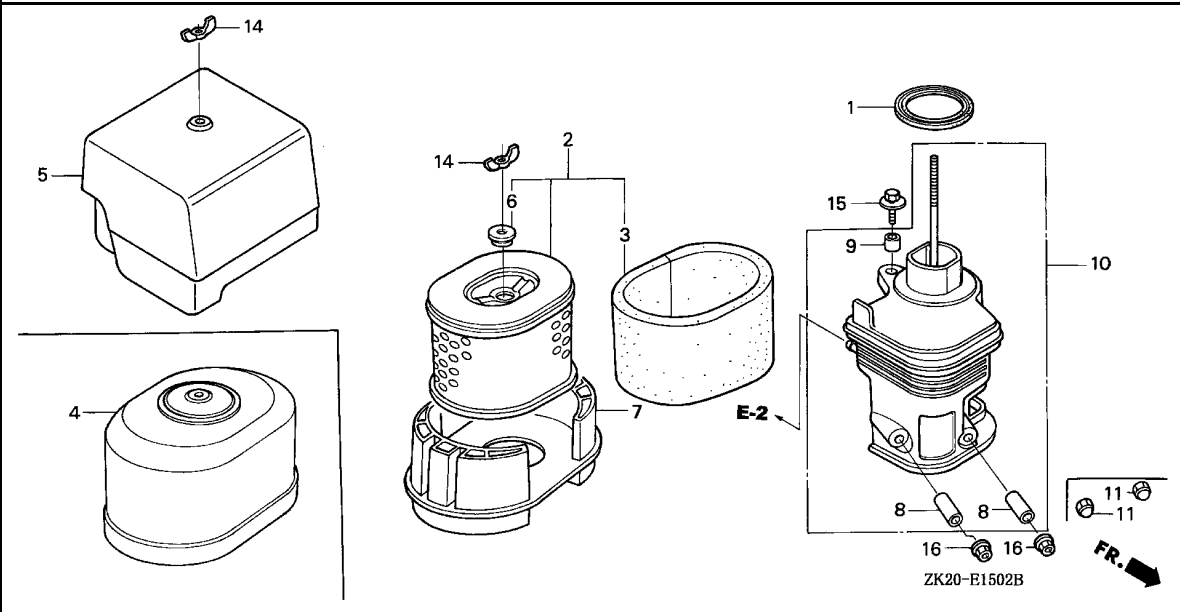

Ref. No.	L.O.N.	(Relative ref. Number) Description	F.R.T.
1	3121E1	PACKING, ELBOW	0.1
2	3121B8	ELEMENT, AIR CLEANER	0.1
3	3121C1	FILTER, OUTER	0.1
10	3121B4	ELBOW, AIR CLEANER	0.1

Ref. No.	Part No.	Description	Reqd. QTY			Serial No.	Parts catalogue code
			(1)	(2)	(3)		
1	16271-ZE2-000	PACKING, ELBOW	1	(1)	1	ED3,ED4,ED5,ES,ES1,HA,HAQ,HA2,HH,HHQ4,HX,HXQ4,LH,LHE,LHE4,LHZ,LJS,LSX,LX,LXQ4,LXZ,LX2,L1,PA,PAE,PA2,PMT2,PX,P1,QA,QAB2,QAE,QAE2,QAG,QAG/A,QAG2,QAQ,QAQ4,QAR2,QA2,QC12,QE,QH,QHE,QHP1,QHQ4,QHZ,QKA2,QMH,QMX2,QTC2,QX,QXE,QXE4,QXQ4,QXU,Q1,RA,RA2,RH,RHE,RHE4,RHQ4,RSC2,RTB2,RX,RXQ4,R1,SE,SH,SHE,SHEZ,SMS,SMX2,SNR,STP,STQ,SX,SXE,SXE4,SXQ4,SXU,S1,VA,VAH1,VA2,VDG2,VH,VH12,VMX,VTA,VTA2,VX,VXE,VXP,VXQP,VXQ4,VXQ7,VXQ7/A,VXU,VXU1,V1,WH,W1	
	16271-ZE2-010	(1)	-	-	LD,QD,RD,SD	
		1	(1)	1	ED4/A,ED5/A,ES1/A,ES2,HA2/A,HHQ4/A,HX/A,HXQ4/A,LH/A,LHE4/A,LJS/A,LSX/A,LX/A,LXF,LXQ4/A,LX2/A,L1/A,PA2/A,PMT2/A,PX/A,QAB2/A,QAE2/A,QAG2/A,QAR2/A,QA2/A,QC12/A,QE/A,QH/A,QHB2,QHP1/A,QHQ4/A,QMH/A,QTC2/A,QW24,QX/A,QXE/A,QXE4/A,QXQ4/A,QXU/A,Q1/A,RA2/A,RHQ4/A,RTB2/A,RX/A,RXQ4/A,R1/A,SE/A,SMS/A,SMX2/A,SNR/A,STP/A,STQ/A,SX/A,SXE4/A,SXQ4/A,SXU/A,S1/A,VA2/A,VDG2/A,VH/A,VH12/A,VTA2/A,VX/A,VXE/A,VXP/A,VXQ4/A,VXU/A,VXU1/A,W1/A	
		(1)	-	-	QD/A,RD/A,SD/A	



E-15-2

AIR CLEANER(3)

L 7

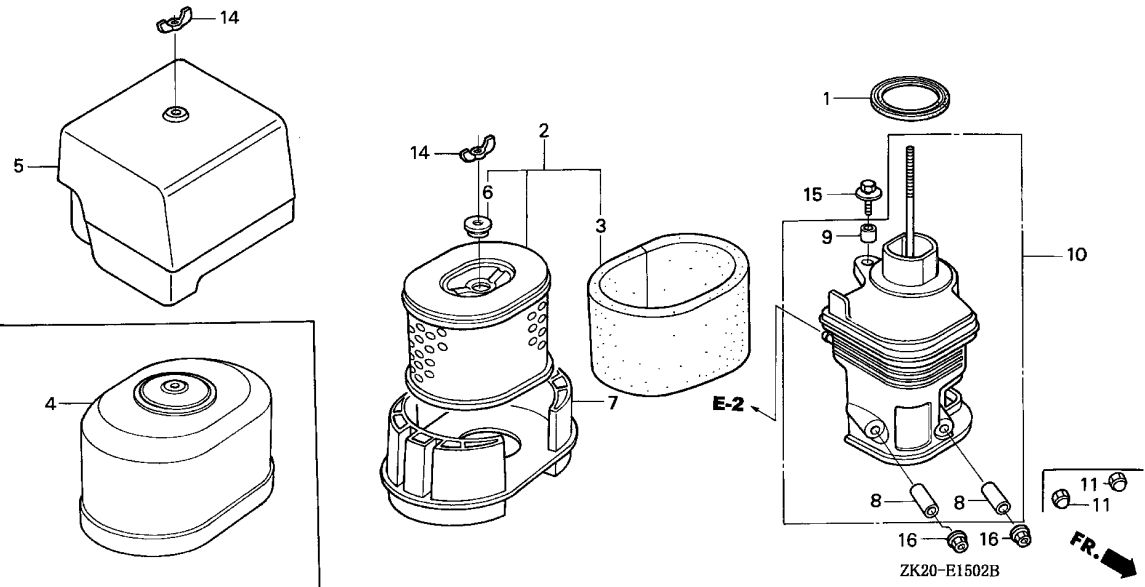

Ref. No.	Part No.	Description	Reqd. QTY			Serial No.	Parts catalogue code		
			(1)	(2)	(3)				
2	17210-ZE2-822	ELEMENT, AIR CLEANER (DUAL)	1	-	-	ED3,ED4,ED4/A,ED5,ED5/A,ES,ES1,ES1/A,ES2,HA,HAQ,HA2,HA2/A,HH,HHQ4,HHQ4/A,HX,HX/A,HXQ4,HXQ4/A,LH,LH/A,LHE,LHE4,LHE4/A,LHZ,LJS,LJS/A,LSX,LSX/A,LX,LX/A,LXF,LXQ4,LXQ4/A,LXZ,LX2,LX2/A,PA,PAE,PA2,PA2/A,PMT2,PMT2/A,PX,PX/A,QA,QAB2,QAB2/A,QAE,QAE2,QAE2/A,QAG,QAG/A,QAG2,QAG2/A,QAQ,QAQ4,QAR2,QAR2/A,QA2,QA2/A,QC12,QC12/A,QE,QE/A,QH,QH/A,QHB2,QHE,QHP1,QHP1/A,QHQ4,QHQ4/A,QHZ,QKA2,QMH,QMH/A,QMX2,QTC2,QTC2/A,QW24,QX,QX/A,QXE,QXE/A,QXE4,QXE4/A,QXQ4,QXQ4/A,QXU,QXU/A,RA,RA2,RA2/A,RH,RHE,RHE4,RHQ4,RHQ4/A,RSC2,RTB2,RTB2/A,RX,RX/A,RXQ4,RXQ4/A,SE,SE/A,SH,SHE,SHEZ,SMS,SMS/A,SMX2,SMX2/A,SNC1,SNE1,SNR,SNR/A,STP,STP/A,STQ,STQ/A,SX,SX/A,SXE,SXE4,SXE4/A,SXQ4,SXQ4/A,SXU,SXU/A,VA,VAH1,VA2,VA2/A,VDG2,VDG2/A,VH,VH/A,VH12,VH12/A,VMX,VTA,VTA2,VTA2/A,VX,VX/A,VXE,VXE/A,VXQ4,VXQ4/A,VXQ7,VXQ7/A,VXU,VXU/A,VXU1,VXU1/A,WH			
			(1)	-	-	LD,QD,QD/A,RD,RD/A,SD,SD/A			

Ref. No.	Part No.	Description	Reqd. QTY			Serial No.	Parts catalogue code
			(1)	(2)	(3)		
3	17218-ZE2-821	FILTER, OUTER	1	-	-	ED3,ED4,ED4/A,ED5,ED5/A,ES,ES1,ES1/A,ES2,HA,HAQ,HA2,HA2/A,HH,HHQ4,HHQ4/A,HX,HX/A,HXQ4,HXQ4/A,LH,LH/A,LHE,LHE4,LHE4/A,LHZ,LJS,LJS/A,LSX,LSX/A,LX,LX/A,LXF,LXQ4,LXQ4/A,LXZ,LX2,LX2/A,PA,PAE,PA2,PA2/A,PMT2,PMT2/A,PX,PX/A,QA,QAB2,QAB2/A,QAE,QAE2,QAE2/A,QAG,QAG/A,QAG2,QAG2/A,QAQ,QAQ4,QAR2,QAR2/A,QA2,QA2/A,QC12,QC12/A,QE,QE/A,QH,QH/A,QHB2,QHE,QHP1,QHP1/A,QHQ4,QHQ4/A,QHZ,QKA2,QMH,QMH/A,QMX2,QTC2,QTC2/A,QW24,QX,QX/A,QXE,QXE/A,QXE4,QXE4/A,QXQ4,QXQ4/A,QXU,QXU/A,RA,RA2,RA2/A,RH,RHE,RHE4,RHQ4,RHQ4/A,RSC2,RTB2,RTB2/A,RX,RX/A,RXQ4,RXQ4/A,SE,SE/A,SH,SHE,SHEZ,SMS,SMS/A,SMX2,SMX2/A,SNC1,SNE1,SNR,SNR/A,STP,STP/A,STQ,STQ/A,SX,SX/A,SXE,SXE4,SXE4/A,SXQ4,SXQ4/A,SXU,SXU/A,VA,VAH1,VA2,VA2/A,VDG2,VDG2/A,VH,VH/A,VH12,VH12/A,VMX,VTA,VTA2,VTA2/A,VX,VX/A,VXE,VXE/A,VXQ4,VXQ4/A,VXQ7,VXQ7/A,VXU,VXU/A,VXU1,VXU1/A,WH	
			(1)	-	-	LD,QD,QD/A,RD,RD/A,SD,SD/A	
			-	(1)	1		
4	17230-ZE2-820	COVER, AIR CLEANER (DUAL) ...	1	-	-	LJS,LJS/A,PMT2,PMT2/A	
			(1)	-	-	LD,QD,QD/A,RD,RD/A,SD,SD/A	
			-	(1)	-		
5	17231-ZH9-820	COVER, AIR CLEANER	1	-	-	ED3,ED4,ED4/A,ED5,ED5/A,ES,ES1,ES1/A,ES2,HA,HAQ,HA2,HA2/A,HH,HHQ4,HHQ4/A,HX,HX/A,HXQ4,HXQ4/A,LH,LH/A,LHE,LHE4,LHE4/A,LHZ,LSX,LSX/A,LX,LX/A,LXF,LXQ4,LXQ4/A,LXZ,LX2,LX2/A,PA,PAE,PA2,PA2/A,PX,PX/A,QA,QAB2,QAB2/A,QAE,QAE2,QAE2/A,QAG,QAG/A,QAQ,QAQ4,QAR2,QAR2/A,QA2,QA2/A,QC12,QC12/A,QE,QE/A,QH,QH/A,QHB2,QHE,QHP1,QHP1/A,QHQ4,QHQ4/A,QHZ,QKA2,QMH,QMH/A,QMX2,QTC2,QTC2/A,QW24,QX,QX/A,QXE,QXE/A,QXE4,QXE4/A,QXQ4,QXQ4/A,QXU,QXU/A,RA,RA2,RA2/A,RH,RHE,RHE4,RHQ4,RHQ4/A,RSC2,RTB2,RTB2/A,RX,RX/A,RXQ4,RXQ4/A,SE,SE/A,SH,SHE,SHEZ,SMS,SMS/A,SMX2,SMX2/A,SNC1,SNE1,SNR,SNR/A,STP,STP/A,STQ,STQ/A,SX,SX/A,SXE,SXE4,SXE4/A,SXQ4,SXQ4/A,SXU,SXU/A,VA,VAH1,VA2,VA2/A,VDG2,VDG2/A,VH,VH/A,VH12,VH12/A,VMX,VTA,VTA2,VTA2/A,VX,VX/A,VXE,VXE/A,VXQ4,VXQ4/A,VXQ7,VXQ7/A,VXU,VXU/A,VXU1,VXU1/A,WH	
			-	(1)	1		
6	17232-891-000	GROMMET, AIR CLEANER	1	-	-	ED3,ED4,ED4/A,ED5,ED5/A,ES,ES1,ES1/A,ES2,HA,HAQ,HA2,HA2/A,HH,HHQ4,HHQ4/A,HX,HX/A,HXQ4,HXQ4/A,LH,LH/A,LHE,LHE4,LHE4/A,LHZ,LJS,LJS/A,LSX,LSX/A,LX,LX/A,LXF,LXQ4,LXQ4/A,LXZ,LX2,LX2/A,PA,PAE,PA2,PA2/A,PMT2,PMT2/A,PX,PX/A,QA,QAB2,QAB2/A,QAE,QAE2,QAE2/A,QAG,QAG/A,QAG2,QAG2/A,QAQ,QAQ4,QAR2,QAR2/A,QA2,QA2/A,QC12,QC12/A,QE,QE/A,QH,QH/A,QHB2,QHE,QHP1,QHP1/A,QHQ4,QHQ4/A,QHZ,QKA2,QMH,QMH/A,QMX2,QTC2,QTC2/A,QW24,QX,QX/A,QXE,QXE/A,QXE4,QXE4/A,QXQ4,QXQ4/A,QXU,QXU/A,RA,RA2,RA2/A,RH,RHE,RHE4,RHQ4,RHQ4/A,RSC2,RTB2,RTB2/A,RX,RX/A,RXQ4,RXQ4/A,SE,SE/A,SH,SHE,SHEZ,SMS,SMS/A,SMX2,SMX2/A,SNC1,SNE1,SNR,SNR/A,STP,STP/A,STQ,STQ/A,SX,SX/A,SXE,SXE4,SXE4/A,SXQ4,SXQ4/A,SXU,SXU/A,VA,VAH1,VA2,VA2/A,VDG2,VDG2/A,VH,VH/A,VH12,VH12/A,VMX,VTA,VTA2,VTA2/A,VX,VX/A,VXE,VXE/A,VXQ4,VXQ4/A,VXQ7,VXQ7/A,VXU,VXU/A,VXU1,VXU1/A,WH	
			(1)	-	-	LD,QD,QD/A,RD,RD/A,SD,SD/A	
			-	(1)	1		
7	17235-ZE2-820	NOSE, SILENCER	1	-	-	HX,HX/A,HXQ4,HXQ4/A,LJS,LJS/A,LSX,LSX/A,LX,LX/A,LXF,LXQ4,LXQ4/A,LXZ,LX2,LX2/A,PMT2,PMT2/A,PX,PX/A,QA,QKA2,QMX2,QTC2,QTC2/A,QX,QX/A,QXE,QXE/A,QXE4,QXE4/A,QXQ4,QXQ4/A,QXU,QXU/A,RX,RX/A,RXQ4,RXQ4/A,SE,SE/A,SMX2,SMX2/A,SNE1,STP,STP/A,STQ,STQ/A,SX,SX/A,SXE,SXE4,SXE4/A,SXQ4,SXQ4/A,SXU,SXU/A,VMX,VX,VX/A,VXE,VXE/A,VXQ4,VXQ4/A,VXQ7,VXQ7/A,VXU,VXU/A,VXU1,VXU1/A	
			(1)	-	-	LD,QD,QD/A,RD,RD/A,SD,SD/A	
			-	(1)	1		



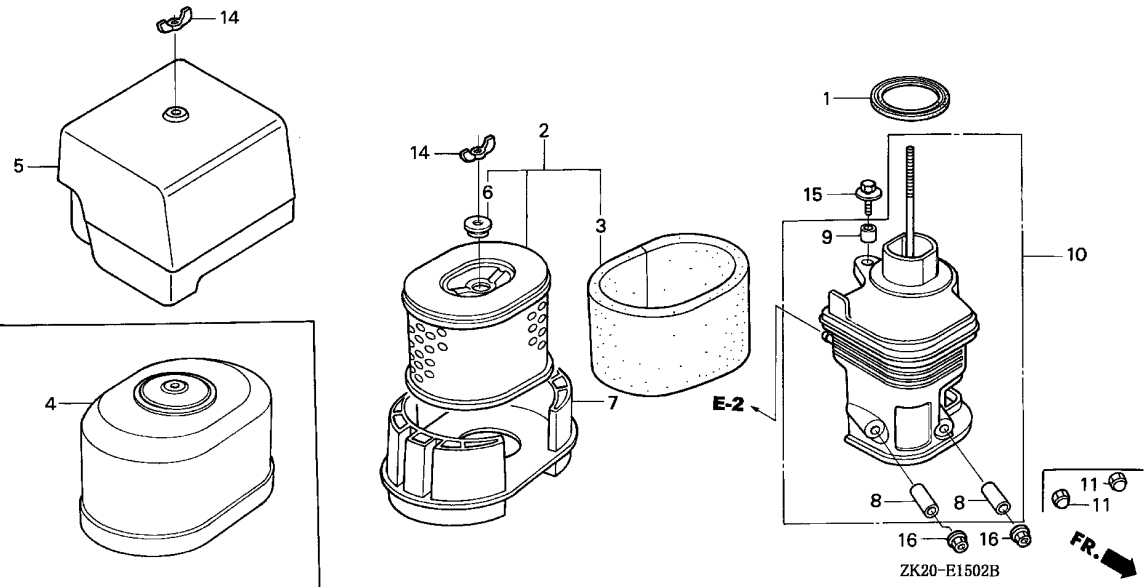

Ref. No.	Part No.	Description	Reqd. QTY			Serial No.	Parts catalogue code			
			(1)	(2)	(3)					
8	17238-ZE2-310	COLLAR, AIR CLEANER	2	-	-	ED3,ED4,ED4/A,ED5,ED5/A,ES,ES1,ES1/A,ES2,HA,HAQ,HA2,HA2/A,HH,HHQ4,HHQ4/A,HX,HX/A,HXQ4,HXQ4/A,LH,LH/A,LHE,LHE4,LHE4/A,LHZ,LJS,LJS/A,LSX,LSX/A,LX,LX/A,LXF,LXQ4,LXQ4/A,LXZ,LX2,LX2/A,PA,PAE,PA2,PA2/A,PMT2,PMT2/A,PX,PX/A,QA,QAB2,QAB2/A,QAE,QAE2,QAE2/A,QAG,QAG/A,QAG2,QAG2/A,QAQ,QAQ4,QAR2,QAR2/A,QA2,QA2/A,QC12,QC12/A,QE,QE/A,QH,QH/A,QHB2,QHE,QHP1,QHP1/A,QHQ4,QHQ4/A,QHZ,QKA2,QMH,QMH/A,QMX2,QTC2,QTC2/A,QW24,QX,QX/A,QXE,QXE/A,QXE4,QXE4/A,QXQ4,QXQ4/A,QXU,QXU/A,RA,RA2,RA2/A,RH,RHE,RHE4,RHQ4,RHQ4/A,RSC2,RTB2,RTB2/A,RX,RX/A,RXQ4,RXQ4/A,SE,SE/A,SH,SHE,SHEZ,SMS,SMS/A,SMX2,SMX2/A,SNC1,SNE1,SNR,SNR/A,STP,STP/A,STQ,STQ/A,SX,SX/A,SXE,SXE4,SXE4/A,SXQ4,SXQ4/A,SXU,SXU/A,VA,VAH1,VA2,VA2/A,VDG2,VDG2/A,VH,VH/A,VH12,VH12/A,VMX,VTA,VTA2,VTA2/A,VX,VX/A,VXE,VXE/A,VXQ4,VXQ4/A,VXQ7,VXQ7/A,VXU,VXU/A,VXU1,VXU1/A,WH	(2)	-	-	LD,QD,QD/A,RD,RD/A,SD,SD/A
			-	(2)	2					

E-15-2

AIR CLEANER(3)

L10

Ref. No.	Part No.	Description	Reqd. QTY			Serial No.	Parts catalogue code
			(1)	(2)	(3)		
9	17239-ZE1-000	COLLAR B, AIR CLEANER	1	-	-	-----	ED3,ED4,ED4/A,ED5,ED5/A,ES,ES1,ES1/A,ES2,HA,HAQ,HA2,HA2/A,HH,HHQ4,HHQ4/A,HX,HX/A,HXQ4,HXQ4/A,LH,LH/A,LHE,LHE4,LHE4/A,LHZ,LJS,LJS/A,LSX,LSX/A,LX,LX/A,LXF,LXQ4,LXQ4/A,LXZ,LX2,LX2/A,PA,PAE,PA2,PA2/A,PMT2,PMT2/A,PX,PX/A,QA,QAB2,QAB2/A,QAE,QAE2,QAE2/A,QAG,QAG/A,QAG2,QAG2/A,QAQ,QAQ4,QAR2,QAR2/A,QA2,QA2/A,QC12,QC12/A,QE,QE/A,QH,QH/A,QHB2,QHE,QHP1,QHP1/A,QHQ4,QHQ4/A,QHZ,QKA2,QMH,QMH/A,QMX2,QTC2,QTC2/A,QW24,QX,QX/A,QXE,QXE/A,QXE4,QXE4/A,QXQ4,QXQ4/A,QXU,QXU/A,RA,RA2,RA2/A,RH,RHE,RHE4,RHQ4,RHQ4/A,RSC2,RTB2,RTB2/A,RX,RX/A,RXQ4,RXQ4/A,SE,SE/A,SH,SHE,SHEZ,SMS,SMS/A,SMX2,SMX2/A,SNC1,SNE1,SNR,SNR/A,STP,STP/A,STQ,STQ/A,SX,SX/A,SXE,SXE4,SXE4/A, SXQ4, SXQ4/A, SXU, SXU/A, VA, VAH1, VA2, VA2/A, VDG2, VDG2/A, VH, VH/A, VH12, VH12/A, VMX, VTA, VTA2, VTA2/A, VX, VX/A, VXE, VXE/A, VXQ4, VXQ4/A, VXQ7, VXQ7/A, VXU, VXU/A, VXU1, VXU1/A, WH
			(1)	-	-	-----	LD, QD, QD/A, RD, RD/A, SD, SD/A
			-	(1)	1		
10	17410-ZE2-020	ELBOW COMP., AIR CLEANER	1	-	-	-----	ED3,ED4,ED4/A,ED5,ED5/A,ES,ES1,ES1/A,ES2,HA,HAQ,HA2,HA2/A,HH,HHQ4,HHQ4/A,HX,HX/A,HXQ4,HXQ4/A,LH,LH/A,LHE,LHE4,LHE4/A,LHZ,LJS,LJS/A,LSX,LSX/A,LX,LX/A,LXF,LXQ4,LXQ4/A,LXZ,LX2,LX2/A,PA,PAE,PA2,PA2/A,PMT2,PMT2/A,PX,PX/A,QA,QAB2,QAB2/A,QAE,QAE2,QAE2/A,QAG,QAG/A,QAG2,QAG2/A,QAQ,QAQ4,QAR2,QAR2/A,QA2,QA2/A,QC12,QC12/A,QE,QE/A,QH,QH/A,QHB2,QHE,QHP1,QHP1/A,QHQ4,QHQ4/A,QHZ,QKA2,QMH,QMH/A,QMX2,QTC2,QTC2/A,QW24,QX,QX/A,QXE,QXE/A,QXE4,QXE4/A,QXQ4,QXQ4/A,QXU,QXU/A,RA,RA2,RA2/A,RH,RHE,RHE4,RHQ4,RHQ4/A,RSC2,RTB2,RTB2/A,RX,RX/A,RXQ4,RXQ4/A,SE,SE/A,SH,SHE,SHEZ,SMS,SMS/A,SMX2,SMX2/A,SNC1,SNE1,SNR,SNR/A,STP,STP/A,STQ,STQ/A,SX,SX/A,SXE,SXE4,SXE4/A, SXQ4, SXQ4/A, SXU, SXU/A, VA, VAH1, VA2, VA2/A, VDG2, VDG2/A, VH, VH/A, VH12, VH12/A, VMX, VTA, VTA2, VTA2/A, VX, VX/A, VXE, VXE/A, VXQ4, VXQ4/A, VXQ7, VXQ7/A, VXU, VXU/A, VXU1, VXU1/A, WH
			(1)	-	-	-----	LD, QD, QD/A, RD, RD/A, SD, SD/A
			-	(1)	1		
11	90201-415-000	NUT, CAP, 6MM	2	2	-	-----	3165927 ED3,ED4,ED5,ES,ES1,HH,HX,LH,LHE,LX,LXZ,L1,PX,P1,QA,QAE,QE,QH,QHE,QX,QXE,Q1,RH,RHE,RX,R1,SE,SH,SHE,SHEZ,SNR,STP,STQ,SX,SXE,S1,VH,VX,VXE,V1,WH,W1
			2	-	-	-----	3165402 HA,HAQ,PA,QAQ,RA,VA,VAH1,VTA
			(2)	-	-	-----	3165927 LD,QD,RD,SD
14	90325-044-000	NUT, TOOL BOX SETTING	2	-	-	-----	ED3,ED4,ED4/A,ED5,ED5/A,ES,ES1,ES1/A,ES2,HA,HAQ,HA2,HA2/A,HH,HHQ4,HHQ4/A,HX,HX/A,HXQ4,HXQ4/A,LH,LH/A,LHE,LHE4,LHE4/A,LHZ,LJS,LJS/A,LSX,LSX/A,LX,LX/A,LXF,LXQ4,LXQ4/A,LXZ,LX2,LX2/A,PA,PAE,PA2,PA2/A,PMT2,PMT2/A,PX,PX/A,QA,QAB2,QAB2/A,QAE,QAE2,QAE2/A,QAG,QAG/A,QAG2,QAG2/A,QAQ,QAQ4,QAR2,QAR2/A,QA2,QA2/A,QC12,QC12/A,QE,QE/A,QH,QH/A,QHB2,QHE,QHP1,QHP1/A,QHQ4,QHQ4/A,QHZ,QKA2,QMH,QMH/A,QMX2,QTC2,QTC2/A,QW24,QX,QX/A,QXE,QXE/A,QXE4,QXE4/A,QXQ4,QXQ4/A,QXU,QXU/A,RA,RA2,RA2/A,RH,RHE,RHE4,RHQ4,RHQ4/A,RSC2,RTB2,RTB2/A,RX,RX/A,RXQ4,RXQ4/A,SE,SE/A,SH,SHE,SHEZ,SMS,SMS/A,SMX2,SMX2/A,SNC1,SNE1,SNR,SNR/A,STP,STP/A,STQ,STQ/A,SX,SX/A,SXE,SXE4,SXE4/A, SXQ4, SXQ4/A, SXU, SXU/A, VA, VAH1, VA2, VA2/A, VDG2, VDG2/A, VH, VH/A, VH12, VH12/A, VMX, VTA, VTA2, VTA2/A, VX, VX/A, VXE, VXE/A, VXQ4, VXQ4/A, VXQ7, VXQ7/A, VXU, VXU/A, VXU1, VXU1/A, WH
			(2)	-	-	-----	LD, QD, QD/A, RD, RD/A, SD, SD/A
			-	(2)	2		

2

E-15-2

AIR CLEANER(3)

L11

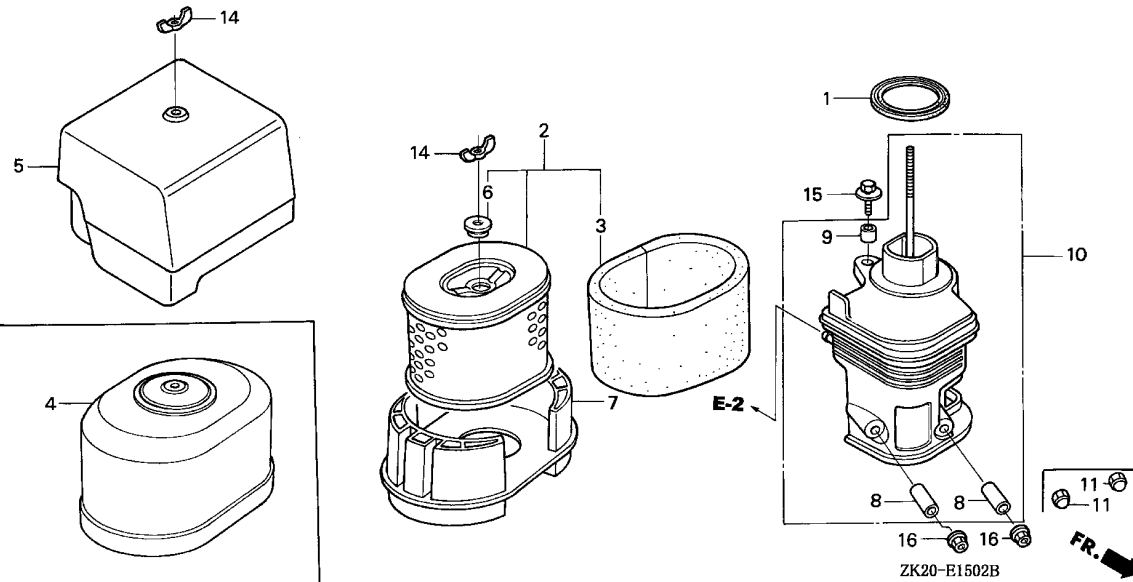

Ref. No.	Part No.	Description	Reqd. QTY			Serial No.	Parts catalogue code
			(1)	(2)	(3)		
15	93494-06020-08	BOLT-WASHER, 6X20	1	1	1	-----	ED3,ED4,ED5,ES,ES1,HA,HAQ,HA2,HH,HHQ4,HX,HXQ4,LH,LHE,LHE4,LHZ,LJS LSX,LX,LXQ4,LXZ,LX2,L1,PA,PAE,PA2,PMT2,PX,P1,QA,QAB2,QAE,QAE2 QAG2,QAQ,QAQ4,QAR2,QA2,QC12,QE,QH,QHE,QHP1,QHQ4,QHZ,QKA2,QMH,QMX2 QTC2,QX,QXE,QXE4,QXQ4,QXU,Q1,RA,RA2,RH,RHE,RHE4,RHQ4,RSC2,RTB2,RX RXQ4,R1,SE,SH,SHE,SHEZ,SMS,SMX2,SNC1,SNE1,SNR,STP,STQ,SX,SXE,SXE4 SXQ4,SXU,S1,VA,VAH1,VA2,VDG2,VH,VH12,VMX,VTA,VTA2,VX,VXE,VXP,VXQP VXQ4,VXU,VXU1,V1,WH,W1
			(1)	-	-	-----	LD,QD,RD,SD
	90009-ZE2-003	BOLT-WASHER, 6X22	1	1	1	-----	ED4/A,ED5/A,ES1/A,ES2,HA2/A,HHQ4/A,HX/A,HXQ4/A,LH/A,LHE4/A,LJS/A LSX/A,LX/A,LXF,LXQ4/A,LX2/A,L1/A,PA2/A,PMT2/A,PX/A,QAB2/A,QAE2/A QAG,QAG/A,QAG2/A,QAR2/A,QA2/A,QC12/A,QE/A,QH/A,QHB2,QHP1/A,QHQ4/A QMH/A,QTC2/A,QW24,QX/A,QXE/A,QXE4/A,QXQ4/A,QXU/A,Q1/A,RA2/A RHQ4/A,RTB2/A,RX/A,RXQ4/A,R1/A,SE/A,SMS/A,SMX2/A,SNR/A,STP/A STQ/A,SX/A,SXE4/A,SXQ4/A,SXU/A,S1/A,VA2/A,VDG2/A,VH/A,VH12/A VTA2/A,VX/A,VXE/A,VXP/A,VXQ4/A,VXQ7/VXQ7/A,VXU/A,VXU1/A,W1/A
			(1)	-	-	-----	QD/A,RD/A,SD/A

E-15-2

AIR CLEANER(3)

L12

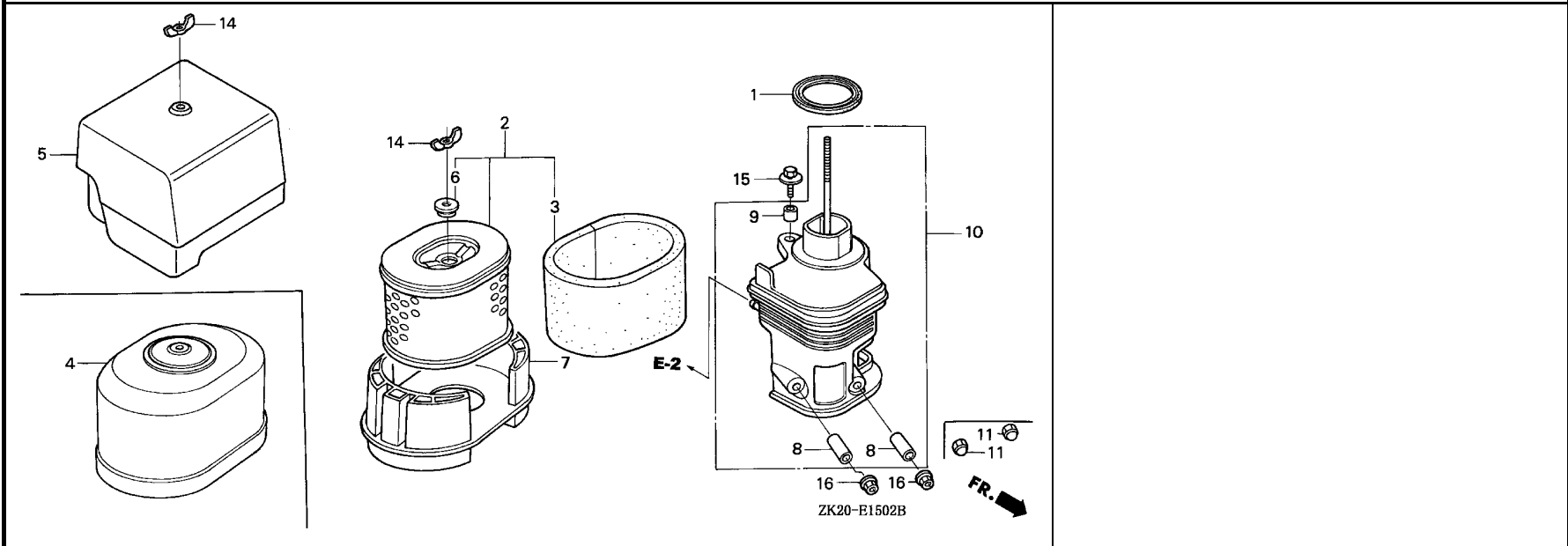

2

Ref. No.	Part No.	Description	Reqd. QTY			Serial No.	Parts catalogue code
			(1)	(2)	(3)		
16	94050-06000	NUT, FLANGE, 6MM	2	2	-	ED4/A, ED5/A, ES1/A, ES2, HA2, HA2/A, HHQ4, HHQ4/A, HX/A, HXQ4, HXQ4/A, LH/A, LHE4, LHE4/A, LHZ, LJS, LJS/A, LSX, LSX/A, LX/A, LXF, LXQ4, LXQ4/A, LX2, LX2/A, L1/A, PAE, PA2, PA2/A, PMT2, PMT2/A, PX/A, QAB2, QAB2/A, QAE2, QAE2/A, QAG, QAG/A, QAG2, QAG2/A, QAQ4, QAR2, QAR2/A, QA2, QA2/A, QC12, QC12/A, QE/A, QH/A, QHB2, QHP1, QHP1/A, QHQ4, QHQ4/A, QHZ, QKA2, QMH, QMH/A, QMX2, QTC2, QTC2/A, QW24, QX/A, QXE/A, QXE4, QXE4/A, QXQ4, QXQ4/A, QXU, QXU/A, Q1/A, RA2, RA2/A, RHE4, RHQ4, RHQ4/A, RSC2, RTB2, RTB2/A, RX/A, RXQ4, RXQ4/A, R1/A, SE/A, SMS, SMS/A, SMX2, SMX2/A, SNC1, SNE1, SNR/A, STP/A, STQ/A, SX/A, SXE4, SXE4/A, SXQ4, SXQ4/A, SXU, SXU/A, S1/A, VA2, VA2/A, VDG2, VDG2/A, VH/A, VH12, VH12/A, VMX, VTA2, VTA2/A, VX/A, VXE/A, VXQ4, VXQ4/A, VXQ7, VXQ7/A, VXU, VXU/A, VXU1, VXU1/A, W1/A	
			2	2	-	3165928	ED3, ED4, ED5, ES, ES1, HH, HX, LH, LHE, LX, LXZ, L1, PX, P1, QA, QAE, QE, QH, QHE, QX, QXE, Q1, RH, RHE, RX, R1, SE, SH, SHE, SHEZ, SNR, STP, STQ, SX, SXE, S1, VH, VX, VXE, V1, WH, W1
			2	-	-	3165403	HA, HAQ, PA, QAQ, RA, VA, VAH1, VTA
			(2)	-	-		QD/A, RD/A, SD/A
			(2)	-	-	3165928	LD, QD, RD, SD
			-	-	2		

E-15-3

AIR CLEANER(4)

L13

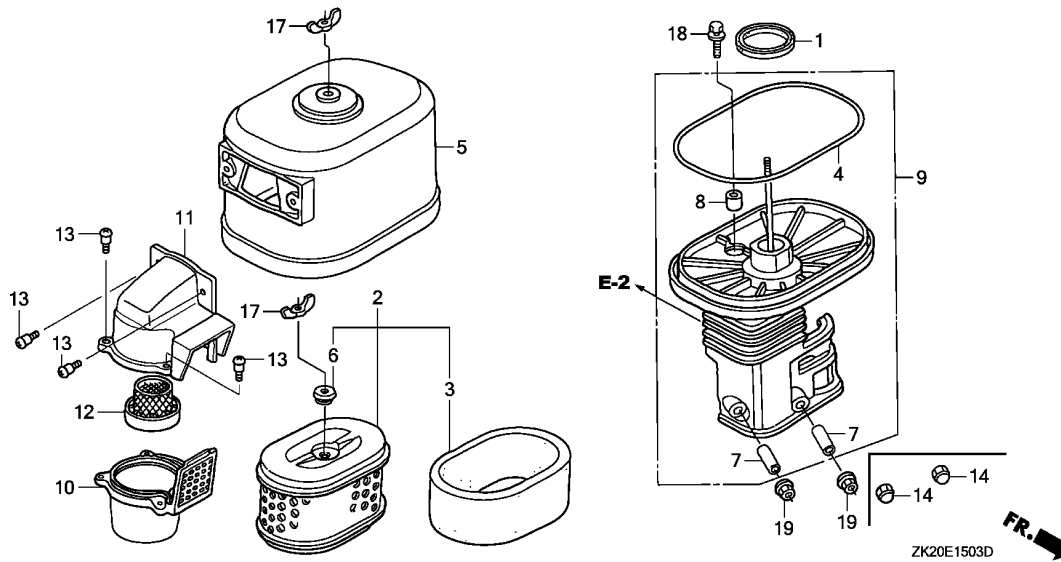

Ref. No.	L.O.N.	(Relative ref. Number) Description	F.R.T.
1	3121E1	PACKING, ELBOW	0.1
2	3121B8	ELEMENT, AIR CLEANER	0.1
3	3121C1	FILTER, OUTER	0.1
4	3121E0	PACKING, AIR CLEANER COVER ...	0.1
5	3121B1	COVER, AIR CLEANER	0.1
9	3121B4	ELBOW, AIR CLEANER	0.1
10	3121A6	CASE, PRE AIR CLEANER	0.1
11	3121A4	CAP, PRE AIR CLEANER	0.1
12	3121C8	GUIDE, PRE AIR CLEANER	0.1

Ref. No.	Part No.	Description	Reqd. QTY			Serial No.	Parts catalogue code
			(1)	(2)	(3)		
			GX240K1				
1	16271-ZE2-000	PACKING, ELBOW	1	(1)	-	LSS4,L1,P1,QHC,QXC,QXC9,Q1,R1,S1,V1,W1	
	16271-ZE2-010	1	(1)	-	L1/A,QXC/A,QXC9/A,Q1/A,R1/A,S1/A,W1/A	
2	17210-ZE3-010	ELEMENT, AIR CLEANER	1	-	-	LSS4,QHC,QXC,QXC/A,QXC9,QXC9/A	
			-	(1)	-		
3	17218-ZE3-000	FILTER, OUTER	1	-	-	LSS4,QHC,QXC,QXC/A,QXC9,QXC9/A	
			-	(1)	-		
4	17219-ZE3-840	PACKING, AIR CLEANER COVER ..	1	-	-	LSS4,QHC,QXC,QXC/A,QXC9,QXC9/A	
			-	(1)	-		
5	17230-ZE3-841	COVER COMP., AIR CLEANER (CYCLONE)	1	-	-	LSS4,QHC,QXC,QXC/A,QXC9,QXC9/A	
			-	(1)	-		
6	17232-891-000	GROMMET, AIR CLEANER	1	-	-	LSS4,QHC,QXC,QXC/A,QXC9,QXC9/A	
			-	(1)	-		
7	17238-ZE2-310	COLLAR, AIR CLEANER	2	-	-	LSS4,QHC,QXC,QXC/A,QXC9,QXC9/A	
			-	(2)	-		
8	17239-ZE3-840	COLLAR B, AIR CLEANER	1	-	-	LSS4,QHC,QXC,QXC/A,QXC9,QXC9/A	
			-	(1)	-		
9	17410-ZE3-840	ELBOW COMP., AIR CLEANER	1	-	-	LSS4,QHC,QXC,QXC/A,QXC9,QXC9/A	
			-	(1)	-		
10	17470-ZE3-841	CASE COMP., PRE AIR CLEANER ..	1	(1)	-	L1,QHC,QXC,QXC9,Q1,R1,S1,V1,W1	
	17470-ZE3-842	1	(1)	-	LSS4,L1/A,QXC/A,QXC9/A,Q1/A,R1/A,S1/A,W1/A	
11	17475-ZE3-841	CAP, PRE AIR CLEANER	1	-	-	LSS4,QHC,QXC,QXC/A,QXC9,QXC9/A	
			-	(1)	-		
12	17476-ZE3-841	GUIDE, PRE AIR CLEANER	1	-	-	LSS4,QHC,QXC,QXC/A,QXC9,QXC9/A	
			-	(1)	-		
13	90142-MB0-000	SCREW, PAN, 5X16.5	5	-	-	LSS4,QHC,QXC,QXC/A,QXC9,QXC9/A	
			-	(5)	-		

E-15-3

AIR CLEANER(4)

L14

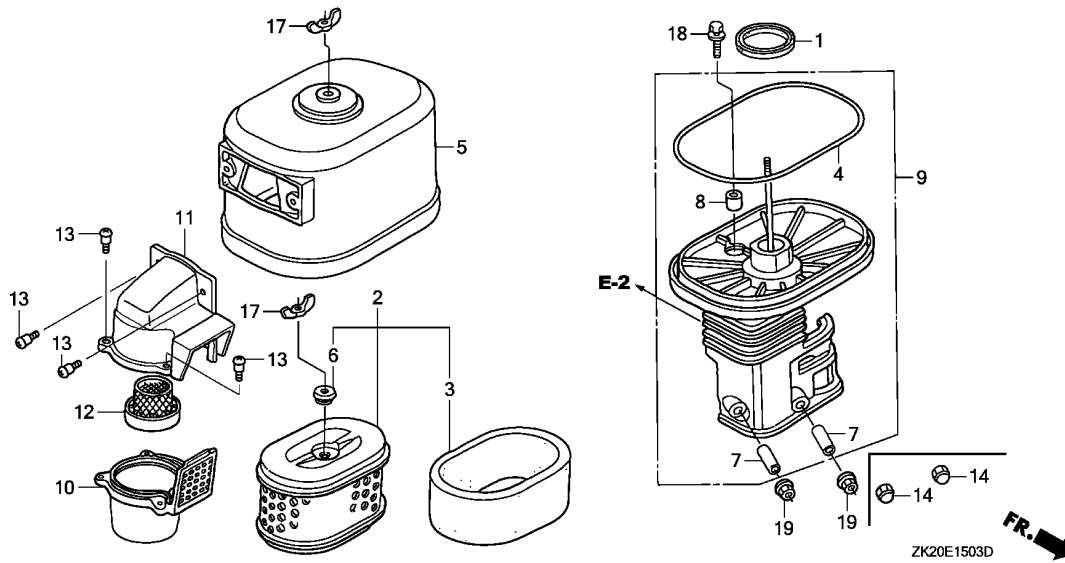

Ref. No.	Part No.	Description	Reqd. QTY			Serial No.	Parts catalogue code
			GX240K1				
			(1)	(2)	(3)		
14	90201-415-000	NUT, CAP, 6MM	2	2	-	3165927	L1,P1,QHC,QXC,Q1,R1,S1,V1,W1
17	90325-044-000	NUT, TOOL BOX SETTING	2	-	-	-	LSS4,QHC,QXC,QXC/A,QXC9,QXC9/A
18	93494-06020-08	BOLT-WASHER, 6X20	1	1	-	-	LSS4,L1,P1,QHC,QXC,QXC9,Q1,R1,S1,V1,W1
	90009-ZE2-003	BOLT-WASHER, 6X22	1	1	-	-	L1/A,QXC/A,QXC9/A,Q1/A,R1/A,S1/A,W1/A
19	94050-06000	NUT, FLANGE, 6MM	2	2	-	-	LSS4,L1/A,QXC/A,QXC9,QXC9/A,Q1/A,R1/A,S1/A,W1/A
			2	2	-	3165928	L1,P1,QHC,QXC,Q1,R1,S1,V1,W1

2

E-15-4

AIR CLEANER(5)

L15

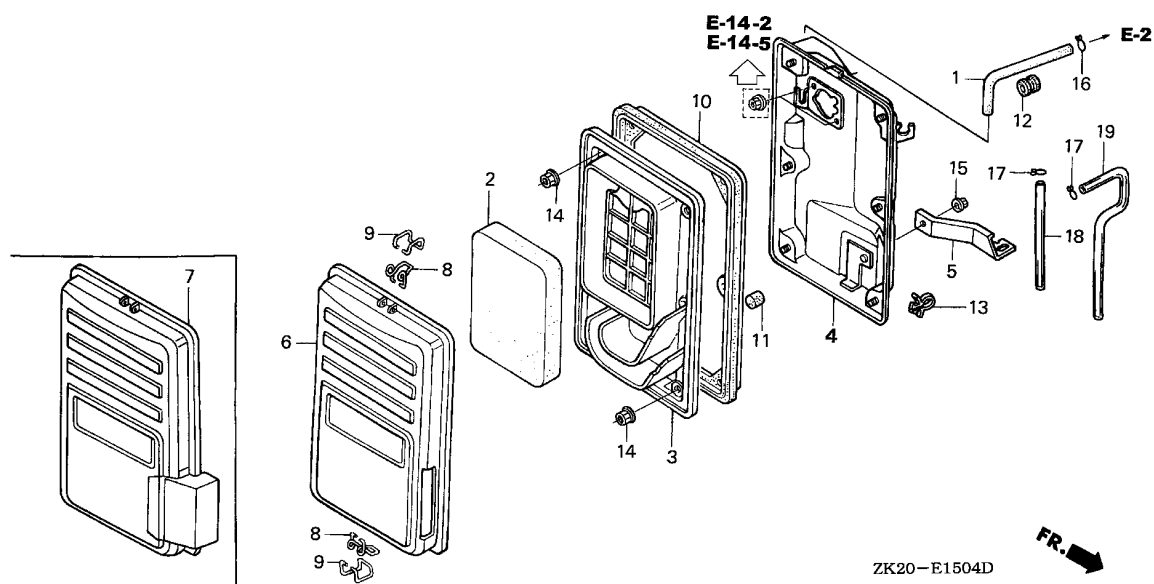

Ref. No.	L.O.N.	(Relative ref. Number) Description	F.R.T.
1	1111K5	TUBE, BREATHER	0.1
2	3121B8	ELEMENT, AIR CLEANER	0.1
3	3121F0	SEPARATOR, AIR CLEANER	0.1
4	3121A5	CASE, AIR CLEANER	0.1
10	3121E8	SEAL, AIR CLEANER CASE	0.1

2

Ref. No.	Part No.	Description	Reqd. QTY			Serial No.	Parts catalogue code
			(1)	(2)	(3)		
1	15721-ZB4-000	TUBE, BREATHER	1	-	-	EDN,EDN2,EDN2/A,EDS,EDS1,EDS1/A,EDS2,EDS2/A,EDS3,EDS6,EDS6/A,EDT1/A,EDT2,EDT3,EDT6,EDT6/A,ED2,ED2/A,EN2,EN2/A,ES3,ES3/A,VMT2 VSB1,VSB1/A,VS3,VS4,VTE2,WKA	
	15721-ZB7-000	1	-	-	EDS5	
2	17211-899-000	ELEMENT, AIR CLEANER	1	-	-	EDN,EDN2,EDN2/A,EDS,EDS1,EDS1/A,EDS2,EDS2/A,EDS3,EDS5,EDS6,EDS6/A EDT1,EDT1/A,EDT2,EDT3,EDT6,EDT6/A,ED2,ED2/A,EN2,EN2/A,ES3,ES3/A VMT2,VSB1,VSB1/A,VS3,VS4,VTE2,WKA	
3	17212-ZB4-003	SEPARATOR, AIR CLEANER	1	-	-	EDN,EDN2,EDN2/A,EDS,EDS1,EDS1/A,EDS2,EDS2/A,EDS3,EDS5,EDS6,EDS6/A EDT1,EDT1/A,EDT2,EDT3,EDT6,EDT6/A,ED2,ED2/A,EN2,EN2/A,ES3,ES3/A VMT2,VSB1,VSB1/A,VS3,VS4,VTE2,WKA	
4	17220-ZB4-003	CASE COMP., AIR CLEANER	1	-	-	EDN,EDN2,EDN2/A,EDS,EDS1,EDS1/A,EDS2,EDS2/A,EDS3,EDS6,EDS6/A,EDT1 EDT1/A,EDT2,EDT3,EDT6,EDT6/A,ED2,ED2/A,EN2,EN2/A,ES3,ES3/A,VMT2 VSB1,VSB1/A,VS3,VS4,VTE2	
	17220-ZB7-000	1	-	-	EDS5,WKA	
5	17222-ZB4-000	STAY, AIR CLEANER	1	-	-	EDN,EDN2,EDN2/A,EDS,EDS1,EDS1/A,EDS2,EDS2/A,EDS3,EDS6,EDS6/A,EDT1 EDT1/A,EDT2,EDT3,EDT6,EDT6/A,ED2,ED2/A,EN2,EN2/A,ES3,ES3/A,VMT2 VSB1,VSB1/A,VS3,VS4,VTE2	
	17222-ZB7-000	1	-	-	EDS5,WKA	
6	17231-899-000	COVER COMP., AIR CLEANER	1	-	-	EDN,EDN2,EDN2/A,EDS,EDS1,EDS1/A,EDS2,EDS2/A,EDS3,EDS6,EDS6/A,EDT1 EDT1/A,EDT2,EDT3,EDT6,EDT6/A,ED2,ED2/A,EN2,EN2/A,ES3,ES3/A,VMT2 VSB1,VSB1/A,VS3,VS4,VTE2	
7	17231-ZB7-000	COVER COMP., AIR CLEANER	1	-	-	EDS5,WKA	
8	17235-899-000	CLIP A, AIR CLEANER WIRE	2	-	-	EDN,EDN2,EDN2/A,EDS,EDS1,EDS1/A,EDS2,EDS2/A,EDS3,EDS5,EDS6,EDS6/A EDT1,EDT1/A,EDT2,EDT3,EDT6,EDT6/A,ED2,ED2/A,EN2,EN2/A,ES3,ES3/A VMT2,VSB1,VSB1/A,VS3,VS4,VTE2,WKA	
9	17236-899-000	CLIP B, AIR CLEANER WIRE	2	-	-	EDN,EDN2,EDN2/A,EDS,EDS1,EDS1/A,EDS2,EDS2/A,EDS3,EDS5,EDS6,EDS6/A EDT1,EDT1/A,EDT2,EDT3,EDT6,EDT6/A,ED2,ED2/A,EN2,EN2/A,ES3,ES3/A VMT2,VSB1,VSB1/A,VS3,VS4,VTE2,WKA	

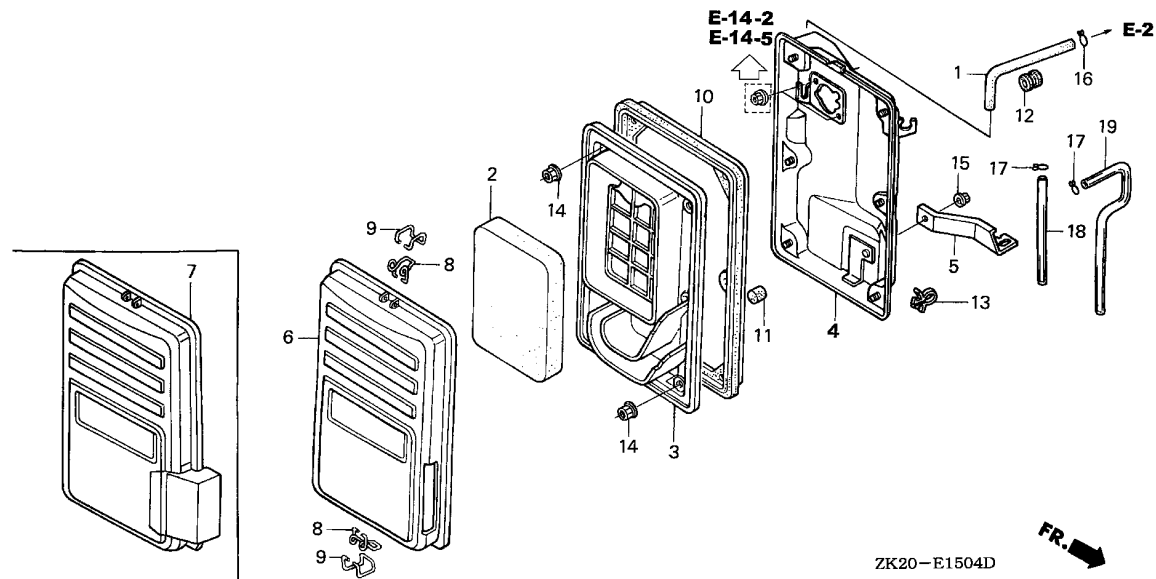

Ref. No.	Part No.	Description	Reqd. QTY			Serial No.	Parts catalogue code
			(1)	(2)	(3)		
10	17252-899-000	SEAL, AIR CLEANER	1	-	-	-----	EDN,EDN2,EDN2/A,EDS,EDS1,EDS1/A,EDS2,EDS2/A,EDS3,EDS5,EDS6,EDS6/A EDT1,EDT1/A,EDT2,EDT3,EDT6,EDT6/A,ED2,ED2/A,EN2,EN2/A,ES3,ES3/A VMT2,VSB1,VSB1/A,VS3,VS4,VTE2,WKA
11	17367-413-690	FILTER, DRAIN TUBE	1	-	-	-----	EDN,EDN2,EDN2/A,EDS,EDS1,EDS1/A,EDS2,EDS2/A,EDS3,EDS5,EDS6,EDS6/A EDT1,EDT1/A,EDT2,EDT3,EDT6,EDT6/A,ED2,ED2/A,EN2,EN2/A,ES3,ES3/A VMT2,VSB1,VSB1/A,VS3,VS4,VTE2,WKA
12	88911-MJ3-000	GROMMET, FENDER	1	-	-	-----	EDS5,VMT2,WKA
13	90624-SB0-003	CLIP, WIRE HARNESS	1	-	-	-----	EDS5,WKA
14	94050-05000	NUT, FLANGE, 5MM	6	-	-	-----	EDN,EDN2,EDN2/A,EDS,EDS1,EDS1/A,EDS2,EDS2/A,EDS3,EDS5,EDS6,EDS6/A EDT1,EDT1/A,EDT2,EDT3,EDT6,EDT6/A,ED2,ED2/A,EN2,EN2/A,ES3,ES3/A VMT2,VSB1,VSB1/A,VS3,VS4,VTE2,WKA
15	94050-06000	NUT, FLANGE, 6MM	1	-	-	-----	EDN,EDN2,EDN2/A,EDS,EDS1,EDS1/A,EDS2,EDS2/A,EDS3,EDS5,EDS6,EDS6/A EDT1,EDT1/A,EDT2,EDT3,EDT6,EDT6/A,ED2,ED2/A,EN2,EN2/A,ES3,ES3/A VMT2,VSB1,VSB1/A,VS3,VS4,VTE2,WKA
16	15772-292-010	CLIP, BREATHER TUBE	1	-	-	-----	EDS5
17	95002-45000	CLIP, TUBE (C8)	2	-	-	-----	EDS5
18	95003-09023-31	TUBE, VINYL, 4.5X8X230 (95003-09001-60M)	1	-	-	-----	EDS5
19	95003-09038-31	TUBE, VINYL, 4.5X8X380 (95003-09001-60M)	1	-	-	-----	EDS5



E-15-5

AIR CLEANER(6)

M 1

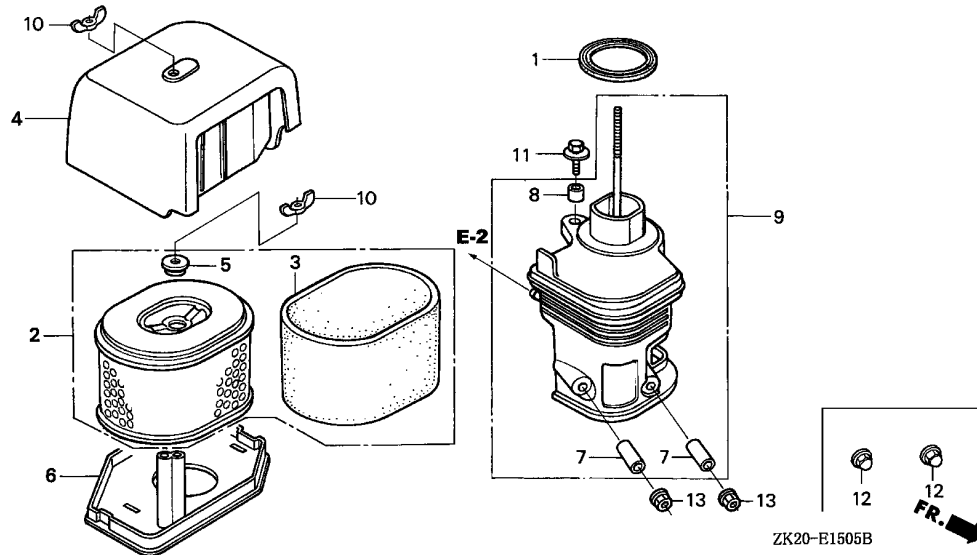

Ref. No.	L.O.N.	(Relative ref. Number) Description	F.R.T.
1	3121E1	PACKING, ELBOW	0.1
2	3121B8	ELEMENT, AIR CLEANER	0.1
3	3121C1	FILTER, OUTER	0.1
9	3121B4	ELBOW, AIR CLEANER	0.1

Ref. No.	Part No.	Description	Reqd. QTY			Serial No.	Parts catalogue code
			(1)	(2)	(3)		
1	16271-ZE2-000	PACKING, ELBOW	1	-	-	QXB,QXB7,QXB7/A,QXEB,SXB,SXEB,VNG,VWC2,VXB,VXB7,VXB7/A,VXEB	
	16271-ZE2-010	1	-	-	VWC2/A,VXB/A,VXEB/A	
2	17210-ZE3-010	ELEMENT, AIR CLEANER	1	-	-	QXB,QXB7,QXB7/A,QXEB,SXB,SXEB,VNG,VWC2,VWC2/A,VXB,VXB/A,VXB7	
					VXB7/A,VXEB,VXEB/A	
3	17218-ZE3-000	FILTER, OUTER	1	-	-	QXB,QXB7,QXB7/A,QXEB,SXB,SXEB,VNG,VWC2,VWC2/A,VXB,VXB/A,VXB7	
					VXB7/A,VXEB,VXEB/A	
4	17231-ZH9-N00	COVER, AIR CLEANER (100DB) ..	1	-	-	QXB,QXEB,SXB,SXEB,VNG	
	17231-ZH9-N01	1	-	-	QXB7,QXB7/A,VWC2,VWC2/A,VXB,VXB/A,VXB7,VXB7/A,VXEB,VXEB/A	
5	17232-891-000	GROMMET, AIR CLEANER	1	-	-	QXB,QXB7,QXB7/A,QXEB,SXB,SXEB,VNG,VWC2,VWC2/A,VXB,VXB/A,VXB7	
					VXB7/A,VXEB,VXEB/A	
6	17235-ZH9-N00	NOSE, SILENCER	1	-	-	QXB,QXB7,QXB7/A,QXEB,SXB,SXEB,VNG,VWC2,VWC2/A,VXB,VXB/A,VXB7	
					VXB7/A,VXEB,VXEB/A	
7	17238-ZE2-310	COLLAR, AIR CLEANER	2	-	-	QXB,QXB7,QXB7/A,QXEB,SXB,SXEB,VNG,VWC2,VWC2/A,VXB,VXB/A,VXB7	
					VXB7/A,VXEB,VXEB/A	
8	17239-ZE1-000	COLLAR B, AIR CLEANER	1	-	-	QXB,QXB7,QXB7/A,QXEB,SXB,SXEB,VNG,VWC2,VWC2/A,VXB,VXB/A,VXB7	
					VXB7/A,VXEB,VXEB/A	
9	17410-ZH9-N00	ELBOW COMP., AIR CLEANER	1	-	-	QXB,QXB7,QXB7/A,QXEB,SXB,SXEB,VNG,VWC2,VWC2/A,VXB,VXB/A,VXB7	
					VXB7/A,VXEB,VXEB/A	
10	90325-044-000	NUT, TOOL BOX SETTING	2	-	-	QXB,QXB7,QXB7/A,QXEB,SXB,SXEB,VNG,VWC2,VWC2/A,VXB,VXB/A,VXB7	
					VXB7/A,VXEB,VXEB/A	
11	93494-06020-08	BOLT-WASHER, 6X20	1	-	-	QXB,QXEB,SXB,SXEB,VNG,VWC2,VXB,VXEB	
	90009-ZE2-003	BOLT-WASHER, 6X22	1	-	-	QXB7,QXB7/A,VWC2/A,VXB/A,VXB7,VXB7/A,VXEB/A	
12	90201-415-000	NUT, CAP, 6MM	2	-	-	3165927 QXB,QXEB,SXB,SXEB,VNG,VXB,VXEB	
13	94050-06000	NUT, FLANGE, 6MM	2	-	-	QXB7,QXB7/A,VWC2,VWC2/A,VXB/A,VXB7,VXB7/A,VXEB/A	
		2	-	-	3165928 QXB,QXEB,SXB,SXEB,VNG,VXB,VXEB	

2

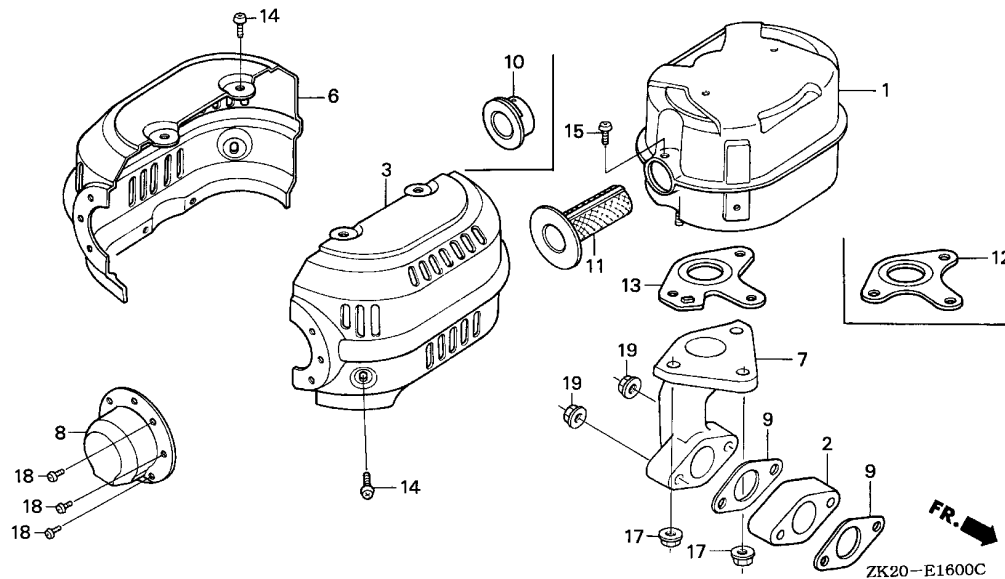

Ref. No.	L.O.N.	(Relative ref. Number) Description	F.R.T.
1	3131C5	MUFFLER, EXHAUST	0.2
3	3131H0	PROTECTOR, EXHAUST MUFFLER :FRONT	0.2
6	3131D3	PROTECTOR, EXHAUST MUFFLER :REAR	0.2
7	3131C9	PIPE, EXHAUST	0.2
9	3131B5	GASKET, EXHAUST PIPE	0.2
		.NOTE: Same time for two units	
11	3131A1	ARRESTER, SPARK	0.2
13	3131B4	GASKET, EXHAUST MUFFLER	0.2

Ref. No.	Part No.	Description	Reqd. QTY			Serial No.	Parts catalogue code
			(1)	(2)	(3)		
1	18310-ZE2-013	MUFFLER COMP.	1	-	-	QAB2,QAB2/A,WMK	
			(1)	-	-	LD,QD,RD,SD	
			-	(1)	-		
			1	-	-	LM9,PMT2,PMT2/A,WKA	
18310-ZE2-822	MUFFLER COMP. (SILENT)	(1)	-	-	LD,QAB2,QD,RD,SD		
		-	(1)	-			
		1	-	-	LM9		
		(1)	-	-			
2	18313-ZE2-U50	SPACER, EX. PIPE (MAMETORA) -	1	-	-	LM9	
			-	(1)	-		
3	18320-ZE2-G30	PROTECTOR, R. MUFFLER (ALUMINIZED)	(1)	-	-	LD,QD,RD,SD	
			-	(1)	-		
			1	-	-	3217995 LM9	
			(1)	(1)	-	3217995 LD,L1,P1,QD,Q1,RD,R1,SD,S1,V1,W1	
18320-ZE2-P30	PROTECTOR, R. MUFFLER (STD.)	1	-	-	QAB2,QAB2/A,WMK		
		1	(1)	-	L1/A,PMT2,PMT2/A,Q1/A,R1/A,S1/A,WKA,W1/A		
18320-ZE2-P50	PROTECTOR, R. MUFFLER (SILENT)	1	-	-	LM9		
		(1)	(1)	-	3217996 LD,L1,P1,QD,Q1,RD,R1,SD,S1,V1,W1		
6	18325-ZE2-G30	PROTECTOR, L. MUFFLER (ALUMINIZED)	(1)	-	-	LD,QD,RD,SD	
			-	(1)	-		
			1	-	-	3217995 LM9	
			(1)	(1)	-	3217995 LD,L1,P1,QD,Q1,RD,R1,SD,S1,V1,W1	
18325-ZE2-P30	PROTECTOR, L. MUFFLER (STD.)	1	-	-	QAB2,QAB2/A,WMK		
		1	(1)	-	L1/A,PMT2,PMT2/A,Q1/A,R1/A,S1/A,WKA,W1/A		
18325-ZE2-P50	PROTECTOR, L. MUFFLER (SILENT)	1	-	-	LM9		
		(1)	(1)	-	3217996 LD,L1,P1,QD,Q1,RD,R1,SD,S1,V1,W1		
7	18330-ZE2-000	PIPE, EX.	1	-	-	LM9,PMT2,PMT2/A,QAB2,QAB2/A,WKA,WMK	
			(1)	-	-	LD,QD,RD,SD	
			-	(1)	-		
			1	-	-		
8	18331-ZE2-810	CAP, MUFFLER	1	-	-	QAB2,QAB2/A	
			-	(1)	-		



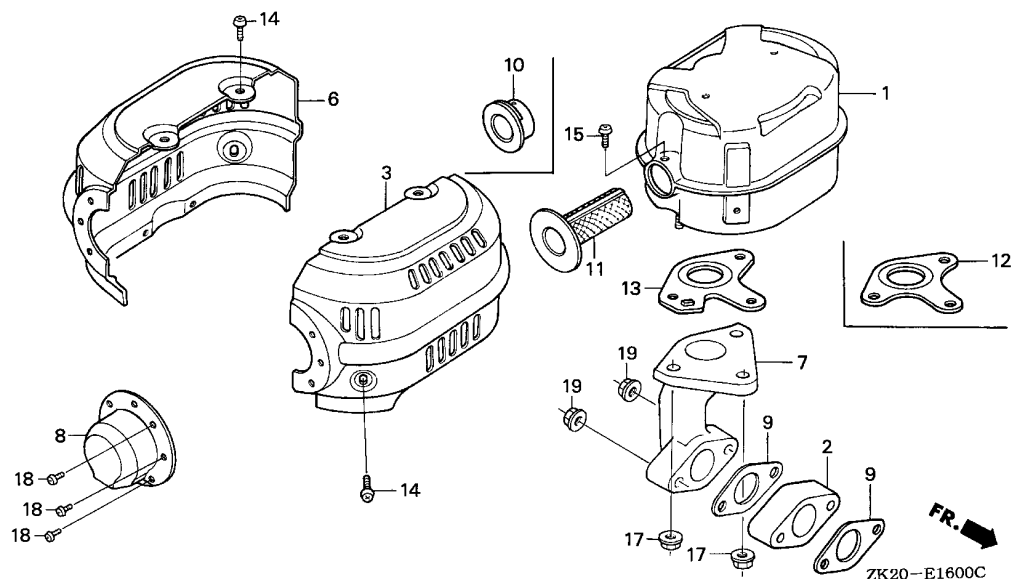

Ref. No.	Part No.	Description	Reqd. QTY			Serial No.	Parts catalogue code
			(1)	(2)	(3)		
(8)	18522-ZE2-U50	GUIDE, MUFFLER (MAMETORA) ...	1	-	-	LM9	
9	18333-ZE3-800	GASKET, EX. PIPE	1	-	-	PMT2,PMT2/A,QAB2,QAB2/A,WKA,WMK	
			2	-	-	LM9	
			(1)	-	-	LD,QD,RD,SD	
10	18336-ZE2-000	FLANGE COMP., BAFFLE	-	(1)	-		
			1	-	-	LM9,PMT2,PMT2/A,WKA	
			(1)	-	-	LD,QD,RD,SD	
			-	(1)	-		
11	18355-ZE2-010	ARRESTER, SPARK	1	-	-	QAB2,QAB2/A,WMK	
			(1)	-	-	LD,QD,RD,SD	
			-	(1)	-		
12	18381-ZE2-800	GASKET, MUFFLER	1	-	-	LM9,PMT2,PMT2/A,WKA	
			(1)	-	-	LD,QD,RD,SD	
			-	(1)	-		
13	18381-ZE2-W10	GASKET, MUFFLER (ARRESTER) ..	1	-	-	QAB2,QAB2/A,WMK	
			(1)	-	-	LD,QD,RD,SD	
			-	(1)	-		
14	90050-ZE1-000	SCREW, TAPPING, 5X8	6	-	-	QAB2,QAB2/A,WMK	
			6	-	-	3217995 LM9	
			(6)	(6)	-	3217995 LD,L1,P1,QD,Q1,RD,R1,SD,S1,V1,W1	
	90050-ZE3-H00	6	(6)	-	L1/A,PMT2,PMT2/A,Q1/A,R1/A,S1/A,WKA,W1/A	
			6	-	-	LM9	
			(6)	(6)	-	3217996 LD,L1,P1,QD,Q1,RD,R1,SD,S1,V1,W1	
15	90050-ZE1-000	SCREW, TAPPING, 5X8	1	-	-	QAB2,QAB2/A,WMK	
			(1)	-	-	LD,QD,RD,SD	
			-	(1)	-		

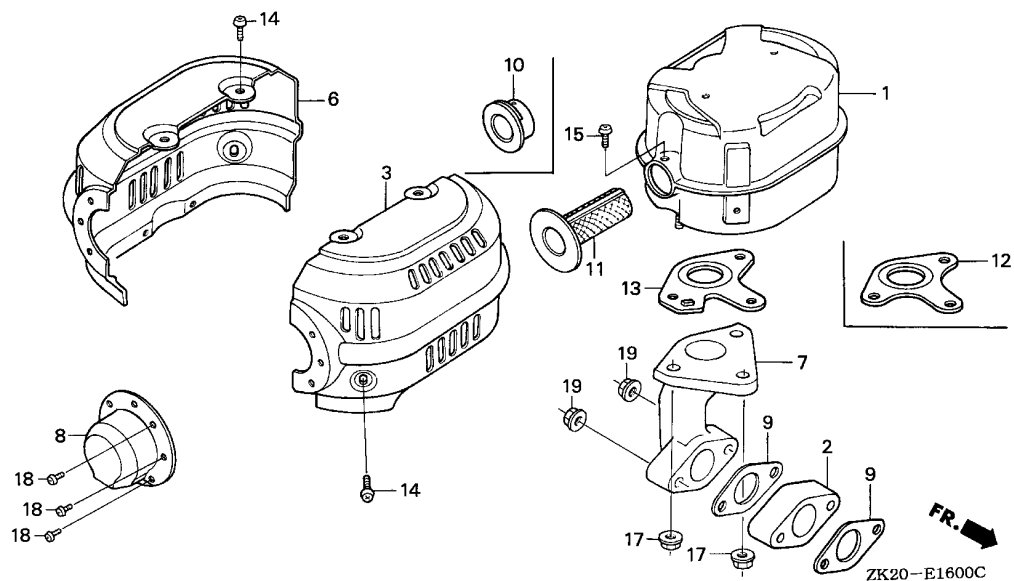

Ref. No.	Part No.	Description	Reqd. QTY			Serial No.	Parts catalogue code
			GX240K1	(1)	(2)		
15)	90055-ZE1-000	SCREW, TAPPING, 4X6	1	-	-	LM9,PMT2,PMT2/A,WKA	
			(1)	-	-	LD,QD,RD,SD	
			-	(1)	-		
17	94050-08000	NUT, FLANGE, 8MM	3	-	-	LM9,PMT2,PMT2/A,QAB2,QAB2/A,WKA,WMK	
			(3)	-	-	LD,QD,RD,SD	
			-	(3)	-		
18	90055-ZE1-000	SCREW, TAPPING, 4X6	3	-	-	LM9,QAB2,QAB2/A	
19	94050-08000	NUT, FLANGE, 8MM	2	-	-	LM9,PMT2,PMT2/A,QAB2,QAB2/A,WKA,WMK	
			(2)	-	-	LD,QD,RD,SD	
			-	(2)	-		



E-16-1

MUFFLER(2)

M 5

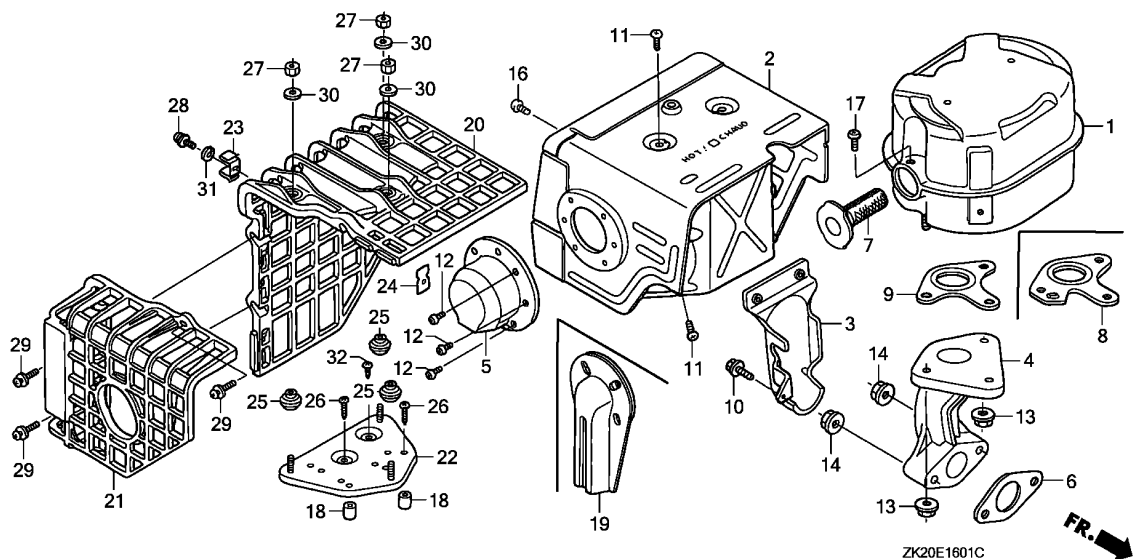

Ref. No.	L.O.N.	(Relative ref. Number) Description	F.R.T.
1	3131C5	MUFFLER, EXHAUST	0.2
2	3131D6	PROTECTOR, EXHAUST MUFFLER ...	0.2
4	3131C9	PIPE, EXHAUST	0.2
6	3131B5	GASKET, EXHAUST PIPE	0.2
7	3131A1	ARRESTER, SPARK	0.2
9	3131B4	GASKET, EXHAUST MUFFLER	0.2
20	3131A7	COVER, EXHAUST MUFFLER	0.1
21	3131A6	COVER, EXHAUST MUFFLER :REAR ..	0.1
22	3131A2	BASE, EXHAUST MUFFLER COVER ..	0.2

Ref. No.	Part No.	Description	Reqd. QTY			Serial No.	Parts catalogue code
			(1)	(2)	(3)		
1	18310-ZE2-W00	MUFFLER COMP.	1	-	-	-----	ED3,ED4,ED4/A,ED5,ED5/A,EN,ET,ETS,ETX,HA,HAQ,HA2,HA2/A,HH,HHQ4,HHQ4/A,HTX,LD,LDB1,LDB3,LH,LH/A,LHE,LHE4,LHE4/A,LHZ,LJ,LJ/A,LJG,LJG/A,LJS,LJS/A,LK,LP,LP/A,LSS4,LSS5,LSS5/A,LT,LT/A,LW,PA,PAE,PA2,PA2/A,QA,QAE,QAE2,QAE2/A,QAG,QAG/A,QAG2,QAG2/A,QAQ,QAQ4,QAR2,QAR2/A,QA2,QA2/A,QC12,QC12/A,QD,QD/A,QDA,QH,QH/A,QHB2,QHC,QHE,QHP1,QHP1/A,QHQ4,QHQ4/A,QHZ,QKA2,QMH,QMH/A,QMX2,QP,QP/A,QT,QT/A,QTC2,QTC2/A,QW24,RA,RA2,RA2/A,RD,RD/A,RH,RHE,RHE4,RHQ4,RHQ4/A,RJ,RJ/A,RSC2,RSS1,RSS1/A,SD,SD/A,SDB1,SDB3,SDB3/A,SH,SHE,SHEZ,SHW,SHW/A,SJ,SJ/A,SJC,SJC1,SJC1/A,SJC5,SJC5/A,SJG,SJG/A,SK,SMX2,SMX2/A,SNR,SNR/A,STP,STP/A,STQ,STQ/A,SW,SWE,VA,VAH1,VA2,VA2/A,VDG2,VDG2/A,VH,VH/A,VH12,VH12/A,VTA,VTA2,VTA2/A,WH,WJ,WJ/A,WKD6,WKD6/A,WKT2,WKT2/A,WKT4,WKT4/A
2	18320-ZE2-W01	PROTECTOR COMP., MUFFLER (STD.)	1	(1)	-	-----	ED3,ED4,ED4/A,ED5,ED5/A,EN,ET,ETS,ETX,HA,HAQ,HA2,HA2/A,HH,HHQ4,HHQ4/A,HTX,LD,LDB1,LDB3,LH,LH/A,LHE,LHE4,LHE4/A,LHZ,LJ,LJ/A,LJG,LJG/A,LJS,LJS/A,LK,LP,LP/A,LSS4,LSS5,LSS5/A,LT,LT/A,LW,PA,PAE,PA2,PA2/A,QA,QAE,QAE2,QAE2/A,QAG,QAG/A,QAG2,QAG2/A,QAQ,QAQ4,QAR2,QAR2/A,QA2,QA2/A,QC12,QC12/A,QD,QD/A,QDA,QH,QH/A,QHB2,QHC,QHE,QHP1,QHP1/A,QHQ4,QHQ4/A,QHZ,QKA2,QMH,QMH/A,QMX2,QP,QP/A,QT,QT/A,QTC2,QTC2/A,QW24,RA,RA2,RA2/A,RD,RD/A,RH,RHE,RHE4,RHQ4,RHQ4/A,RJ,RJ/A,RSC2,RSS1,RSS1/A,SD,SD/A,SDB1,SDB3,SDB3/A,SH,SHE,SHEZ,SHW,SHW/A,SJ,SJ/A,SJC,SJC1,SJC1/A,SJC5,SJC5/A,SJG,SJG/A,SK,SMX2,SMX2/A,SNR,SNR/A,STP,STP/A,STQ,STQ/A,SW,SWE,VA,VAH1,VA2,VA2/A,VDG2,VDG2/A,VH,VH/A,VH12,VH12/A,VTA,VTA2,VTA2/A,WH,WJ,WJ/A,WKD6,WKD6/A,WKT2,WKT2/A,WKT4,WKT4/A

2

Ref. No.	Part No.	Description	Reqd. QTY			Serial No.	Parts catalogue code
			(1)	(2)	(3)		
3	18323-ZE2-W00	PROTECTOR, EX. PIPE	1	-	-	HA,HAQ,HA2,HA2/A,LJ,LJ/A,LJG,LJG/A,LJS,LJS/A,LK,LSS4,LSS5,LSS5/A,LT,LT/A,PA,PAE,PA2,PA2/A,QA,QAE,QAE2,QAE2/A,QAG,QAG/A,QAG2,QAG2/A,QAQ,QAQ4,QAR2,QAR2/A,QA2,QA2/A,QC12,QC12/A,QKA2,QW24,RA,RA2,RA2/A,RJ,RJ/A,RSC2,RSS1,RSS1/A,SJ,SJ/A,SJC,SJC1,SJC1/A,SJC5,SJC5/A,SJG,SJG/A,SK,SNR,SNR/A,VA,VAH1,VA2,VA2/A,VDG2,VDG2/A,VH12,VH12/A,VTA,VTA2,VTA2/A,WJ,WJ/A	
4	18330-ZE2-W00	PIPE, EX.	1	(1)	-	ED3,ED4,ED4/A,ED5,ED5/A,EN,ET,ETS,ETX,HA,HAQ,HA2,HA2/A,HH,HHQ4,HHQ4/A,HTX,LD,LDB1,LDB3,LH,LH/A,LHE,LHE4,LHE4/A,LHZ,LJ,LJ/A,LJG,LJG/A,LJS,LJS/A,LK,LP,LP/A,LSS4,LSS5,LSS5/A,LT,LT/A,LW,PA,PAE,PA2,PA2/A,QA,QAE,QAE2,QAE2/A,QAG,QAG/A,QAG2,QAG2/A,QAQ,QAQ4,QAR2,QAR2/A,QA2,QA2/A,QC12,QC12/A,QD,QD/A,QDA,QH,QH/A,QHB2,QHC,QHE,QHP1,QHP1/A,QHQ4,QHQ4/A,QHZ,QKA2,QMH,QMH/A,QMX2,QP,QP/A,QT,QT/A,QTC2,QTC2/A,QW24,RA,RA2,RA2/A,RD,RD/A,RH,RHE,RHE4,RHQ4,RHQ4/A,RJ,RJ/A,RSC2,RSS1,RSS1/A,SD,SD/A,SDB1,SDB3,SDB3/A,SH,SHE,SHEZ,SHW,SHW/A,SJ,SJ/A,SJC,SJC1,SJC1/A,SJC5,SJC5/A,SJG,SJG/A,SK,SMX2,SMX2/A,SNR,SNR/A,STP,STP/A,STQ,STQ/A,SW,SWE,VA,VAH1,VA2,VA2/A,VDG2,VDG2/A,VH,VH/A,VH12,VH12/A,VTA,VTA2,VTA2/A,WH,WJ,WJ/A,WKD6,WKD6/A,WKT2,WKT2/A,WKT4,WKT4/A	
5	18331-ZE2-810	CAP, MUFFLER	1	(1)	-	HA,HAQ,HA2,HA2/A,LJS,LJS/A,LP,LP/A,LSS4,LT,LT/A,LW,PA,PAE,PA2,PA2/A,QA,QAE,QAE2,QAE2/A,QAG2,QAG2/A,QAQ,QAQ4,QAR2,QAR2/A,QA2,QA2/A,QC12,QC12/A,QKA2,QMH,QMH/A,QP,QP/A,QT,QT/A,QTC2,QTC2/A,QW24,RA,RA2,RA2/A,SJC,SJC1,SJC1/A,SJC5,SJC5/A,STP,STP/A,STQ,STQ/A,SW,SWE,VA,VA2,VA2/A,VDG2,VDG2/A,VTA,VTA2,VTA2/A	
6	18333-ZE3-800	GASKET, EX. PIPE	1	(1)	-	ED3,ED4,ED4/A,ED5,ED5/A,EN,ET,ETS,ETX,HA,HAQ,HA2,HA2/A,HH,HHQ4,HHQ4/A,HTX,LD,LDB1,LDB3,LH,LH/A,LHE,LHE4,LHE4/A,LHZ,LJ,LJ/A,LJG,LJG/A,LJS,LJS/A,LK,LP,LP/A,LSS4,LSS5,LSS5/A,LT,LT/A,LW,PA,PAE,PA2,PA2/A,QA,QAE,QAE2,QAE2/A,QAG,QAG/A,QAG2,QAG2/A,QAQ,QAQ4,QAR2,QAR2/A,QA2,QA2/A,QC12,QC12/A,QD,QD/A,QDA,QH,QH/A,QHB2,QHC,QHE,QHP1,QHP1/A,QHQ4,QHQ4/A,QHZ,QKA2,QMH,QMH/A,QMX2,QP,QP/A,QT,QT/A,QTC2,QTC2/A,QW24,RA,RA2,RA2/A,RD,RD/A,RH,RHE,RHE4,RHQ4,RHQ4/A,RJ,RJ/A,RSC2,RSS1,RSS1/A,SD,SD/A,SDB1,SDB3,SDB3/A,SH,SHE,SHEZ,SHW,SHW/A,SJ,SJ/A,SJC,SJC1,SJC1/A,SJC5,SJC5/A,SJG,SJG/A,SK,SMX2,SMX2/A,SNR,SNR/A,STP,STP/A,STQ,STQ/A,SW,SWE,VA,VAH1,VA2,VA2/A,VDG2,VDG2/A,VH,VH/A,VH12,VH12/A,VTA,VTA2,VTA2/A,WH,WJ,WJ/A,WKD6,WKD6/A,WKT2,WKT2/A,WKT4,WKT4/A	
7	18355-ZE2-010	ARRESTER, SPARK	1	(1)	-	ED5,ED5/A,LJS,LJS/A,PAE,QA,QAE,QAE2,QAE2/A,QAG2,QAG2/A,QAQ,QAQ4,QAR2,QAR2/A,QA2,QA2/A,QC12,QC12/A,QHB2,QKA2,QMX2,QTC2,QTC2/A,QW24,SMX2,SMX2/A,STP,STP/A,STQ,STQ/A,VA,VAH1,VA2,VA2/A,VDG2,VDG2/A,VH12,VH12/A,VTA,VTA2,VTA2/A,WKD6,WKD6/A,WKT2,WKT2/A,WKT4,WKT4/A	
8	18381-ZE2-W10	GASKET, MUFFLER (ARRESTER) ..	1	(1)	-	HA,HAQ,HA2,HA2/A,PA,PA2,PA2/A,RA,RA2,RA2/A,RSC2	
			(1)	(1)	-	ED5,ED5/A,LJS,LJS/A,PAE,QA,QAE,QAE2,QAE2/A,QAG2,QAG2/A,QAQ,QAQ4,QAR2,QAR2/A,QA2,QA2/A,QC12,QC12/A,QHB2,QKA2,QMX2,QTC2,QTC2/A,QW24,SMX2,SMX2/A,STP,STP/A,STQ,STQ/A,VA,VAH1,VA2,VA2/A,VDG2,VDG2/A,VH12,VH12/A,VTA,VTA2,VTA2/A,WKD6,WKD6/A,WKT2,WKT2/A,WKT4,WKT4/A	
			(1)	(1)	-	HA,HAQ,HA2,HA2/A,PA,PA2,PA2/A,RA,RA2,RA2/A,RSC2	



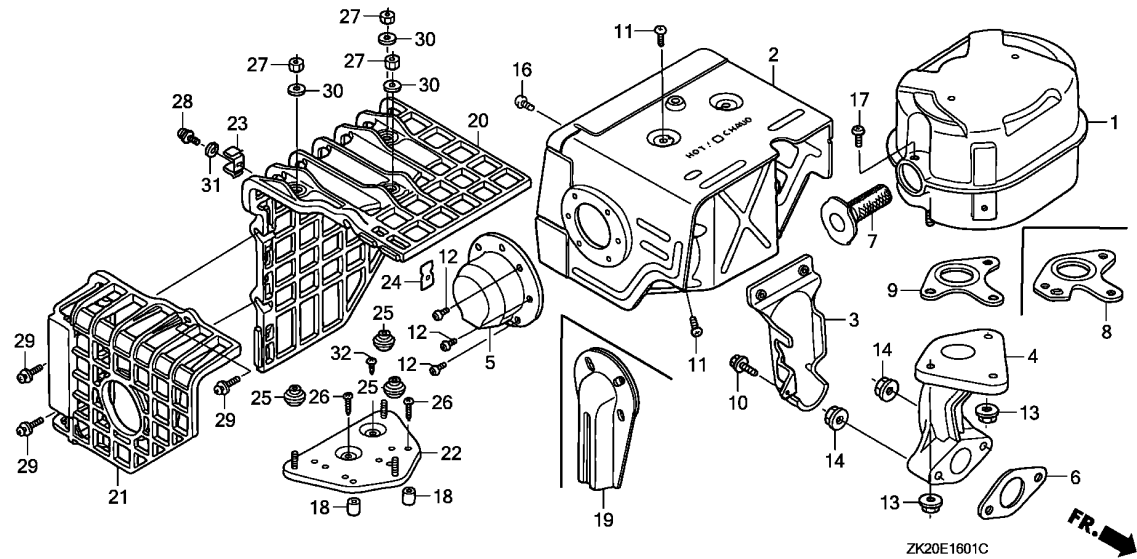

Ref. No.	Part No.	Description	Reqd. QTY			Serial No.	Parts catalogue code
			(1)	(2)	(3)		
9	18381-ZE2-800	GASKET, MUFFLER	1	-	-	-----	ED3,ED4,ED4/A,EN,ET,ETS,ETX,HA,HAQ,HA2,HA2/A,HH,HHQ4,HHQ4/A,HTX LD,LDB1,LDB3,LH,LH/A,LHE,LHE4,LHE4/A,LHZ,LJ,LJ/A,LJG,LJG/A,LK,LP LP/A,LSS4,LSS5,LSS5/A,LT,LT/A,LW,PA,PA2,PA2/A,QAG,QAG/A,QD,QD/A QDA,QH,QH/A,QHC,QHE,QHP1,QHP1/A,QHQ4,QHQ4/A,QHZ,QMH,QMH/A,QP,QP/A QT,QT/A,RA,RA2,RA2/A,RD,RD/A,RH,RHE,RHE4,RHQ4,RHQ4/A,RJ,RJ/A,RSC2 RSS1,RSS1/A,SD,SD/A,SDB1,SDB3,SDB3/A,SH,SHE,SHEZ,SHW,SHW/A,SJ SJ/A,SJC,SJC1,SJC1/A,SJC5,SJC5/A,SJG,SJG/A,SK,SNR,SNR/A,SW,SWE,VH VH/A,WH,WJ,WJ/A
10	90013-883-000	BOLT, FLANGE, 6X12(CT200) ...	1	(1)	-	-----	HA,HAQ,HA2,HA2/A,LJ,LJ/A,LJG,LJG/A,LJS,LJS/A,LK,LSS4,LSS5,LSS5/A LT,LT/A,PA,PAE,PA2,PA2/A,QA,QA2,QA2/A,QAG,QAG/A,QAG2,QAG2/A QAQ,QAQ4,QAR2,QAR2/A,QA2,QA2/A,QC12,QC12/A,QKA2,QW24,RA,RA2,RA2/A RJ,RJ/A,RSC2,RSS1,RSS1/A,SJ,SJ/A,SJC,SJC1,SJC1/A,SJC5,SJC5/A,SJG SJG/A,SK,SNR,SNR/A,VA,VAH1,VA2,VA2/A,VDG2,VDG2/A,VH12,VH12/A,VTA VTA2,VTA2/A,WJ,WJ/A
			-	(1)	-	-----	

Ref. No.	Part No.	Description	Reqd. QTY			Serial No.	Parts catalogue code
			GX240K1	(1)	(2)		
11	90050-ZE1-000	SCREW, TAPPING, 5X8	4	-	-	-----	ED3,ED4,ED4/A,ED5,ED5/A,EN,ET,ETS,ETX,HA,HAQ,HA2,HA2/A,HH,HHQ4,HHQ4/A,HTX,LD,LDB1,LDB3,LH,LH/A,LHE,LHE4,LHE4/A,LHZ,LJ,LJ/A,LJG,LJG/A,LJS,LJS/A,LK,LP,LP/A,LSS4,LSS5,LSS5/A,LT,LT/A,LW,PA,PAE,PA2,PA2/A,QA,QAE,QAE2,QAE2/A,QAG,QAG/A,QAG2,QAG2/A,QAQ,QAQ4,QAR2,QAR2/A,QA2,QA2/A,QC12,QC12/A,QD,QD/A,QDA,QH,QH/A,QHB2,QHC,QHE,QHP1,QHP1/A,QHQ4,QHQ4/A,QHZ,QKA2,QMH,QMH/A,QMX2,QP,QP/A,QT,QT/A,QTC2,QTC2/A,QW24,RA,RA2,RA2/A,RD,RD/A,RH,RHE,RHE4,RHQ4,RHQ4/A,RJ,RJ/A,RSC2,RSS1,RSS1/A,SD,SD/A,SDB1,SDB3,SDB3/A,SH,SHE,SHEZ,SHW,SHW/A,SJ,SJ/A,SJC,SJC1,SJC1/A,SJC5,SJC5/A,SJG,SJG/A,SK,SMX2,SMX2/A,SNR,SNR/A,STP,STP/A,STQ,STQ/A,SW,SWE,VA,VAH1,VA2,VA2/A,VDG2,VDG2/A,VH,VH/A,VH12,VH12/A,VTA,VTA2,VTA2/A,WH,WJ,WJ/A,WKD6,WKD6/A,WKT2,WKT2/A,WKT4,WKT4/A
12	90055-ZE1-000	SCREW, TAPPING, 4X6	3	(4)	-	-----	HA,HAQ,HA2,HA2/A,LJS,LJS/A,LP,LP/A,LSS4,LT,LT/A,LW,PA,PAE,PA2,PA2/A,QA,QAE,QAE2,QAE2/A,QAG,QAG2/A,QAQ,QAQ4,QAR2,QAR2/A,QA2,QA2/A,QC12,QC12/A,QKA2,QMH,QMH/A,QP,QP/A,QT,QT/A,QTC2,QTC2/A,QW24,RA,RA2,RA2/A,SJC,SJC1,SJC1/A,SJC5,SJC5/A,STP,STP/A,STQ,STQ/A,SW,SWE,VA,VA2,VA2/A,VDG2,VDG2/A,VTA,VTA2,VTA2/A
13	94050-08000	NUT, FLANGE, 8MM	3	(3)	-	-----	ED3,ED4,ED4/A,ED5,ED5/A,EN,ET,ETS,ETX,HA,HAQ,HA2,HA2/A,HH,HHQ4,HHQ4/A,HTX,LD,LDB1,LDB3,LH,LH/A,LHE,LHE4,LHE4/A,LHZ,LJ,LJ/A,LJG,LJG/A,LJS,LJS/A,LK,LP,LP/A,LSS4,LSS5,LSS5/A,LT,LT/A,LW,PA,PAE,PA2,PA2/A,QA,QAE,QAE2,QAE2/A,QAG,QAG/A,QAG2,QAG2/A,QAQ,QAQ4,QAR2,QAR2/A,QA2,QA2/A,QC12,QC12/A,QD,QD/A,QDA,QH,QH/A,QHB2,QHC,QHE,QHP1,QHP1/A,QHQ4,QHQ4/A,QHZ,QKA2,QMH,QMH/A,QMX2,QP,QP/A,QT,QT/A,QTC2,QTC2/A,QW24,RA,RA2,RA2/A,RD,RD/A,RH,RHE,RHE4,RHQ4,RHQ4/A,RJ,RJ/A,RSC2,RSS1,RSS1/A,SD,SD/A,SDB1,SDB3,SDB3/A,SH,SHE,SHEZ,SHW,SHW/A,SJ,SJ/A,SJC,SJC1,SJC1/A,SJC5,SJC5/A,SJG,SJG/A,SK,SMX2,SMX2/A,SNR,SNR/A,STP,STP/A,STQ,STQ/A,SW,SWE,VA,VAH1,VA2,VA2/A,VDG2,VDG2/A,VH,VH/A,VH12,VH12/A,VTA,VTA2,VTA2/A,WH,WJ,WJ/A,WKD6,WKD6/A,WKT2,WKT2/A,WKT4,WKT4/A
14	94050-08000	NUT, FLANGE, 8MM	2	(3)	-	-----	ED3,ED4,ED4/A,ED5,ED5/A,EN,ET,ETS,ETX,HA,HAQ,HA2,HA2/A,HH,HHQ4,HHQ4/A,HTX,LD,LDB1,LDB3,LH,LH/A,LHE,LHE4,LHE4/A,LHZ,LJ,LJ/A,LJG,LJG/A,LJS,LJS/A,LK,LP,LP/A,LSS4,LSS5,LSS5/A,LT,LT/A,LW,PA,PAE,PA2,PA2/A,QA,QAE,QAE2,QAE2/A,QAG,QAG/A,QAG2,QAG2/A,QAQ,QAQ4,QAR2,QAR2/A,QA2,QA2/A,QC12,QC12/A,QD,QD/A,QDA,QH,QH/A,QHB2,QHC,QHE,QHP1,QHP1/A,QHQ4,QHQ4/A,QHZ,QKA2,QMH,QMH/A,QMX2,QP,QP/A,QT,QT/A,QTC2,QTC2/A,QW24,RA,RA2,RA2/A,RD,RD/A,RH,RHE,RHE4,RHQ4,RHQ4/A,RJ,RJ/A,RSC2,RSS1,RSS1/A,SD,SD/A,SDB1,SDB3,SDB3/A,SH,SHE,SHEZ,SHW,SHW/A,SJ,SJ/A,SJC,SJC1,SJC1/A,SJC5,SJC5/A,SJG,SJG/A,SK,SMX2,SMX2/A,SNR,SNR/A,STP,STP/A,STQ,STQ/A,SW,SWE,VA,VAH1,VA2,VA2/A,VDG2,VDG2/A,VH,VH/A,VH12,VH12/A,VTA,VTA2,VTA2/A,WH,WJ,WJ/A,WKD6,WKD6/A,WKT2,WKT2/A,WKT4,WKT4/A
16	90050-ZE1-000	SCREW, TAPPING, 5X8	2	(2)	-	-----	HA,HAQ,HA2,HA2/A,LJ,LJ/A,LJG,LJG/A,LJS,LJS/A,LK,LSS4,LSS5,LSS5/A,LT,LT/A,PA,PAE,PA2,PA2/A,QA,QAE,QAE2,QAE2/A,QAG,QAG/A,QAG2,QAG2/A,QAQ,QAQ4,QAR2,QAR2/A,QA2,QA2/A,QC12,QC12/A,QHB2,QKA2,QW24,RA,RA2,RA2/A,RJ,RJ/A,RSC2,RSS1,RSS1/A,SJ,SJ/A,SJC,SJC1/A,SJC5,SJC5/A,SJG,SJG/A,SK,SNR,SNR/A,VA,VAH1,VA2,VA2/A,VDG2,VDG2/A,VH12,VH12/A,VTA,VTA2,VTA2/A,WJ,WJ/A
17	90050-ZE1-000	SCREW, TAPPING, 5X8	1	(2)	-	-----	ED5,ED5/A,LJS,LJS/A,QAE2,QAE2/A,QAG2,QAG2/A,QAQ,QAQ4,QAR2,QAR2/A,QA2,QA2/A,QC12,QC12/A,QHB2,QKA2,QMX2,QTC2,QTC2/A,QW24,SMX2,SMX2/A,STP,STP/A,STQ,STQ/A,VA2,VA2/A,VDG2,VDG2/A,VH12,VH12/A,VTA2,VTA2/A,WKD6,WKD6/A,WKT2,WKT2/A,WKT4,WKT4/A
			-	(1)	-	-----	



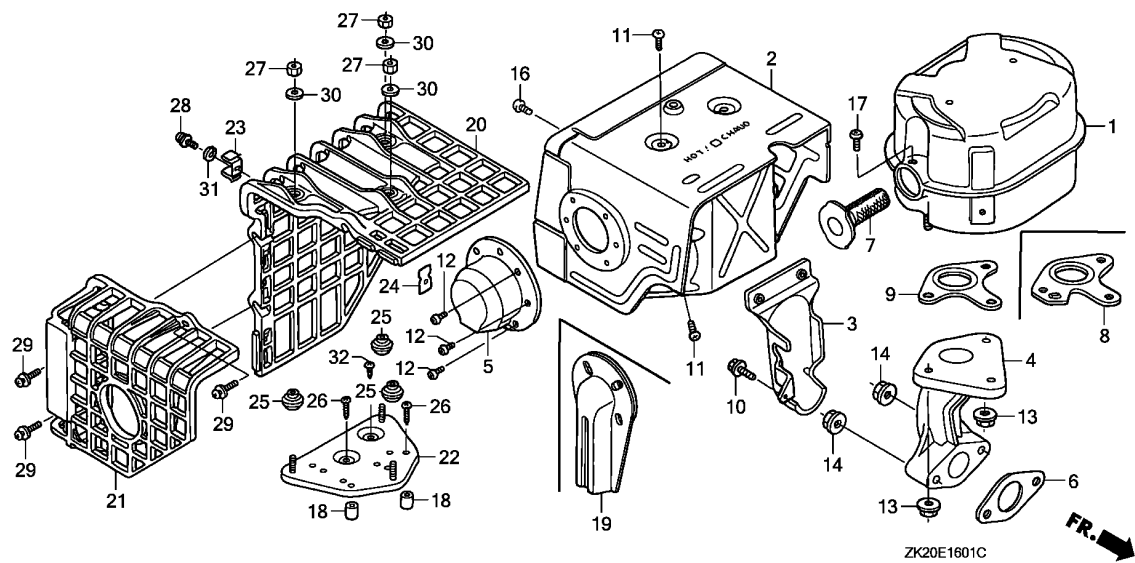

Ref. No.	Part No.	Description	Reqd. QTY			Serial No.	Parts catalogue code
			(1)	(2)	(3)		
17)	90055-ZE1-000	SCREW, TAPPING, 4X6	1	-	-	PAE,QA,QAE,VA,VAH1,VTA	
18	17233-896-701	COLLAR, AIR CLEANER CASE	(1)	-	-	HA,HAQ,HA2,HA2/A,PA,PA2,PA2/A,RA,RA2,RA2/A,RSC2	
19	18430-ZK9-W50	DEFLECTOR COMP., MUFFLER	(1)	-	-	HHQ4,HHQ4/A,LHE4,LHE4/A,QAQ4,QHB2,QHQ4,QHQ4/A,QW24,RHE4,RHQ4	
20	18433-ZK9-W40	COVER COMP., MUFFLER	(1)	-	-	RHQ4/A,WKT4,WKT4/A	
21	18434-ZK9-W40	COVER COMP., MUFFLER RR.	(1)	-	-	QAQ4	
22	18436-ZH8-W40	BASE COMP., MUFFLER COVER	(1)	-	-	HHQ4,HHQ4/A,LHE4,LHE4/A,QAQ4,QHB2,QHQ4,QHQ4/A,QW24,RHE4,RHQ4	
23	18437-ZF6-W40	STAY, MUFFLER COVER	(1)	-	-	RHQ4/A,WKT4,WKT4/A	
24	18438-ZF6-W40	PLATE, SET	(1)	-	-	HHQ4,HHQ4/A,LHE4,LHE4/A,QAQ4,QHB2,QHQ4,QHQ4/A,QW24,RHE4,RHQ4	
25	18466-ZH8-W40	SPACER, MUFFLER COVER	(3)	-	-	RHQ4/A,WKT4,WKT4/A	
26	90050-ZH8-W40	SCREW, TAPPING, 5X25	(2)	-	-	HHQ4,HHQ4/A,LHE4,LHE4/A,QAQ4,QHB2,QHQ4,QHQ4/A,QW24,RHE4,RHQ4	
27	90302-KF9-900	NUT, HEX., 5MM	(3)	-	-	RHQ4/A,WKT4,WKT4/A	
28	93891-05012-00	SCREW-WASHER, 5X12	(1)	-	-	HHQ4,HHQ4/A,LHE4,LHE4/A,QAQ4,QHB2,QHQ4,QHQ4/A,QW24,RHE4,RHQ4	
29	93891-06020-07	SCREW-WASHER, 6X20	(3)	-	-	RHQ4/A,WKT4,WKT4/A	
30	94103-05700	WASHER, PLAIN, 5MM	(3)	-	-	HHQ4,HHQ4/A,LHE4,LHE4/A,QAQ4,QHB2,QHQ4,QHQ4/A,QW24,RHE4,RHQ4	
						RHQ4/A,WKT4,WKT4/A	

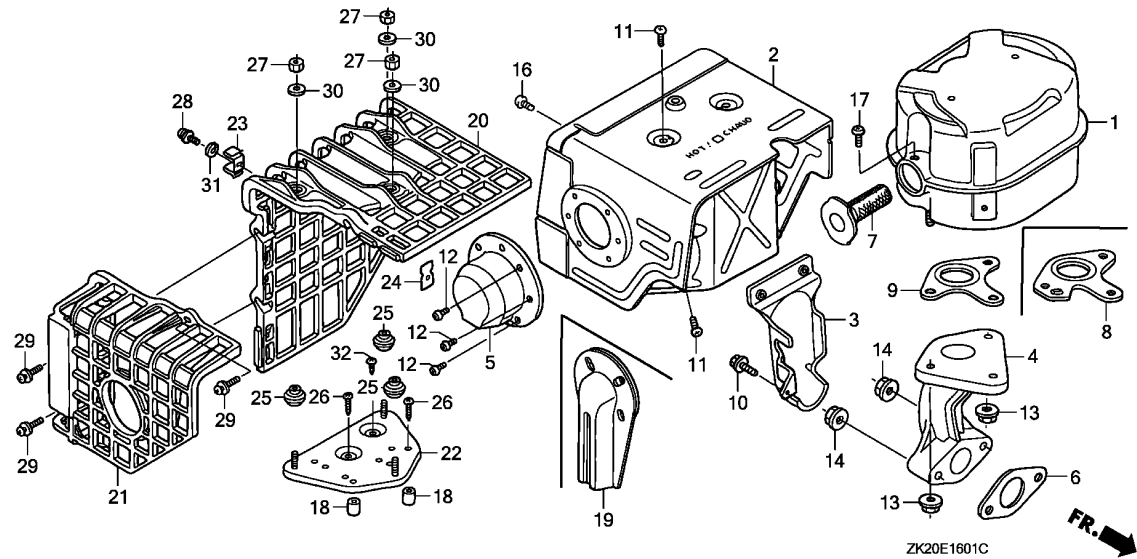

Ref. No.	Part No.	Description	Reqd. QTY			Serial No.	Parts catalogue code
			(1)	(2)	(3)		
			GX240K1				
31	94111-05000	WASHER, SPRING, 5MM	(1)	-	-	-----	HHQ4,HHQ4/A,LHE4,LHE4/A,QAQ4,QHB2,QHQ4,QHQ4/A,QW24,RHE4,RHQ4 RHQ4/A,WKT4,WKT4/A
32	90050-ZE1-000	SCREW, TAPPING, 5X8	(1)	-	-	-----	HHQ4,HHQ4/A,LHE4,LHE4/A,QAQ4,QHB2,QHQ4,QHQ4/A,QW24,RHE4,RHQ4 RHQ4/A,WKT4,WKT4/A



E-16-2

MUFFLER(3)

M11

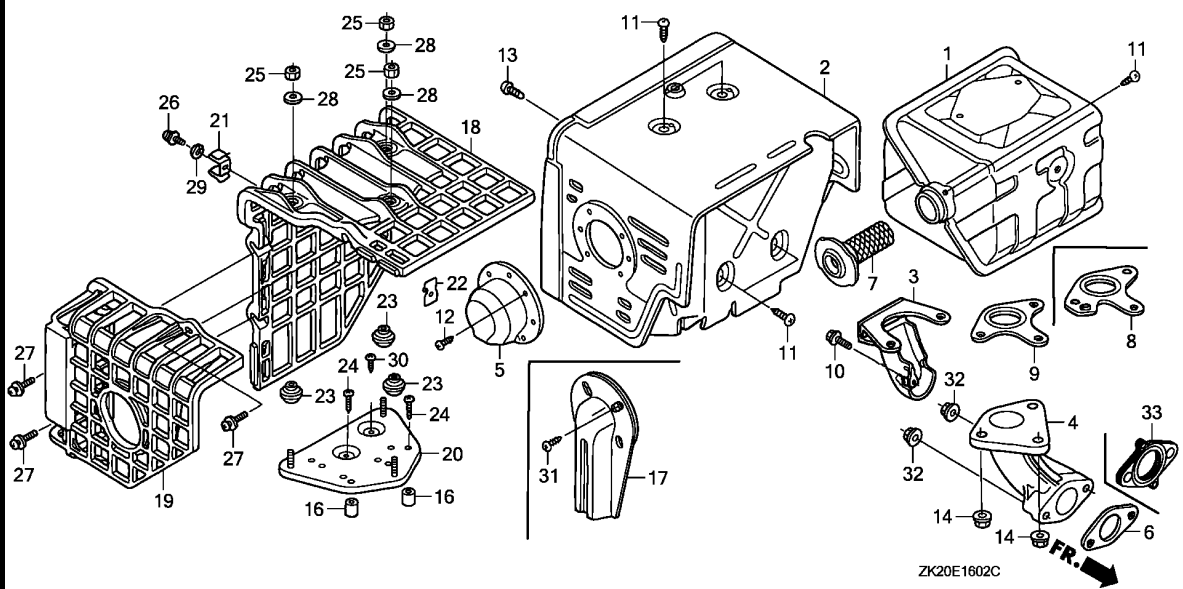

Ref. No.	L.O.N.	(Relative ref. Number) Description	F.R.T.
1	3131C5	MUFFLER, EXHAUST	0.2
2	3131D6	PROTECTOR, EXHAUST MUFFLER ...	0.2
4	3131C9	PIPE, EXHAUST	0.2
6		(33)	
	3131B5	GASKET, EXHAUST PIPE	0.2
7	3131A1	ARRESTER, SPARK	0.2
9		(8)	
	3131B4	GASKET, EXHAUST MUFFLER	0.2
18	3131A7	COVER, EXHAUST MUFFLER	0.1
19	3131A6	COVER, EXHAUST MUFFLER :REAR ..	0.1
20	3131A2	BASE, EXHAUST MUFFLER COVER ..	0.2

Ref. No.	Part No.	Description	Reqd. QTY			Serial No.	Parts catalogue code
			(1)	(2)	(3)		
1	18310-ZE2-W61	MUFFLER COMP. (100DB)	1	-	-	ES, ES1, ES1/A, ES2, HX, HX/A, HXQ4, HXQ4/A, LJG1, LSX, LSX/A, LX, LX/A, LXF, LXQ4, LXQ4/A, LXZ, LX2, LX2/A, PX, PX/A, QE, QE/A, QX, QX/A, QXB, QXB7, QXB7/A, QXC, QXC/A, QXC9, QXC9/A, QXE, QXE/A, QXEB, QXE4, QXE4/A, QXQ4, QXQ4/A, QXU, QXU/A, RTB2, RTB2/A, RX, RX/A, RXQ4, RXQ4/A, SE, SE/A, SNC1, SNE1, SX, SX/A, SXB, SXE, SXEB, SXE4, SXE4/A, SXQ4, SXQ4/A, SXU, SXU/A, VMX, VNG, VWC2, VWC2/A, VX, VX/A, VXB, VXB/A, VXB7, VXB7/A, VXE, VXE/A, VXE, VXE/A, VXEB, VXEB/A, VXQ4, VXQ4/A, VXQ7, VXQ7/A, VXU, VXU/A, VXU1, VXU1/A	
2	18320-ZE2-W61	PROTECTOR COMP., MUFFLER	-	(1)	1	ES, ES1, ES1/A, ES2, HX, HX/A, HXQ4, HXQ4/A, LJG1, LSX, LSX/A, LX, LX/A, LXF, LXQ4, LXQ4/A, LXZ, LX2, LX2/A, PX, PX/A, QE, QE/A, QX, QX/A, QXB, QXB7, QXB7/A, QXC, QXC/A, QXC9, QXC9/A, QXE, QXE/A, QXEB, QXE4, QXE4/A, QXQ4, QXQ4/A, QXU, QXU/A, RTB2, RTB2/A, RX, RX/A, RXQ4, RXQ4/A, SE, SE/A, SNC1, SNE1, SX, SX/A, SXB, SXE, SXEB, SXE4, SXE4/A, SXQ4, SXQ4/A, SXU, SXU/A, VMX, VNG, VWC2, VWC2/A, VX, VX/A, VXB, VXB/A, VXB7, VXB7/A, VXE, VXE/A, VXE, VXE/A, VXEB, VXEB/A, VXQ4, VXQ4/A, VXQ7, VXQ7/A, VXU, VXU/A, VXU1, VXU1/A	
3	18323-ZE2-W60	PROTECTOR, EX. PIPE (100DB) ..	-	(1)	1		
4	18330-ZH9-N00	PIPE, EX.	1	-	-	ES, ES1, ES1/A, ES2, HX, HX/A, HXQ4, HXQ4/A, LJG1, LSX, LSX/A, LX, LX/A, LXF, LXQ4, LXQ4/A, LXZ, LX2, LX2/A, PX, PX/A, QE, QE/A, QX, QX/A, QXB, QXB7, QXB7/A, QXC, QXC/A, QXC9, QXC9/A, QXE, QXE/A, QXEB, QXE4, QXE4/A, QXQ4, QXQ4/A, QXU, QXU/A, RTB2, RTB2/A, RX, RX/A, RXQ4, RXQ4/A, SE, SE/A, SNC1, SNE1, SX, SX/A, SXB, SXE, SXEB, SXE4, SXE4/A, SXQ4, SXQ4/A, SXU, SXU/A, VMX, VNG, VWC2, VWC2/A, VX, VX/A, VXB, VXB/A, VXB7, VXB7/A, VXE, VXE/A, VXE, VXE/A, VXEB, VXEB/A, VXQ4, VXQ4/A, VXQ7, VXQ7/A, VXU, VXU/A, VXU1, VXU1/A	
5	18331-ZE2-810	CAP, MUFFLER	1	-	-	QE, QE/A, RTB2, RTB2/A, SE, SE/A, VMX	

2

Ref. No.	Part No.	Description	Reqd. QTY			Serial No.	Parts catalogue code
			(1)	(2)	(3)		
6	18333-ZE3-800	GASKET, EX. PIPE	1	(1)	-	3486453	ES, ES1, HX, HXQ4, LX, LXQ4, LXZ, LX2, L1, PX, P1, QE, QX, QXB, QXC, QXC9, QXE, QXE4, QXE4/A, QXQ4, Q1, RTB2, RX, RXQ4, R1, SE, SNC1, SNE1, SX, SXB, SXE, SXEB, SXE4, SXQ4, S1, VNG, VWC2, VX, VXB, VXE, VXEB, VXQ4, VXU, V1, W1
	18333-ZK6-Y00	1	(1)	-	3486454	LXZ, L1, P1, QXB, QXE4, QXQ4, R1, SNC1, SNE1, SXB, SXE, SXEB, S1, VNG, V1, W1
			1	-	-	3844352	LJG1, LSX, QXU, SXU, VMX, VXU1
			1	-	-	3486454	3844352 ES, ES1, HX, HXQ4, LX, LXQ4, LX2, PX, QE, QX, QXC, QXC9, QXE, QXE4, QXQ4, RTB2, RX, RXQ4, SE, SX, SXE4, SXQ4, VWC2, VX, VXB, VXE, VXEB, VXQ4, VXU
			-	(1)	-		L1/A, Q1/A, R1/A, S1/A, W1/A
7	18355-ZE2-W00	ARRESTER, SPARK	1	-	-		LJG1, QE, QE/A, QXB, QXB7, QXB7/A, QXE, QXE4, QXQ4, RTB2, RTB2/A, SE, SE/A, SNC1, SXB, SXEB, VNG, VWC2, VWC2/A, VXB, VXB7, VXB7/A, VXEB, VXEB/A
	18355-ZE2-010	-	(1)	-		RTB2, RTB2/A
8	18381-ZE2-W10	GASKET, MUFFLER (ARRESTER) ..	1	-	-		LJG1, QE, QE/A, QXB, QXB7, QXB7/A, QXE, QXE4, QXQ4, RTB2, RTB2/A, SE, SE/A, SNC1, SXB, SXEB, VNG, VWC2, VWC2/A, VXB, VXB7, VXB7/A, VXEB, VXEB/A
			-	(1)	-		
9	18381-ZE2-800	GASKET, MUFFLER	1	-	-		ES, ES1, ES1/A, ES2, HX, HX/A, HXQ4, HXQ4/A, LSX, LSX/A, LX, LX/A, LXF, LXQ4, LXQ4/A, LXZ, LX2, LX2/A, PX, PX/A, QX, QX/A, QXC, QXC/A, QXC9, QXC9/A, QXE, QXE/A, QXE4, QXE4/A, QXQ4, QXQ4/A, QXU, QXU/A, RX, RX/A, RXQ4, RXQ4/A, SNE1, SX, SX/A, SXE, SXE4, SXE4/A, SXQ4, SXQ4/A, SXU, SXU/A, VMX, VX, VX/A, VXE, VXE/A, VXQ4, VXQ4/A, VXQ7, VXQ7/A, VXU, VXU/A, VXU1, VXU1/A
			-	(1)	1		
10	90013-883-000	BOLT, FLANGE, 6X12(CT200) ...	-	(1)	-		
11	90050-ZE1-000	SCREW, TAPPING, 5X8	4	-	-		ES, ES1, ES1/A, ES2, HX, HX/A, HXQ4, HXQ4/A, LSX, LSX/A, LX, LX/A, LXF, LXQ4, LXQ4/A, LXZ, LX2, LX2/A, PX, PX/A, QX, QX/A, QXC, QXC/A, QXC9, QXC9/A, QXE, QXE/A, QXE4, QXE4/A, QXQ4, QXQ4/A, QXU, QXU/A, RX, RX/A, RXQ4, RXQ4/A, SNE1, SX, SX/A, SXE, SXE4, SXE4/A, SXQ4, SXQ4/A, SXU, SXU/A, VMX, VX, VX/A, VXE, VXE/A, VXQ4, VXQ4/A, VXQ7, VXQ7/A, VXU, VXU/A, VXU1, VXU1/A
			5	-	-		LJG1, QE, QE/A, QXB, QXB7, QXB7/A, QXE, QXE4, QXQ4, RTB2, RTB2/A, SE, SE/A, SNC1, SXB, SXEB, VNG, VWC2, VWC2/A, VXB, VXB7, VXB7/A, VXEB, VXEB/A
			-	(5)	4		
12	90055-ZE1-000	SCREW, TAPPING, 4X6	3	-	-		QE, QE/A, RTB2, RTB2/A, SE, SE/A, VMX
			-	(3)	-		
13	93901-360J0	SCREW, TAPPING, 6X10	1	(1)	-	3151974	ES, ES1, HX, LX, LXZ, L1, PX, P1, QE, QX, QXB, QXC, QXE, QXE4, QXE4/A, QXQ4, QXQ4/A, QXU, QXU/A, RX, R1, SE, SX, SXB, SXE, SXEB, S1, VNG, VX, VXB, VXE, VXEB, V1, W1
	90006-ZE2-000	1	(1)	-		ES1/A, ES2, HX/A, HXQ4, HXQ4/A, LJG1, LSX, LSX/A, LX/A, LXF, LXQ4, LXQ4/A, LXZ, LX2/A, L1/A, PX/A, PX/A, QE/A, QX/A, QXB7, QXB7/A, QXC/A, QXC9, QXC9/A, QXE/A, QXE4, QXE4/A, QXQ4, QXQ4/A, QXU, QXU/A, Q1/A, RTB2, RTB2/A, RX/A, RXQ4, RXQ4/A, R1/A, SE/A, SNC1, SNE1, SX/A, SXE4, SXE4/A, SXQ4, SXQ4/A, SXU, SXU/A, S1/A, VMX, VWC2, VWC2/A, VX/A, VXB7, VXB7/A, VXE/A, VXEB/A, VXQ4, VXQ4/A, VXQ7, VXQ7/A, VXU, VXU/A, VXU1, VXU1/A, W1/A
			1	(1)	-	3151975	ES, ES1, HX, LX, LXZ, L1, PX, P1, QE, QX, QXB, QXC, QXE, QXE4, QXE4/A, QXQ4, QXQ4/A, QXU, QXU/A, RX, R1, SE, SX, SXB, SXE, SXEB, S1, VNG, VX, VXB, VXE, VXEB, V1, W1
			-	-	1		
14	94050-08000	NUT, FLANGE, 8MM	3	-	-		ES, ES1, ES1/A, ES2, HX, HX/A, HXQ4, HXQ4/A, LJG1, LSX, LSX/A, LX, LX/A, LXF, LXQ4, LXQ4/A, LXZ, LX2, LX2/A, PX, PX/A, QE, QE/A, QX, QX/A, QXB, QXB7, QXB7/A, QXC, QXC/A, QXC9, QXC9/A, QXE, QXE/A, QXE4, QXE4/A, QXQ4, QXQ4/A, QXU, QXU/A, RTB2, RTB2/A, RX, RX/A, RXQ4, RXQ4/A, SE, SE/A, SNC1, SNE1, SX, SX/A, SXB, SXE, SXEB, SXE4, SXE4/A, SXQ4, SXQ4/A, SXU, SXU/A, VMX, VNG, VWC2, VWC2/A, VX, VX/A, VXB, VXB7, VXB7/A, VXE, VXE/A, VXEB, VXEB/A, VXQ4, VXQ4/A, VXQ7, VXQ7/A, VXU, VXU/A, VXU1, VXU1/A
			-	(3)	3		
16	17233-896-701	COLLAR, AIR CLEANER CASE	(2)	-	(2)		HXQ4, HXQ4/A, LXQ4, LXQ4/A, QE/A, QXB7, QXB7/A, QXE4, QXE4/A, QXQ4, QXQ4/A, RXQ4, RXQ4/A, SE/A, SNC1, SNE1, SXE4, SXE4/A, SXQ4, SXQ4/A, VXB7, VXB7/A, VXQP, VXQ4, VXQ4/A, VXQ7, VXQ7/A
			(2)	-	-	3302522	QE, QXB, SE, SXB
17	18430-ZF6-W50	DEFLECTOR COMP., MUFFLER	(1)	-	-		QE, QE/A, SE, SE/A

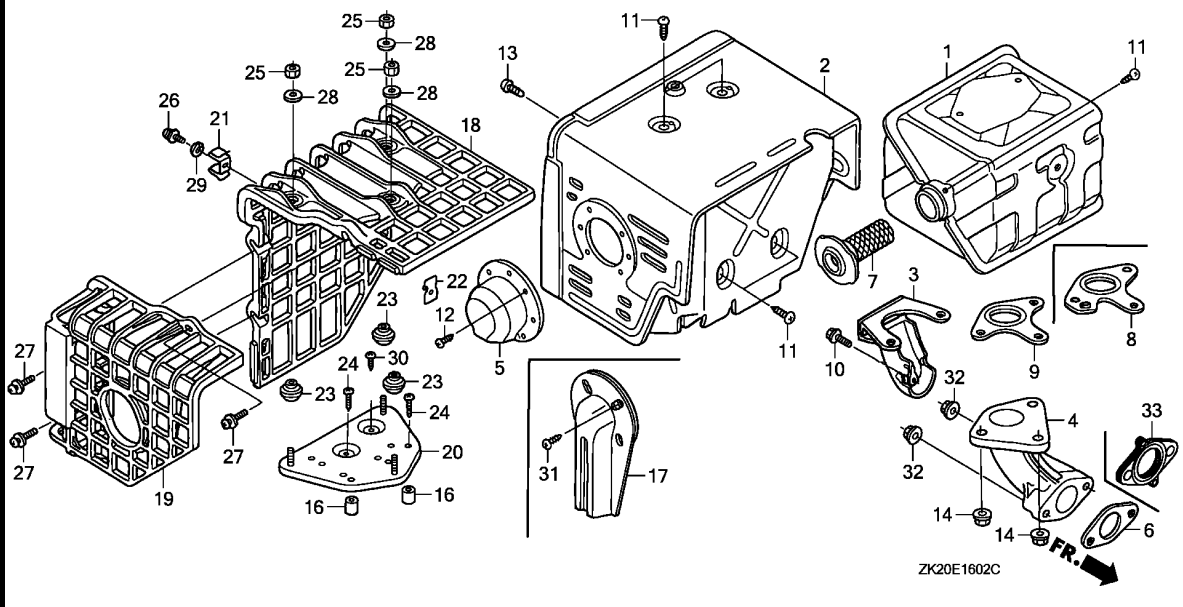

Ref. No.	Part No.	Description	Reqd. QTY			Serial No.	Parts catalogue code	
			(1)	(2)	(3)			
17)	18430-ZK9-W50	DEFLECTOR COMP., MUFFLER	(1)	-	-	-----	HXQ4, HXQ4/A, LXQ4, LXQ4/A, QXB7, QXB7/A, QXQ4, QXQ4/A, RXQ4, RXQ4/A, SXQ4, SXQ4/A	
18	18433-ZF6-W40	COVER COMP., MUFFLER	(1)	-	(1)	-----	HXQ4, HXQ4/A, LXQ4, LXQ4/A, QE/A, QXB7, QXB7/A, QXE4, QXE4/A, QXQ4, QXQ4/A, RXQ4, RXQ4/A, SE/A, SNC1, SNE1, SXE4, SXE4/A, SXQ4, SXQ4/A, VXB7, VXB7/A, VXQP, VXQ4, VXQ4/A, VXQ7, VXQ7/A	
19	18434-ZF6-W40	COVER COMP., MUFFLER RR.	(1)	-	-	3302522	-----	QE, QXB, SE, SXB
20	18436-ZH8-W40	BASE COMP., MUFFLER COVER	(1)	-	(1)	3302522	-----	HXQ4, HXQ4/A, LXQ4, LXQ4/A, QE/A, QXB7, QXB7/A, QXE4, QXE4/A, QXQ4, QXQ4/A, RXQ4, RXQ4/A, SE/A, SNC1, SNE1, SXE4, SXE4/A, SXQ4, SXQ4/A, VXB7, VXB7/A, VXQP, VXQ4, VXQ4/A, VXQ7, VXQ7/A
			(1)	-	-	3302522	-----	QE, QXB, SE, SXB
21	18437-ZF6-W40	STAY, MUFFLER COVER	(1)	-	(1)	-----	HXQ4, HXQ4/A, LXQ4, LXQ4/A, QE/A, QXB7, QXB7/A, QXE4, QXE4/A, QXQ4, QXQ4/A, RXQ4, RXQ4/A, SE/A, SNC1, SNE1, SXE4, SXE4/A, SXQ4, SXQ4/A, VXB7, VXB7/A, VXQP, VXQ4, VXQ4/A, VXQ7, VXQ7/A	
			(1)	-	-	3302522	-----	QE, QXB, SE, SXB
22	18438-ZF6-W40	PLATE, SET	(1)	-	(1)	-----	HXQ4, HXQ4/A, LXQ4, LXQ4/A, QE/A, QXB7, QXB7/A, QXE4, QXE4/A, QXQ4, QXQ4/A, RXQ4, RXQ4/A, SE/A, SNC1, SNE1, SXE4, SXE4/A, SXQ4, SXQ4/A, VXB7, VXB7/A, VXQP, VXQ4, VXQ4/A, VXQ7, VXQ7/A	
			(1)	-	-	3302522	-----	QE, QXB, SE, SXB
23	18466-ZH8-W40	SPACER, MUFFLER COVER	(3)	-	(3)	-----	HXQ4, HXQ4/A, LXQ4, LXQ4/A, QE/A, QXB7, QXB7/A, QXE4, QXE4/A, QXQ4, QXQ4/A, RXQ4, RXQ4/A, SE/A, SNC1, SNE1, SXE4, SXE4/A, SXQ4, SXQ4/A, VXB7, VXB7/A, VXQP, VXQ4, VXQ4/A, VXQ7, VXQ7/A	
			(3)	-	-	3302522	-----	QE, QXB, SE, SXB

Ref. No.	Part No.	Description	Reqd. QTY			Serial No.	Parts catalogue code
			(1)	(2)	(3)		
24	90050-ZH8-W40	SCREW, TAPPING, 5X25	(2)	-	(2)		HXQ4, HXQ4/A, LXQ4, LXQ4/A, QE/A, QXB7, QXB7/A, QXE4, QXE4/A, QXQ4, QXQ4/A, RXQ4, RXQ4/A, SE/A, SNC1, SNE1, SXE4, SXE4/A, SXQ4, SXQ4/A, VXQ4, VXQ4/A, VXQ7, VXQ7/A
25	90302-KF9-900	NUT, HEX., 5MM	(2)	-	-	3302522	QE, QXB, SE, SXB
			(3)	-	(3)		HXQ4, HXQ4/A, LXQ4, LXQ4/A, QE/A, QXB7, QXB7/A, QXE4, QXE4/A, QXQ4, QXQ4/A, RXQ4, RXQ4/A, SE/A, SNC1, SNE1, SXE4, SXE4/A, SXQ4, SXQ4/A, VXQ4, VXQ4/A, VXQ7, VXQ7/A
			(3)	-	-	3302522	QE, QXB, SE, SXB
26	93891-05012-00	SCREW-WASHER, 5X12	(1)	-	(1)		HXQ4, HXQ4/A, LXQ4, LXQ4/A, QE/A, QXB7, QXB7/A, QXE4, QXE4/A, QXQ4, QXQ4/A, RXQ4, RXQ4/A, SE/A, SNC1, SNE1, SXE4, SXE4/A, SXQ4, SXQ4/A, VXQ4, VXQ4/A, VXQ7, VXQ7/A
			(1)	-	-	3302522	QE, QXB, SE, SXB
27	93891-06020-07	SCREW-WASHER, 6X20	(3)	-	(3)		HXQ4, HXQ4/A, LXQ4, LXQ4/A, QE/A, QXB7, QXB7/A, QXE4, QXE4/A, QXQ4, QXQ4/A, RXQ4, RXQ4/A, SE/A, SNC1, SNE1, SXE4, SXE4/A, SXQ4, SXQ4/A, VXQ4, VXQ4/A, VXQ7, VXQ7/A
			(3)	-	-	3302522	QE, QXB, SE, SXB
28	94103-05700	WASHER, PLAIN, 5MM	(3)	-	(3)		HXQ4, HXQ4/A, LXQ4, LXQ4/A, QE/A, QXB7, QXB7/A, QXE4, QXE4/A, QXQ4, QXQ4/A, RXQ4, RXQ4/A, SE/A, SNC1, SNE1, SXE4, SXE4/A, SXQ4, SXQ4/A, VXQ4, VXQ4/A, VXQ7, VXQ7/A
			(3)	-	-	3302522	QE, QXB, SE, SXB
29	94111-05000	WASHER, SPRING, 5MM	(1)	-	(1)		HXQ4, HXQ4/A, LXQ4, LXQ4/A, QE/A, QXB7, QXB7/A, QXE4, QXE4/A, QXQ4, QXQ4/A, RXQ4, RXQ4/A, SE/A, SNC1, SNE1, SXE4, SXE4/A, SXQ4, SXQ4/A, VXQ4, VXQ4/A, VXQ7, VXQ7/A
			(1)	-	-	3302522	QE, QXB, SE, SXB
30	90050-ZE1-000	SCREW, TAPPING, 5X8	(1)	-	(1)		HXQ4, HXQ4/A, LXQ4, LXQ4/A, QE/A, QXB7, QXB7/A, QXE4, QXE4/A, QXQ4, QXQ4/A, RXQ4, RXQ4/A, SE/A, SNC1, SNE1, SXE4, SXE4/A, SXQ4, SXQ4/A, VXQ4, VXQ4/A, VXQ7, VXQ7/A
			(1)	-	-	3302522	QE, QXB, SE, SXB
31	90050-ZE1-000	SCREW, TAPPING, 5X8	(2)	-	-		QE, QE/A, SE, SE/A
	90055-ZE1-000	SCREW, TAPPING, 4X6	(2)	-	-		HXQ4, HXQ4/A, LXQ4, LXQ4/A, QXB7, QXB7/A, QXQ4, QXQ4/A, RXQ4, RXQ4/A, SXQ4, SXQ4/A
32	94050-08000	NUT, FLANGE, 8MM	2	-	-		ES, ES1, ES1/A, ES2, HX, HX/A, HXQ4, HXQ4/A, LJG1, LSX, LSX/A, LX, LX/A, LXF, LXQ4, LXQ4/A, LXZ, LX2, LX2/A, PX, PX/A, QE, QE/A, QX, QX/A, QXB, QXB7, QXB7/A, QXC, QXC/A, QXC9, QXC9/A, QXE, QXE/A, QXEB, QXE4, QXE4/A, QXQ4, QXQ4/A, QXU, QXU/A, RTB2, RTB2/A, RX, RX/A, RXQ4, RXQ4/A, SE, SE/A, SNC1, SNE1, SX, SX/A, SXB, SXE, SXEB, SXE4, SXE4/A, SXQ4, SXQ4/A, SXU, SXU/A, VMX, VNG, VWC2, VWC2/A, VX, VX/A, VXB, VXB/A, VXB7, VXB7/A, VXE, VXE/A, VXEB, VXEB/A, VXQ4, VXQ4/A, VXQ7, VXQ7/A, VXU, VXU/A, VXU1, VXU1/A
33	18333-ZF6-W01	GASKET, EX. PIPE	-	(2)	2		ES1/A, ES2, HX/A, HXQ4/A, LSX/A, LX/A, LXF, LXQ4/A, LX2/A, PX/A, QE/A, QX/A, QXB7, QXB7/A, QXC/A, QXC9/A, QXE/A, QXE4/A, QXQ4/A, QXU/A, RTB2/A, RX/A, RXQ4/A, SE/A, SX/A, SXE4/A, SXQ4/A, SXU/A, VWC2/A, VX/A, VXB/A, VXB7, VXB7/A, VXE/A, VXEB/A, VXQ4/A, VXQ7, VXQ7/A, VXU/A, VXU1/A
			1	-	-	3844353	ES, ES1, HX, HXQ4, LJG1, LSX, LX, LXQ4, LX2, PX, QE, QX, QXC, QXC9, QXE, QXE4, QXQ4, QXU, RTB2, RX, RXQ4, SE, SX, SXE4, SXQ4, SXU, VMX, VWC2, VX, VXB, VXE, VXEB, VXQ4, VXU, VXU1
			-	-	1		



E-16-3

MUFFLER(4)

M15

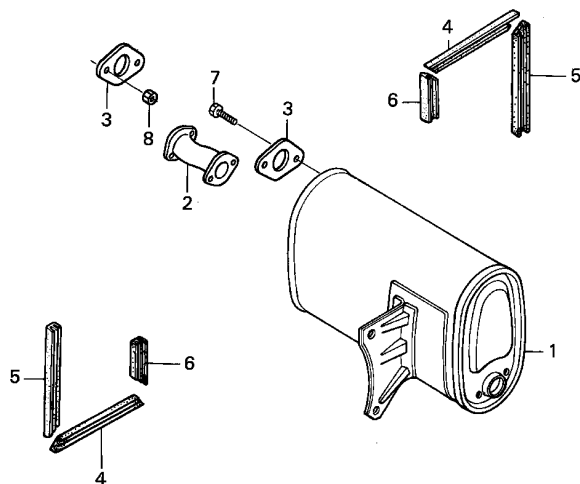

ZK20-E1603A

Ref. No.	L.O.N.	(Relative ref. Number) Description	F.R.T.
1	3131C5	MUFFLER, EXHAUST	0.2
2	3131C9	PIPE, EXHAUST	0.2
3	3131B5	GASKET, EXHAUST PIPE	0.2

Ref. No.	Part No.	Description	Reqd. QTY			Serial No.	Parts catalogue code
			GX240K1				
			(1)	(2)	(3)		
1	18310-ZB7-003	MUFFLER COMP.	1	-	-	-----	EDS5,SJP,SMS,SMS/A
2	18330-ZB7-003	PIPE COMP., EX.	1	-	-	-----	SJP,SMS,SMS/A
3	18333-ZB7-800	GASKET, EX. PIPE	2	-	-	-----	EDS5,SJP,SMS,SMS/A
4	18412-ZB7-000	SEAL, MUFFLER DUCT (A)	2	-	-	-----	EDS5
5	18413-ZB7-000	SEAL, MUFFLER DUCT (B)	2	-	-	-----	EDS5
6	18414-ZB7-000	SEAL, MUFFLER DUCT (C)	2	-	-	-----	EDS5
7	92101-08028-0A	BOLT, HEX., 8X28	2	-	-	-----	EDS5
8	94001-08000-0S	NUT, HEX., 8MM	2	-	-	-----	EDS5

2

E-16-4

MUFFLER(5)

M16

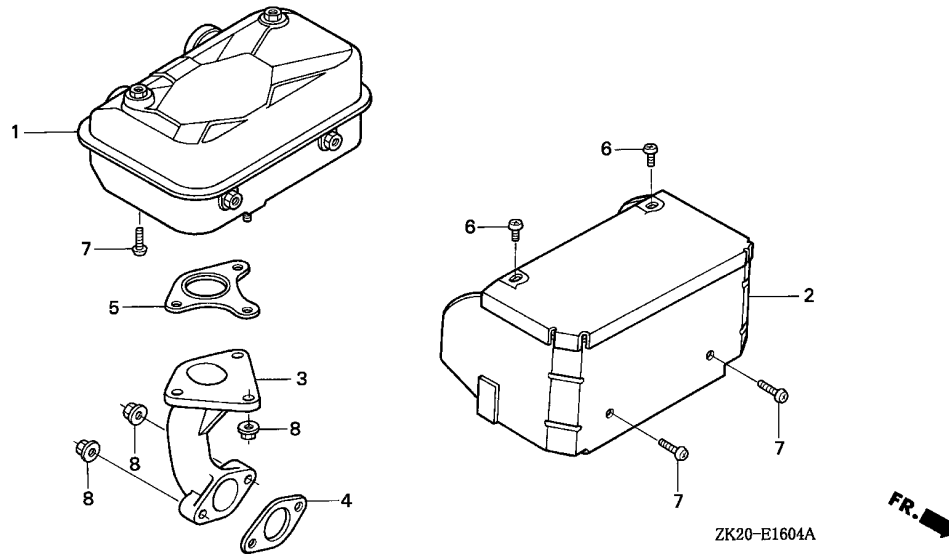

Ref. No.	L.O.N.	(Relative ref. Number) Description	F.R.T.
1	3131C5	MUFFLER, EXHAUST	0.2
2	3131D8	PROTECTOR, EXHAUST MUFFLER :INNER	0.2
3	3131C9	PIPE, EXHAUST	0.2
4	3131B5	GASKET, EXHAUST PIPE	0.2
5	3131B4	GASKET, EXHAUST MUFFLER	0.2

Ref. No.	Part No.	Description	Reqd. QTY			Serial No.	Parts catalogue code
			GX240K1				
			(1)	(2)	(3)		
1	18310-ZE2-A01	MUFFLER COMP.	1	-	-	3081408	LNJ
	18310-ZE2-A11	1	-	-	-----	LNZ
2	18325-ZE2-A00	PROTECTOR, MUFFLER INNER	1	-	-	3081409	LNJ
	18325-ZE2-A10	1	-	-	-----	LNZ
3	18330-ZE2-000	PIPE, EX.	1	-	-	-----	LNJ, LNZ
4	18333-ZE3-800	GASKET, EX. PIPE	1	-	-	-----	LNJ, LNZ
5	18381-ZE2-800	GASKET, MUFFLER	1	-	-	-----	LNZ
			1	-	-	3104110	LNJ
6	93500-06006-0B	SCREW, PAN, 6X6	2	-	-	-----	LNJ, LNZ
7	93500-06012-0B	SCREW, PAN, 6X12	4	-	-	-----	LNJ, LNZ
8	94050-08000	NUT, FLANGE, 8MM	5	-	-	-----	LNJ, LNZ

2

E-16-5

MUFFLER(6)

N 1

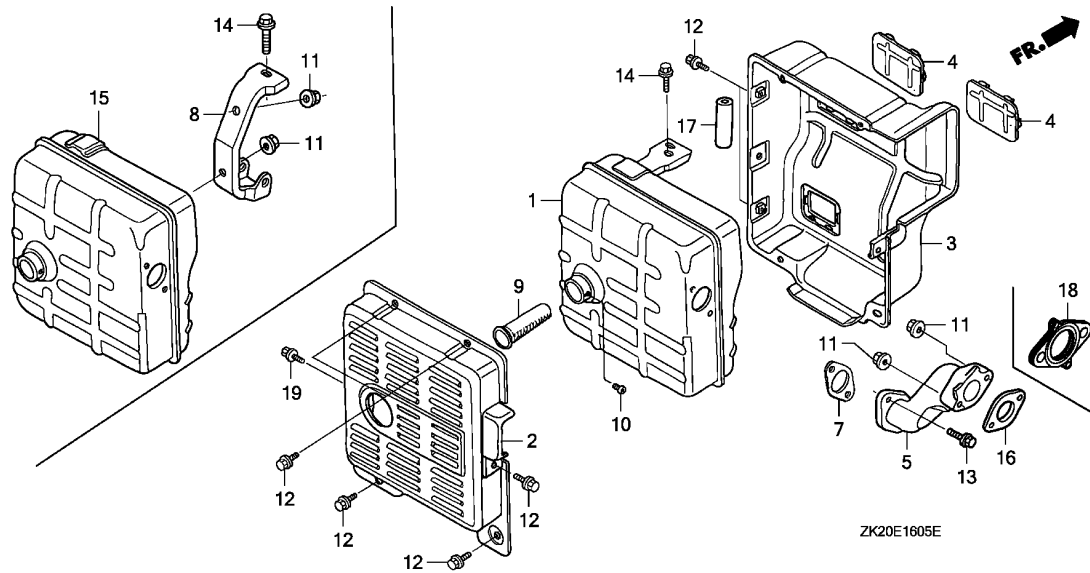

Ref. No.	L.O.N.	(Relative ref. Number) Description	F.R.T.
1		(15)	
1	3131C5	MUFFLER, EXHAUST	0.2
2	3131D9	PROTECTOR, EXHAUST MUFFLER : OUTER	0.1
3	3131D8	PROTECTOR, EXHAUST MUFFLER : INNER	0.2
4	3131G6	SEAL, MUFFLER PROTECTOR	0.2
5	3131C9	PIPE, EXHAUST	0.2
7	3131B5	GASKET, EXHAUST PIPE	0.2
9	3131A1	ARRESTER, SPARK	0.2

ZK20E1605E

Ref. No.	Part No.	Description	Reqd. QTY			Serial No.	Parts catalogue code
			(1)	(2)	(3)		
1	18310-ZD1-E31	MUFFLER COMP.	1	-	-	-----	EDS,EDS1,EDS1/A,EDS2,EDS2/A,EDS3,EDS6,EDS6/A,EDT1,EDT1/A,EDT2,EDT3,EDT6,EDT6/A,ES3,ES3/A,VS1,VS1/A
	18310-ZE2-U90	MUFFLER COMP. (DENYO)	1	-	-	3337056	ED2
2	18320-ZB4-000	PROTECTOR, MUFFLER OUTER	1	-	-	-----	EDN,EDN2,EDN2/A,EDS,EDS1,EDS1/A,EDS2,EDS2/A,EDS3,EDS6,EDS6/A,EDT1,EDT1/A,EDT2,EDT3,EDT6,EDT6/A,ED2,ED2/A,ES3,ES3/A,VS1,VS1/A,VS3,VS4,VTE2
3	18325-ZB4-000	PROTECTOR, MUFFLER INNER	1	-	-	-----	EDN,EDN2,EDN2/A,EDS,EDS1,EDS1/A,EDS2,EDS2/A,EDS3,EDS6,EDS6/A,EDT1,EDT1/A,EDT2,EDT3,EDT6,EDT6/A,ED2,ED2/A,EN2,EN2/A,ES3,ES3/A,VS1,VS1/A,VS3,VS4,VTE2
4	18329-ZB4-000	SEAL, MUFFLER PROTECTOR	2	-	-	-----	EDN,EDN2,EDN2/A,EDS,EDS1,EDS1/A,EDS2,EDS2/A,EDS3,EDS6,EDS6/A,EDT1,EDT1/A,EDT2,EDT3,EDT6,EDT6/A,ED2,ED2/A,EN2,EN2/A,ES3,ES3/A,VS1,VS1/A,VS3,VS4,VTE2
5	18330-ZE2-710	PIPE, EX.	1	-	-	-----	EDS,EDS1,EDS1/A,EDS2,EDS2/A,EDS3,EDS6,EDS6/A,EDT1,EDT1/A,EDT2,EDT3,EDT6,EDT6/A
	18330-ZE2-700	1	-	-	3351281	ED2
			1	-	-	3351282	EDN,EDN2,EDN2/A,ED2/A,EN2,EN2/A,ES3,ES3/A,VS1,VS1/A,VS3,VS4,VTE2
7	18333-ZB4-800	GASKET, EX. PIPE	1	-	-	-----	EDN,EDN2,EDN2/A,EDS,EDS1,EDS1/A,EDS2,EDS2/A,EDS3,EDS6,EDS6/A,EDT1,EDT1/A,EDT2,EDT3,EDT6,EDT6/A,ED2,ED2/A,EN2,EN2/A,ES3,ES3/A,VS1,VS1/A,VS3,VS4,VTE2
8	18338-ZE2-V60	STAY A, MUFFLER (TSURUMI) ...	1	-	-	-----	ED2/A,VTE2
			1	-	-	3337057	ED2
9	18355-ZB4-630	ARRESTER, SPARK	1	-	-	-----	EDN,EDN2,EDN2/A,EDS,EDS1,EDS1/A,EDS2,EDS2/A,EDS3,EDS6,EDS6/A,EDT1,EDT1/A,EDT2,EDT3,EDT6,EDT6/A,ED2,ED2/A,EN2,EN2/A,VTE2
10	90002-ZE2-U91	SCREW, TAPPING, 4X8	1	-	-	-----	EDN,EDN2,EDN2/A,EDS,EDS1,EDS1/A,EDS2,EDS2/A,EDS3,EDS6,EDS6/A,EDT1,EDT1/A,EDT2,EDT3,EDT6,EDT6/A,ED2,ED2/A,EN2,EN2/A,VTE2

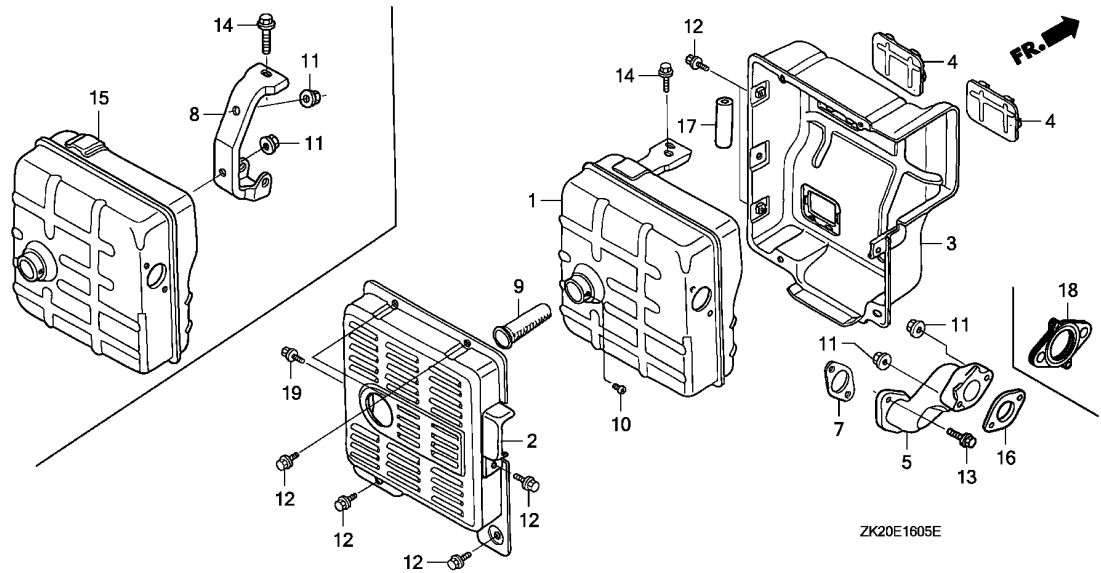

ZK20E1605E



Ref. No.	Part No.	Description	Reqd. QTY			Serial No.	Parts catalogue code
			(1)	(2)	(3)		
11	94050-08000	NUT, FLANGE, 8MM	2	-	-	EDN,EDN2,EDN2/A,EDS,EDS1,EDS1/A,EDS2,EDS2/A,EDS3,EDS6,EDS6/A,EDT1,EDT1/A,EDT2,EDT3,EDT6,EDT6/A,ES3,ES3/A,VS1,VS1/A,VS3,VS4	
			2	-	-	3337056 ED2	
			2	-	-	EDT3,VS4	
			4	-	-	ED2/A,EN2,EN2/A,VTE2	
			4	-	-	3337057 ED2	
12	95701-06010-00	BOLT, FLANGE, 6X10	7	-	-	EDT1,EDT2,EDT6,EDT6/A,ED2,ED2/A,EN2,EN2/A,VTE2	
	95701-06012-00	BOLT, FLANGE, 6X12	7	-	-	4861096 EDT1/A	
			7	-	-	4861097 EDS,EDS1,EDS1/A,EDS2,EDS2/A,EDS3,EDS6,EDS6/A,EDT3	
			7	-	-	EDT1/A	
13	95701-08020-00	BOLT, FLANGE, 8X20	2	-	-	EDN,EDN2,EDN2/A,EDS,EDS1,EDS1/A,EDS2,EDS2/A,EDS3,EDS6,EDS6/A,EDT1,EDT1/A,EDT2,EDT3,EDT6,EDT6/A,ED2,ED2/A,EN2,EN2/A,VTE2	
14	95701-08070-00	BOLT, FLANGE, 8X70	1	-	-	ED2,ED2/A,VTE2	
15	18310-ZE2-V60	MUFFLER COMP. (TSURUMI)	1	-	-	ED2/A,EN2,EN2/A,VS3,VS4,VTE2	
			1	-	-	3337057 ED2	
16	18333-ZE3-800	GASKET, EX. PIPE	1	-	-	EDN,EDN2,EDN2/A,EDS,EDS1,EDS2,EDS2/A,EDS3,EDS6,EDS6/A,EDT1,EDT2,EDT6,EDT6/A,ED2,ED2/A,EN2,EN2/A,ES3,VS1,VTE2	
			1	-	-	4825591 EDS1/A,EDT1/A,ES3/A,VS1/A,VS3	
17	18301-ZE2-V60	COLLAR, 10X16X53	1	-	-	ED2,ED2/A,EN2	
18	18333-ZF6-W01	GASKET, EX. PIPE	1	-	-	EDT3,VS4	
			1	-	-	4825592 EDS1/A,EDT1/A,ES3/A,VS1/A,VS3	
19	95701-06010-00	BOLT, FLANGE, 6X10	1	-	-	EDT1,EDT1/A,EDT2,EDT3,EDT6,EDT6/A,ED2,ED2/A,EN2,EN2/A,VTE2	
	95701-06012-00	BOLT, FLANGE, 6X12	1	-	-	EDS,EDS1,EDS2,EDS2/A,EDS3,EDS6,EDS6/A	
			1	-	-	4861096 EDS1/A	
	95701-06010-00	BOLT, FLANGE, 6X10	1	-	-	4861097 EDS1/A	

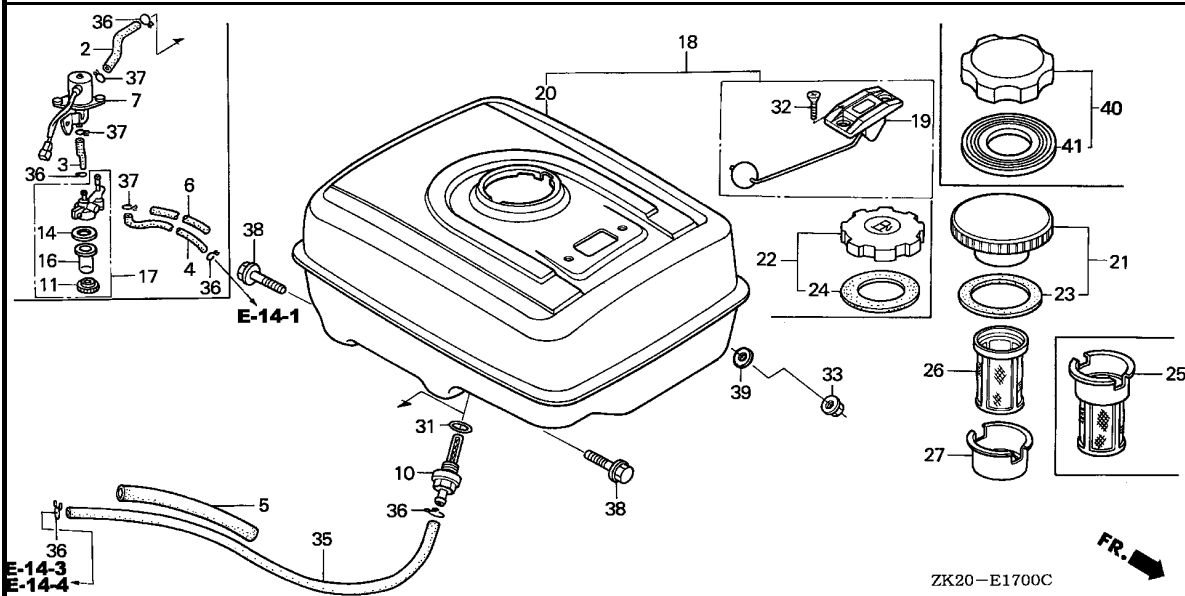

Ref. No.	L.O.N.	(Relative ref. Number) Description	F.R.T.
2	3101F2	TUBE, FUEL COCK	0.2
7	3101H0	VALVE, ELECTRIC FUEL	0.2
10		(31)	
	3101H6	JOINT, FUEL STRAINER	0.2
17	3101F4	CUP, FUEL STRAINER	0.2
18	3101E1	TANK ASSEMBLY, FUEL	0.3
19	6171A1	METER/GAUGE UNIT, FUEL	0.1
20	3101H7	TANK, FUEL	0.3
26		(25)	
	3101A6	FILTER, FUEL	0.1
35	3101F6	TUBE, FUEL	0.2

ZK20-E1700C



Ref. No.	Part No.	Description	Reqd. QTY			Serial No.	Parts catalogue code
			(1)	(2)	(3)		
			GX240K1				
2	16851-ZE2-V40	TUBE, FUEL TANK AUTO FUEL COCK	1	-	-	-----	WKA
3	16852-ZB7-000	TUBE, FUEL (COCK-STRAINER) ..	1	-	-	-----	WKA
4	16853-ZE2-V40	TUBE, STRAINER CARBURETOR ...	1	-	-	-----	WKA
5	16854-ZE1-000	RUBBER, SUPPORTER (107MM) ...	1	-	-	3033265	LJ,LK,RJ,SJ,SK,STP,STQ,WJ
	16854-ZH8-000	1	(1)	-	3140234	L1,P1,Q1,R1,S1,V1,W1
							HTX,LJ/A,LJG,LJG/A,LJG1,LJS,LJS/A,LM9,LNJ,LNZ,LSS5,LSS5/A,LSX LSX/A,LXF,L1/A,QHB2,Q1/A,RJ/A,RSS1,RSS1/A,R1/A,SJ/A,SJC,SJC1 SJC1/A,SJC5,SJC5/A,SJG,SJG/A,SMS,SMS/A,SNR,SNR/A,STP/A,STQ/A,S1/A WJ/A,W1/A
			1	-	-	3033266	LJ,LK,RJ,SJ,SK,STP,STQ,WJ
			-	(1)	-	3140235	L1,P1,Q1,R1,S1,V1,W1
6	16857-ZE2-V40	SUPPORTER, FUEL TUBE	2	-	-	-----	WKA
7	16930-ZB7-013	COCK ASSY., ELECTRIC FUEL ...	1	-	-	-----	WKA
10	16955-ZE1-000	JOINT, FUEL TANK	1	-	-	-----	HTX,LJ,LJ/A,LJG,LJG/A,LJG1,LJS,LJS/A,LK,LM9,LNJ,LNZ,LSS5,LSS5/A LSX,LSX/A,LXF,QHB2,RJ,RJ/A,RSS1,RSS1/A,SJ,SJ/A,SJC,SJC1,SJC1/A SJC5,SJC5/A,SJG,SJG/A,SK,SMS,SMS/A,SNR,SNR/A,STP,STP/A,STQ,STQ/A WJ,WJ/A,WKA
			-	(1)	-		
11	16957-707-005	NUT, RING	1	-	-	-----	WKA
14	16963-443-901	GASKET	1	-	-	-----	WKA
16	16967-196-005	CUP, FUEL STRAINER	1	-	-	-----	WKA
17	16990-ZB7-005	CUP ASSY., FUEL STRAINER	1	-	-	-----	WKA
18	17500-ZE2-8112A	TANK ASSY., FUEL (GAUGE) *NH31*.....MCKINLEY WHITE	1	(1)	-	-----	HTX,LJG,LJG1,LJS,LM9,LNJ,LNZ,LSS5,L1,P1,Q1,RSS1,R1,SJG,SMS,SNR,S1 V1,W1
			1	(1)	-	4583903	LJG/A,LJS/A,LSS5/A,L1/A,Q1/A,RSS1/A,R1/A,SJG/A,SMS/A,SNR/A,S1/A W1/A

Ref. No.	Part No.	Description	Reqd. QTY			Serial No.	Parts catalogue code
			(1)	(2)	(3)		
18)	17500-ZE2-812ZA	TANK ASSY., FUEL (GAUGE) *NH31*.....MCKINLEY WHITE	1	(1)	-	4583904 4775184	LJG/A,LJS/A,LSS5/A,L1/A,Q1/A,RSS1/A,R1/A,SJG/A,SMS/A,SNR/A,S1/A W1/A
			1	-	-	----- 4775184	LXF
	17500-ZE2-813ZA	*NH31*.....MCKINLEY WHITE	1	(1)	-	4775185	LJG/A,LJS/A,LSS5/A,LXF,L1/A,Q1/A,RSS1/A,R1/A,SJG/A,SMS/A,SNR/A S1/A,W1/A
19	17505-ZE2-013	GAUGE ASSY., FUEL	1	-	-	-----	HTX,LJG,LJG/A,LJG1,LJS,LJS/A,LM9,LNJ,LNZ,LSS5,LSS5/A,LXF,RSS1 RSS1/A,SJG,SJG/A,SMS,SMS/A,SNR,SNR/A
			-	(1)	-		
20	17510-ZE2-010ZA	TANK COMP., FUEL *NH31*.....MCKINLEY WHITE	1	(1)	-	-----	LJ,LK,LSX,L1,P1,Q1,RJ,R1,SJ,SJC,SJC1,SJC5,SK,STP,STQ,S1,V1,WJ,WKA W1
			1	(1)	-	----- 4568628	LJ/A,LSX/A,L1/A,Q1/A,RJ/A,R1/A,SJ/A,SJC1/A,SJC5/A,STP/A,STQ/A S1/A,WJ/A,W1/A
	17510-ZE2-020ZA	*NH31*.....MCKINLEY WHITE	1	(1)	-	4568629 4776725	LJ/A,LSX/A,L1/A,Q1/A,RJ/A,R1/A,SJ/A,SJC1/A,SJC5/A,STP/A,STQ/A S1/A,WJ/A,W1/A
			1	-	-	----- 4776725	QHB2
	17510-ZE2-800ZC	*NH31*.....MCKINLEY WHITE	1	(1)	-	4776726 4845181	LJ/A,LSX/A,L1/A,Q1/A,RJ/A,R1/A,SJ/A,SJC1/A,SJC5/A,STP/A,S1/A,WJ/A W1/A
			1	-	-	----- 4776726	QHB2,STQ/A
	17510-ZE2-801ZC	*NH31*.....MCKINLEY WHITE	1	(1)	-	4845182	LJ/A,LSX/A,L1/A,Q1/A,RJ/A,R1/A,SJ/A,SJC1/A,SJC5/A,STP/A,S1/A,WJ/A W1/A
21	17620-ZE2-W00	CAP COMP., FUEL FILLER (CHROME PLATED)	1	(1)	-	----- 3254423	HTX,LJ,LK,LM9,LNJ,LNZ,L1,P1,Q1,RJ,R1,SJ,SK,SNR,STP,STQ,S1,V1,WJ WKA,W1
22	17620-ZH7-023	CAP COMP., FUEL FILLER (BLACK)	1	(1)	-	3254424	HTX,LJ,LK,LM9,LNJ,LNZ,L1,P1,Q1,RJ,R1,SJ,SK,SNR,STP,STQ,S1,V1,WJ WKA,W1
			1	(1)	-	----- 4495553	LJ/A,LJG/A,LJS/A,LSS5/A,LSX/A,L1/A,Q1/A,RJ/A,RSS1/A,R1/A,SJ/A SJC1/A,SJC5/A,SJG/A,SMS/A,SNR/A,STP/A,STQ/A,S1/A,WJ/A,W1/A
			1	-	-	-----	LJG,LJG1,LJS,LSS5,LSX,RSS1,SJC,SJC1,SJC5,SJG,SMS
23	17631-329-003	PACKING, FUEL FILLER CAP (39X58X3)	1	(1)	-	----- 3254423	HTX,LJ,LK,LM9,LNJ,LNZ,L1,P1,Q1,RJ,R1,SJ,SK,SNR,STP,STQ,S1,V1,WJ WKA,W1
24	17631-ZH7-003	PACKING, FUEL FILLER CAP (39X58X3)	1	(1)	-	3254424	HTX,LJ,LK,LM9,LNJ,LNZ,L1,P1,Q1,RJ,R1,SJ,SK,SNR,STP,STQ,S1,V1,WJ WKA,W1
			1	(1)	-	----- 4495553	LJ/A,LJG/A,LJS/A,LSS5/A,LSX/A,L1/A,Q1/A,RJ/A,RSS1/A,R1/A,SJ/A SJC1/A,SJC5/A,SJG/A,SMS/A,SNR/A,STP/A,STQ/A,S1/A,WJ/A,W1/A
			1	-	-	-----	LJG,LJG1,LJS,LSS5,LSX,RSS1,SJC,SJC1,SJC5,SJG,SMS
25	17672-ZE2-W01	FILTER, FUEL	1	(1)	-	-----	LJ/A,LJG,LJG/A,LJG1,LJS,LJS/A,LNZ,LSS5,LSS5/A,LSX,LSX/A,LXF,L1/A Q1/A,RJ/A,RSS1,RSS1/A,R1/A,SJ/A,SJC,SJG,SJG/A,SMS,SMS/A,SNR/A STP/A,STQ/A,S1/A,WJ/A,W1/A
			1	(1)	-	3640465	LJ,LK,LM9,LNJ,L1,P1,Q1,RJ,R1,SJ,SK,SNR,STP,STQ,S1,V1,WJ,WKA,W1
			1	-	-	----- 3640464	SJC1,SJC5
26	17672-880-000	FILTER, FUEL	1	(1)	-	3118370 3190916	LJ,LK,LM9,LNJ,L1,P1,Q1,RJ,R1,SJ,SK,SNR,STP,STQ,S1,V1,WJ,WKA,W1
			1	-	-	-----	SJC1/A,SJC5/A
			1	-	-	3640465	SJC1,SJC5
27	17673-893-000	HOLDER, FUEL FILTER	1	(1)	-	3118370 3190916	LJ,LK,LM9,LNJ,L1,P1,Q1,RJ,R1,SJ,SK,SNR,STP,STQ,S1,V1,WJ,WKA,W1
			1	-	-	-----	SJC1/A,SJC5/A
			1	-	-	3640465	SJC1,SJC5
31	91353-671-004	O-RING, 14MM(NOK)	1	-	-	-----	HTX,LJ,LJ/A,LJG,LJG/A,LJG1,LJS,LJS/A,LK,LM9,LNJ,LNZ,LSS5,LSS5/A LSX,LSX/A,LXF,QHB2,RJ,RJ/A,RSS1,RSS1/A,SJ,SJ/A,SJC,SJC1,SJC1/A SJC5,SJC5/A,SJG,SJG/A,SK,SMS,SMS/A,SNR,SNR/A,STP,STP/A,STQ,STQ/A WJ,WJ/A,WKA
			-	(1)	-		

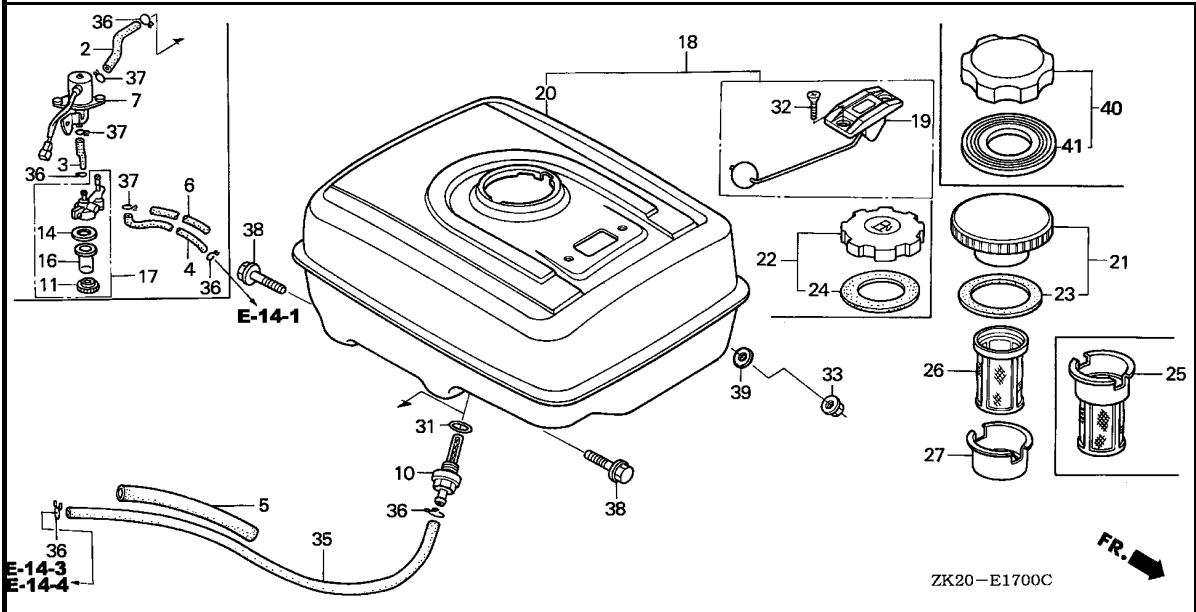

ZK20-E1700C

Ref. No.	Part No.	Description	Reqd. QTY			Serial No.	Parts catalogue code
			(1)	(2)	(3)		
32	93600-05010-0A	SCREW, FLAT, 5X10	2	-	-	HTX,LJG,LJG/A,LJG1,LJS,LJS/A,LM9,LNJ,LNZ,LSS5,LSS5/A,LXF,RSS1 RSS1/A,SJG,SJG/A,SMS,SMS/A,SNR,SNR/A	
33	94050-08000	NUT, FLANGE, 8MM	2	(2)	-	HTX,LJ,LJ/A,LJG,LJG/A,LJG1,LJS,LJS/A,LK,LM9,LNJ,LNZ,LSS5,LSS5/A LSX,LSX/A,LXF,QHB2,RJ,RJ/A,RSS1,RSS1/A,SJ,SJ/A,SJC,SJC1,SJC1/A SJC5,SJC5/A,SJG,SJG/A,SK,SMS,SMS/A,SNR,SNR/A,STP,STP/A,STQ,STQ/A WJ,WJ/A,WKA	
35	95001-45222-40 (95001-45001-60M)	TUBE, FUEL, 4.5X222	1	(2)	-	HTX,LJ,LJ/A,LJG,LJG/A,LJG1,LJS,LJS/A,LK,LM9,LNJ,LNZ,LSS5,LSS5/A LSX,LSX/A,LXF,QHB2,RJ,RJ/A,RSS1,RSS1/A,SJ,SJ/A,SJC,SJC1,SJC1/A SJC5,SJC5/A,SJG,SJG/A,SK,SMS,SMS/A,SNR,SNR/A,STP,STP/A,STQ,STQ/A WJ,WJ/A	
36	95002-02080	CLIP, TUBE (B8)	2	(1)	-	HTX,LJ,LJ/A,LJG,LJG/A,LJG1,LJS,LJS/A,LK,LM9,LNJ,LNZ,LSS5,LSS5/A LSX,LSX/A,LXF,QHB2,RJ,RJ/A,RSS1,RSS1/A,SJ,SJ/A,SJC,SJC1,SJC1/A SJC5,SJC5/A,SJG,SJG/A,SK,SMS,SMS/A,SNR,SNR/A,STP,STP/A,STQ,STQ/A WJ,WJ/A	
			3	-	-	WKA	
37	95002-02100	CLIP, TUBE (B10)	3	(2)	-	WKA	
38	95701-08025-00	BOLT, FLANGE, 8X25	2	-	-	HTX,LJ,LJ/A,LJG,LJG/A,LJG1,LJS,LJS/A,LK,LM9,LNJ,LNZ,LSS5,LSS5/A LSX,LSX/A,LXF,QHB2,RJ,RJ/A,RSS1,RSS1/A,SJ,SJ/A,SJC,SJC1,SJC1/A SJC5,SJC5/A,SJG,SJG/A,SK,SMS,SMS/A,SNR,SNR/A,STP,STP/A,STQ,STQ/A WJ,WJ/A,WKA	
39	94101-08000	WASHER, PLAIN, 8MM	2	(2)	-	SJC5,SJC5/A,SMS,SMS/A,SNR,SNR/A	

E-17

FUEL TANK(1)

N 6

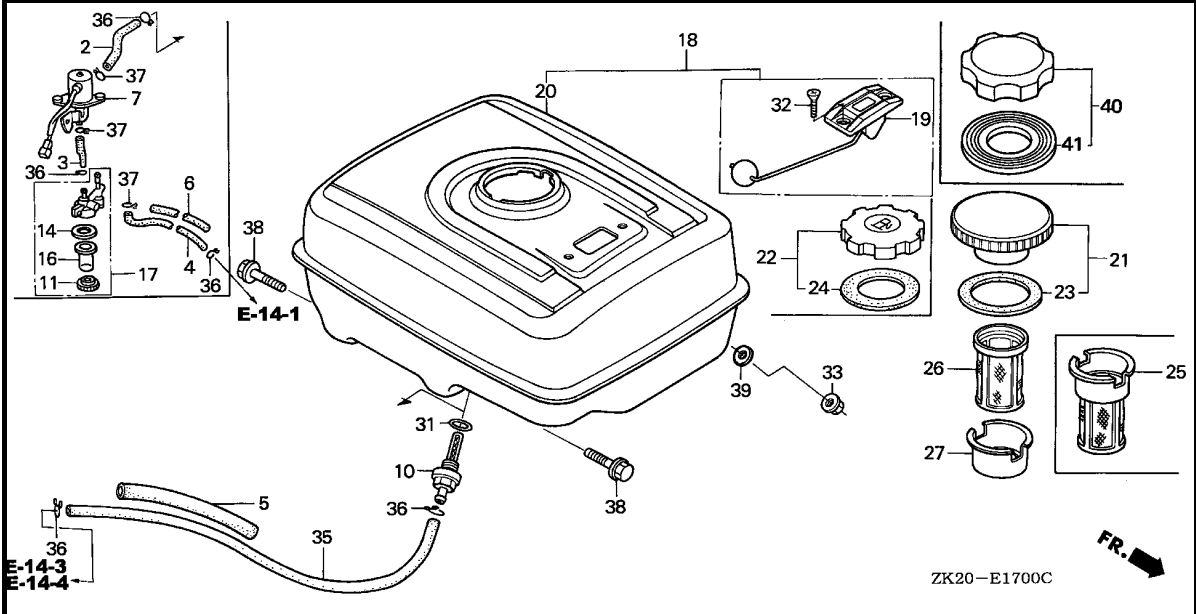

Ref. No.	Part No.	Description	Reqd. QTY			Serial No.	Parts catalogue code
			GX240K1				
			(1)	(2)	(3)		
40	17620-Z0T-305	CAP COMP., FUEL FILLER (CHROME PLATED)	1	(1)	-	4495554 -----	LJ/A,LJG/A,LJS/A,LSS5/A,LSX/A,L1/A,Q1/A,RJ/A,RSS1/A,R1/A,SJ/A SJC1/A,SJC5/A,SJG/A,SMS/A,SNR/A,STP/A,STQ/A,S1/A,WJ/A,W1/A LXF,QHB2
41	17631-Z0T-812	PACKING, FUEL FILLER CAP (39X62X3)	1	(1)	-	4495554 -----	LJ/A,LJG/A,LJS/A,LSS5/A,LSX/A,L1/A,Q1/A,RJ/A,RSS1/A,R1/A,SJ/A SJC1/A,SJC5/A,SJG/A,SMS/A,SNR/A,STP/A,STQ/A,S1/A,WJ/A,W1/A LXF,QHB2

2

E-17-1

FUEL TANK(2)

N 7

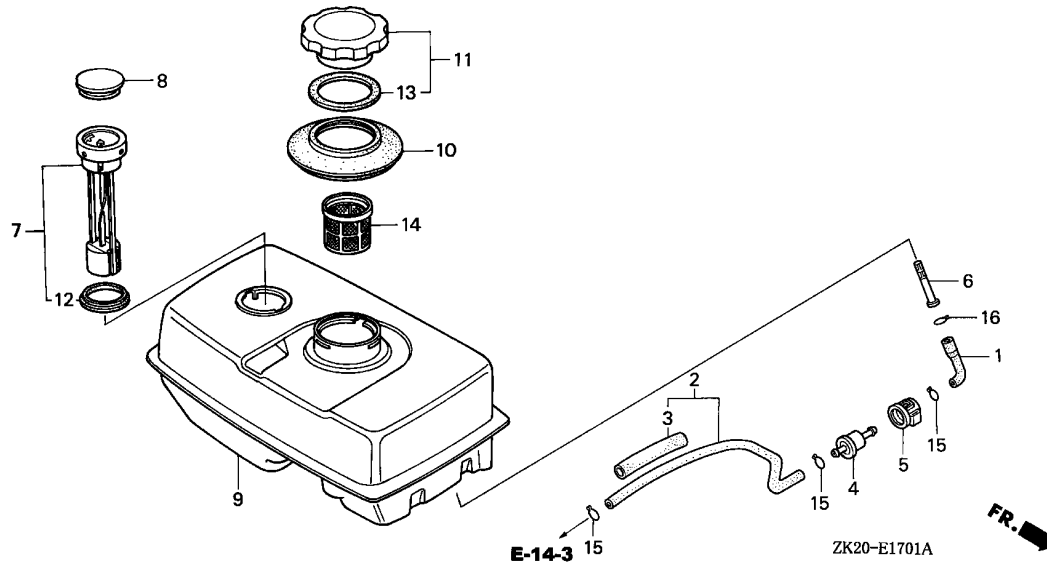

Ref. No.	L.O.N.	(Relative ref. Number) Description	F.R.T.
1	3101F1	TUBE, FUEL TANK	0.1
2	3101G0	TUBE, FUEL STRAINER	0.2
4	3101H8	STRAINER, FUEL	0.1
6	3101H6	JOINT, FUEL STRAINER	0.2
7	6171A1	METER/GAUGE UNIT, FUEL	0.1
9	3101D0	TANK, FUEL(A)	0.2
14	3101A6	FILTER, FUEL	0.1

Ref. No.	Part No.	Description	Reqd. QTY			Serial No.	Parts catalogue code
			GX240K1				
			(1)	(2)	(3)		
1	16852-ZB6-000	TUBE, FUEL TANK	1	-	-	-----	SJP
2	16854-ZB6-000	TUBE ASSY., COCK-CARBURETOR ..	1	-	-	-----	SJP
3	16857-ZB6-000	RUBBER, SUPPORTER	1	-	-	-----	SJP
4	16910-GB2-005	STRAINER COMP., FUEL	1	-	-	-----	SJP
5	16915-GB2-000	SUSPENSION, STRAINER	1	-	-	-----	SJP
6	16952-ZB6-000	BUSH, FUEL PURGE	1	-	-	-----	SJP
7	17505-898-023	METER COMP., FUEL	1	-	-	-----	SJP
8	17507-ZA0-800	CAP, FUEL METER	1	-	-	-----	SJP
9	17510-ZB6-010	TANK COMP., FUEL	1	-	-	-----	SJP
10	17520-ZA0-800	SEAL, FUEL FILLER NECK	1	-	-	-----	SJP
11	17620-899-013	CAP COMP., FUEL FILLER	1	-	-	-----	SJP
12	17624-187-020	PACKING C, FUEL METER	1	-	-	-----	SJP
13	17631-899-000	PACKING, FUEL FILLER CAP	1	-	-	-----	SJP
14	17670-ZB6-000	FILTER COMP., FUEL	1	-	-	-----	SJP
15	95002-02080	CLIP, TUBE (B8)	3	-	-	-----	SJP
16	95002-02100	CLIP, TUBE (B10)	1	-	-	-----	SJP

E-17-2

FUEL TANK(3)

N 8

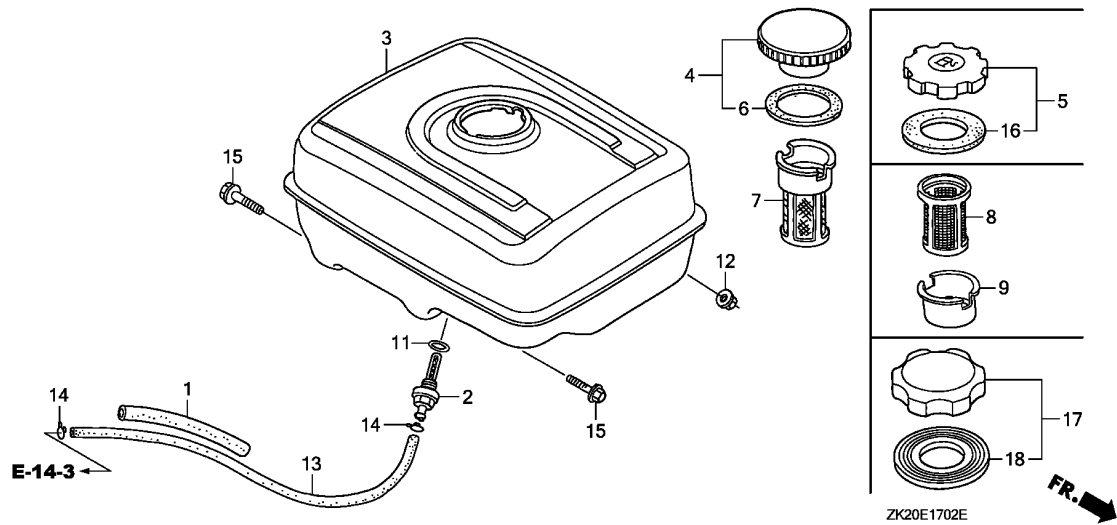

Ref. No.	L.O.N.	(Relative ref. Number) Description	F.R.T.
2	3101H6	(11) JOINT, FUEL STRAINER	0.2
3	3101D0	TANK, FUEL(A)	0.2
7	3101A6	(8) FILTER, FUEL	0.1
13	3101F6	TUBE, FUEL	0.2

Ref. No.	Part No.	Description	Reqd. QTY			Serial No.	Parts catalogue code
			(1)	(2)	(3)		
1	16854-ZE1-000	RUBBER, SUPPORTER (107MM) ...	1	-	-	3033265	HA, PA, QA, QAE, QXC, RA, VA
	16854-ZH8-000	1	-	-		HAQ, HA2, HA2/A, LX2, LX2/A, PAE, PA2, PA2/A, PMT2, PMT2/A, QAE2, QAE2/A, QAG QAG/A, QAG2, QAG2/A, QAQ, QA2, QA2/A, QW24, QXC/A, QXC9, QXC9/A, RA2, RA2/A SMX2, SMX2/A, VA2, VA2/A, VTA, WKT2, WKT2/A
2	16955-ZE1-000	JOINT, FUEL TANK	1	-	-	3033266	HA, PA, QA, QAE, QXC, RA, VA
			1	-	-		HA, HAQ, HA2, HA2/A, LX2, LX2/A, PA, PAE, PA2, PA2/A, PMT2, PMT2/A, QA, QAE QAE2, QAE2/A, QAG, QAG/A, QAG2, QAG2/A, QAQ, QA2, QA2/A, QW24, QXC, QXC/A QXC9, QXC9/A, RA, RA2, RA2/A, SMX2, SMX2/A, VA, VA2, VA2/A, WKT2, WKT2/A
3	17510-ZE2-010ZA	TANK COMP., FUEL *NH31*.....MCKINLEY WHITE	1	-	-		HA, HAQ, HA2, LX2, PA, PAE, PA2, QA, QAE, QAE2, QAG, QAG2, QAQ, QA2, QXC, QXC9 RA, RA2, SMX2, VA, VA2, WKT2
			1	-	-	4568628	HA2/A, LX2/A, PA2/A, QAE2/A, QAG/A, QAG2/A, QA2/A, QXC/A, QXC9/A, RA2/A SMX2/A, VA2/A, WKT2/A
	17510-ZE2-010ZD	*NH1*.....BLACK	1	-	-		HA2, LX2, PA2, PMT2, QAE2, QAG, QA2, QXC9, RA2, SMX2, VA2
			1	-	-	3139635	HA, QA
			1	-	-	3187181	HAQ, QAQ
			1	-	-	4568628	HA2/A, LX2/A, PA2/A, PMT2/A, QAE2/A, QAG/A, QA2/A, QXC9/A, RA2/A, SMX2/A VA2/A
	17510-ZE2-020ZA	*NH31*.....MCKINLEY WHITE	1	-	-	4776725	HA2/A, LX2/A, PA2/A, QAE2/A, QAG/A, QAG2/A, QA2/A, QXC/A, QXC9/A, RA2/A SMX2/A, VA2/A, WKT2/A
	17510-ZE2-020ZD	*NH1*.....BLACK	1	-	-	4776725	QW24
			1	-	-	4568629	HA2/A, LX2/A, PA2/A, PMT2/A, QAE2/A, QAG/A, QA2/A, QXC9/A, RA2/A, SMX2/A VA2/A
	17510-ZE2-800ZA	*NH1*.....BLACK	1	-	-	4776726	HA2/A, LX2/A, PA2/A, PMT2/A, QAE2/A, QAG/A, QA2/A, QW24, QXC9/A, RA2/A SMX2/A, VA2/A
	17510-ZE2-800ZC	*NH31*.....MCKINLEY WHITE	1	-	-	4776726	HA2/A, LX2/A, PA2/A, PMT2/A, QAE2/A, QAG/A, QAG2/A, QA2/A, QXC9/A, RA2/A SMX2/A, VA2/A, WKT2/A
			1	-	-	4776726	4845181 QXC/A
	17510-ZE2-801ZC	*NH31*.....MCKINLEY WHITE	1	-	-	4845182	4845182 QXC/A

2

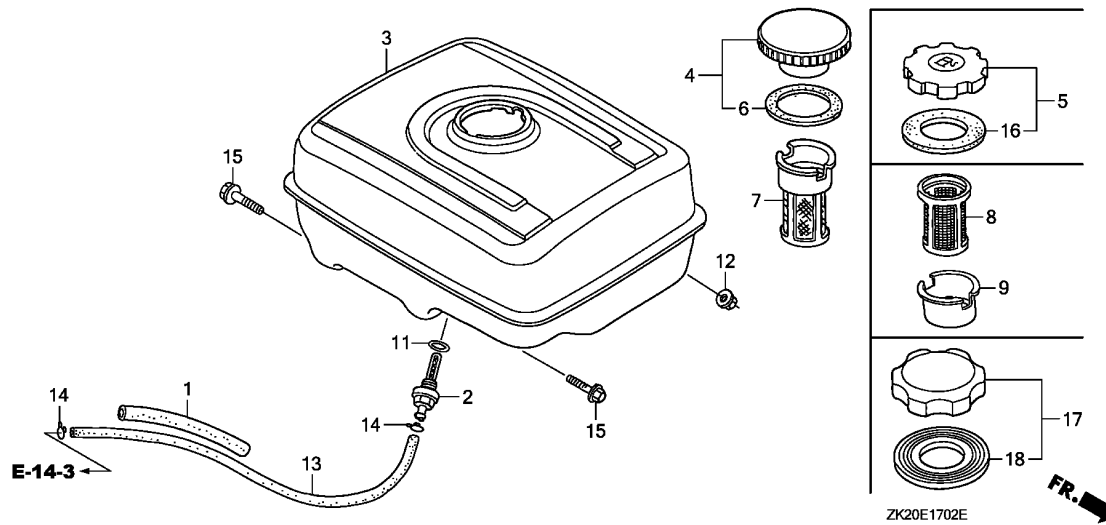

Ref. No.	Part No.	Description	Reqd. QTY			Serial No.	Parts catalogue code
			(1)	(2)	(3)		
4	17620-ZE2-W00	CAP COMP., FUEL FILLER (CHROME PLATED)	1	-	-	3254423	HA, HAQ, HA2, LX2, PA, PAE, PA2, QA, QAE, QAE2, QAQ, QA2, QXC, RA, RA2, VA, VA2
5	17620-ZH7-023	CAP COMP., FUEL FILLER (BLACK)	1	-	-	-----	PMT2, QAG, QAG2, QXC9, SMX2, WKT2
			1	-	-	3254424	HA, HAQ, HA2, LX2, PA, PAE, PA2, QA, QAE, QAE2, QAQ, QA2, QXC, RA, RA2, VA, VA2
			1	-	-	4495553	HA2/A, LX2/A, PA2/A, PMT2/A, QAE2/A, QAG/A, QAG2/A, QA2/A, QXC/A, QXC9/A, RA2/A, SMX2/A, VA2/A, WKT2/A
6	17631-329-003	PACKING, FUEL FILLER CAP (39X58X3)	1	-	-	3254423	HA, HAQ, HA2, LX2, PA, PAE, PA2, QA, QAE, QAE2, QAQ, QA2, QXC, RA, RA2, VA, VA2
7	17672-ZE2-W01	FILTER, FUEL	1	-	-	-----	HA2/A, PAE, PA2/A, QAE2/A, QAG, QAG/A, QAG2, QAG2/A, QA2/A, QW24, RA2/A, SMX2, SMX2/A, VA2/A, WKT2, WKT2/A
			1	-	-	3190917	HA, HAQ, HA2, PA, PA2, QA, QAE, QAE2, QAQ, QA2, RA, RA2, VA, VA2
8	17672-880-000	FILTER, FUEL	1	-	-	3190916	HAQ, HA2, PA2, QAE2, QAQ, QA2, RA2, VA2
			1	-	-	3118370	HA, PA, QA, QAE, RA, VA
9	17673-893-000	HOLDER, FUEL FILTER	1	-	-	3190916	HAQ, HA2, PA2, QAE2, QAQ, QA2, RA2, VA2
			1	-	-	3118370	HA, PA, QA, QAE, RA, VA
11	91353-671-004	O-RING, 14MM(NOK)	1	-	-	-----	HA, HAQ, HA2, HA2/A, LX2, LX2/A, PA, PAE, PA2, PA2/A, PMT2, PMT2/A, QA, QAE, QAE2, QAE2/A, QAG, QAG/A, QAG2, QAG2/A, QAQ, QA2, QA2/A, QW24, QXC, QXC/A, QXC9, QXC9/A, RA, RA2, RA2/A, SMX2, SMX2/A, VA, VA2, VA2/A, WKT2, WKT2/A
12	94050-08000	NUT, FLANGE, 8MM	2	-	-	-----	HA, HAQ, HA2, HA2/A, LX2, LX2/A, PA, PAE, PA2, PA2/A, PMT2, PMT2/A, QA, QAE, QAE2, QAE2/A, QAG, QAG/A, QAG2, QAG2/A, QAQ, QA2, QA2/A, QW24, QXC, QXC/A, QXC9, QXC9/A, RA, RA2, RA2/A, SMX2, SMX2/A, VA, VA2, VA2/A, WKT2, WKT2/A
13	95001-45222-40	TUBE, FUEL, 4.5X222 (95001-45001-60M)	1	-	-	-----	HA, HAQ, HA2, HA2/A, LX2, LX2/A, PA, PAE, PA2, PA2/A, PMT2, PMT2/A, QA, QAE, QAE2, QAE2/A, QAG, QAG/A, QAG2, QAG2/A, QAQ, QA2, QA2/A, QW24, QXC, QXC/A, QXC9, QXC9/A, RA, RA2, RA2/A, SMX2, SMX2/A, VA, VA2, VA2/A, VTA, VTA2, VTA2/A, WKT2, WKT2/A

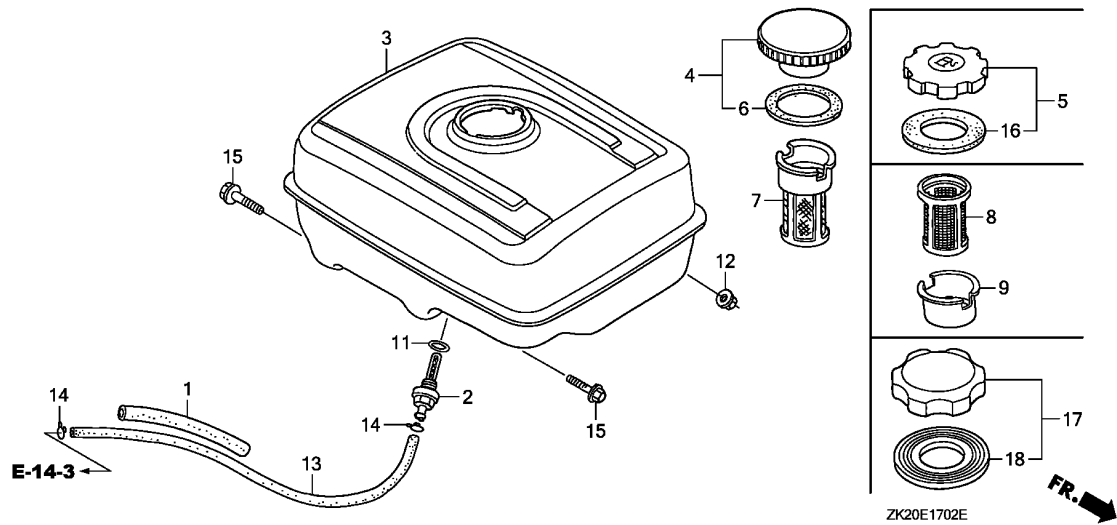

Ref. No.	Part No.	Description	Reqd. QTY			Serial No.	Parts catalogue code
			GX240K1				
			(1)	(2)	(3)		
14	95002-02080	CLIP, TUBE (B8)	2	-	-	-----	HA,HAQ,HA2,HA2/A,LX2,LX2/A,PA,PAE,PA2,PA2/A,PMT2,PMT2/A,QA,QAE,QAE2,QAE2/A,QAG,QAG/A,QAG2,QAG2/A,QAQ,QA2,QA2/A,QW24,QXC,QXC/A,QXC9,QXC9/A,RA,RA2,RA2/A,SMX2,SMX2/A,VA,VA2,VA2/A,VTA,VTA2,VTA2/A,WKT2,WKT2/A
15	95701-08025-00	BOLT, FLANGE, 8X25	2	-	-	-----	HA,HAQ,HA2,HA2/A,LX2,LX2/A,PA,PAE,PA2,PA2/A,PMT2,PMT2/A,QA,QAE,QAE2,QAE2/A,QAG,QAG/A,QAG2,QAG2/A,QAQ,QA2,QA2/A,QW24,QXC,QXC/A,QXC9,QXC9/A,RA,RA2,RA2/A,SMX2,SMX2/A,VA,VA2,VA2/A,WKT2,WKT2/A
16	17631-ZH7-003	PACKING, FUEL FILLER CAP (39X58X3)	1	-	-	-----	PMT2,QAG,QAG2,QXC9,SMX2,WKT2
			1	-	-	3254424	HA,HAQ,HA2,LX2,PA,PAE,PA2,QA,QAE,QAE2,QAQ,QA2,QXC,RA,RA2,VA,VA2
			1	-	-	4495553	HA2/A,LX2/A,PA2/A,PMT2/A,QAE2/A,QAG/A,QAG2/A,QA2/A,QXC/A,QXC9/A,RA2/A,SMX2/A,VA2/A,WKT2/A
17	17620-Z0T-305	CAP COMP., FUEL FILLER (CHROME PLATED)	1	-	-	-----	QW24
			1	-	-	4495554	HA2/A,LX2/A,PA2/A,PMT2/A,QAE2/A,QAG/A,QAG2/A,QA2/A,QXC/A,QXC9/A,RA2/A,SMX2/A,VA2/A,WKT2/A
18	17631-Z0T-812	PACKING, FUEL FILLER CAP (39X62X3)	1	-	-	-----	QW24
			1	-	-	4495554	HA2/A,LX2/A,PA2/A,PMT2/A,QAE2/A,QAG/A,QAG2/A,QA2/A,QXC/A,QXC9/A,RA2/A,SMX2/A,VA2/A,WKT2/A



E-17-3

FUEL TANK(4)

N11

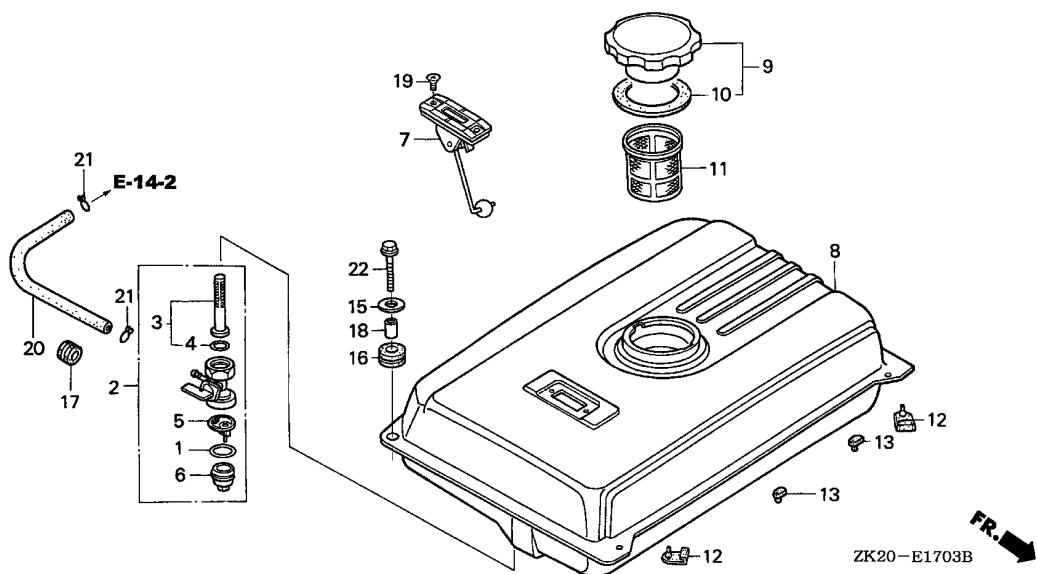

Ref. No.	L.O.N.	(Relative ref. Number) Description	F.R.T.
2	3101A3	COCK, FUEL (4)	0.2
3	3101D5	SCREEN, FUEL STRAINER (1,6)	0.2
5	3101A7	FILTER, FUEL TANK CUP	0.2
7	6171A1	METER/GAUGE UNIT, FUEL	0.1
8	3101D0	TANK, FUEL(A)	0.2
11	3101A6	FILTER, FUEL	0.1
20	3101F6	TUBE, FUEL	0.2

Ref. No.	Part No.	Description	Reqd. QTY			Serial No.	Parts catalogue code
			(1)	(2)	(3)		
			GX240K1				
1	16173-001-004	PACKING, FUEL STRAINER CUP ..	1	-	-	-----	EDN,EDN2,EDN2/A,EDS,EDS1,EDS1/A,EDS2,EDS2/A,EDS3,EDS6,EDS6/A,EDT1 EDT1/A,EDT2,EDT3,EDT6,EDT6/A,ED2,ED2/A,ES3,ES3/A,VS1,VS1/A,VS3 VS4,VTE2
2	16950-ZB4-015	COCK ASSY., FUEL	1	-	-	-----	EDN,EDN2,EDN2/A,EDS,EDS1,EDS1/A,EDS2,EDS2/A,EDS3,EDS6,EDS6/A,EDT1 EDT1/A,EDT2,EDT3,EDT6,EDT6/A,ED2,ED2/A,ES3,ES3/A,VS1,VS1/A,VS3 VS4,VTE2
3	16952-ZB4-005	SCREEN, FUEL STRAINER	1	-	-	-----	EDN,EDN2,EDN2/A,EDS,EDS1,EDS1/A,EDS2,EDS2/A,EDS3,EDS6,EDS6/A,EDT1 EDT1/A,EDT2,EDT3,EDT6,EDT6/A,ED2,ED2/A,ES3,ES3/A,VS1,VS1/A,VS3 VS4,VTE2
4	16958-397-771	O-RING	1	-	-	-----	EDN,EDN2,EDN2/A,EDS,EDS1,EDS1/A,EDS2,EDS2/A,EDS3,EDS6,EDS6/A,EDT1 EDT1/A,EDT2,EDT3,EDT6,EDT6/A,ED2,ED2/A,ES3,ES3/A,VS1,VS1/A,VS3 VS4,VTE2
5	16959-471-831	FILTER, CUP	1	-	-	-----	EDN,EDN2,EDN2/A,EDS,EDS1,EDS1/A,EDS2,EDS2/A,EDS3,EDS6,EDS6/A,EDT1 EDT1/A,EDT2,EDT3,EDT6,EDT6/A,ED2,ED2/A,ES3,ES3/A,VS1,VS1/A,VS3 VS4,VTE2
6	16967-GA6-671	CUP, FUEL STRAINER	1	-	-	-----	EDN,EDN2,EDN2/A,EDS,EDS1,EDS1/A,EDS2,EDS2/A,EDS3,EDS6,EDS6/A,EDT1 EDT1/A,EDT2,EDT3,EDT6,EDT6/A,ED2,ED2/A,ES3,ES3/A,VS1,VS1/A,VS3 VS4,VTE2
7	17505-ZB2-003	METER ASSY., FUEL	1	-	-	-----	EDS,ED2,ED2/A,ES3,ES3/A,VS1,VS1/A,VS3,VS4,VTE2
8	17510-ZB4-000ZA	TANK COMP., FUEL	1	-	-	-----	ED2,ED2/A
	17510-ZB4-000ZB	*NH31*.....MCKINLEY WHITE	1	-	-	-----	EDS,ED2
		R8.....BRIGHT RED	1	-	-	4466632	ED2/A
	17510-ZB4-000ZC	*NH1*.....BLACK	1	-	-	-----	ED2,ED2/A
	17510-ZB4-000ZE	*T68*.....TSURUMI BLUE	1	-	-	-----	ED2,ED2/A
	17510-ZB4-000ZF	*Y131*.....LIGHTNING YELLOW	1	-	-	-----	ED2,ED2/A
	17510-ZB4-000ZH	*R280*.....POWER RED	1	-	-	4466633	ED2/A
9	17620-899-013	CAP COMP., FUEL FILLER	1	-	-	-----	EDS,ED2,ED2/A,ES3,ES3/A,VS1,VS1/A,VS3,VS4,VTE2

Ref. No.	Part No.	Description	Reqd. QTY			Serial No.	Parts catalogue code
			(1)	(2)	(3)		
10	17631-899-000	PACKING, FUEL FILLER CAP	1	-	-	-----	EDS,ED2,ED2/A,ES3,ES3/A,VSB1,VSB1/A,VS3,VS4,VTE2
11	17670-899-000	FILTER COMP., FUEL	1	-	-	-----	EDS,ED2,ED2/A,ES3,ES3/A,VSB1,VSB1/A,VS3,VS4,VTE2
12	50319-ZB2-000	RUBBER, TANK MOUNTING	2	-	-	-----	EDS,EDS1,EDS1/A,EDS2,EDS2/A,EDS3,EDS6,EDS6/A,EDT1,EDT1/A,EDT2 EDT3,EDT6,EDT6/A,ED2,ED2/A,ES3,VTE2
13	76122-952-000	STOPPER, DISCHARGE GUARD	2	-	-	-----	EDS
			2	-	-	3416473	ED2
			4	-	-	-----	VS3,VS4
15	90503-898-000	WASHER, TANK CUSHION	2	-	-	-----	EDS,ED2,ED2/A,VTE2
			2	-	-	3140184	ES3
			4	-	-	-----	VS3,VS4
16	90851-898-000	RUBBER, TANK CUSHION	2	-	-	-----	EDS,ED2,ED2/A,VTE2
			2	-	-	3140184	ES3
			4	-	-	-----	VS3,VS4
17	90854-ZB2-000	RUBBER, FUEL (9X15X10)	1	-	-	-----	EDN,EDN2,EDN2/A,EDS,EDS1,EDS1/A,EDS2,EDS2/A,EDS3,EDS6,EDS6/A,EDT1 EDT1/A,EDT2,EDT3,EDT6,EDT6/A,ED2/A,EN2,EN2/A,ES3,ES3/A,VSB1 VSB1/A,VS3,VS4,VTE2
18	91551-898-000	COLLAR, TANK CUSHION	1	-	-	3502863	ED2
			2	-	-	-----	EDS,ED2,ED2/A,VTE2
			2	-	-	3140184	ES3
			4	-	-	-----	VS3,VS4
19	93600-05010-0A	SCREW, FLAT, 5X10	2	-	-	-----	EDS,ED2,ED2/A,ES3,ES3/A,VSB1,VSB1/A,VTE2
20	95001-45190-40	TUBE, FUEL, 4.5X190 (95001-45001-60M)	1	-	-	-----	EDN,EDN2,EDN2/A
	95001-45260-40	TUBE, FUEL, 4.5X260 (95001-45001-60M)	1	-	-	3502862	ED2
	95001-45180-40	TUBE, FUEL, 4.5X180 (95001-45001-60M)	1	-	-	-----	ED2/A,VTE2
			1	-	-	3502863	ED2
	95001-45150-40	TUBE, FUEL, 4.5X150 (95001-45001-60M)	1	-	-	-----	EDS,EDS1,EDS2,EDS2/A,EDS3,EDS6,EDS6/A,EDT1,EDT2,EDT6,EDT6/A,EN2 ES3,ES3/A,VSB1,VSB1/A,VS3,VS4
			1	-	-	4780489	EN2/A
			1	-	-	4861096	EDS1/A,EDT1/A
	95001-45165-40	TUBE, FUEL, 4.5X165 (95001-45001-60M)	1	-	-	4780490	EN2/A
	95001-45180-40	TUBE, FUEL, 4.5X180 (95001-45001-60M)	1	-	-	-----	EDT3
			1	-	-	4861097	EDS1/A,EDT1/A
21	95002-02080	CLIP, TUBE (B8)	2	-	-	-----	EDN,EDN2,EDN2/A,EDS,EDS1,EDS1/A,EDS2,EDS2/A,EDS3,EDS6,EDS6/A,EDT1 EDT1/A,EDT2,EDT3,EDT6,EDT6/A,ED2,ED2/A,EN2,EN2/A,ES3,ES3/A,VSB1 VSB1/A,VS3,VS4,VTE2
22	95701-06022-00	BOLT, FLANGE, 6X22	2	-	-	-----	EDS,ED2,ED2/A,VTE2
	95701-08025-00	BOLT, FLANGE, 8X25	2	-	-	-----	EDS1,EDS1/A,EDT1,EDT1/A



E-17-4

FUEL TANK(5)

N13

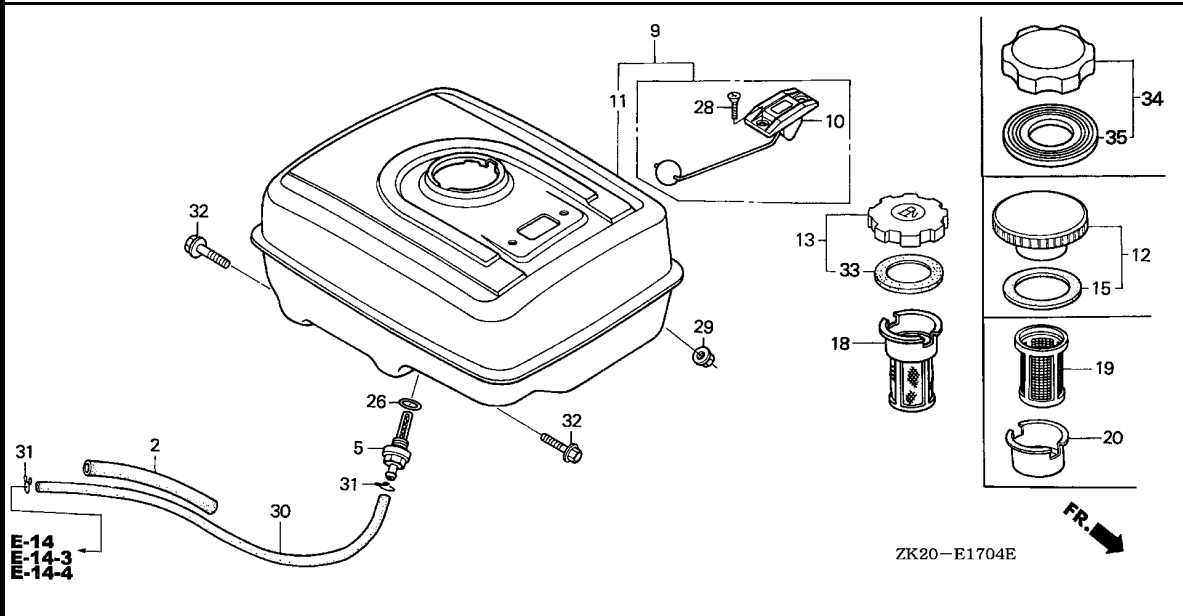

Ref. No.	L.O.N.	(Relative ref. Number) Description	F.R.T.
5	(26)		
5	3101H6	JOINT, FUEL STRAINER	0.2
9	3101S5	TANK ASSEMBLY, FUEL(A)	0.2
10	6171A1	METER/GAUGE UNIT, FUEL	0.1
11	3101D0	TANK, FUEL(A)	0.2
18	(19)		
18	3101A6	FILTER, FUEL	0.1
30	3101F6	TUBE, FUEL	0.2

ZK20-E1704E



Ref. No.	Part No.	Description	Reqd. QTY			Serial No.	Parts catalogue code
			(1)	(2)	(3)		
2	16854-ZE1-000	RUBBER, SUPPORTER (107MM) ...	1	-	-	3033265	HH,HX,LD,LH,LHE,LW,LX,LXZ,PX,QD,QDA,QE,QH,QHC,QHE,QT,QX,QXB,QXE,QXEB,RD,RH,RHE,RX,SD,SE,SH,SHE,SHEZ,SW,SWE,SX,SXB,SXE,SXEB,VH,VXVXB,VXE,VXEB,WH
	16854-ZH8-000	-	(1)	-	3140234	L1,P1,Q1,R1,V1,W1
			1	(1)	-	3140235	ED3,ED4,ED4/A,ED5,ED5/A,ES,ES1,ES1/A,ES2,HHQ4,HHQ4/A,HX/A,HXQ4,HXQ4/A,LDB1,LH/A,LHE4,LHE4/A,LHZ,LKS,LKS/A,LP,LP/A,LSS4,LT,LT/A,LX/A,LXQ4,LXQ4/A,L1/A,PX/A,QAB2,QAB2/A,QAQ4,QAR2,QAR2/A,QC12,QC12/A,QD/A,QE/A,QH/A,QHP1,QHP1/A,QHQ4,QHQ4/A,QHZ,QKA2,QMH,QMH/A,QMX2,QP,QP/A,QT/A,QTC2,QTC2/A,QX/A,QXB7,QXB7/A,QXE/A,QXE4,QXE4/A,QXQ4,QXQ4/A,QXU,QXU/A,Q1/A,RD/A,RHE4,RHQ4,RHQ4/A,RTB2,RTB2/A,RX/A,RXQ4,RXQ4/A,R1/A,SD/A,SDB1,SDB3/A,SE/A,SHW,SHW/A,SNC1,SNE1,SX/A,SXE4,SXE4/A,SXQ4,SXQ4/A,SXU,SXU/A,VDG2,VDG2/A,VH/A,VMX,VX/A,VXB/A,VXB7,VXB7/A,VXE/A,VXEB/A,VXQ4,VXQ4/A,VXQ7,VXQ7/A,VXU,VXU/A,VXU1,VXU1/A,WKD6,WKD6/A,WKT4,WKT4/A,WMK,W1/A
			1	-	-	3033266	HH,HX,LD,LH,LHE,LW,LX,LXZ,PX,QD,QDA,QE,QH,QHC,QHE,QT,QX,QXB,QXE,QXEB,RD,RH,RHE,RX,SD,SE,SH,SHE,SHEZ,SW,SWE,SX,SXB,SXE,SXEB,VH,VXVXB,VXE,VXEB,WH
			1	-	-	3411798	LDB3,SDB3
			-	(1)	-	3140235	L1,P1,Q1,R1,V1,W1

2

E-14
E-14-3
E-14-4

Ref. No.	Part No.	Description	Reqd. QTY			Serial No.	Parts catalogue code
			(1)	(2)	(3)		
5	16955-ZE1-000	JOINT, FUEL TANK	1	(1)	-	-----	ED3,ED4,ED4/A,ED5,ED5/A,ES,ES1,ES1/A,ES2,HH,HHQ4,HHQ4/A,HX,HX/A,HXQ4,HXQ4/A,LD,LDB1,LDB3,LH,LH/A,LHE,LHE4,LHE4/A,LHZ,LKS,LKS/A,LP,LP/A,LSS4,LT,LT/A,LW,LX,LX/A,LXQ4,LXQ4/A,LXZ,L1,L1/A,PX,PX/A,P1,QAB2,QAB2/A,QAQ4,QAR2,QAR2/A,QC12,QC12/A,QD,QD/A,QDA,QE,QE/A,QH,QH/A,QHC,QHE,QHP1,QHP1/A,QHQ4,QHQ4/A,QHZ,QKA2,QMH,QMH/A,QMX2,QP,QP/A,QT,QT/A,QTC2,QTC2/A,QX,QX/A,QXB,QXB7,QXB7/A,QXE,QXE/A,QXEB,QXE4,QXE4/A,QXQ4,QXQ4/A,QXU,QXU/A,Q1,Q1/A,RD,RD/A,RH,RHE,RHE4,RHQ4,RHQ4/A,RTB2,RTB2/A,RX,RX/A,RXQ4,RXQ4/A,R1,R1/A,SD,SD/A,SDB1,SDB3,SDB3/A,SE,SE/A,SH,SHE,SHEZ,SHW,SHW/A,SNC1,SNE1,SW,SWE,SX,SX/A,SXB,SXE,SXEB,SXE4,SXE4/A,SXQ4,SXQ4/A,SXU,SXU/A,VDG2,VDG2/A,VH,VH/A,VMX,VX,VX/A,VXB,VXB/A,VXB7,VXB7/A,VXE,VXE/A,VXEB,VXEB/A,VXQ4,VXQ4/A,VXQ7,VXQ7/A,VXU,VXU/A,VXU1,VXU1/A,V1,WH,WKD6,WKD6/A,WKT4,WKT4/A,WMK,W1,W1/A
9	17500-ZE2-811ZA	TANK ASSY., FUEL (GAUGE) *NH31*.....MCKINLEY WHITE	1	(1)	-	-----	LKS,L1,P1,Q1,R1,V1,W1
			1	(1)	-	-----	4583903 LKS/A,L1/A,Q1/A,R1/A,W1/A
			1	-	-	-----	4583903 SHW/A
	17500-ZE2-812ZA	*NH31*.....MCKINLEY WHITE	1	(1)	-	-----	4775184 LKS/A,L1/A,Q1/A,R1/A,SHW/A,W1/A
	17500-ZE2-813ZA	*NH31*.....MCKINLEY WHITE	1	(1)	-	-----	4775185 LKS/A,L1/A,Q1/A,R1/A,SHW/A,W1/A
10	17505-ZE2-013	GAUGE ASSY., FUEL	1	(1)	-	-----	LKS,LKS/A,L1,L1/A,P1,Q1,Q1/A,R1,R1/A,V1,W1,W1/A
			1	-	-	-----	4475052 SHW/A
11	17510-ZE2-010ZA	TANK COMP., FUEL *NH31*.....MCKINLEY WHITE	1	(1)	-	-----	ED3,ED4,ED5,ES,ES1,HH,HHQ4,HX,HXQ4,LD,LDB1,LDB3,LH,LHE,LHE4,LHZ,LP,LSS4,LT,LW,LX,LXQ4,LXZ,L1,PX,P1,QAB2,QAQ4,QAR2,QC12,QD,QDA,QE,QH,QHC,QHE,QHP1,QHQ4,QHZ,QKA2,QMH,QMX2,QP,QT,QTC2,QX,QXB,QXB7,QXE,QXEB,QXE4,QXQ4,QXU,Q1,RD,RH,RHE,RHE4,RHQ4,RTB2,RX,RXQ4,R1,SD,SDB1,SDB3,SE,SH,SHE,SHEZ,SHW,SNC1,SNE1,SW,SWE,SX,SXB,SXE,SXEB,SXE4,SXQ4,SXU,VDG2,VH,VMX,VX,VXB,VXB7,VXE,VXEB,VXQ4,VXQ7,VXU,VXU1,V1,WH,WKD6,WKT4,W1
			1	(1)	-	-----	4568628 ED4/A,ED5/A,ES1/A,HHQ4/A,HX/A,HXQ4/A,LH/A,LHE4/A,LP/A,LT/A,LX/A,LXQ4/A,L1/A,PX/A,QAB2/A,QAR2/A,QC12/A,QD/A,QE/A,QH/A,QHP1/A,QHQ4/A,QMH/A,QP/A,QT/A,QTC2/A,QX/A,QXB7/A,QXE/A,QXE4/A,QXQ4/A,QXU/A,Q1/A,RD/A,RHQ4/A,RTB2/A,RX/A,RXQ4/A,R1/A,SD/A,SDB3/A,SE/A,SX/A,SXE4/A,SXQ4/A,SXU/A,VDG2/A,VH/A,VX/A,VXB/A,VXB7/A,VXE/A,VXEB/A,VXQ4/A,VXQ7/A,VXU/A,VXU1/A,WKD6/A,WKT4/A,W1/A
			1	-	-	-----	4475051 SHW/A
	17510-ZE2-010ZD	*NH1*.....BLACK	1	-	-	-----	ED5,ES1,QAQ4,QMX2,QTC2,VXB7
			1	-	-	-----	4568628 ED5/A,ES1/A,PX/A,QTC2/A,SX/A,VXB7/A
	17510-ZE2-010ZE	*NH105*...MAT BLACK (#15-#20)	1	-	-	-----	VXB7,VXB7/A
	17510-ZE2-010ZF	*Y131*.....LIGHTNING YELLOW	1	-	-	-----	ES1
			1	-	-	-----	4568628 ES1/A
	17510-ZE2-010ZG	*T77*.....SEC WINE RED	1	-	-	-----	ES1
			1	-	-	-----	4568628 ES1/A
	17510-ZE2-020ZA	*NH31*.....MCKINLEY WHITE	1	(1)	-	-----	4568629 4776725 ED4/A,ED5/A,ES1/A,HHQ4/A,HX/A,HXQ4/A,LH/A,LHE4/A,LP/A,LT/A,LX/A,LXQ4/A,L1/A,PX/A,QAB2/A,QAR2/A,QC12/A,QD/A,QE/A,QH/A,QHP1/A,QHQ4/A,QMH/A,QP/A,QT/A,QTC2/A,QX/A,QXB7/A,QXE/A,QXE4/A,QXQ4/A,QXU/A,Q1/A,RD/A,RHQ4/A,RTB2/A,RX/A,RXQ4/A,R1/A,SD/A,SDB3/A,SE/A,SX/A,SXE4/A,SXQ4/A,SXU/A,VDG2/A,VH/A,VX/A,VXB/A,VXB7/A,VXE/A,VXEB/A,VXQ4/A,VXQ7/A,VXU/A,VXU1/A,WKD6/A,WKT4/A,W1/A
			1	-	-	-----	4568629 4776725 ED5/A,ES1/A,PX/A,QTC2/A,SX/A,VXB7/A
	17510-ZE2-020ZE	*NH105*...MAT BLACK (#15-#20)	1	-	-	-----	VXB7/A
	17510-ZE2-020ZF	*Y131*.....LIGHTNING YELLOW	1	-	-	-----	4568629 4776725 ES1/A
	17510-ZE2-020ZG	*T77*.....SEC WINE RED	1	-	-	-----	4568629 4776725 ES1/A
	17510-ZE2-800ZA	*NH1*.....BLACK	1	-	-	-----	4776726 ED5/A,PX/A,QTC2/A,SX/A,VXB7/A
			1	-	-	-----	4776726 4845181 ES1/A
	17510-ZE2-800ZB	*NH105*...MAT BLACK (#15-#20)	1	-	-	-----	4776726 VXB7/A



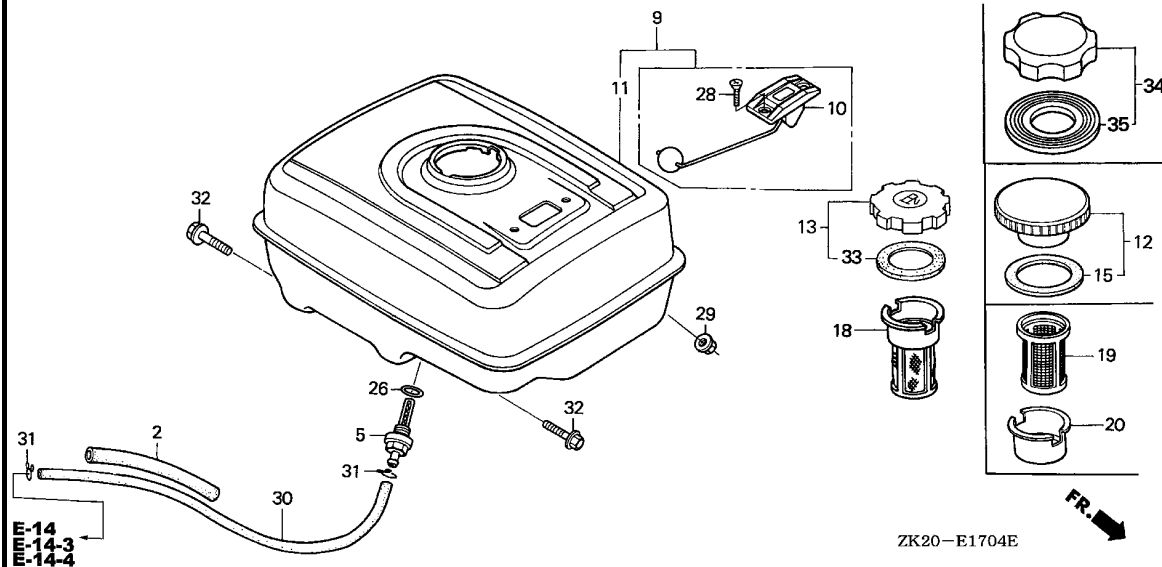

Ref. No.	Part No.	Description	Reqd. QTY			Serial No.	Parts catalogue code
			GX240K1				
			(1)	(2)	(3)		
11)	17510-ZE2-800ZC	TANK COMP., FUEL *NH31*.....MCKINLEY WHITE	1	(1)	-	4776726 4845181	ED5/A, ES1/A, HX/A, LH/A, LP/A, LT/A, LX/A, L1/A, PX/A, QD/A, QH/A, QHP1/A, QMH/A, QP/A, QT/A, QX/A, QXE/A, Q1/A, RD/A, RX/A, R1/A, SD/A, SDB3/A, SX/A, VH/A, VX/A, VXE/A, VXEB/A, VXU/A, W1/A
			1	-	-	4776726	ED4/A, HHQ4/A, HXQ4/A, LHE4/A, LXQ4/A, QAB2/A, QAR2/A, QC12/A, QE/A, QHQ4/A, QTC2/A, QXB7/A, QXE4/A, QXQ4/A, QXU/A, RHQ4/A, RTB2/A, RXQ4/A, SE/A, SXE4/A, SXQ4/A, SXU/A, VDG2/A, VXB/A, VXB7/A, VXQ4/A, VXQ7/A, VXU1/A, WKD6/A, WKT4/A
	17510-ZE2-800ZE	*T77*.....SEC WINE RED	1	-	-	4776726	ES1/A
	17510-ZE2-800ZF	*Y131*.....LIGHTNING YELLOW	1	-	-	4776726	ES1/A
	17510-ZE2-801ZA	*NH1*.....BLACK	1	-	-	-----	ES2
			1	-	-	4845182	ES1/A
	17510-ZE2-801ZC	*NH31*.....MCKINLEY WHITE	1	(1)	-	4845182	ED5/A, ES1/A, HX/A, LH/A, LP/A, LT/A, LX/A, L1/A, PX/A, QD/A, QH/A, QHP1/A, QMH/A, QP/A, QT/A, QX/A, QXE/A, Q1/A, RD/A, RX/A, R1/A, SD/A, SDB3/A, SX/A, VH/A, VX/A, VXE/A, VXEB/A, VXU/A, W1/A
			1	-	-	-----	ES2, WMK
	17510-ZE2-801ZD	*R280*.....POWER RED	1	-	-	-----	ES2
	17510-ZE2-801ZE	*T77*.....SEC WINE RED	1	-	-	-----	ES2
	17510-ZE2-801ZF	*Y131*.....LIGHTNING YELLOW	1	-	-	-----	ES2
12	17620-ZE2-W00	CAP COMP., FUEL FILLER (CHROME PLATED)	1	(1)	-	----- 3254423	ED3, ED4, ED5, ES, ES1, HH, HX, LD, LH, LHE, LKS, LP, LW, LX, LXZ, L1, PX, P1, QD, QDA, QE, QH, QHC, QHE, QP, QX, QXB, QXE, QXEB, Q1, RD, RH, RHE, RX, R1, SD, SE, SH, SHE, SHEZ, SW, SWE, SX, SXB, SXE, SXEB, VH, VX, VXB, VXE, VXEB, VXU, V1, WH, W1
			1	-	-	-----	LDB1, LDB3, LHZ, LT, QHZ, QT, SDB1, SDB3
			1	-	-	----- 4495553	LT/A, QT/A, SDB3/A

2

Ref. No.	Part No.	Description	Reqd. QTY			Serial No.	Parts catalogue code
			(1)	(2)	(3)		
13	17620-ZH7-023	CAP COMP., FUEL FILLER (BLACK)	1	(1)	-	3254424	ED3,ED4,ED5,ES,ES1,HH,HX,LD,LH,LHE,LKS,LP,LW,LX,LXZ,L1,PX,P1,QD,QDA,QE,QH,QHC,QHE,QP,QX,QXB,QXE,QXEB,Q1,RD,RH,RHE,RX,R1,SD,SE,SH,SHE,SHEZ,SW,SWE,SX,SXB,SXE,SXEB,VH,VX,VXB,VXE,VXEB,VXU,V1,WH,W1
			1	(1)	-	4495553	ED4/A,ED5/A,ES1/A,HHQ4/A,HX/A,HXQ4/A,LH/A,LHE4/A,LKS/A,LP/A,LX/A,LXQ4/A,L1/A,PX/A,QAB2/A,QAR2/A,QC12/A,QD/A,QE/A,QH/A,QHP1/A,QHQ4/A,QMH/A,QP/A,QTC2/A,QX/A,QXB7/A,QXE/A,QXE4/A,QXQ4/A,QXU/A,Q1/A,RD/A,RHQ4/A,RTB2/A,RX/A,RXQ4/A,R1/A,SD/A,SE/A,SHW/A,SX/A,SXE4/A,SXQ4/A,SXU/A,VDG2/A,VH/A,VX/A,VXB/A,VXB7/A,VXE/A,VXEB/A,VXQ4/A,VXQ7/A,VXU/A,VXU1/A,WKD6/A,WKT4/A,W1/A
			1	-	-		HHQ4,HXQ4,LHE4,LSS4,LXQ4,QAB2,QAQ4,QAR2,QC12,QHP1,QHQ4,QKA2,QMH,QMX2,QTC2,QXB7,QXE4,QXQ4,QXU,RHE4,RHQ4,RTB2,RXQ4,SHW,SNC1,SNE1,SXE4,SXQ4,SXU,VDG2,VMX,VXB7,VXQ4,VXQ7,VXU1,WKD6,WKT4
15	17631-329-003	PACKING, FUEL FILLER CAP (39X58X3)	1	(1)	-	3254423	ED3,ED4,ED5,ES,ES1,HH,HX,LD,LH,LHE,LKS,LP,LW,LX,LXZ,L1,PX,P1,QD,QDA,QE,QH,QHC,QHE,QP,QX,QXB,QXE,QXEB,Q1,RD,RH,RHE,RX,R1,SD,SE,SH,SHE,SHEZ,SW,SWE,SX,SXB,SXE,SXEB,VH,VX,VXB,VXE,VXEB,VXU,V1,WH,W1
			1	-	-		LDB1,LDB3,LHZ,LT,QHZ,QT,SDB1,SDB3
			1	-	-	4495553	LT/A,QT/A,SDB3/A
18	17672-ZE2-W01	FILTER, FUEL	1	(1)	-		ED4/A,ED5/A,ES1/A,ES2,LDB3,LKS/A,LP/A,LSS4,LT,LT/A,L1/A,QAB2,QAB2/A,QAQ4,QAR2,QAR2/A,QC12,QC12/A,QE/A,QKA2,QMX2,QP/A,QT/A,QTC2,QTC2/A,Q1/A,RTB2,RTB2/A,R1/A,SDB3,SDB3/A,SE/A,SNC1,VDG2,VDG2/A,WKD6,WKD6/A,WKT4,WKT4/A,W1/A
			1	(1)	-	3190916	ED3,ED4,ED5,ES,ES1,LP,LW,L1,P1,QE,QP,QT,Q1,R1,SE,SW,SWE,V1,W1
			1	-	-	3200766	LKS
19	17672-880-000	FILTER, FUEL	1	(1)	-	3118370	3190915 ED3,ES,ES1,LP,LW,L1,P1,QE,QP,QT,Q1,R1,SE,SW,SWE,V1,W1
			1	-	-		3190915 ED4,ED5
			1	-	-		3200765 LKS
20	17673-893-000	HOLDER, FUEL FILTER	1	1	-	3118370	3190915 ED3,ED4,ED5,ES,ES1,LP,LW,L1,P1,QE,QP,QT,Q1,R1,SE,SW,SWE,V1,W1
			1	-	-		3200765 LKS
26	91353-671-004	O-RING, 14MM(NOK)	1	(1)	-		ED3,ED4,ED4/A,ED5,ED5/A,ES,ES1,ES1/A,ES2,HH,HHQ4,HHQ4/A,HX,HX/A,HXQ4,HXQ4/A,LD,LDB1,LDB3,LH,LH/A,LHE,LHE4,LHE4/A,LHZ,LKS,LKS/A,LP,LP/A,LSS4,LT,LT/A,LW,LX,LX/A,LXQ4,LXQ4/A,LXZ,L1,L1/A,PX,PX/A,P1,QAB2,QAB2/A,QAQ4,QAR2,QAR2/A,QC12,QC12/A,QD,QD/A,QDA,QE,QE/A,QH,QH/A,QHC,QHE,QHP1,QHP1/A,QHQ4,QHQ4/A,QHZ,QKA2,QMH,QMH/A,QMX2,QP,QP/A,QT,QT/A,QTC2,QTC2/A,QX,QX/A,QXB,QXB7,QXB7/A,QXE,QXE/A,QXEB,QXE4,QXE4/A,QXQ4,QXQ4/A,QXU,QXU/A,Q1,Q1/A,RD,RD/A,RH,RHE,RHE4,RHQ4,RHQ4/A,RTB2,RTB2/A,RX,RX/A,RXQ4,RXQ4/A,R1,R1/A,SD,SD/A,SDB1,SDB3,SDB3/A,SE,SE/A,SH,SHE,SHEZ,SHW,SHW/A,SNC1,SNE1,SW,SWE,SX,SX/A,SXB,SXE,SXEB,SXE4,SXE4/A,SXQ4,SXQ4/A,SXU,SXU/A,VDG2,VDG2/A,VH,VH/A,VMX,VX,VX/A,VXB,VXB/A,VXB7,VXB7/A,VXE,VXE/A,VXEB,VXEB/A,VXQ4,VXQ4/A,VXQ7,VXQ7/A,VXU,VXU/A,VXU1,VXU1/A,V1,WH,WKD6,WKD6/A,WKT4,WKT4/A,WMK,W1,W1/A
28	93600-05010-0A	SCREW, FLAT, 5X10	2	(2)	-		LKS,LKS/A,L1,L1/A,P1,Q1,Q1/A,R1,R1/A,V1,W1,W1/A
			2	-	-	4475052	SHW/A

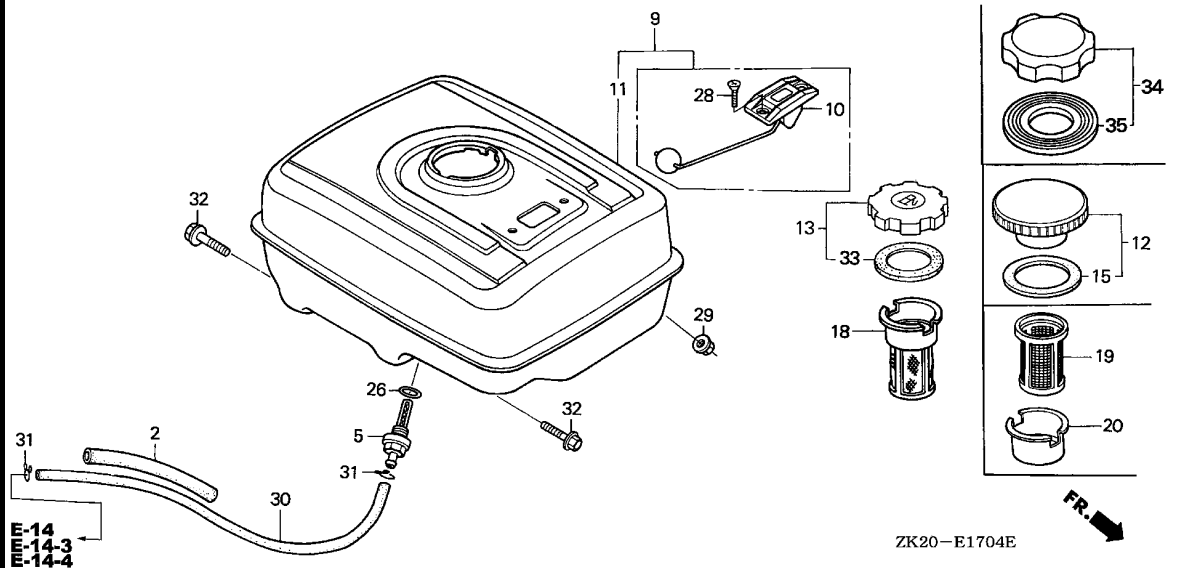

2

Ref. No.	Part No.	Description	Reqd. QTY			Serial No.	Parts catalogue code
			(1)	(2)	(3)		
29	94050-08000	NUT, FLANGE, 8MM	2	(2)	-	ED3,ED4,ED4/A,ED5,ED5/A,ES,ES1,ES1/A,ES2,HH,HHQ4,HHQ4/A,HX,HX/A,HXQ4,HXQ4/A,LD,LDB1,LDB3,LH,LH/A,LHE,LHE4,LHE4/A,LHZ,LKS,LKS/A,LP,LP/A,LSS4,LT,LT/A,LW,LX,LX/A,LXQ4,LXQ4/A,LXZ,L1,L1/A,PX,PX/A,P1,QAB2,QAB2/A,QAQ4,QAR2,QAR2/A,QC12,QC12/A,QD,QD/A,QDA,QE,QE/A,QH,QH/A,QHC,QHE,QHP1,QHP1/A,QHQ4,QHQ4/A,QHZ,QKA2,QMH,QMH/A,QMX2,QP,QP/A,QT,QT/A,QTC2,QTC2/A,QX,QX/A,QXB,QXB7,QXB7/A,QXE,QXE/A,QXEB,QXE4,QXE4/A,QXQ4,QXQ4/A,QXU,QXU/A,Q1,Q1/A,RD,RD/A,RH,RHE,RHE4,RHQ4,RHQ4/A,RTB2,RTB2/A,RX,RX/A,RXQ4,RXQ4/A,R1,R1/A,SD,SD/A,SDB1,SDB3,SDB3/A,SE,SE/A,SH,SHE,SHEZ,SHW,SHW/A,SNC1,SNE1,SW,SWE,SX,SX/A,SXB,SXE,SXEB,SXE4,SXE4/A,SXQ4,SXQ4/A,SXU,SXU/A,VDG2,VDG2/A,VH,VH/A,VMX,VX,VX/A,VXB,VXB/A,VXB7,VXB7/A,VXE,VXE/A,VXEB,VXEB/A,VXQ4,VXQ4/A,VXQ7,VXQ7/A,VXU,VXU/A,VXU1,VXU1/A,V1,WH,WKD6,WKD6/A,WKT4,WKT4/A,WMK,W1,W1/A	
30	95001-45222-40 (95001-45001-60M)	TUBE, FUEL, 4.5X222	1	(1)	-	ED3,ED4,ED4/A,ED5,ED5/A,ES,ES1,ES1/A,ES2,HH,HHQ4,HHQ4/A,HX,HX/A,HXQ4,HXQ4/A,LD,LDB1,LH,LH/A,LHE,LHE4,LHE4/A,LHZ,LKS,LP,LP/A,LSS4,LT,LT/A,LW,LX,LX/A,LXQ4,LXQ4/A,LXZ,L1,L1/A,PX,PX/A,P1,QAB2,QAB2/A,QAQ4,QAR2,QAR2/A,QC12,QC12/A,QD,QD/A,QDA,QE,QE/A,QH,QH/A,QHC,QHE,QHP1,QHP1/A,QHQ4,QHQ4/A,QHZ,QKA2,QMH,QMH/A,QMX2,QP,QP/A,QT,QT/A,QTC2,QTC2/A,QX,QX/A,QXB,QXB7,QXB7/A,QXE,QXE/A,QXEB,QXE4,QXE4/A,QXQ4,QXQ4/A,QXU,QXU/A,Q1,Q1/A,RD,RD/A,RH,RHE,RHE4,RHQ4,RHQ4/A,RTB2,RTB2/A,RX,RX/A,RXQ4,RXQ4/A,R1,R1/A,SD,SD/A,SDB1,SDB3/A,SE,SE/A,SH,SHE,SHEZ,SHW,SHW/A,SNC1,SNE1,SW,SWE,SX,SX/A,SXB,SXE,SXEB,SXE4,SXE4/A,SXQ4,SXQ4/A,SXU,SXU/A,VDG2,VDG2/A,VH,VH/A,VMX,VX,VX/A,VXB,VXB/A,VXB7,VXB7/A,VXE,VXE/A,VXEB,VXEB/A,VXQ4,VXQ4/A,VXQ7,VXQ7/A,VXU,VXU/A,VXU1,VXU1/A,V1,WH,WKD6,WKD6/A,WKT4,WKT4/A,WMK,W1,W1/A	
			1	-	-	3411798 LDB3,SDB3	

Ref. No.	Part No.	Description	Reqd. QTY			Serial No.	Parts catalogue code
			(1)	(2)	(3)		
31	95002-02080	CLIP, TUBE (B8)	2	(2)	-	-----	ED3,ED4,ED4/A,ED5,ED5/A,ES,ES1,ES1/A,ES2,HH,HHQ4,HHQ4/A,HX,HX/A,HXQ4,HXQ4/A,LD,LDB1,LDB3,LH,LH/A,LHE,LHE4,LHE4/A,LHZ,LKS,LP,LP/A,LSS4,LT,LT/A,LW,LX,LX/A,LXQ4,LXQ4/A,LXZ,L1,L1/A,PX,PX/A,P1,QAB2,QAB2/A,QAQ4,QAR2,QAR2/A,QC12,QC12/A,QD,QD/A,QDA,QE,QE/A,QH,QH/A,QHC,QHE,QHP1,QHP1/A,QHQ4,QHQ4/A,QHZ,QKA2,QMH,QMH/A,QMX2,QP,QP/A,QT,QT/A,QTC2,QTC2/A,QX,QX/A,QXB,QXB7,QXB7/A,QXE,QXE/A,QXE4,QXE4/A,QXQ4,QXQ4/A,QXU,QXU/A,Q1,Q1/A,RD,RD/A,RH,RHE,RHE4,RHQ4,RHQ4/A,RTB2,RTB2/A,RX,RX/A,RXQ4,RXQ4/A,R1,R1/A,SD,SD/A,SDB1,SDB3,SDB3/A,SE,SE/A,SH,SHE,SHEZ,SHW,SHW/A,SNC1,SNE1,SW,SWE,SX,SX/A,SXB,SXE,SXE4,SXE4/A,SXQ4,SXQ4/A,SXU,SXU/A,VDG2,VDG2/A,VH,VH/A,VMX,VX,VX/A,VXB,VXB/A,VXB7,VXB7/A,VXE,VXE/A,VXEB,VXEB/A,VXQ4,VXQ4/A,VXQ7,VXQ7/A,VXU,VXU/A,VXU1,VXU1/A,V1,WH,WKD6,WKD6/A,WKT4,WKT4/A,WMK,W1,W1/A
32	95701-08025-00	BOLT, FLANGE, 8X25	2	(2)	-	-----	ED3,ED4,ED4/A,ED5,ED5/A,ES,ES1,ES1/A,ES2,HH,HHQ4,HHQ4/A,HX,HX/A,HXQ4,HXQ4/A,LD,LDB1,LDB3,LH,LH/A,LHE,LHE4,LHE4/A,LHZ,LKS,LKS/A,LP,LP/A,LSS4,LT,LT/A,LW,LX,LX/A,LXQ4,LXQ4/A,LXZ,L1,L1/A,PX,PX/A,P1,QAB2,QAB2/A,QAQ4,QAR2,QAR2/A,QC12,QC12/A,QD,QD/A,QDA,QE,QE/A,QH,QH/A,QHC,QHE,QHP1,QHP1/A,QHQ4,QHQ4/A,QHZ,QKA2,QMH,QMH/A,QMX2,QP,QP/A,QT,QT/A,QTC2,QTC2/A,QX,QX/A,QXB,QXB7,QXB7/A,QXE,QXE/A,QXE4,QXE4/A,QXQ4,QXQ4/A,QXU,QXU/A,Q1,Q1/A,RD,RD/A,RH,RHE,RHE4,RHQ4,RHQ4/A,RTB2,RTB2/A,RX,RX/A,RXQ4,RXQ4/A,R1,R1/A,SD,SD/A,SDB1,SDB3,SDB3/A,SE,SE/A,SH,SHE,SHEZ,SHW,SHW/A,SNC1,SNE1,SW,SWE,SX,SX/A,SXB,SXE,SXE4,SXE4/A,SXQ4,SXQ4/A,SXU,SXU/A,VDG2,VDG2/A,VH,VH/A,VMX,VX,VX/A,VXB,VXB/A,VXB7,VXB7/A,VXE,VXE/A,VXEB,VXEB/A,VXQ4,VXQ4/A,VXQ7,VXQ7/A,VXU,VXU/A,VXU1,VXU1/A,V1,WH,WKD6,WKD6/A,WKT4,WKT4/A,WMK,W1,W1/A
33	17631-ZH7-003	PACKING, FUEL FILLER CAP (39X58X3)	1	(1)	-	3254424 -----	ED3,ED4,ED5,ES,ES1,HH,HX,LD,LH,LHE,LKS,LP,LW,LX,LXZ,L1,PX,P1,QD,QDA,QE,QH,QHC,QHE,QP,QX,QXB,QXE,QXE4,Q1,RD,RH,RHE,RX,R1,SD,SE,SH,SHE,SHEZ,SW,SWE,SX,SXB,SXE,SXE4,SXE4/A,SXQ4,SXQ4/A,SXU,SXU/A,VDG2,VDG2/A,VH,VH/A,VMX,VX,VX/A,VXB,VXB/A,VXB7,VXB7/A,VXE,VXE/A,VXEB,VXEB/A,VXQ4,VXQ4/A,VXQ7,VXQ7/A,VXU,VXU/A,WKD6/A,WKT4/A,W1/A
			1	(1)	-	-----	4495553 ED4/A,ED5/A,ES1/A,HHQ4/A,HX/A,HXQ4/A,LH/A,LHE4/A,LKS/A,LP/A,LX/A,LXQ4/A,L1/A,PX/A,QAB2/A,QAR2/A,QC12/A,QD/A,QE/A,QH/A,QHP1/A,QHQ4/A,QMH/A,QP/A,QTC2/A,QX/A,QXB7/A,QXE/A,QXE4/A,QXQ4/A,QXU/A,Q1/A,RD/A,RHQ4/A,RTB2/A,RX/A,RXQ4/A,R1/A,SD/A,SE/A,SHW/A,SX/A,SXE4/A,SXQ4/A,SXU/A,VDG2/A,VH/A,VX/A,VXB/A,VXB7/A,VXE/A,VXEB/A,VXQ4/A,VXQ7/A,VXU/A,VXU1/A,WKD6/A,WKT4/A,W1/A
			1	-	-	-----	HHQ4,HHQ4,LHE4,LSS4,LXQ4,QAB2,QAQ4,QAR2,QC12,QHP1,QHQ4,QKA2,QMH,QMX2,QTC2,QXB7,QXE4,QXQ4,QXU,RHE4,RHQ4,RTB2,RXQ4,SHW,SNC1,SNE1,SXE4,SXQ4,SXU,VDG2,VMX,VXB7,VXQ4,VXQ7,VXU1,WKD6,WKT4
34	17620-Z0T-305	CAP COMP., FUEL FILLER (CHROME PLATED)	1	(1)	-	4495554 -----	ED4/A,ED5/A,ES1/A,HHQ4/A,HX/A,HXQ4/A,LH/A,LHE4/A,LKS/A,LP/A,LT/A,LX/A,LXQ4/A,L1/A,PX/A,QAB2/A,QAR2/A,QC12/A,QD/A,QE/A,QH/A,QHP1/A,QHQ4/A,QMH/A,QP/A,QT/A,QTC2/A,QX/A,QXB7/A,QXE/A,QXE4/A,QXQ4/A,QXU/A,Q1/A,RD/A,RHQ4/A,RTB2/A,RX/A,RXQ4/A,R1/A,SD/A,SDB3/A,SE/A,SHW/A,SX/A,SXE4/A,SXQ4/A,SXU/A,VDG2/A,VH/A,VX/A,VXB/A,VXB7/A,VXE/A,VXEB/A,VXQ4/A,VXQ7/A,VXU/A,VXU1/A,WKD6/A,WKT4/A,W1/A
			1	-	-	-----	ES2,WMK
35	17631-Z0T-812	PACKING, FUEL FILLER CAP (39X62X3)	1	(1)	-	4495554 -----	ED4/A,ED5/A,ES1/A,HHQ4/A,HX/A,HXQ4/A,LH/A,LHE4/A,LKS/A,LP/A,LT/A,LX/A,LXQ4/A,L1/A,PX/A,QAB2/A,QAR2/A,QC12/A,QD/A,QE/A,QH/A,QHP1/A,QHQ4/A,QMH/A,QP/A,QT/A,QTC2/A,QX/A,QXB7/A,QXE/A,QXE4/A,QXQ4/A,QXU/A,Q1/A,RD/A,RHQ4/A,RTB2/A,RX/A,RXQ4/A,R1/A,SD/A,SDB3/A,SE/A,SHW/A,SX/A,SXE4/A,SXQ4/A,SXU/A,VDG2/A,VH/A,VX/A,VXB/A,VXB7/A,VXE/A,VXEB/A,VXQ4/A,VXQ7/A,VXU/A,VXU1/A,WKD6/A,WKT4/A,W1/A
			1	-	-	-----	ES2,WMK



E-17-5

FUEL TANK(6)

2-B 3

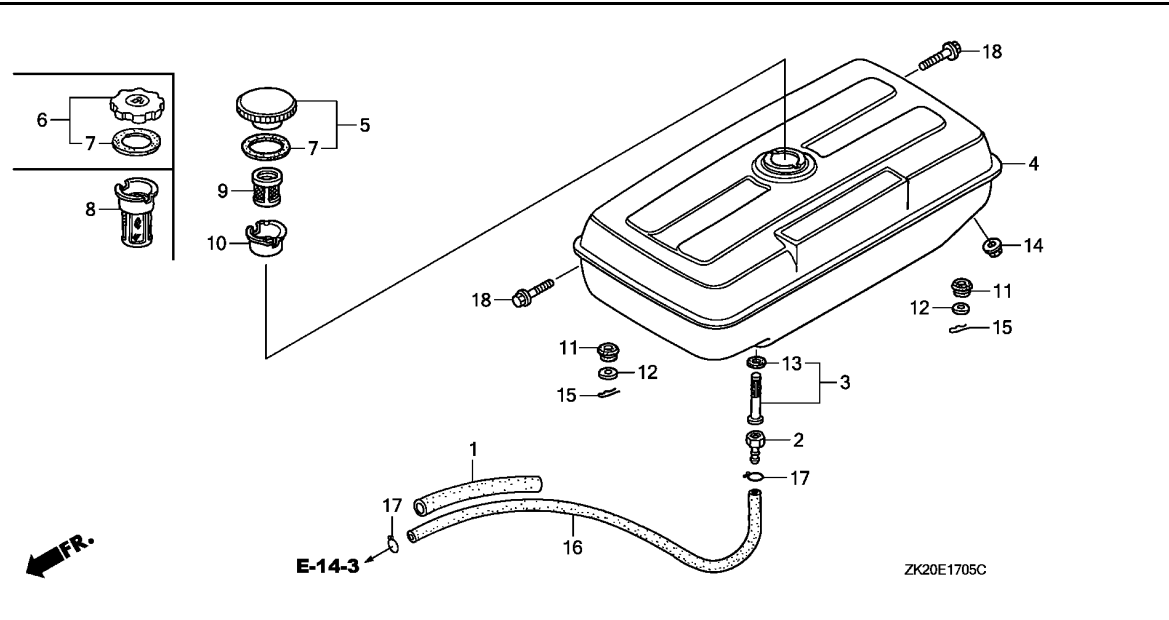

Ref. No.	L.O.N.	(Relative ref. Number) Description	F.R.T.
3		(13)	
3	3101H6	JOINT, FUEL STRAINER	0.2
4	3101D0	TANK, FUEL(A)	0.2
8		(9)	
8	3101A6	FILTER, FUEL	0.1
11	3101K1	RUBBER, TANK CUSHION	0.1
16	3101B7	HOSE, FUEL TANK	0.2

Ref. No.	Part No.	Description	Reqd. QTY			Serial No.	Parts catalogue code
			(1)	(2)	(3)		
			GX240K1				
1	16854-ZH8-000	RUBBER, SUPPORTER (107MM) ...	1	-	-	-----	EN,ET,ETS,ETX
2	16950-732-000	JOINT, FUEL	1	-	-	-----	EN,ET,ETS,ETX
3	16952-883-005	SCREEN SET	1	-	-	-----	EN,ET,ETS,ETX
4	17510-893-000ZB	TANK COMP., FUEL					
5	17620-ZE2-W00	*R8*.....BRIGHT RED CAP COMP., FUEL FILLER (CHROME PLATED)	1	-	-	-----	EN,ET,ETS,ETX
6	17620-ZH7-023	CAP COMP., FUEL FILLER (BLACK)	1	-	-	3254424	----- EN,ET,ETS,ETX
7	17631-329-003	PACKING, FUEL FILLER CAP (39X58X3)	1	-	-	-----	3254423 EN,ET,ETS,ETX
	17631-ZH7-003	1	-	-	3254424	----- EN,ET,ETS,ETX
8	17672-ZE2-W01	FILTER, FUEL	1	-	-	3190917	----- EN,ET,ETS,ETX
9	17672-880-000	FILTER, FUEL	1	-	-	-----	3190916 EN,ET,ETS,ETX
10	17673-893-000	HOLDER, FUEL FILTER	1	-	-	-----	3190916 EN,ET,ETS,ETX
11	17682-817-020	RUBBER, TANK CUSHION	4	-	-	-----	EN,ET,ETS,ETX
12	90506-500-000	WASHER, AIR DUCT	4	-	-	-----	EN,ET,ETS,ETX
13	91353-671-004	O-RING, 14MM(NOK)	1	-	-	-----	3314698 EN,ET,ETS,ETX
14	94050-08000	NUT, FLANGE, 8MM	2	-	-	-----	3314698 EN,ET,ETS,ETX
15	94251-08000	PIN, LOCK, 8MM	4	-	-	-----	EN,ET,ETS,ETX
16	95001-45430-40	TUBE, FUEL, 4.5X430 (95001-45001-60M)	1	-	-	-----	EN,ET,ETS,ETX
17	95002-02080	CLIP, TUBE (B8)	2	-	-	-----	EN,ET,ETS,ETX
18	95701-08025-00	BOLT, FLANGE, 8X25	2	-	-	-----	3314698 EN,ET,ETS,ETX

2

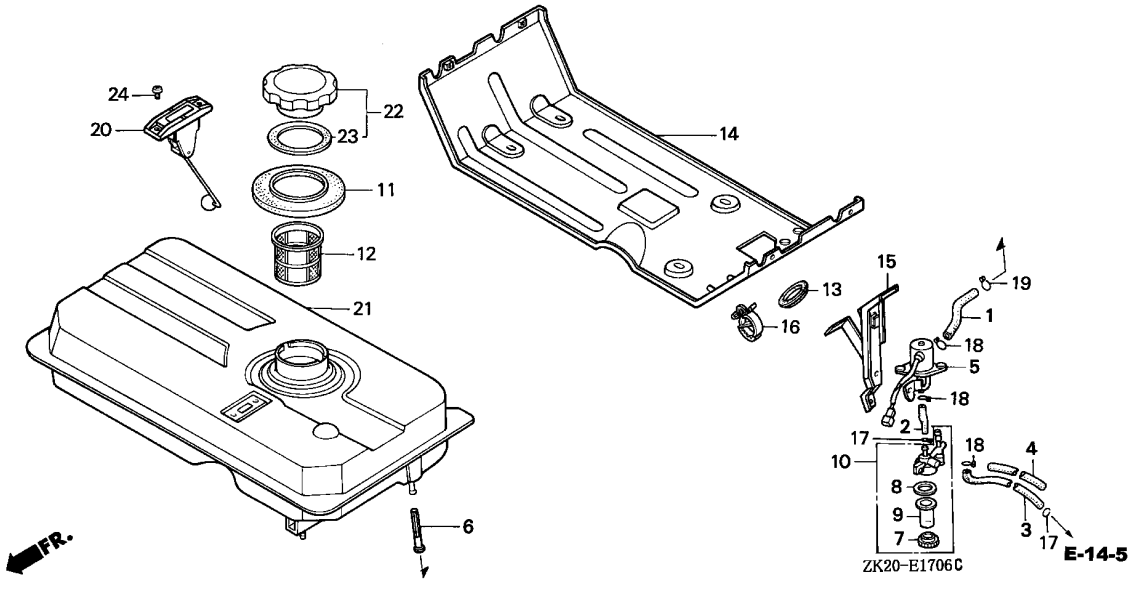

Ref. No.	L.O.N.	(Relative ref. Number) Description	F.R.T.
1	3101F2	TUBE, FUEL COCK	0.2
3	3101F6	TUBE, FUEL	0.2
5	3101H0	VALVE, ELECTRIC FUEL	0.2
6	3101K6	STRAINER, FUEL(A)	0.2
10	3101F4	CUP, FUEL STRAINER	0.2
12	3101A6	FILTER, FUEL	0.1
14	4141J4	PLATE, FUEL TANK HANGER	0.2
20	6171A1	METER/GAUGE UNIT, FUEL	0.1
21	3101D0	TANK, FUEL(A)	0.2

Ref. No.	Part No.	Description	Reqd. QTY			Serial No.	Parts catalogue code
			(1)	(2)	(3)		
			GX240K1				
1	16851-ZB7-000	TUBE, FUEL (TANK-COCK)	1	-	-	-----	EDS5
2	16852-ZB7-000	TUBE, FUEL (COCK-STRAINER) ..	1	-	-	-----	EDS5
3	16853-ZB7-000	TUBE, FUEL (STRAINER-CARBURETOR)	1	-	-	-----	EDS5
4	16857-ZB7-000	TUBE, FUEL SUPPORTER	1	-	-	-----	EDS5
5	16930-ZB7-013	COCK ASSY., ELECTRIC FUEL ...	1	-	-	-----	EDS5
6	16952-ZB7-000	STRAINER, FUEL	1	-	-	-----	EDS5
7	16957-707-005	NUT, RING	1	-	-	-----	EDS5
8	16963-443-901	GASKET	1	-	-	-----	EDS5
9	16967-196-005	CUP, FUEL STRAINER	1	-	-	-----	EDS5
10	16990-ZB7-005	CUP ASSY., FUEL STRAINER	1	-	-	-----	EDS5
11	17520-ZA0-800	SEAL, FUEL FILLER NECK	1	-	-	-----	EDS5
12	17672-899-000	FILTER, FUEL	1	-	-	-----	EDS5
13	32112-611-000	GROMMET, WIRE CORD	1	-	-	-----	EDS5
14	63125-ZB7-000	PLATE, FUEL TANK HANGER	1	-	-	-----	EDS5
15	63132-ZB7-000	BRACKET, STRAINER CUP SETTING	1	-	-	-----	EDS5
16	90684-ZA0-601	CLIP, HARNESS	1	-	-	-----	EDS5
17	95002-02080	CLIP, TUBE (B8)	2	-	-	-----	EDS5
18	95002-02100	CLIP, TUBE (B10)	3	-	-	-----	EDS5
19	95002-02120	CLIP, TUBE (B12)	1	-	-	-----	EDS5
20	17505-ZB2-003	METER ASSY., FUEL	1	-	-	-----	EDS5
21	17510-ZB7-000	TANK COMP., FUEL	1	-	-	-----	EDS5
22	17620-899-013	CAP COMP., FUEL FILLER	1	-	-	-----	EDS5
23	17631-899-000	PACKING, FUEL FILLER CAP	1	-	-	-----	EDS5
24	93600-05010-0A	SCREW, FLAT, 5X10	2	-	-	-----	EDS5



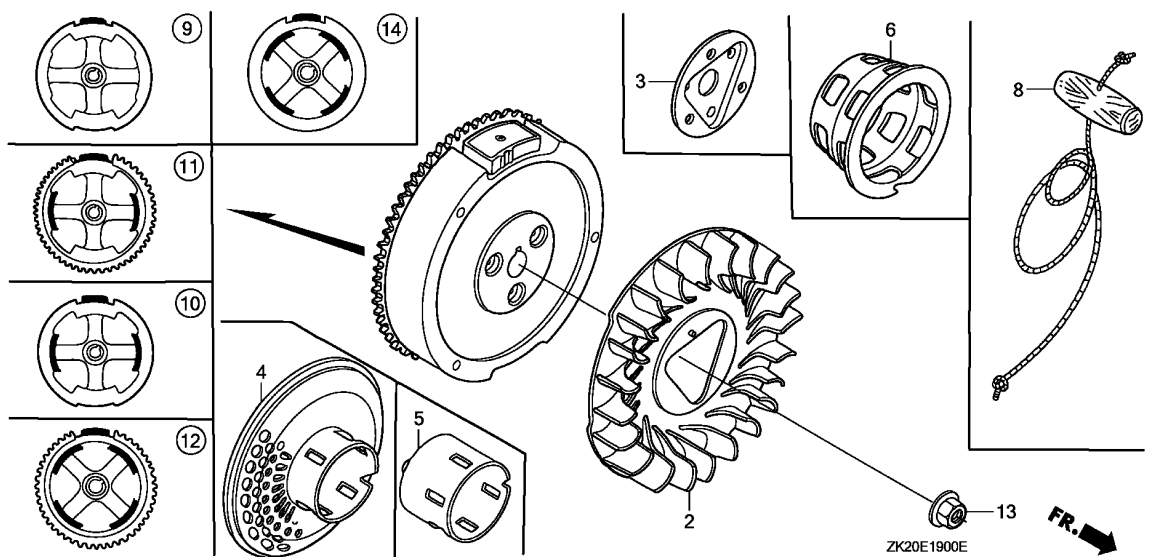

Ref. No.	L.O.N.	(Relative ref. Number) Description	F.R.T.
2	1141G7	FAN, ENGINE COOLING	0.2
4		(3,5,6)	
	1121A9	PULLEY, RECOIL STARTER	0.2
8	1121B3	ROPE, RECOIL STARTER	0.3
9		(10,11,12,14)	
	2161B5	FLYWHEEL	0.3



Ref. No.	Part No.	Description	Reqd. QTY			Serial No.	Parts catalogue code
			(1)	(2)	(3)		
2	19511-ZE2-000	FAN, COOLING	1	1	1		
	19511-ZE3-000	(COSMOTEC/COMPRESSOR	1	-	-		SJC1,SJC1/A,SJC5,SJC5/A
		PLATE, COOLING FAN SETTING	1	-	-		SJC
3	19512-ZE2-000	PLATE, COOLING FAN SETTING	1	-	-		EDS5,LKS,LKS/A,LNJ,SHW,SHW/A
4	28450-ZE2-W11	PULLEY COMP., STARTER (SCREEN GRID)	1	-	-		HA,HAQ,HA2,HA2/A,HH,HHQ4,HHQ4/A,HTX,HX,HX/A,HXQ4,HXQ4/A,LH,LH/A,LHE,LHE4,LHE4/A,LHZ,LJS,LJS/A,LP,LP/A,LSS4,LSX,LSX/A,LT,LT/A,LW,LX,LX/A,LXF,LXQ4,LXQ4/A,LXZ,LX2,LX2/A,PA,PAE,PA2,PA2/A,PMT2,PMT2/A,PX,PX/A,QA,QAB2,QAB2/A,QAE,QAE2,QAE2/A,QAG2,QAG2/A,QAQ,QAQ4,QAR2,QAR2/A,QA2,QA2/A,QC12,QC12/A,QE,QE/A,QH,QH/A,QHB2,QHC,QHE,QHP1,QHP1/A,QHQ4,QHQ4/A,QHZ,QKA2,QMH,QMH/A,QP,QP/A,QW24,QX,QX/A,QXB,QXB7,QXB7/A,QXC,QXC/A,QXC9,QXC9/A,QXE,QXE/A,QXEB,QXE4,QXE4/A,QXQ4,QXQ4/A,QXU,QXU/A,RA,RA2,RA2/A,RH,RHE,RHE4,RHQ4,RHQ4/A,RSC2,RTB2,RTB2/A,RX,RX/A,RXQ4,RXQ4/A,SE,SE/A,SH,SHE,SHEZ,SNE1,SW,SWE,SX,SX/A,SXB,SXE,SXEB,SXE4,SXE4/A,SXQ4,SXQ4/A,SXU,SXU/A,VA,VAH1,VA2,VA2/A,VH,VH/A,VH12,VH12/A,VMX,VTA,VTA2,VTA2/A,VX,VX/A,VXB,VXB/A,VXB7,VXB7/A,VXE,VXE/A,VXEB,VXEB/A,VXQ4,VXQ4/A,VXQ7,VXQ7/A,VXU,VXU/A,VXU1,VXU1/A,WH
5	28451-ZE2-W01	PULLEY, STARTER	-	(1)	-		EDN,EDN2,EDN2/A,EDS,EDS1,EDS1/A,EDS2,EDS2/A,EDS3,EDS6,EDS6/A,EDT1,EDT1/A,EDT2,EDT3,EDT6,EDT6/A,ED2,ED2/A,ED3,ED4,ED4/A,ED5,ED5/A,EN,EN2,EN2/A,ES,ES1,ES1/A,ES2,ES3,ES3/A,ET,ETS,ETX,LD,LDB1,LDB3,LJ,LJ/A,LJG,LJG/A,LJG1,LK,LNZ,LSS5,LSS5/A,QAG,QAG/A,QD,QD/A,QDA,QMX2,QT,QT/A,QTC2,QTC2/A,RD,RD/A,RJ,RJ/A,RSS1,RSS1/A,SD,SD/A,SDB1,SDB3,SDB3/A,SJ,SJ/A,SJC,SJC1,SJC1/A,SJC5,SJC5/A,SJG,SJG/A,SJP,SK,SMS,SMS/A,SMX2,SMX2/A,SNC1,SNR,SNR/A,STP,STP/A,STQ,STQ/A,VDG2,VDG2/A,VMT2,VNG,VSB1,VSB1/A,VS3,VS4,VTE2,VWC2,VWC2/A,WJ,WJ/A,WKA,WKD6,WKD6/A,WKT2,WKT2/A,WKT4,WKT4/A,WMK
			-	(1)	1		

Ref. No.	Part No.	Description	Reqd. QTY			Serial No.	Parts catalogue code
			(1)	(2)	(3)		
6	28451-ZE3-A02	PULLEY, STARTER	1	-	-	LM9	
8	28470-816-000	ROPE, STARTER	-	(1)	-	L1, Q1, R1, S1, W1	
9	31100-ZE2-010	FLYWHEEL COMP.	1	-	-	EDT1, EDT1/A, EDT2, EDT3, EDT6, EDT6/A, ED4, ED4/A, ED5, ED5/A, EN, ES, ES1, ES1/A, ES2, ES3, ES3/A, ET, ETX, HA, HAQ, HA2, HA2/A, HH, HHQ4, HHQ4/A, HTX, HX, HX/A, HXQ4, HXQ4/A, LD, LDB1, LDB3, LH, LH/A, LHZ, LJ, LJ/A, LJG, LJG/A, LJG1, LJS, LJS/A, LK, LM9, LP, LP/A, LSS4, LSX, LSX/A, LX, LX/A, LXF, LXQ4, LXQ4/A, LXZ, LX2, LX2/A, PA, PA2, PA2/A, PMT2, PMT2/A, PX, PX/A, QA, QAB2, QAB2/A, QAG, QAG/A, QAQ, QAQ4, QA2, QA2/A, QC12, QC12/A, QD, QD/A, QDA, QE, QE/A, QH, QH/A, QHB2, QHC, QHP1, QHP1/A, QHQ4, QHQ4/A, QHZ, QMH, QMH/A, QMX2, QT, QT/A, QTC2, QTC2/A, QW24, QX, QX/A, QXB, QXB7, QXB7/A, QXC, QXC/A, QXC9, QXC9/A, QXQ4, QXQ4/A, QXU, QXU/A, RA, RA2, RA2/A, RD, RD/A, RH, RHQ4, RHQ4/A, RJ, RJ/A, RTB2, RTB2/A, RX, RX/A, RXQ4, RXQ4/A, SD, SD/A, SDB1, SDB3, SDB3/A, SE, SE/A, SH, SJ, SJ/A, SJC, SJC1, SJC1/A, SJC5, SJC5/A, SJG, SJG/A, SJP, SK, SMS, SMS/A, SMX2, SMX2/A, SNR, SNR/A, STP, STP/A, STQ, STQ/A, SX, SX/A, SXB, SXQ4, SXQ4/A, SXU, SXU/A, VA, VAH1, VA2, VA2/A, VDG2, VDG2/A, VH, VH/A, VH12, VH12/A, VMT2, VMX, VNG, VSB1, VSB1/A, VS3, VS4, VTA, VTA2, VTA2/A, VWC2, VWC2/A, VX, VX/A, VXB, VXB/A, VXB7, VXB7/A, VXQ4, VXQ4/A, VXQ7, VXQ7/A, VXU, VXU/A, VXU1, VXU1/A, WH, WJ, WJ/A, WKD6, WKD6/A, WKT2, WKT2/A, WKT4, WKT4/A, WMK	
			1	-	-	3337056	ED2
10	31100-ZE2-812	FLYWHEEL COMP. (LAMP)	1	-	-	EDN, EDN2, EDN2/A, LT, LT/A, LW, QAG2, QAG2/A, QP, QP/A, RSC2, SNC1, SW	
11	31100-ZE2-822	FLYWHEEL COMP. (STARTER MOTOR)	1	-	-	EDS, EDS1, EDS1/A, EDS2, EDS2/A, EDS3, EDS5, EDS6, EDS6/A, ED3, ETS, LHE, LHE4, LHE4/A, LNJ, LN2, QHE, QXE, QXE/A, QXEB, QXE4, QXE4/A, RHE, RHE4, RSS1, RSS1/A, SHE, SHEZ, SWE, SXE, SXEB, SXE4, SXE4/A, VXE, VXE/A, VXEB, VXEB/A, WKA	
12	31100-ZE2-W11	FLYWHEEL COMP. (SEL-18A)	-	(1)	-	QAR2, QAR2/A	
	31100-ZE2-832	FLYWHEEL COMP. (4POLE)	1	-	-	ED2, ED2/A, EN2, EN2/A, LKS, LKS/A, LSS5, LSS5/A, PAE, QAE, QAE2, QAE2/A, QKA2, SHW, SHW/A, SNE1, VTE2	
13	90201-ZE3-790	NUT, SPECIAL, 16MM	1	1	-	3467138 EDN, EDN2, EDS, EDS1, EDS3, EDS5, EDT1, ED2, ED3, ED4, ED5, EN, ES, ES1, ES3, ET, ETS, ETX, HA, HAQ, HA2, HH, HHQ4, HTX, HX, HXQ4, LD, LDB1, LDB3, LH, LHE, LHE4, LJ, LJG, LK, LKS, LM9, LN2, LN2, LP, LW, LX, LXQ4, LXZ, LX2, L1, PA, PAE, PA2, PMT2, PX, P1, QA, QAE, QAE2, QAG2, QAG2, QAG2, QAG2, QAR2, QA2, QD, QE, QH, QHC, QHE, QHQ4, QKA2, QP, QT, QX, QXB, QXC, QXC9, QXE, QXEB, QXE4, QXQ4, Q1, RA, RA2, RD, RH, RHE, RHE4, RHQ4, RJ, RSC2, RTB2, RX, RXQ4, R1, SD, SDB1, SDB3, SE, SH, SHE, SHEZ, SJ, SJC, SJG, SJP, SK, SMS, SMX2, SNC1, SNE1, SNR, STP, STQ, SW, SWE, SX, SXB, SXE, SXEB, SXE4, SXQ4, S1, VA, VAH1, VA2, VH, VH12, VNG, VTA, VWC2, VX, VXB, VXE, VXEB, VXQ4, VXU, V1, WH, WJ, WKA, WKT2, W1	
			1	-	-	QDA	
			-	-	1	1000005	VXP, VXQP



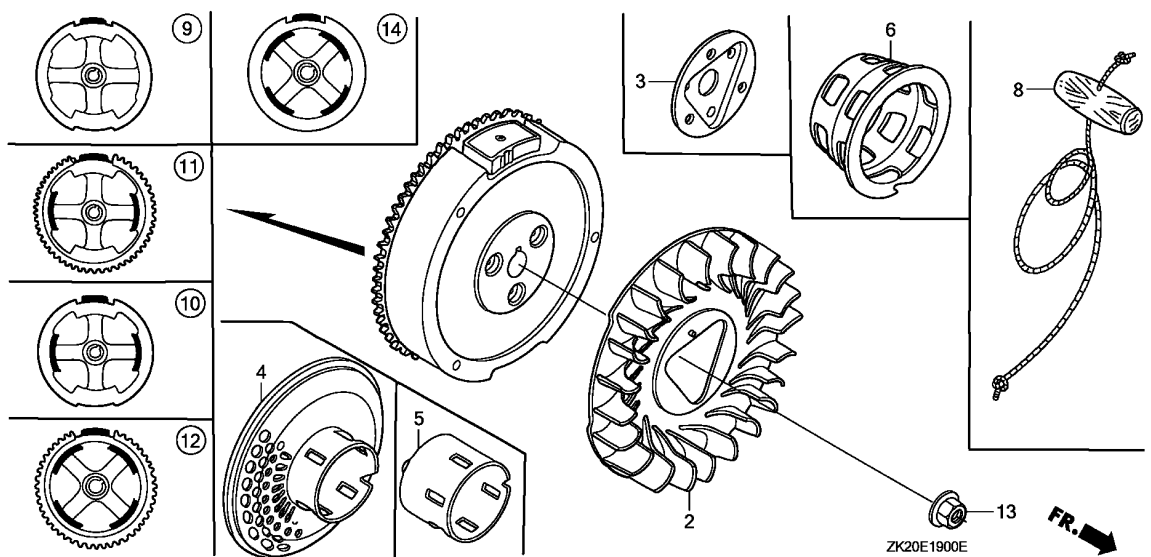

Ref. No.	Part No.	Description	Reqd. QTY			Serial No.	Parts catalogue code
			(1)	(2)	(3)		
13)	90201-ZE3-V00	NUT, SPECIAL, 16MM	1	1	-	3467139	EDN,EDN2,EDS,EDS1,EDS3,EDS5,EDT1,ED2,ED3,ED4,ED5,EN,ES,ES1,ES3,ET ETS,ETX,HA,HAQ,HA2,HH,HHQ4,HTX,HX,HXQ4,LD,LDB1,LDB3,LH,LHE,LHE4 LJ,LJG,LK,LKS,LM9,LNJ,LNZ,LP,LW,LX,LXQ4,LXZ,LX2,L1,PA,PAE,PA2 PMT2,PX,P1,QA,QAE,QAE2,QAG2,QAQ,QAQ4,QAR2,QA2,QD,QE,QH,QHC,QHE QHQ4,QKA2,QP,QT,QX,QXB,QXC,QXC9,QXE,QXEB,QXE4,QXQ4,Q1,RA,RA2,RD RH,RHE,RHE4,RHQ4,RJ,RSC2,RTB2,RX,RXQ4,R1,SD,SDB1,SDB3,SE,SH,SHE SHEZ,SJ,SJC,SJG,SJP,SK,SMS,SMX2,SNC1,SNE1,SNR,STP,STQ,SW,SWE,SX SXB,SXE,SXEB,SXE4,SXQ4,S1,VA,VAH1,VA2,VH,VH12,VNG,VTA,VWC2,VX,VXB VXE,VXEB,VXQ4,VXU,V1,WH,WJ,WKA,WKT2,W1
			1	1	-	4835165	EDS1/A,EDT1/A,ED5/A,ES1/A,ES3/A,HX/A,LH/A,LJ/A,LJG/A,LKS/A,LP/A LSX/A,LT/A,LX/A,LXF,L1/A,PX/A,QD/A,QH/A,QHP1/A,QMH/A,QP/A,QT/A QX/A,QXC/A,QXE/A,Q1/A,RD/A,RJ/A,RSS1/A,RX/A,R1/A,SD/A,SDB3/A SHW/A,SJ/A,SJC1/A,SJC5/A,SJG/A,SMS/A,SNR/A,STP/A,SX/A,S1/A,VH/A VSB1/A,VS3,VX/A,VXE/A,VXEB/A,VXU/A,WJ/A,W1/A
			1	-	1		EDN2/A,EDS2,EDS2/A,EDS6,EDS6/A,EDT2,EDT6,EDT6/A,ED2/A,ED4/A,EN2 EN2/A,HA2/A,HHQ4/A,HXQ4/A,LHE4/A,LHZ,LJG1,LJS,LJS/A,LSS4,LSS5 LSS5/A,LSX,LT,LXQ4/A,LX2/A,PA2/A,PMT2/A,QAB2,QAB2/A,QAE2/A,QAG QAG/A,QAG2/A,QAR2/A,QA2/A,QC12,QC12/A,QE/A,QHB2,QHP1,QHQ4/A,QHZ QMH,QMX2,QTC2,QTC2/A,QW24,QXB7,QXB7/A,QXC9/A,QXE4/A,QXQ4/A,QXU QXU/A,RA2/A,RHQ4/A,RSS1,RTB2/A,RXQ4/A,SE/A,SHW,SJC1,SJC5,SMX2/A STQ/A,SXE4/A,SXQ4/A,SXU,SXU/A,VA2/A,VDG2,VDG2/A,VH12/A,VMT2,VMX VSB1,VTA2,VTA2/A,VTE2,VWC2/A,VXB/A,VXB7,VXB7/A,VXP/A,VXQ4/A,VXQ7 VXQ7/A,VXU1,VXU1/A,WKD6,WKD6/A,WKT2/A,WKT4,WKT4/A
			-	-	1	1000006	VXP,VXQP

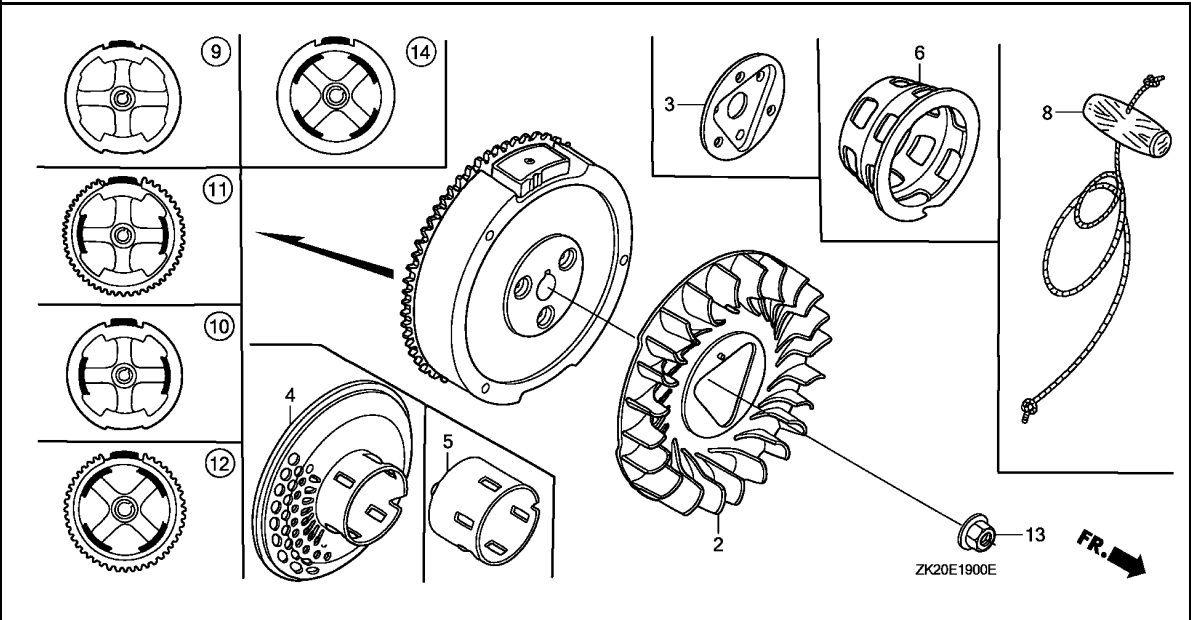

Ref. No.	Part No.	Description	Reqd. QTY			Serial No.	Parts catalogue code
			(1)	(2)	(3)		
13)	90201-ZE3-790	NUT, SPECIAL, 16MM	1	1	-	4835166	EDS1/A,EDT1/A,ED5/A,ES1/A,ES3/A,HX/A,LH/A,LJ/A,LJG/A,LKS/A,LP/A,LSX/A,LT/A,LX/A,LXF,L1/A,PX/A,QD/A,QH/A,QHP1/A,QMH/A,QP/A,QT/A,QX/A,QXC/A,QXE/A,Q1/A,RD/A,RJ/A,RSS1/A,RX/A,R1/A,SD/A,SDB3/A,SHW/A,SJ/A,SJC1/A,SJC5/A,SJG/A,SMS/A,SNR/A,STP/A,SX/A,S1/A,VH/A,VS1/A,VS3,VX/A,VXE/A,VXEB/A,VXU/A,WJ/A,W1/A
14	31100-ZE2-W01	FLYWHEEL COMP. (18A)	1	-	-	-	EDT3,ES2,VS4,WMK



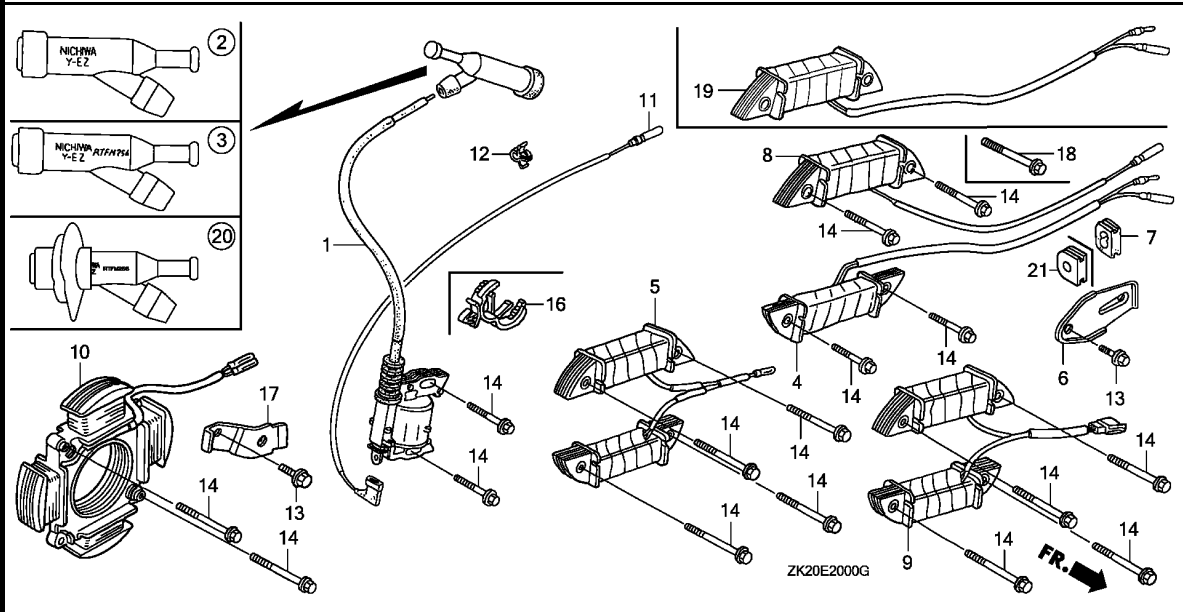

Ref. No.	L.O.N.	(Relative ref. Number) Description	F.R.T.
1	6141A5	COIL, IGNITION(ONE) (3,20)	0.3
2	6141B8	TERMINAL, HIGH TENSION (5,19)	0.1
4	6141A6	COIL, LAMP	0.4
8	6131C3	COIL, CHARGE (9,10)	0.4
11	6111B3	CORD, STOP SWITCH	0.3

Ref. No.	Part No.	Description	Reqd. QTY GX240K1 (1) (2) (3)	Serial No.	Parts catalogue code
1	30500-ZF6-W02	COIL ASSY., IGNITION	1 (1)	-----	EDN,EDN2,EDN2/A,EDS,EDS1,EDS2,EDS2/A,EDS3,EDS5,EDS6,EDS6/A,EDT1,EDT2,EDT6,EDT6/A,ED2,ED2/A,ED3,ED4,ED4/A,ED5,EN,EN2,EN2/A,ES,ES1,ES3,ET,ETS,ETX,HA,HAQ,HA2,HA2/A,HH,HHQ4,HHQ4/A,HTX,HX,HXQ4,HXQ4/A,LD,LDB1,LDB3,LH,LHE,LHE4,LHE4/A,LHZ,LJ,LJG,LJG1,LJS,LK,LKS,LM9,LNJ,LNZ,LP,LSS4,LSS5,LSS5/A,LSX,LT,LW,LX,LXQ4,LXQ4/A,LXZ,LX2,LX2/A,L1,PA,PAE,PA2,PA2/A,PMT2,PMT2/A,PX,P1,QA,QAB2,QAB2/A,QAE,QAE2,QAE2/A,QAG,QAG/A,QAG2,QAG2/A,QAQ,QAQ4,QAR2,QAR2/A,QA2,QA2/A,QC12,QC12/A,QD,QDA,QE,QE/A,QH,QHB2,QHC,QHE,QHP1,QHQ4,QHQ4/A,QHZ,QKA2,QMH,QMX2,QP,QT,QTC2,QTC2/A,QW24,QX,QXB,QXB7,QXB7/A,QXC,QXC9,QXC9/A,QXE,QXEB,QXE4,QXE4/A,QXQ4,QXQ4/A,QXU,QXU/A,Q1,RA,RA2,RA2/A,RD,RH,RHE,RHE4,RHQ4,RHQ4/A,RJ,RSC2,RSS1,RTB2,RTB2/A,RX,RXQ4,RXQ4/A,R1,SD,SDB1,SDB3,SE,SE/A,SH,SHE,SHEZ,SHW,SJ,SJC,SJC1,SJC5,SJG,SJP,SK,SMS,SMX2,SMX2/A,SNC1,SNE1,SNR,STP,STQ,STQ/A,SW,SWE,SX,SBX,SXE,SXEB,SXE4,SXE4/A,SXQ4,SXQ4/A,SXU,SXU/A,S1,VA,VAH1,VA2,VA2/A,VDG2,VDG2/A,VH,VH12,VH12/A,VMT2,VMX,VNG,VS1,VTA,VTA2,VTA2/A,VTE2,VWC2,VWC2/A,VX,VXB,VXB/A,VXB7,VXB7/A,VXE,VXEB,VXQ4,VXQ4/A,VXQ7,VXQ7/A,VXU,VXU1,VXU1/A,V1,WH,WJ,WKA,WKD6,WKD6/A,WKT2,WKT2/A,WKT4,WKT4/A,W1
			1 (1)	4847591	EDS1/A,EDT1/A,ED5/A,ES1/A,ES3/A,HX/A,LH/A,LJ/A,LJG/A,LJS/A,LKS/A,LP/A,LSX/A,LT/A,LX/A,LXF,L1/A,PX/A,QD/A,QH/A,QHP1/A,QMH/A,QP/A,QT/A,QX/A,QXC/A,QXE/A,Q1/A,RD/A,RJ/A,RSS1/A,RX/A,R1/A,SD/A,SDB3/A,SHW/A,SJ/A,SJC1/A,SJC5/A,SJG/A,SMS/A,SNR/A,STP/A,SX/A,S1/A,VH/A,VS1/A,VS3,VX/A,VXE/A,VXEB/A,VXU/A,WJ/A,W1/A
			-	-	1



Ref. No.	Part No.	Description	Reqd. QTY			Serial No.	Parts catalogue code
			(1)	(2)	(3)		
(1)	30500-ZF6-W03	COIL ASSY., IGNITION	1	(1)	-	4847592	EDS1/A,EDT1/A,ED5/A,ES1/A,ES3/A,HX/A,LH/A,LJ/A,LJG/A,LJS/A,LKS/A,LP/A,LSX/A,LT/A,LX/A,LXF,L1/A,PX/A,QD/A,QH/A,QHP1/A,QMH/A,QP/A,QT/A,QX/A,QXC/A,QXE/A,Q1/A,RD/A,RJ/A,RSS1/A,RX/A,R1/A,SD/A,SDB3/A,SHW/A,SJ/A,SJC1/A,SJC5/A,SJG/A,SMS/A,SNR/A,STP/A,SX/A,S1/A,VH/A, VSB1/A,VS3,VX/A,VXE/A,VXEB/A,VXU/A,WJ/A,W1/A
			1	-	-		EDT3,ES2,VS4,WMK
2	30600-ZE1-013	TERMINAL ASSY., HIGH TENSION (NICHIWA Y-EZ)	1	-	-		EN,ES,ES1/A,ES2,ET,ETS,ETX,LD,LDB1,LDB3,LJ,LJ/A,LJG,LJG/A,LJG1,LJS,LJS/A,LK,LM9,LNJ,LNZ,LSS5,LSS5/A,LT,LT/A,QD,ED/A,QDA,QT,QT/A,RD,RD/A,RJ,RJ/A,RSS1,RSS1/A,SD,SD/A,SDB1,SDB3,SDB3/A,SHW,SHW/A,SJ,SJ/A,SJC,SJC1,SJC1/A,SJC5,SJC5/A,SJG,SJG/A,SJP,SK,SMS,SMS/A,WJ,WJ/A,WKA,WMK
			1	-	-	3543504	ES1,ES3
			1	-	-	3860624	LSX,SNR,VSB1
			-	(1)	-		
3	30700-ZE1-013	CAP ASSY., NOISE SUPPRESSOR (NICHIWA Y-EZ RTFM256)	1	-	-		EDN,EDN2,EDN2/A,EDS,EDS1,EDS1/A,EDS2,EDS2/A,EDS3,EDS6,EDS6/A,EDT1,EDT1/A,EDT2,EDT3,EDT6,EDT6/A,ED2,ED2/A,ED3,ED4,ED4/A,ED5,ED5/A,EN2,EN2/A,ES3/A,HA,HAQ,HA2,HA2/A,HH,HHQ4,HHQ4/A,HTX,HX,HX/A,HXQ4,HXQ4/A,LH,LH/A,LHE,LHE4,LHE4/A,LHZ,LKS,LKS/A,LP,LP/A,LSS4,LSX/A,LW,LX,LX/A,LXF,LXQ4,LXQ4/A,LX2,LX2/A,PA,PAE,PA2,PA2/A,PMT2,PMT2/A,PX,PX/A,QA,QAB2,QAB2/A,QAE,QAE2,QAE2/A,QAG,QAG/A,QAG2,QAG2/A,QAQ,QAQ4,QAR2,QAR2/A,QA2,QA2/A,QC12,QC12/A,QE,QE/A,QH,QH/A,QHB2,QHC,QHE,QHP1,QHP1/A,QHQ4,QHQ4/A,QHZ,QKA2,QMH,QMH/A,QMX2,QP,QP/A,QTC2,QTC2/A,QW24,QX,QX/A,QXB,QXB7,QXB7/A,QXC,QXC/A,QXC9,QXC9/A,QXE,QXE/A,QXEB,QXE4,QXE4/A,QXQ4,QXQ4/A,QXU,QXU/A,RA,RA2,RA2/A,RH,RHE,RHE4,RHQ4,RHQ4/A,RSC2,RTB2,RTB2/A,RX,RX/A,RXQ4,RXQ4/A,SE,SE/A,SH,SHE,SHEZ,SMX2,SMX2/A,SNC1,SNE1,SNR/A,STP,STP/A,STQ,STQ/A,SW,SWE,SX,SX/A,SXB,SXE,SXEB,SXE4,SXE4/A,SXQ4,SXQ4/A,SXU,SXU/A,VA,VAH1,VA2,VA2/A,VDG2,VDG2/A,VH,VH/A,VH12,VH12/A,VMT2,VMX,VNG,VSB1/A,VS3,VS4,VTA,VTA2,VTA2/A,VTE2,VWC2/VMC2/A,VX,VX/A,VXB,VXB/A,VXB7,VXB7/A,VXE,VXE/A,VXEB,VXEB/A,VXQ4,VXQ4/A,VXQ7,VXQ7/A,VXU,VXU/A,VXU1,VXU1/A,WH,WKD6,WKD6/A,WKT2,WKT2/A,WKT4,WKT4/A
			1	-	-	3860625	LSX,SNR,VSB1
			1	-	-	3543503	ES1,ES3
			-	(1)	1		
4	31510-ZE1-831	COIL ASSY., LAMP (6V/25W) ...	-	(1)	-		
	31510-ZE3-003	COIL ASSY., LAMP (12V/25W) ..	1	-	-		EDN,EDN2,EDN2/A
5	31510-ZE2-811	COIL ASSY., LAMP (12V/50W) ..	1	-	-		LT,LT/A,LW,QAG2,QAG2/A,QP,QP/A,RSC2,SNC1,SW
			-	(1)	-		
	31630-ZE2-E11	COIL ASSY., CHARGE	1	-	-		EDS5,WKA
	31630-ZF1-801	COIL ASSY., CHARGE (2.8A) ...	1	-	-		LNJ,LNZ
6	31511-ZE2-000	CLAMPER, CORD	1	-	-		EDN,EDN2,EDN2/A,EDS,EDS1,EDS1/A,EDS2,EDS2/A,EDS3,EDS5,EDS6,EDS6/A,ED2,ED2/A,ED3,EN2,EN2/A,ETS,LHE,LHE4,LHE4/A,LKS,LKS/A,LNJ,LNZ,LSS5,LSS5/A,LT,LT/A,LW,PAE,QAE,QAE2,QAE2/A,QAG2,QAG2/A,QHE,QKA2,QP,QP/A,QXE,QXE/A,QXEB,QXE4,QXE4/A,RHE,RHE4,RSC2,RSS1,RSS1/A,SHE,SHEZ,SHW,SHW/A,SNC1,SNE1,SW,SWE,SXE,SXEB,SXE4,SXE4/A,VTE2,VXE,VXE/A,VXEB,VXEB/A,WKA
			-	(1)	-		



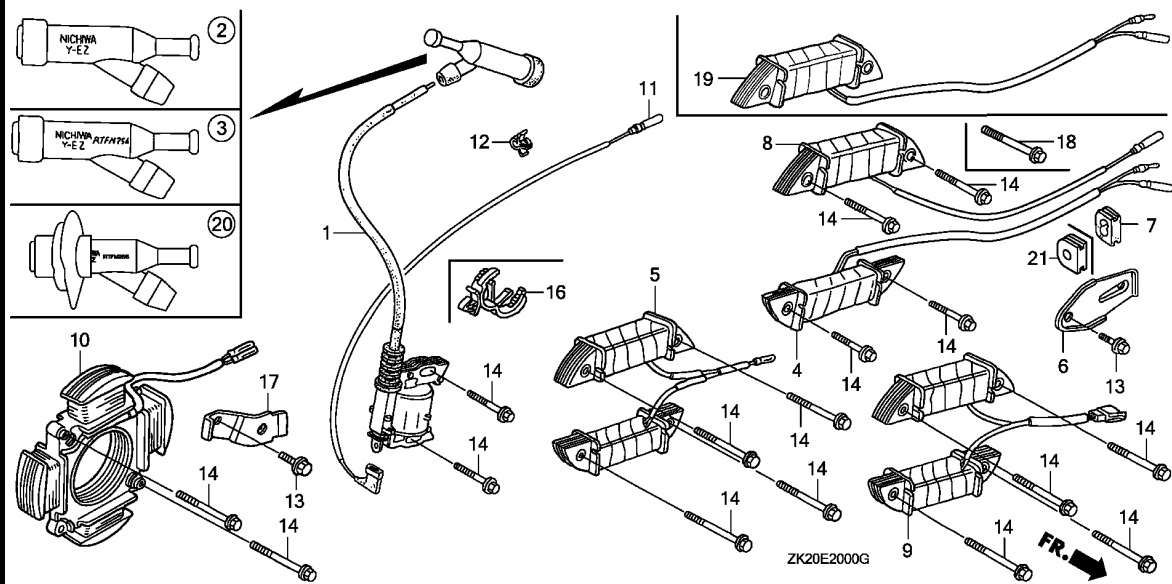

Ref. No.	Part No.	Description	Reqd. QTY			Serial No.	Parts catalogue code
			(1)	(2)	(3)		
7	31512-ZE2-000	GROMMET, CORD	1	-	-	-----	EDN,EDN2,EDN2/A,EDS,EDS1,EDS1/A,EDS2,EDS2/A,EDS3,EDS5,EDS6,EDS6/A,EDT1,EDT1/A,EDT2,EDT3,EDT6,EDT6/A,ED2,ED2/A,ED3,ED4,ED4/A,ED5,ED5/A,EN,EN2,EN2/A,ES,ES1,ES1/A,ES2,ES3,ES3/A,ET,ETS,ETX,HA,HAQ,HA2,HA2/A,HH,HHQ4,HHQ4/A,HTX,HX,HX/A,HXQ4,HXQ4/A,LD,LDB1,LDB3,LH,LH/A,LHE,LHE4,LHE4/A,LHZ,LJ,LJ/A,LJG,LJG/A,LJG1,LJS,LJS/A,LK,LKS,LKS/A,LM9,LNJ,LNZ,LP,LP/A,LSS4,LSS5,LSS5/A,LSX,LSX/A,LT,LT/A,LW,LX,LX/A,LXF,LXQ4,LXQ4/A,LXZ,LX2,LX2/A,PA,PAE,PA2,PA2/A,PMT2,PMT2/A,PX,PX/A,QA,QAB2,QAB2/A,QAE,QAE2,QAE2/A,QAG,QAG/A,QAG2,QAG2/A,QAQ,QAQ4,QAR2,QAR2/A,QA2,QA2/A,QC12,QC12/A,QD,QD/A,QDA,QE,QE/A,QH,QH/A,QHB2,QHC,QHE,QHP1,QHP1/A,QHQ4,QHQ4/A,QHZ,QKA2,QMH,QMH/A,QMX2,QP,QP/A,QT,QT/A,QTC2,QTC2/A,QW24,QX,QX/A,QXB,QXB7,QXB7/A,QXC,QXC/A,QXC9,QXC9/A,QXE,QXE/A,QXEB,QXE4,QXE4/A,QXQ4,QXQ4/A,QXU,QXU/A,RA,RA2,RA2/A,RD,RD/A,RH,RHE,RHE4,RHQ4,RHQ4/A,RJ,RJ/A,RSC2,RSS1,RSS1/A,RTB2,RTB2/A,RX,RX/A,RXQ4,RXQ4/A,SD,SD/A,SDB1,SDB3,SDB3/A,SE,SE/A,SH,SHE,SHEZ,SHW,SHW/A,SJ,SJ/A,SJC,SJC1,SJC1/A,SJC5,SJC5/A,SJG,SJG/A,SJP,SK,SMS,SMS/A,SMX2,SMX2/A,SNE1,SNR,SNR/A,STP,STP/A,STQ,STQ/A,SW,SWE,SX,SX/A,SXB,SXE,SXEB,SXE4,SXE4/A,SXQ4,SXQ4/A,SXU,SXU/A,VA,VAH1,VA2,VA2/A,VDG2,VDG2/A,VH,VH/A,VH12,VH12/A,VMT2,VMX,VNG,VSB1,VSB1/A,VS3,VS4,VTA,VTA2,VTA2/A,VTE2,VWC2,VWC2/A,VX,VX/A,VXB,VXB/A,VXB7,VXB7/A,VXE,VXE/A,VXEB,VXEB/A,VXQ4,VXQ4/A,VXQ7,VXQ7/A,VXU,VXU/A,VXU1,VXU1/A,WH,WJ,WJ/A,WKA,WKD6,WKD6/A,WKT2,WKT2/A,WKT4,WKT4/A,WMK
8	31630-ZE1-003	COIL ASSY., CHARGE (1A)	1	1	-	-----	EDS,EDS1,EDS2,EDS2/A,EDS3,EDS6,EDS6/A,ED3,ETS,LHE,LHE4,LHE4/A,L1,P1,QHE,QXE,QXEB,QXE4,QXE4/A,Q1,Q1/A,RHE,RHE4,RSS1,R1,SHE,SHEZ,SWE,SXE,SXEB,SXE4,SXE4/A,S1,VXE,VXEB,V1,W1,W1/A
	31630-ZE1-013	1	1	4847898	-----	EDS1/A,L1/A,QXE/A,RSS1/A,R1/A,S1/A,VXE/A,VXEB/A
		1	1	4847899	-----	EDS1/A,L1/A,QXE/A,RSS1/A,R1/A,S1/A,VXE/A,VXEB/A

Ref. No.	Part No.	Description	Reqd. QTY			Serial No.	Parts catalogue code
			(1)	(2)	(3)		
(8)	31630-ZE2-841	COIL ASSY., CHARGE (3A)	1	(1)	-	-----	L1,P1,QAE,QAE2,QAE2/A,Q1,R1,SHW,S1,V1,W1
	31630-ZE2-842	1	(1)	-	4847898	L1/A,Q1/A,R1/A,SHW/A,S1/A,W1/A
9	31630-ZE2-861	COIL ASSY., CHARGE (10A)	1	(1)	-	4847899	L1/A,Q1/A,R1/A,SHW/A,S1/A,W1/A
			-	(1)	-		LKS,LKS/A,LSS5,LSS5/A,PAE,QKA2,SNE1
10	31630-ZE2-W01	COIL ASSY., CHARGE (12V/18A)	1	(1)	-	-----	L1/A,QAR2,QAR2/A,Q1/A,R1/A,S1/A,W1/A
			-	(1)	-	3331782	L1,P1,Q1,R1,S1,V1,W1
11	36101-ZE1-010	CORD, STOP SWITCH (370MM) ...	1	-	-	-----	ED3,ED4,ED4/A,ED5,ED5/A,EN,ES,ES1,ES1/A,ES2,ET,ETS,ETX,HA,HAQ,HA2,HA2/A,HH,HHQ4,HHQ4/A,HTX,HX,HX/A,HXQ4,HXQ4/A,LD,LDB1,LDB3,LH,LH/A,LHE,LHE4,LHE4/A,LHZ,LJ,LJ/A,LJG,LJG/A,LJG1,LJS,LJS/A,LK,LKS,LKS/A,LM9,LNJ,LNZ,LP,LP/A,LSS4,LSS5,LSS5/A,LSX,LSX/A,LT,LT/A,LW,LX,LX/A,LXF,LXQ4,LXQ4/A,LXZ,LX2,LX2/A,PA,PAE,PA2,PA2/A,PMT2,PMT2/A,PX,PX/A,QA,QAB2,QAB2/A,QAE,QAE2,QAE2/A,QAG,QAG/A,QAG2,QAG2/A,QAQ,QAQ4,QAR2,QAR2/A,QA2,QA2/A,QC12,QC12/A,QD,QD/A,QDA,QE,QE/A,QH,QH/A,QHB2,QHC,QHE,QHP1,QHP1/A,QHQ4,QHQ4/A,QHZ,QKA2,QMH,QMH/A,QMX2,QP,QP/A,QT,QT/A,QTC2,QTC2/A,QW24,QX,QX/A,QXB,QXB7,QXB7/A,QXC,QXC/A,QXC9,QXC9/A,QXE,QXE/A,QXEB,QXE4,QXE4/A,QXQ4,QXQ4/A,QXU,QXU/A,RA,RA2,RA2/A,RD,RD/A,RH,RHE,RHE4,RHQ4,RHQ4/A,RJ,RJ/A,RSC2,RSS1,RSS1/A,RTB2,RTB2/A,RX,RX/A,RXQ4,RXQ4/A,SD,SD/A,SDB1,SDB3,SDB3/A,SE,SE/A,SH,SHE,SHEZ,SHW,SHW/A,SJ,SJ/A,SJC,SJC1,SJC1/A,SJC5,SJC5/A,SJG,SJG/A,SJP,SK,SMS,SMS/A,SMX2,SMX2/A,SNC1,SNE1,SNR,SNR/A,STP,STP/A,STQ,STQ/A,SW,SWE,SX,SX/A,SXB,SXE,SXEB,SXE4,SXE4/A,SXQ4,SXQ4/A,SXU,SXU/A,VA,VAH1,VA2,VA2/A,VDG2,VDG2/A,VH,VH/A,VH12,VH12/A,VMT2,VMX,VNG,VTA,VTA2,VTA2/A,VWC2,VWC2/A,VX,VX/A,VXB,VXB/A,VXB7,VXB7/A,VXE,VXE/A,VXEB,VXEB/A,VXQ4,VXQ4/A,VXQ7,VXQ7/A,VXU,VXU/A,VXU1,VXU1/A,WH,WJ,WJ/A,WKA,WKD6,WKD6/A,WKT2,WKT2/A,WKT4,WKT4/A,WMK
	36101-ZE2-701	CORD, STOP SWITCH (430MM) ...	-	(1)	1	-----	EDN,EDN2,EDN2/A,EDS,EDS1,EDS1/A,EDS2,EDS2/A,EDS3,EDS5,EDS6,EDS6/A,EDT1,EDT1/A,EDT2,EDT3,EDT6,EDT6/A,ED2,ED2/A,EN2,EN2/A,ES3,ES3/A, VSB1,VSB1/A,VS3,VS4,VTE2
12	36103-ZE1-000	HOLDER, STOP SWITCH CORD	1	-	-	-----	EDN,EDN2,EDN2/A,ED3,ED4,ED4/A,EN,ES,ES3,ES3/A,ET,ETS,HH,HHQ4,HHQ4/A,HTX,LD,LDB1,LDB3,LH,LH/A,LHE,LHE4,LHE4/A,LHZ,LJ,LJ/A,LJG,LJG/A,LJG1,LJS,LJS/A,LK,LKS,LKS/A,LM9,LP,LP/A,LSS4,LSS5,LSS5/A,LT,LT/A,LW,PAE,QAE,QAE2,QAE2/A,QAR2,QAR2/A,QC12,QC12/A,QD,QD/A,QDA,QA,QE,QA/A,QH,QH/A,QHB2,QHC,QHE,QHP1,QHP1/A,QHQ4,QHQ4/A,QHZ,QMH,QMH/A,QP,QP/A,QT,QT/A,QXE,QXE/A,QXEB,QXE4,QXE4/A,RD,RD/A,RH,RHE,RHE4,RHQ4,RHQ4/A,RJ,RJ/A,RSS1,RSS1/A,SD,SD/A,SDB1,SDB3,SDB3/A,SE,SE/A,SH,SHE,SHEZ,SJ,SJ/A,SJC,SJG,SJG/A,SK,SNE1,STP,STP/A,STQ,STQ/A,SW,SWE,SXE,SXEB,SXE4,SXE4/A,VH,VH/A,VSB1,VSB1/A,VS3,VS4,VTE2,VXE,VXE/A,VXEB,VXEB/A,WH,WJ,WJ/A,WMK
	30701-883-000	CLIP, HIGH TENSION CORD (8MM)	-	(1)	-	-----	ES1,HX,LX,LXZ,PX,QA,QAE,QX,QXB,QXC,QXU,RX,SX,SXB,SXU,VNG,VX,VXB
13	90013-883-000	BOLT, FLANGE, 6X12(CT200) ...	1	-	-	-----	EDN,EDN2,EDN2/A,EDS,EDS1,EDS1/A,EDS2,EDS2/A,EDS3,EDS5,EDS6,EDS6/A,ED2,ED2/A,ED3,EN2,EN2/A,ETS,LHE,LHE4,LHE4/A,LKS,LKS/A,LNJ,LNZ,LSS5,LSS5/A,LT,LT/A,LW,PAE,QAE,QAE2,QAE2/A,QAG2,QAG2/A,QAR2,QAR2/A,QHE,QKA2,QP,QP/A,QXE,QXE/A,QXEB,QXE4,QXE4/A,RHE,RHE4,RSC2,RSS1,RSS1/A,SHE,SHEZ,SHW,SHW/A,SNC1,SNE1,SW,SWE,SXE,SXEB,SXE4,SXE4/A,VTE2,VXE,VXE/A,VXEB,VXEB/A,WKA
			-	(1)	-		



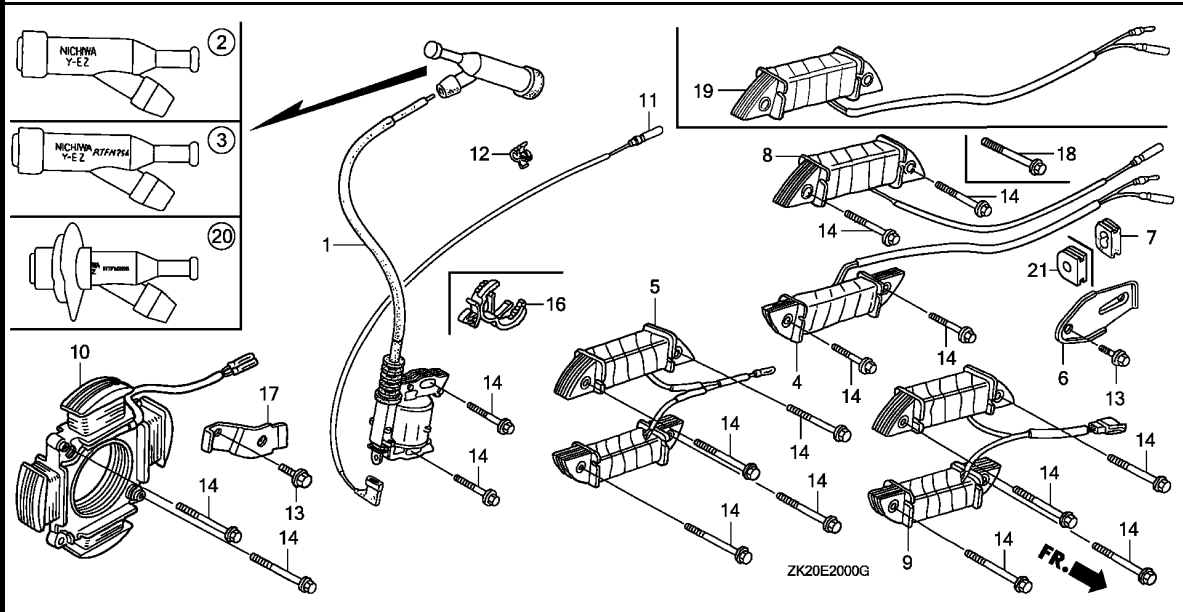

Ref. No.	Part No.	Description	Reqd. QTY			Serial No.	Parts catalogue code
			(1)	(2)	(3)		
14	90015-883-000	BOLT, FLANGE, 6X28	N	-	-	-----	EDN,EDN2,EDN2/A,EDS,EDS1,EDS1/A,EDS2,EDS2/A,EDS3,EDS5,EDS6,EDS6/A,EDT1,EDT1/A,EDT2,EDT6,EDT6/A,ED2,ED2/A,ED3,ED4,ED4/A,ED5,ED5/A,EN,EN2,EN2/A,ES,ES1,ES1/A,ES3,ES3/A,ET,ETS,ETX,HA,HAQ,HA2,HA2/A,HH,HHQ4,HHQ4/A,HTX,HX,HX/A,HXQ4,HXQ4/A,LD,LDB1,LDB3,LH,LH/A,LHE,LHE4,LHE4/A,LHZ,LJ,LJ/A,LJG,LJG/A,LJG1,LJS,LJS/A,LK,LKS,LKS/A,LM9,LMJ,LNZ,LP,LP/A,LSS4,LSS5,LSS5/A,LSX,LSX/A,LT,LT/A,LW,LX,LX/A,LXF,LXQ4,LXQ4/A,LXZ,LX2,LX2/A,PA,PAE,PA2,PA2/A,PMT2,PMT2/A,PX,PX/A,QA,QAB2,QAB2/A,QAE,QAE2,QAE2/A,QAG,QAG/A,QAG2,QAG2/A,QAQ,QAQ4,QAR2,QAR2/A,QA2,QA2/A,QC12,QC12/A,QD,QD/A,QDA,QE,QE/A,QH,QH/A,QHB2,QHC,QHE,QHP1,QHP1/A,QHQ4,QHQ4/A,QHZ,QKA2,QMH,QMH/A,QMX2,QP,QP/A,QT,QT/A,QTC2,QTC2/A,QW24,QX,QX/A,QXB,QXB7,QXB7/A,QXC,QXC/A,QXC9,QXC9/A,QXE,QXE/A,QXEB,QXE4,QXE4/A,QXQ4,QXQ4/A,QXU,QXU/A,RA,RA2,RA2/A,RD,RD/A,RH,RHE,RHE4,RHQ4,RHQ4/A,RJ,RJ/A,RSC2,RSS1,RSS1/A,RTB2,RTB2/A,RX,RX/A,RXQ4,RXQ4/A,SD,SD/A,SDB1,SDB3,SDB3/A,SE,SE/A,SH,SHE,SHEZ,SHW,SHW/A,SJ,SJ/A,SJC,SJC1,SJC1/A,SJC5,SJC5/A,SJG,SJG/A,SJP,SK,SMS,SMS/A,SMX2,SMX2/A,SNC1,SNE1,SNR,SNR/A,STP,STP/A,STQ,STQ/A,SW,SWE,SX,SX/A,SXB,SXE,SXEB,SXE4,SXE4/A,SXQ4,SXQ4/A,SXU,SXU/A,VA,VAH1,VA2,VA2/A,VDG2,VDG2/A,VH,VH/A,VH12,VH12/A,VMT2,VMX,VNG,VSB1,VSB1/A,VS3,VTA,VTA2,VTA2/A,VTE2,VWC2,VWC2/A,VX,VX/A,VXB,VXB/A,VXB7,VXB7/A,VXE,VXE/A,VXEB,VXEB/A,VXQ4,VXQ4/A,VXQ7,VXQ7/A,VXU,VXU/A,VXU1,VXU1/A,WH,WJ,WJ/A,WKA,WKD6,WKD6/A,WKT2,WKT2/A,WKT4,WKT4/A,WMK
			2	-	-	-----	EDT3,ES2,VS4
			-	(N)	N	-----	

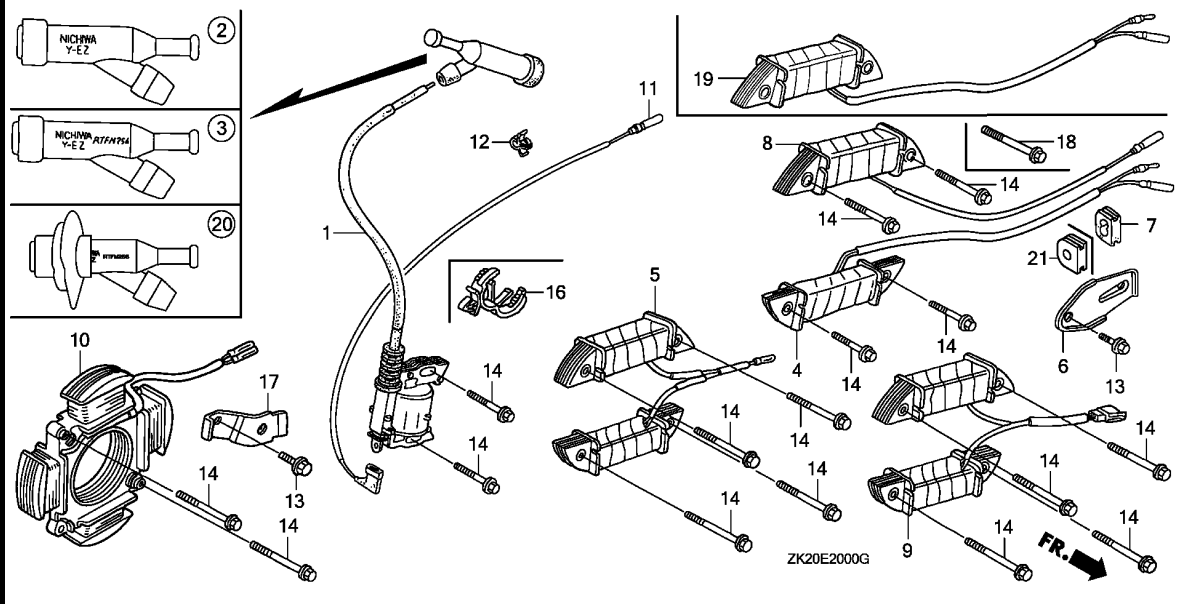

Ref. No.	Part No.	Description	Reqd. QTY			Serial No.	Parts catalogue code	
			(1)	(2)	(3)			
16	90684-ZA0-601	CLIP, HARNESS	1	-	-	-----	EDT1,EDT1/A,EDT2,EDT3,EDT6,EDT6/A,ES2,HXQ4,HXQ4/A,LSX,LSX/A,LXF,LXQ4,LXQ4/A,QAB2,QAB2/A,QAQ4,QKA2,QMX2,QTC2,QTC2/A,QXQ4,QXQ4/A,RTB2,RTB2/A,RXQ4,RXQ4/A,SJC1,SJC1/A,SJC5,SJC5/A,SMS,SMS/A,SNC1,SXQ4,SXQ4/A,VDG2,VDG2/A,VMT2,VMX,VWC2,VWC2/A,VXQ4,VXQ4/A,WKD6,WKD6/A,WKT4,WKT4/A	
17	31511-ZE2-W00	CLAMPER, CORD	1	(1)	1	-----	L1/A,QAR2,QAR2/A,Q1/A,R1/A,S1/A,W1/A	
18	90017-883-000	BOLT, FLANGE, 6X32	-	(1)	-	3331782	-----	L1,P1,Q1,R1,S1,V1,W1
19	31510-ZE1-811	COIL ASSY., LAMP (12V/25W)	1	-	-	-----	SHW,SHW/A	
20	30700-ZB7-013	CAP ASSY., NOISE SUPPRESSOR (NICHIIWA Y-EZ RTFM256)	1	-	-	-----	EDN,EDN2,EDN2/A,ED2,ED2/A,EN2,EN2/A,VTE2	
21	31512-ZG3-000	GROMMET, CORD	-	(1)	-	3331781	L1,P1,Q1,R1,S1,V1,W1	



E-21

STARTER MOTOR

2-B15

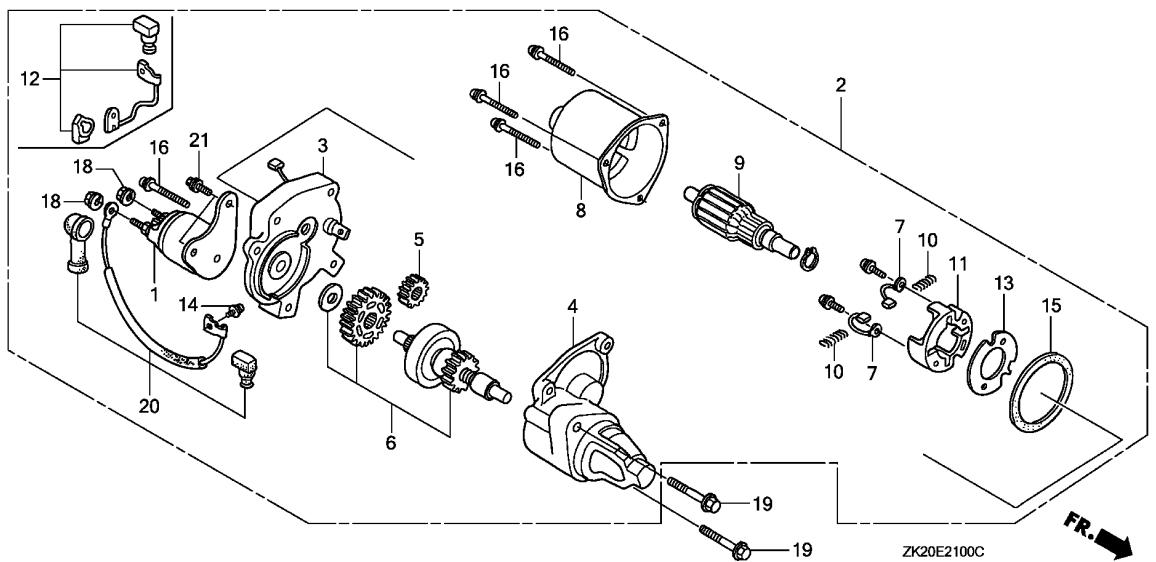

Ref. No.	L.O.N.	(Relative ref. Number) Description	F.R.T.
1	6121E5	CONTACTOR, STARTER	0.2
2	6121D5	MOTOR, STARTER	0.2
3	6121C3	BRACKET, STARTER :CENTER	0.4
4	6121D2	BRACKET, STARTER :FRONT	0.4
6	6121B0	CLUTCH, OVERRUNNING	0.4
7	6121A9	BRUSH, STARTER	0.4
8	6121D1	YOKE, STARTER	0.4
9	6121A0	ARMATURE, STARTER	0.4

Ref. No.	Part No.	Description	Reqd. QTY			Serial No.	Parts catalogue code
			(1)	(2)	(3)		
1	31204-ZA0-003	CONTACTOR ASSY.	1	-	-	-----	EDS,EDS1,EDS1/A,EDS2,EDS2/A,EDS3,EDS5,EDS6,EDS6/A,ED3,ETS,LHE LHE4,LHE4/A,LKS,LKS/A,LNJ,LNZ,LSS5,LSS5/A,PAE,QAE,QAE2,QAE2/A QAR2,QAR2/A,QHE,QXE,QXE/A,QXEB,QXE4,QXE4/A,RHE,RHE4,RSS1,RSS1/A SHE,SHEZ,SHW,SHW/A,SNE1,SWE,SXE,SXEB,SXE4,SXE4/A,VXE,VXE/A,VXEB VXEB/A,WKA
2	31210-ZB7-003 31210-ZE2-003	MOTOR UNIT, STARTER	1	(1)	-	-----	EDS5
		1	-	-	-----	EDS,EDS1,EDS1/A,EDS2,EDS2/A,EDS3,EDS6,EDS6/A,ED3,ETS,LHE,LHE4 LHE4/A,LKS,LKS/A,LNJ,LNZ,LSS5,LSS5/A,PAE,QAE,QAE2,QAE2/A,QAR2 QAR2/A,QHE,QXE,QXE/A,QXEB,QXE4,QXE4/A,RHE,RHE4,RSS1,RSS1/A,SHE SHEZ,SHW,SHW/A,SNE1,SWE,SXE,SXEB,SXE4,SXE4/A,VXE,VXE/A,VXEB VXEB/A,WKA
3	31211-ZE2-003	BRACKET, CENTER	1	(1)	-	-----	EDS,EDS1,EDS1/A,EDS2,EDS2/A,EDS3,EDS5,EDS6,EDS6/A,ED3,ETS,LHE LHE4,LHE4/A,LKS,LKS/A,LNJ,LNZ,LSS5,LSS5/A,PAE,QAE,QAE2,QAE2/A QAR2,QAR2/A,QHE,QXE,QXE/A,QXEB,QXE4,QXE4/A,RHE,RHE4,RSS1,RSS1/A SHE,SHEZ,SHW,SHW/A,SNE1,SWE,SXE,SXEB,SXE4,SXE4/A,VXE,VXE/A,VXEB VXEB/A,WKA
4	31212-ZE2-003	BRACKET, FR.	1	(1)	-	-----	EDS,EDS1,EDS1/A,EDS2,EDS2/A,EDS3,EDS5,EDS6,EDS6/A,ED3,ETS,LHE LHE4,LHE4/A,LKS,LKS/A,LNJ,LNZ,LSS5,LSS5/A,PAE,QAE,QAE2,QAE2/A QAR2,QAR2/A,QHE,QXE,QXE/A,QXEB,QXE4,QXE4/A,RHE,RHE4,RSS1,RSS1/A SHE,SHEZ,SHW,SHW/A,SNE1,SWE,SXE,SXEB,SXE4,SXE4/A,VXE,VXE/A,VXEB VXEB/A,WKA
			-	(1)	-		

2

Ref. No.	Part No.	Description	Reqd. QTY			Serial No.	Parts catalogue code
			(1)	(2)	(3)		
5	31213-ZE2-003	GEAR, DRIVE PINION	1	-	-	-----	EDS,EDS1,EDS1/A,EDS2,EDS2/A,EDS3,EDS5,EDS6,EDS6/A,ED3,ETS,LHE LHE4,LHE4/A,LKS,LKS/A,LNJ,LNZ,LSS5,LSS5/A,PAE,QAE,QAE2,QAE2/A QAR2,QAR2/A,QHE,QXE,QXE/A,QXEB,QXE4,QXE4/A,RHE,RHE4,RSS1,RSS1/A SHE,SHEZ,SHW,SHW/A,SNE1,SWE,SXE,SXEB,SXE4,SXE4/A,VXE,VXE/A,VXEB VXEB/A,WKA
			-	(1)	-		
6	31214-ZE2-003	CLUTCH COMP., OVERRUNNING ...	1	-	-	-----	EDS,EDS1,EDS1/A,EDS2,EDS2/A,EDS3,EDS5,EDS6,EDS6/A,ED3,ETS,LHE LHE4,LHE4/A,LKS,LKS/A,LNJ,LNZ,LSS5,LSS5/A,PAE,QAE,QAE2,QAE2/A QAR2,QAR2/A,QHE,QXE,QXE/A,QXEB,QXE4,QXE4/A,RHE,RHE4,RSS1,RSS1/A SHE,SHEZ,SHW,SHW/A,SNE1,SWE,SXE,SXEB,SXE4,SXE4/A,VXE,VXE/A,VXEB VXEB/A,WKA
			-	(1)	-		
7	31215-ZE2-003	BRUSH	2	-	-	-----	EDS,EDS1,EDS1/A,EDS2,EDS2/A,EDS3,EDS5,EDS6,EDS6/A,ED3,ETS,LHE LHE4,LHE4/A,LKS,LKS/A,LNJ,LNZ,LSS5,LSS5/A,PAE,QAE,QAE2,QAE2/A QAR2,QAR2/A,QHE,QXE,QXE/A,QXEB,QXE4,QXE4/A,RHE,RHE4,RSS1,RSS1/A SHE,SHEZ,SHW,SHW/A,SNE1,SWE,SXE,SXEB,SXE4,SXE4/A,VXE,VXE/A,VXEB VXEB/A,WKA
			-	(2)	-		
8	31216-ZE2-003	YOKE COMP.	1	-	-	-----	EDS,EDS1,EDS1/A,EDS2,EDS2/A,EDS3,EDS5,EDS6,EDS6/A,ED3,ETS,LHE LHE4,LHE4/A,LKS,LKS/A,LNJ,LNZ,LSS5,LSS5/A,PAE,QAE,QAE2,QAE2/A QAR2,QAR2/A,QHE,QXE,QXE/A,QXEB,QXE4,QXE4/A,RHE,RHE4,RSS1,RSS1/A SHE,SHEZ,SHW,SHW/A,SNE1,SWE,SXE,SXEB,SXE4,SXE4/A,VXE,VXE/A,VXEB VXEB/A,WKA
			-	(1)	-		
9	31217-ZE2-003	ARMATURE COMP.	1	-	-	-----	EDS,EDS1,EDS1/A,EDS2,EDS2/A,EDS3,EDS5,EDS6,EDS6/A,ED3,ETS,LHE LHE4,LHE4/A,LKS,LKS/A,LNJ,LNZ,LSS5,LSS5/A,PAE,QAE,QAE2,QAE2/A QAR2,QAR2/A,QHE,QXE,QXE/A,QXEB,QXE4,QXE4/A,RHE,RHE4,RSS1,RSS1/A SHE,SHEZ,SHW,SHW/A,SNE1,SWE,SXE,SXEB,SXE4,SXE4/A,VXE,VXE/A,VXEB VXEB/A,WKA
			-	(1)	-		
10	31219-ZE2-003	SPRING, BRUSH RETURN	4	-	-	-----	EDS,EDS1,EDS1/A,EDS2,EDS2/A,EDS3,EDS5,EDS6,EDS6/A,ED3,ETS,LHE LHE4,LHE4/A,LKS,LKS/A,LNJ,LNZ,LSS5,LSS5/A,PAE,QAE,QAE2,QAE2/A QAR2,QAR2/A,QHE,QXE,QXE/A,QXEB,QXE4,QXE4/A,RHE,RHE4,RSS1,RSS1/A SHE,SHEZ,SHW,SHW/A,SNE1,SWE,SXE,SXEB,SXE4,SXE4/A,VXE,VXE/A,VXEB VXEB/A,WKA
			-	(4)	-		
11	31231-ZE2-003	HOLDER, BRUSH	1	-	-	-----	EDS,EDS1,EDS1/A,EDS2,EDS2/A,EDS3,EDS5,EDS6,EDS6/A,ED3,ETS,LHE LHE4,LHE4/A,LKS,LKS/A,LNJ,LNZ,LSS5,LSS5/A,PAE,QAE,QAE2,QAE2/A QAR2,QAR2/A,QHE,QXE,QXE/A,QXEB,QXE4,QXE4/A,RHE,RHE4,RSS1,RSS1/A SHE,SHEZ,SHW,SHW/A,SNE1,SWE,SXE,SXEB,SXE4,SXE4/A,VXE,VXE/A,VXEB VXEB/A,WKA
			-	(1)	-		
12	31232-ZB7-003	WIRE, WATER COVER	1	-	-	-----	EDS5
13	31233-ZE2-003	INSULATOR	1	-	-	-----	EDS,EDS1,EDS1/A,EDS2,EDS2/A,EDS3,EDS5,EDS6,EDS6/A,ED3,ETS,LHE LHE4,LHE4/A,LKS,LKS/A,LNJ,LNZ,LSS5,LSS5/A,PAE,QAE,QAE2,QAE2/A QAR2,QAR2/A,QHE,QXE,QXE/A,QXEB,QXE4,QXE4/A,RHE,RHE4,RSS1,RSS1/A SHE,SHEZ,SHW,SHW/A,SNE1,SWE,SXE,SXEB,SXE4,SXE4/A,VXE,VXE/A,VXEB VXEB/A,WKA
			-	(1)	-		
14	90110-ZE2-003	SCREW-WASHER, 4X6	1	-	-	-----	EDS,EDS1,EDS1/A,EDS2,EDS2/A,EDS3,EDS5,EDS6,EDS6/A,ED3,ETS,LHE LHE4,LHE4/A,LKS,LKS/A,LNJ,LNZ,LSS5,LSS5/A,PAE,QAE,QAE2,QAE2/A QAR2,QAR2/A,QHE,QXE,QXE/A,QXEB,QXE4,QXE4/A,RHE,RHE4,RSS1,RSS1/A SHE,SHEZ,SHW,SHW/A,SNE1,SWE,SXE,SXEB,SXE4,SXE4/A,VXE,VXE/A,VXEB VXEB/A,WKA
			-	(1)	-		



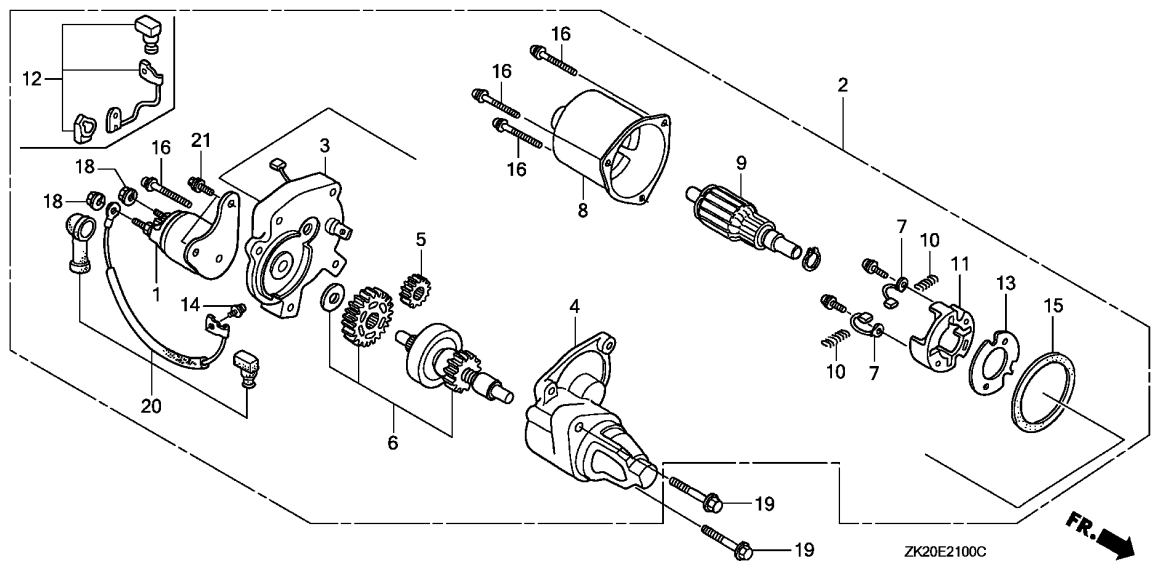

2

Ref. No.	Part No.	Description	Reqd. QTY			Serial No.	Parts catalogue code
			(1)	(2)	(3)		
15	91601-ZE2-003	PACKING	1	-	-	-----	EDS,EDS1,EDS1/A,EDS2,EDS2/A,EDS3,EDS5,EDS6,EDS6/A,ED3,ETS,LHE LHE4,LHE4/A,LKS,LKS/A,LNJ,LNZ,LSS5,LSS5/A,PAE,QAE,QAE2,QAE2/A QAR2,QAR2/A,QHE,QXE,QXE/A,QXEB,QXE4,QXE4/A,RHE,RHE4,RSS1,RSS1/A SHE,SHEZ,SHW,SHW/A,SNE1,SWE,SXE,SXEB,SXE4,SXE4/A,VXE,VXE/A,VXEB VXEB/A,WKA
			-	(1)	-		
16	93892-05032-18	SCREW-WASHER, 5X32	4	-	-	-----	EDS,EDS1,EDS1/A,EDS2,EDS2/A,EDS3,EDS5,EDS6,EDS6/A,ED3,ETS,LHE LHE4,LHE4/A,LKS,LKS/A,LNJ,LNZ,LSS5,LSS5/A,PAE,QAE,QAE2,QAE2/A QAR2,QAR2/A,QHE,QXE,QXE/A,QXEB,QXE4,QXE4/A,RHE,RHE4,RSS1,RSS1/A SHE,SHEZ,SHW,SHW/A,SNE1,SWE,SXE,SXEB,SXE4,SXE4/A,VXE,VXE/A,VXEB VXEB/A,WKA
			-	(4)	-		
18	94070-06080	NUT-WASHER, 6MM	2	-	-	-----	EDS,EDS1,EDS1/A,EDS2,EDS2/A,EDS3,EDS5,EDS6,EDS6/A,ED3,ETS,LHE LHE4,LHE4/A,LKS,LKS/A,LNJ,LNZ,LSS5,LSS5/A,PAE,QAE,QAE2,QAE2/A QAR2,QAR2/A,QHE,QXE,QXE/A,QXEB,QXE4,QXE4/A,RHE,RHE4,RSS1,RSS1/A SHE,SHEZ,SHW,SHW/A,SNE1,SWE,SXE,SXEB,SXE4,SXE4/A,VXE,VXE/A,VXEB VXEB/A,WKA
			-	(2)	-		
19	95701-08040-00	BOLT, FLANGE, 8X40	2	-	-	-----	EDS,EDS1,EDS1/A,EDS2,EDS2/A,EDS3,EDS5,EDS6,EDS6/A,ED3,ETS,LHE LHE4,LHE4/A,LKS,LKS/A,LNJ,LNZ,LSS5,LSS5/A,PAE,QAE,QAE2,QAE2/A QAR2,QAR2/A,QHE,QXE,QXE/A,QXEB,QXE4,QXE4/A,RHE,RHE4,RSS1,RSS1/A SHE,SHEZ,SHW,SHW/A,SNE1,SWE,SXE,SXEB,SXE4,SXE4/A,VXE,VXE/A,VXEB VXEB/A,WKA
			-	(2)	-		

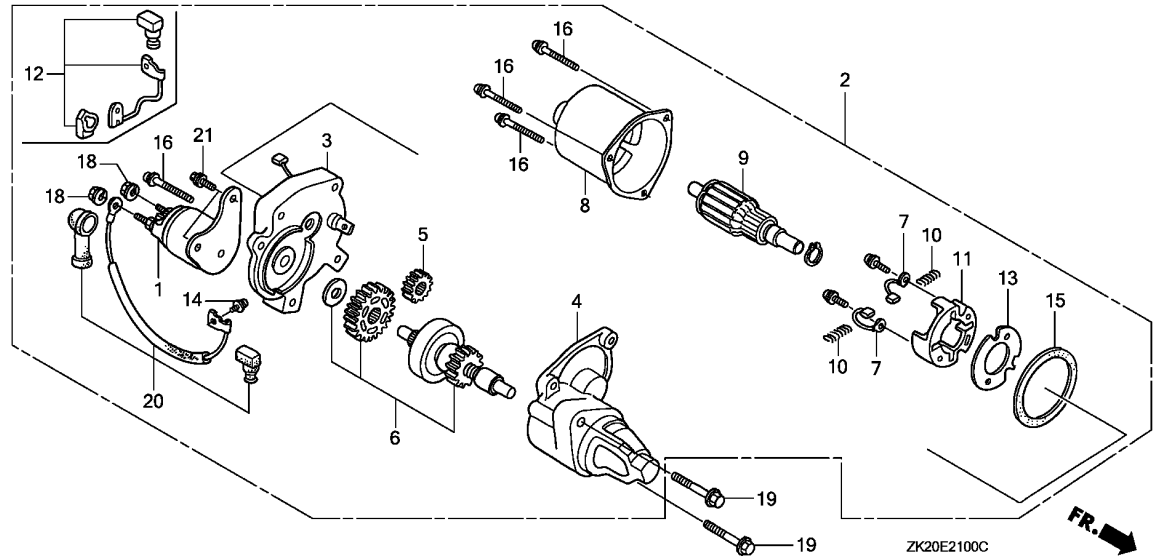

Ref. No.	Part No.	Description	Reqd. QTY			Serial No.	Parts catalogue code
			(1)	(2)	(3)		
20	31232-ZE2-013	WIRE, WATER COVER	1	(1)	-	-----	EDS,EDS1,EDS2,EDS2/A,EDS3,EDS6,EDS6/A,ED3,ETS,LHE,LHE4,LHE4/A,LKS LNJ,LNZ,LSS5,LSS5/A,L1,PAE,P1,QAE,QAE2,QAE2/A,QAR2,QAR2/A,QHE,QXE QXEB,QXE4,QXE4/A,Q1,RHE,RHE4,RSS1,R1,SHE,SHEZ,SHW,SNE1,SWE,SXE SXEB,SXE4,SXE4/A,S1,VXE,VXEB,VXEB/A,V1,WKA,W1
	31232-ZE3-003	1	(1)	-	4850607	EDS1/A,LKS/A,L1/A,QXE/A,Q1/A,RSS1/A,R1/A,SHW/A,S1/A,VXE/A,W1/A EDS1/A,LKS/A,L1/A,QXE/A,Q1/A,RSS1/A,R1/A,SHW/A,S1/A,VXE/A,W1/A
21	90007-ZE2-003	BOLT-WASHER, 5X14	2	-	-	-----	EDS,EDS1,EDS1/A,EDS2,EDS2/A,EDS3,EDS5,EDS6,EDS6/A,ED3,ETS,LHE LHE4,LHE4/A,LKS,LKS/A,LNJ,LNZ,LSS5,LSS5/A,PAE,QAE,QAE2,QAE2/A QAR2,QAR2/A,QHE,QXE,QXE/A,QXEB,QXE4,QXE4/A,RHE,RHE4,RSS1,RSS1/A SHE,SHEZ,SHW,SHW/A,SNE1,SWE,SXE,SXEB,SXE4,SXE4/A,VXE,VXE/A,VXEB VXEB/A,WKA
			-	(2)	-		



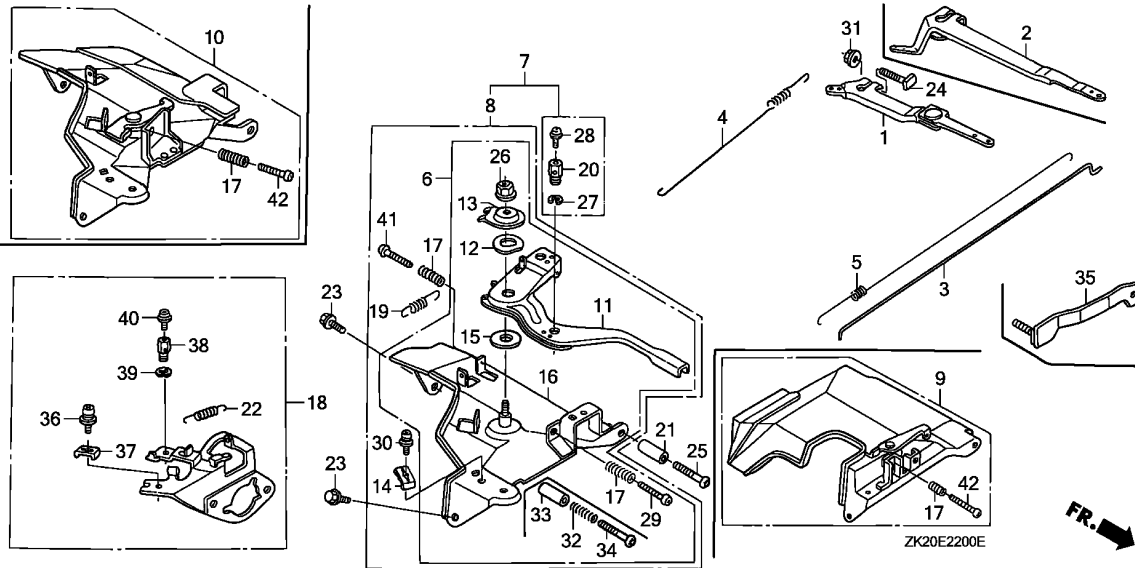

Ref. No.	L.O.N.	(Relative ref. Number) Description	F.R.T.
1		(2)	
1	1161A0	ARM, GOVERNOR	0.2
3	1161B1	ROD, GOVERNOR	0.2
4	1161C5	SPRING, GOVERNOR	0.2
5	1161C2	SPRING, THROTTLE RETURN	0.2
7		(8,9,10)	
	1161A5	CONTROL, THROTTLE/GOVERNOR ...	0.3
11	1161A8	LEVER, CONTROL	0.4
16	1161A2	BASE, CONTROL	0.4
19	1161B7	SPRING, CABLE RETURN	0.2



Ref. No.	Part No.	Description	Reqd. QTY			Serial No.	Parts catalogue code
				GX240K1			
			(1)	(2)	(3)		
1	16550-ZE2-700	ARM COMP., GOVERNOR	1	-	-	-----	EDN,EDN2,EDN2/A,EDS,EDS1,EDS1/A,EDS2,EDS2/A,EDS3,EDS5,EDS6,EDS6/A,EDT1/A,EDT2,EDT3,EDT6,EDT6/A,ED2/A,EN2,EN2/A,VAH1,VH12,VH12/A,VMT2
			1	-	-	3248151	EDT1
			1	-	-	3337057	ED2
2	16551-ZE2-000	ARM, GOVERNOR	1	-	-	-----	ED3,ED4,ED4/A,ED5,ED5/A,EN,ES,ES1,ES1/A,ES2,ES3,ES3/A,ET,ETS,ETX,HA,HAQ,HA2,HA2/A,HH,HHQ4,HHQ4/A,HTX,HX,HX/A,HXQ4,HXQ4/A,LD,LDB1,LDB3,LH,LH/A,LHE,LHE4,LHE4/A,LHZ,LJ,LJ/A,LJG,LJG/A,LJG1,LJS,LJS/A,LK,LKS,LKS/A,LM9,LNJ,LNZ,LP,LP/A,LSS4,LSS5,LSS5/A,LSX,LSX/A,LT,LT/A,LW,LX,LX/A,LXF,LXQ4,LXQ4/A,LXZ,LX2,LX2/A,PA,PAE,PA2,PA2/A,PMT2,PMT2/A,PX,PX/A,QA,QAB2,QAB2/A,QAE,QAE2,QAE2/A,QAG,QAG/A,QAG2,QAG2/A,QAQ,QAQ4,QAR2,QAR2/A,QA2,QA2/A,QC12,QC12/A,QD,QD/A,QDA,QE,QE/A,QH,QH/A,QHB2,QHC,QHE,QHP1,QHP1/A,QHQ4,QHQ4/A,QHZ,QKA2,QMH,QMH/A,QMX2,QP,QP/A,QT,QT/A,QTC2,QTC2/A,QW24,QX,QX/A,QXB,QXB7,QXB7/A,QXC,QXC/A,QXC9,QXC9/A,QXE,QXE/A,QXEB,QXE4,QXE4/A,QXQ4,QXQ4/A,QXU,QXU/A,RA,RA2,RA2/A,RD,RD/A,RH,RHE,RHE4,RHQ4,RHQ4/A,RJ,RJ/A,RSC2,RSS1,RSS1/A,RTB2,RTB2/A,RX,RX/A,RXQ4,RXQ4/A,SD,SD/A,SDB1,SDB3,SDB3/A,SE,SE/A,SH,SHE,SHEZ,SHW,SHW/A,SJ,SJ/A,SJC,SJC1,SJC1/A,SJC5,SJC5/A,SJG,SJG/A,SJP,SK,SMS,SMS/A,SMX2,SMX2/A,SNC1,SNE1,SNR,SNR/A,STP,STP/A,STQ,STQ/A,SW,SWE,SX,SX/A,SBX,SXE,SXE4,SXE4/A,SXQ4,SXQ4/A,SXU,SXU/A,VA,VA2,VA2/A,VDG2,VDG2/A,VH,VH/A,VMX,VNG,VSB1,VSB1/A,VS3,VS4,VTA,VTA2,VTA2/A,VTE2,VWC2,VWC2/A,VX,VX/A,VXB,VXB/A,VXB7,VXB7/A,VXE,VXE/A,VXEB,VXEB/A,VXQ4,VXQ4/A,VXQ7,VXQ7/A,VXU,VXU/A,VXU1,VXU1/A,WH,WJ,WJ/A,WKA,WKD6,WKD6/A,WKT2,WKT2/A,WKT4,WKT4/A,WMK
			1	-	-	3248150	EDT1
			1	-	-	3337056	ED2
			-	1	1	-----	
3	16555-ZB7-000	ROD, GOVERNOR	1	-	-	-----	EDS5

Ref. No.	Part No.	Description	Reqd. QTY			Serial No.	Parts catalogue code
			(1)	(2)	(3)		
(3)	16555-ZE2-000	ROD, GOVERNOR	1	-	-	-----	EDN,EDN2,EDN2/A,EDS,EDS1,EDS1/A,EDS2,EDS2/A,EDS3,EDS6,EDS6/A,EDT1,EDT1/A,EDT2,EDT3,EDT6,EDT6/A,ED2,ED2/A,ED3,ED4,ED4/A,ED5,ED5/A,EN,EN2,EN2/A,ES,ES1,ES1/A,ES2,ES3,ES3/A,ET,ETS,ETX,HA,HAQ,HA2,HA2/A,HH,HHQ4,HHQ4/A,HTX,HX,HX/A,HXQ4,HXQ4/A,LD,LDB1,LDB3,LH,LH/A,LHE,LHE4,LHE4/A,LHZ,LJ,LJ/A,LJG,LJG/A,LJG1,LJS,LJS/A,LK,LKS,LKS/A,LM9,LNJ,LNZ,LP,LP/A,LSS4,LSS5,LSS5/A,LSX,LSX/A,LT,LT/A,LW,LX,LX/A,LXF,LXQ4,LXQ4/A,LXZ,LX2,LX2/A,PA,PAE,PA2,PA2/A,PMT2,PMT2/A,PX,PX/A,QA,QAB2,QAB2/A,QAE,QAE2,QAE2/A,QAG,QAG/A,QAG2,QAG2/A,QAQ,QAQ4,QAR2,QAR2/A,QA2,QA2/A,QC12,QC12/A,QD,QD/A,QDA,QE,QE/A,QH,QH/A,QHB2,QHC,QHE,QHP1,QHP1/A,QHQ4,QHQ4/A,QHZ,QKA2,QMH,QMH/A,QMX2,QP,QP/A,QT,QT/A,QTC2,QTC2/A,QW24,QX,QX/A,QXB,QXB7,QXB7/A,QXC,QXC/A,QXC9,QXC9/A,QXE,QXE/A,QXEB,QXE4,QXE4/A,QXQ4,QXQ4/A,QXU,QXU/A,RA,RA2,RA2/A,RD,RD/A,RH,RHE,RHE4,RHQ4,RHQ4/A,RJ,RJ/A,RSC2,RSS1,RSS1/A,RTB2,RTB2/A,RX,RX/A,RXQ4,RXQ4/A,SD,SD/A,SDB1,SDB3,SDB3/A,SE,SE/A,SH,SHE,SHEZ,SHW,SHW/A,SJ,SJ/A,SJC,SJC1,SJC1/A,SJC5,SJC5/A,SJG,SJG/A,SJP,SK,SMS,SMS/A,SMX2,SMX2/A,SNC1,SNE1,SNR,SNR/A,STP,STP/A,STQ,STQ/A,SW,SWE,SX,SX/A,SXB,SXE,SXEB,SXE4,SXE4/A,SXQ4,SXQ4/A,SXU,SXU/A,VA,VAH1,VA2,VA2/A,VDG2,VDG2/A,VH,VH/A,VH12,VH12/A,VMT2,VMX,VNG,VSB1,VSB1/A,VS3,VS4,VTA,VTA2,VTA2/A,VTE2,VWC2,VWC2/A,VX,VX/A,VXB,VXB7,VXB7/A,VXE,VXE/A,VXEB,VXEB/A,VXQ4,VXQ4/A,VXQ7,VXQ7/A,VXU,VXU/A,VXU1,VXU1/A,WH,WJ,WJ/A,WKA,WKD6,WKD6/A,WKT2,WKT2/A,WKT4,WKT4/A,WMK
4	16561-ZE2-000	SPRING, GOVERNOR	-	1	1	-----	EDN,EDN2,EDN2/A,EDS,EDS1,EDS1/A,EDS2,EDS2/A,EDS3,EDS5,EDS6,EDS6/A,EDT1,EDT1/A,EDT2,EDT3,EDT6,EDT6/A,ED2,ED2/A,ED3,ED4,ED4/A,ED5,ED5/A,EN,EN2,EN2/A,ES,ES1,ES1/A,ES2,ES3,ES3/A,ET,ETS,ETX,HA,HAQ,HA2,HA2/A,HH,HHQ4,HHQ4/A,HTX,HX,HX/A,HXQ4,HXQ4/A,LD,LDB1,LDB3,LH,LH/A,LHE,LHE4,LHE4/A,LHZ,LJ,LJ/A,LJG,LJG/A,LJG1,LJS,LJS/A,LK,LKS,LKS/A,LM9,LNJ,LNZ,LP,LP/A,LSS4,LSS5,LSS5/A,LSX,LSX/A,LT,LT/A,LW,LX,LX/A,LXF,LXQ4,LXQ4/A,LXZ,LX2,LX2/A,PA,PAE,PA2,PA2/A,PMT2,PMT2/A,PX,PX/A,QA,QAB2,QAB2/A,QAE,QAE2,QAE2/A,QAG,QAG/A,QAQ,QAQ4,QAR2,QAR2/A,QA2,QA2/A,QC12,QC12/A,QD,QD/A,QDA,QE,QE/A,QH,QH/A,QHB2,QHC,QHE,QHP1,QHP1/A,QHQ4,QHQ4/A,QHZ,QKA2,QMH,QMH/A,QMX2,QP,QP/A,QT,QT/A,QTC2,QTC2/A,QW24,QX,QX/A,QXB,QXB7,QXB7/A,QXC,QXC/A,QXC9,QXC9/A,QXE,QXE/A,QXEB,QXE4,QXE4/A,QXQ4,QXQ4/A,QXU,QXU/A,RA,RA2,RA2/A,RD,RD/A,RH,RHE,RHE4,RHQ4,RHQ4/A,RJ,RJ/A,RSC2,RSS1,RSS1/A,RTB2,RTB2/A,RX,RX/A,RXQ4,RXQ4/A,SD,SD/A,SDB1,SDB3,SDB3/A,SE,SE/A,SH,SHE,SHEZ,SHW,SHW/A,SJ,SJ/A,SJC,SJC1,SJC1/A,SJC5,SJC5/A,SJG,SJG/A,SJP,SK,SMS,SMS/A,SMX2,SMX2/A,SNC1,SNE1,SNR,SNR/A,STP,STP/A,STQ,STQ/A,SW,SWE,SX,SX/A,SXB,SXE,SXEB,SXE4,SXE4/A,SXQ4,SXQ4/A,SXU,SXU/A,VA,VAH1,VA2,VA2/A,VDG2,VDG2/A,VH,VH/A,VMT2,VMX,VNG,VSB1,VSB1/A,VS3,VS4,VTA,VTA2,VTA2/A,VTE2,VWC2,VWC2/A,VX,VX/A,VXB,VXB7,VXB7/A,VXE,VXE/A,VXEB,VXEB/A,VXQ4,VXQ4/A,VXQ7,VXQ7/A,VXU,VXU/A,VXU1,VXU1/A,WH,WJ,WJ/A,WKA,WKD6,WKD6/A,WKT2,WKT2/A,WKT4,WKT4/A,WMK
	16561-ZE2-800	(1)	-	-	-----	3156815 VH12 ES1,ES1/A,ES2,VMX,VNG,VX,VX/A,VXB,VXB7,VXB7/A,VXQ4,VXQ4/A,VXQ7,VXQ7/A,VXU,VXU/A,VXU1,VXU1/A
	16561-ZE3-000	1	-	(1)	-----	VH12/A
			1	-	-	-----	3156816 VH12



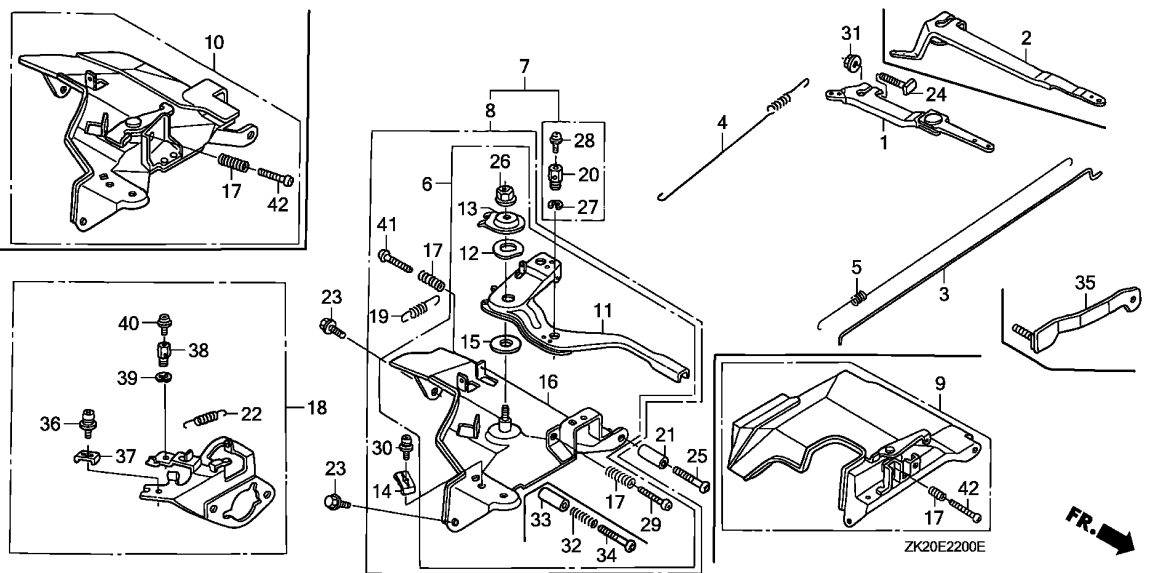

Ref. No.	Part No.	Description	Reqd. QTY			Serial No.	Parts catalogue code
			(1)	(2)	(3)		
5	16562-ZE2-000	SPRING, THROTTLE RETURN	1	-	-	-----	EDS5,ED3,ED4,ED4/A,ED5,ED5/A,EN,ES,ES1,ES1/A,ES2,ES3,ES3/A,ET,ETS ETX,HA,HAQ,HA2,HA2/A,HH,HHQ4,HHQ4/A,HTX,HX,HX/A,HXQ4,HXQ4/A,LD LDB1,LDB3,LH,LH/A,LHE,LHE4,LHE4/A,LHZ,LJ,LJ/A,LJG,LJG/A,LJG1,LJS LJS/A,LK,LKS,LKS/A,LM9,LNJ,LNZ,LP,LP/A,LSS4,LSS5,LSS5/A,LSX,LSX/A LT,LT/A,LW,LX,LX/A,LXF,LXQ4,LXQ4/A,LXZ,LX2,LX2/A,PA,PAE,PA2,PA2/A PMT2,PMT2/A,PX,PX/A,QA,QAB2,QAB2/A,QAE,QAE2,QAE2/A,QAG,QAG/A,QAG2 QAG2/A,QAQ,QAQ4,QAR2,QAR2/A,QA2,QA2/A,QC12,QC12/A,QD,QD/A,QDA,QE QE/A,QH,QH/A,QHB2,QHC,QHE,QHP1,QHP1/A,QHQ4,QHQ4/A,QHZ,QKA2,QMH QMH/A,QMX2,QP,QP/A,QT,QT/A,QTC2,QTC2/A,QW24,QX,QX/A,QXB,QXB7 QXB7/A,QXC,QXC/A,QXC9,QXC9/A,QXE,QXE/A,QXEB,QXE4,QXE4/A,QXQ4 QXQ4/A,QXU,QXU/A,RA,RA2,RA2/A,RD,RD/A,RH,RHE,RHE4,RHQ4,RHQ4/A,RJ RJ/A,RSC2,RSS1,RSS1/A,RTB2,RTB2/A,RX,RX/A,RXQ4,RXQ4/A,SD,SD/A SDB1,SDB3,SDB3/A,SE,SE/A,SH,SHE,SHEZ,SHW,SHW/A,SJ,SJ/A,SJC,SJC1 SJC1/A,SJC5,SJC5/A,SJG,SJG/A,SJP,SK,SMS,SMS/A,SMX2,SMX2/A,SNC1 SNE1,SNR,SNR/A,STP,STP/A,STQ,STQ/A,SW,SWE,SX,SX/A,AXB,SXE,SXEB SXE4,SXE4/A,SXQ4,SXQ4/A,SXU,SXU/A,VA,VA2,VA2/A,VDG2,VDG2/A,VH VH/A,VMX,VNG,VSB1,VSB1/A,VS3,VS4,VTA,VTA2,VTA2/A,VTE2,VWC2,VWC2/A VX,VX/A,VXB,VXB/A,VXB7,VXB7/A,VXE,VXE/A,VXEB,VXEB/A,VXQ4,VXQ4/A VXQ7,VXQ7/A,VXU,VXU/A,VXU1,VXU1/A,WH,WJ,WJ/A,WKA,WKD6,WKD6/A,WKT2 WKT2/A,WKT4,WKT4/A,WMK
			1	-	-	-----	EDT1
			1	-	-	-----	ED2
			-	1	1	-----	
	16562-ZE2-700	1	-	-	-----	EDN,EDN2,EDN2/A,EDS,EDS1,EDS1/A,EDS2,EDS2/A,EDS3,EDS6,EDS6/A EDT1/A,EDT2,EDT3,EDT6,EDT6/A,ED2/A,EN2,EN2/A,VAH1,VH12,VH12/A VMT2
			1	-	-	3248151	EDT1
			1	-	-	3337057	ED2

Ref. No.	Part No.	Description	Reqd. QTY			Serial No.	Parts catalogue code
			(1)	(2)	(3)		
6	16570-ZE2-W00	CONTROL ASSY.	1	-	-	HA,HAQ,HA2,HA2/A,HH,HHQ4,HHQ4/A,HX,HX/A,HXQ4,HXQ4/A,LD,LDB1,LDB3 PA,PA2,PA2/A,PMT2,PMT2/A,PX,PX/A,QD,QD/A,QDA,RD,RD/A,SD,SD/A,SDB1 SDB3,SDB3/A,SNC1,VH,VH/A,VMX,VX,VX/A,VXB,VXB/A,VXB7,VXB7/A,VXE VXE/A,VXEB,VXEB/A,VXQ4,VXQ4/A,VXQ7,VXQ7/A,WH,WMK	
	16570-ZE2-W40	-	(1)	1	VNG	
7	16570-ZE2-W10	CONTROL ASSY. (REMOTE)	1	-	-	LJ,LJ/A,LJG,LJG/A,LJG1,LJS,LJS/A,LK,LNJ,LNZ,LSS5,LSS5/A,LT,LT/A QHB2,QMX2,QTC2,QTC2/A,RJ,RJ/A,SJ,SJ/A,SJC,SJC1,SJC1/A,SJC5,SJC5/A SJG,SJG/A,SK,SMS,SMS/A,SMX2,SMX2/A,SNR,SNR/A,STP,STP/A,STQ,STQ/A WJ,WJ/A	
	16570-ZE2-W50	1	-	-	3077713 LM9	
	16570-ZK2-V40	1	-	-	HTX,QKA2,SJP	
	16570-ZK2-V60	CONTROL ASSY.	1	-	-	LSS4	
	16570-ZE2-T00	CONTROL ASSY. (GSC)	1	-	-	RSS1,RSS1/A	
			1	-	-	LKS,LKS/A	
8	16570-ZE2-W20	CONTROL ASSY. (REMOTE)	1	-	-	3077714 LM9	
			1	-	-	LH,LH/A,LHE,LHE4,LHE4/A,LHZ,LP,LP/A,LSX,LSX/A,LW,LX,LX/A,LXF,LXQ4 LXQ4/A,LXZ,LX2,LX2/A,PAE,QA,QAB2,QAB2/A,QAE,QAE2,QAE2/A,QAG,QAG/A QAG2,QAG2/A,QAQ,QAQ4,QAR2,QAR2/A,QA2,QA2/A,QC12,QC12/A,QE,QE/A,QH QH/A,QHC,QHE,QHP1,QHP1/A,QHQ4,QHQ4/A,QHZ,QMH,QMH/A,QP,QP/A,QT QT/A,QW24,QX,QX/A,QXB,QXB7,QXB7/A,QXC,QXC/A,QXC9,QXC9/A,QXE,QXE/A QXEB,QXE4,QXE4/A,QXQ4,QXQ4/A,QXU,QXU/A,RA,RA2,RA2/A,RH,RHE,RHE4 RHQ4,RHQ4/A,RSC2,RTB2,RTB2/A,RX,RX/A,RXQ4,RXQ4/A,SE,SE/A,SH,SHE SHEZ,SHW,SHW/A,SNE1,SW,SWE,SX,SX/A,SXB,SXE,SXEB,SXE4,SXE4/A,SXQ4 SXQ4/A,SXU,SXU/A,VA,VAH1,VA2,VA2/A,VTA,VTA2,VTA2/A,WKD6,WKD6/A WKT2,WKT2/A,WKT4,WKT4/A	
			1	-	-	3454257 VH12	
9	16570-ZE2-701	CONTROL ASSY.	1	-	-	EDN,EDN2,EDN2/A,ES3,ES3/A,VMT2,VSB1,VSB1/A,VS3,VS4	
	16570-ZE2-711	1	-	-	3132285 ED2	
			1	-	-	EDS,EDS1,EDS1/A,EDS2,EDS2/A,EDS3,EDS6,EDS6/A,EDT1,EDT1/A,EDT2 EDT3,EDT6,EDT6/A,ED2/A,EN2,EN2/A,VTE2	
10	16570-ZE2-721	CONTROL ASSY.	1	-	-	3132286 ED2	
			1	-	-	ED3,ED4,ED5,EN,ES,ES1,ET,ETS,ETX,VH12/A,VXU,VXU1,VXU1/A,WKA	
			1	-	-	3454258 VH12	
			1	-	-	3612528 VWC2	
	16570-ZE2-T50	CONTROL ASSY. (WACKER)	1	-	-	4812924 ED4/A,ED5/A,ES1/A,VXU/A	
			1	-	-	VDG2,VDG2/A,VWC2/A	
	16570-ZE2-722	CONTROL ASSY.	1	-	-	3612529 VWC2	
			1	-	-	ES2	
			1	-	-	4812925 ED4/A,ED5/A,ES1/A,VXU/A	



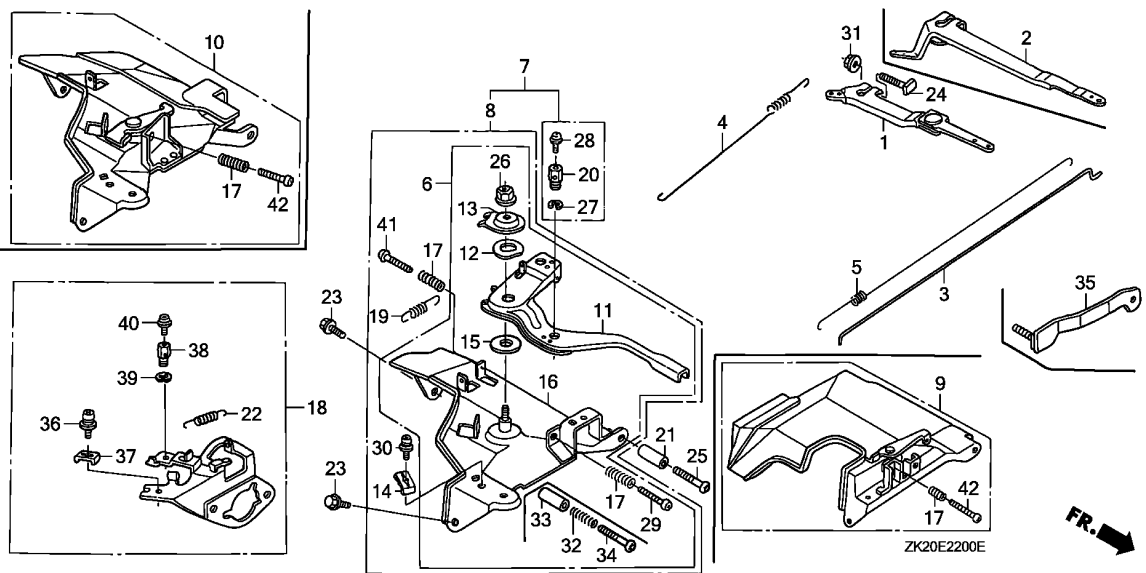

Ref. No.	Part No.	Description	Reqd. QTY			Serial No.	Parts catalogue code
			(1)	(2)	(3)		
11	16571-ZE2-W00	LEVER, CONTROL	1	-	-		HA,HAQ,HA2,HA2/A,HH,HHQ4,HHQ4/A,HTX,HX,HX/A,HXQ4,HXQ4/A,LD,LDB1,LDB3,LH,LH/A,LHE,LHE4,LHE4/A,LHZ,LJ,LJ/A,LJG,LJG/A,LJG1,LJS,LJS/A,LK,LNJ,LNZ,LP,LP/A,LSS4,LSS5,LSS5/A,LSX,LSX/A,LT,LT/A,LW,LX,LX/A,LXF,LXQ4,LXQ4/A,LXZ,LX2,LX2/A,PA,PAE,PA2,PA2/A,PMT2,PMT2/A,PX,PX/A,QA,QAB2,QAB2/A,QAE,QAE2,QAE2/A,QAG,QAG/A,QAG2,QAG2/A,QAQ,QAQ4,QAR2,QAR2/A,QA2,QA2/A,QC12,QC12/A,QD,QD/A,QDA,QE,QE/A,QH,QH/A,QHB2,QHC,QHE,QHP1,QHP1/A,QHQ4,QHQ4/A,QHZ,QKA2,QMH,QMH/A,QMX2,QP,QP/A,QT,QT/A,QTC2,QTC2/A,QW24,QX,QX/A,QXB,QXB7,QXB7/A,QXC,QXC/A,QXC9,QXC9/A,QXE,QXE/A,QXEB,QXE4,QXE4/A,QXQ4,QXQ4/A,QXU,QXU/A,RA,RA2,RA2/A,RD,RD/A,RH,RHE,RHE4,RHQ4,RHQ4/A,RJ,RJ/A,RSC2,RSS1,RSS1/A,RTB2,RTB2/A,RX,RX/A,RXQ4,RXQ4/A,SD,SD/A,SDB1,SDB3,SDB3/A,SE,SE/A,SH,SHE,SHEZ,SHW,SHW/A,SJ,SJ/A,SJC,SJC1,SJC1/A,SJC5,SJC5/A,SJG,SJG/A,SJP,SK,SMS,SMS/A,SMX2,SMX2/A,SNC1,SNE1,SNR,SNR/A,STP,STP/A,STQ,STQ/A,SW,SWE,SX,SX/A,SXB,SXE,SXE4,SXE4/A,SXQ4,SXQ4/A,SXU,SXU/A,VA,VAH1,VA2,VA2/A,VH,VH/A,VMX,VTA,VTA2,VTA2/A,VX,VX/A,VXB,VXB/A,VXB7,VXB7/A,VXE,VXE/A,VXEB,VXEB/A,VXQ4,VXQ4/A,VXQ7,VXQ7/A,WH,WJ,WJ/A,WKD6,WKD6/A,WKT2,WKT2/A,WKT4,WKT4/A,WMK
			1	-	-	3077713	LM9
			1	-	-	3454257	VH12
	16571-ZE2-W10		1	(1)	1		VNG
	16571-ZE2-A00		1	(1)	-		LKS,LKS/A
			1	-	-	3077714	LM9

Ref. No.	Part No.	Description	Reqd. QTY			Serial No.	Parts catalogue code
			(1)	(2)	(3)		
12	16574-ZE1-000	SPRING, LEVER	1	-	-	-----	HA,HAQ,HA2,HA2/A,HH,HHQ4,HHQ4/A,HTX,HX,HX/A,HXQ4,HXQ4/A,LD,LDB1 LDB3,LH,LH/A,LHE,LHE4,LHE4/A,LHZ,LJ,LJ/A,LJG,LJG/A,LJG1,LJS,LJS/A LK,LNJ,LNZ,LP,LP/A,LSS4,LSS5,LSS5/A,LSX,LSX/A,LT,LT/A,LW,LX,LX/A LXF,LXQ4,LXQ4/A,LXZ,LX2,LX2/A,PA,PAE,PA2,PA2/A,PMT2,PMT2/A,PX PX/A,QA,QAB2,QAB2/A,QAE,QAE2,QAE2/A,QAG,QAG/A,QAG2,QAG2/A,QAQ QAQ4,QAR2,QAR2/A,QA2,QA2/A,QC12,QC12/A,QD,QD/A,QDA,QE,QE/A,QH QH/A,QHB2,QHC,QHE,QHP1,QHP1/A,QHQ4,QHQ4/A,QHZ,QKA2,QMH,QMH/A,QMX2 QP,QP/A,QT,QT/A,QTC2,QTC2/A,QW24,QX,QX/A,QXB,QXB7,QXB7/A,QXC QXC/A,QXC9,QXC9/A,QXE,QXE/A,QXEB,QXE4,QXE4/A,QXQ4,QXQ4/A,QXU QXU/A,RA,RA2,RA2/A,RD,RD/A,RH,RHE,RHE4,RHQ4,RHQ4/A,RJ,RJ/A,RSC2 RSS1,RSS1/A,RTB2,RTB2/A,RX,RX/A,RXQ4,RXQ4/A,SD,SD/A,SDB1,SDB3 SDB3/A,SE,SE/A,SH,SHE,SHEZ,SHW,SHW/A,SJ,SJ/A,SJC,SJC1,SJC1/A,SJC5 SJC5/A,SJG,SJG/A,SJP,SK,SMS,SMS/A,SMX2,SMX2/A,SNC1,SNE1,SNR,SNR/A STP,STP/A,STQ,STQ/A,SW,SWE,SX,SX/A,AXB,SXE,SXEB,SXE4,SXE4/A,SXQ4 SXQ4/A,SXU,SXU/A,VA,VAH1,VA2,VA2/A,VH,VH/A,VMX,VNG,VTA,VTA2 VTA2/A,VX,VX/A,VXB,VXB/A,VXB7,VXB7/A,VXE,VXE/A,VXEB,VXEB/A,VXQ4 VXQ4/A,VXQ7,VXQ7/A,WH,WJ,WJ/A,WKD6,WKD6/A,WKT2,WKT2/A,WKT4,WKT4/A WMK
			1	-	-	-----	3077713 LM9
			-	-	-	-----	3454257 VH12
	16578-ZE1-000	SPACER, CONTROL LEVER	1	-	-	-----	LKS,LKS/A
			1	-	-	-----	3077714 LM9
13	16575-ZE2-W00	WASHER, CONTROL LEVER	1	-	-	-----	HA,HAQ,HA2,HA2/A,HH,HHQ4,HHQ4/A,HTX,HX,HX/A,HXQ4,HXQ4/A,LD,LDB1 LDB3,LH,LH/A,LHE,LHE4,LHE4/A,LHZ,LJ,LJ/A,LJG,LJG/A,LJG1,LJS,LJS/A LK,LKS,LKS/A,LM9,LNJ,LNZ,LP,LP/A,LSS4,LSS5,LSS5/A,LSX,LSX/A,LT LT/A,LW,LX,LX/A,LXF,LXQ4,LXQ4/A,LXZ,LX2,LX2/A,PA,PAE,PA2,PA2/A PMT2,PMT2/A,PX,PX/A,QA,QAB2,QAB2/A,QAE,QAE2,QAE2/A,QAG,QAG/A,QAG2 QAG2/A,QAQ,QAQ4,QAR2,QAR2/A,QA2,QA2/A,QC12,QC12/A,QD,QD/A,QDA,QE QE/A,QH,QH/A,QHB2,QHC,QHE,QHP1,QHP1/A,QHQ4,QHQ4/A,QHZ,QKA2,QMH QMH/A,QMX2,QP,QP/A,QT,QT/A,QTC2,QTC2/A,QW24,QX,QX/A,QXB,QXB7 QXB7/A,QXC,QXC/A,QXC9,QXC9/A,QXE,QXE/A,QXEB,QXE4,QXE4/A,QXQ4 QXQ4/A,QXU,QXU/A,RA,RA2,RA2/A,RD,RD/A,RH,RHE,RHE4,RHQ4,RHQ4/A,RJ RJ/A,RSC2,RSS1,RSS1/A,RTB2,RTB2/A,RX,RX/A,RXQ4,RXQ4/A,SD,SD/A SDB1,SDB3,SDB3/A,SE,SE/A,SH,SHE,SHEZ,SHW,SHW/A,SJ,SJ/A,SJC,SJC1 SJC1/A,SJC5,SJC5/A,SJG,SJG/A,SJP,SK,SMS,SMS/A,SMX2,SMX2/A,SNC1 SNE1,SNR,SNR/A,STP,STP/A,STQ,STQ/A,SW,SWE,SX,SX/A,AXB,SXE,SXEB SXE4,SXE4/A,SXQ4,SXQ4/A,SXU,SXU/A,VA,VAH1,VA2,VA2/A,VH,VH/A,VMX VNG,VTA,VTA2,VTA2/A,VX,VX/A,VXB,VXB/A,VXB7,VXB7/A,VXE,VXE/A,VXEB VXEB/A,VXQ4,VXQ4/A,VXQ7,VXQ7/A,WH,WJ,WJ/A,WKD6,WKD6/A,WKT2,WKT2/A WKT4,WKT4/A,WMK
			1	-	-	-----	3454257 VH12
			-	(1)	1		



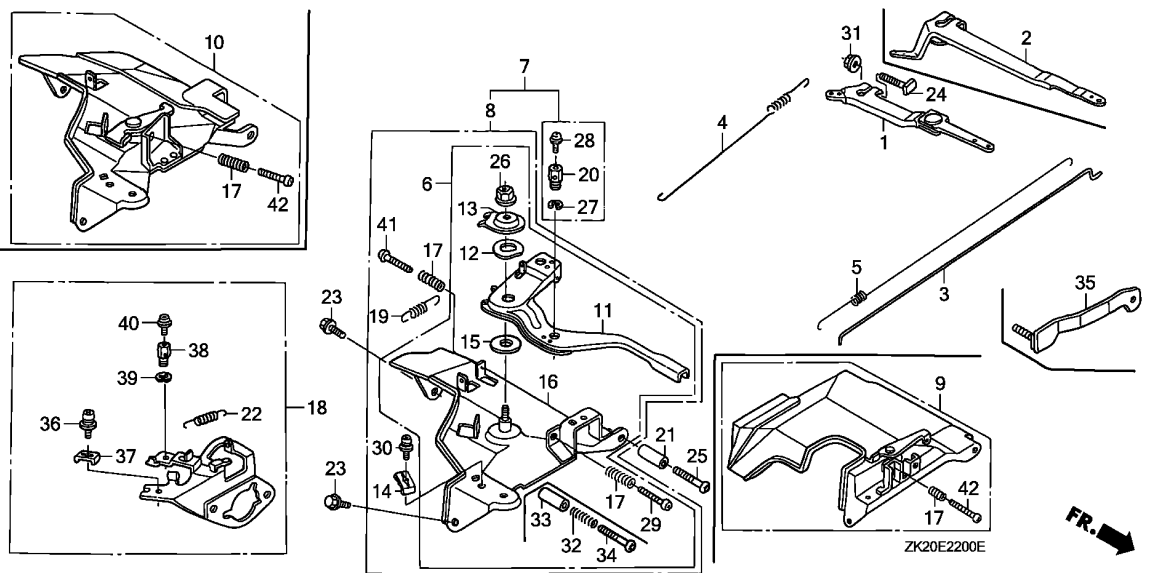

2

Ref. No.	Part No.	Description	Reqd. QTY			Serial No.	Parts catalogue code
			(1)	(2)	(3)		
14	16576-891-000	HOLDER, CABLE	1	-	-	HTX,LH,LH/A,LHE,LHE4,LHE4/A,LHZ,LJ,LJ/A,LJG,LJG/A,LJG1,LJS,LJS/A,LK,LKS,LKS/A,LM9,LNJ,LNZ,LP,LP/A,LSS4,LSS5,LSS5/A,LSX,LSX/A,LT,LT/A,LW,LX,LX/A,LXF,LXQ4,LXQ4/A,LXZ,LX2,LX2/A,PAE,QA,QAB2,QAB2/A,QAE,QAE2,QAE2/A,QAG,QAG/A,QAG2,QAG2/A,QAQ,QAQ4,QAR2,QAR2/A,QA2,QA2/A,QC12,QC12/A,QE,QE/A,QH,QH/A,QHB2,QHC,QHE,QHP1,QHP1/A,QHQ4,QHQ4/A,QHZ,QKA2,QMH,QMH/A,QMX2,QP,QP/A,QT,QT/A,QTC2,QTC2/A,QW24,QX,QX/A,QXB,QXB7,QXB7/A,QXC,QXC/A,QXC9,QXC9/A,QXE,QXE/A,QXEB,QXE4,QXE4/A,QXQ4,QXQ4/A,QXU,QXU/A,RA,RA2,RA2/A,RH,RHE,RHE4,RHQ4,RHQ4/A,RJ,RJ/A,RSC2,RSS1,RSS1/A,RTB2,RTB2/A,RX,RX/A,RXQ4,RXQ4/A,SE,SE/A,SH,SHE,SHEZ,SHW,SHW/A,SJ,SJ/A,SJC,SJC1,SJC1/A,SJC5,SJC5/A,SJG,SJG/A,SJP,SK,SMS,SMS/A,SMX2,SMX2/A,SNE1,SNR,SNR/A,STP,STP/A,STQ,STQ/A,SW,SWE,SX,SX/A,SXB,SXE,SXB,SXE4,SXE4/A,SXQ4,SXQ4/A,SXU,SXU/A,VA,VAH1,VA2,VA2/A,VTA,VTA2,VTA2/A,WJ,WJ/A,WKD6,WKD6/A,WKT2,WKT2/A,WKT4,WKT4/A	
			1	-	-	3454257 VH12	
			(1)	-	-		

Ref. No.	Part No.	Description	Reqd. QTY			Serial No.	Parts catalogue code
			(1)	(2)	(3)		
15	16578-ZE1-000	SPACER, CONTROL LEVER	1	-	-	-----	HA,HAQ,HA2,HA2/A,HH,HHQ4,HHQ4/A,HTX,HX,HX/A,HXQ4,HXQ4/A,LD,LDB1 LDB3,LH,LH/A,LHE,LHE4,LHE4/A,LHZ,LJ,LJ/A,LJG,LJG/A,LJG1,LJS,LJS/A LK,LKS,LKS/A,LM9,LNJ,LNZ,LP,LP/A,LSS4,LSS5,LSS5/A,LSX,LSX/A,LT LT/A,LW,LX,LX/A,LXF,LXQ4,LXQ4/A,LXZ,LX2,LX2/A,PA,PAE,PA2,PA2/A PMT2,PMT2/A,PX,PX/A,QA,QAB2,QAB2/A,QAE,QAE2,QAE2/A,QAG,QAG/A,QAG2 QAG2/A,QAQ,QAQ4,QAR2,QAR2/A,QA2,QA2/A,QC12,QC12/A,QD,QD/A,QDA,QE QE/A,QH,QH/A,QHB2,QHC,QHE,QHP1,QHP1/A,QHQ4,QHQ4/A,QHZ,QKA2,QMH QMH/A,QMX2,QP,QP/A,QT,QT/A,QTC2,QTC2/A,QW24,QX,QX/A,QXB,QXB7 QXB7/A,QXC,QXC/A,QXC9,QXC9/A,QXE,QXE/A,QXEB,QXE4,QXE4/A,QXQ4 QXQ4/A,QXU,QXU/A,RA,RA2,RA2/A,RD,RD/A,RH,RHE,RHE4,RHQ4/A,RJ RJ/A,RSC2,RSS1,RSS1/A,RTB2,RTB2/A,RX,RX/A,RXQ4,RXQ4/A,SD,SD/A SDB1,SDB3,SDB3/A,SE,SE/A,SH,SHE,SHEZ,SHW,SHW/A,SJ,SJ/A,SJC,SJC1 SJC1/A,SJC5,SJC5/A,SJG,SJG/A,SJP,SK,SMS,SMS/A,SMX2,SMX2/A,RJ SNE1,SNR,SNR/A,STP,STP/A,STQ,STQ/A,SW,SWE,SX,SX/A,AXB,SXE,SXEB SXE4,SXE4/A,SXQ4,SXQ4/A,SXU,SXU/A,VA,VAH1,VA2,VA2/A,VH,VH/A,VMX VNG,VTA,VTA2,VTA2/A,VX,VX/A,VXB,VXB/A,VXB7,VXB7/A,VXE,VXE/A,VXEB VXEB/A,VXQ4,VXQ4/A,VXQ7,VXQ7/A,WH,WJ,WJ/A,WKD6,WKD6/A,WKT2,WKT2/A WKT4,WKT4/A,WMK -----
			1	-	-	-----	3454257 VH12
			-	(1)	1		
16	16581-ZE2-W00	BASE COMP., CONTROL (###) ...	1	-	-	-----	HA,HAQ,HA2,HA2/A,HH,HHQ4,HHQ4/A,HTX,HX,HX/A,HXQ4,HXQ4/A,LD,LDB1 LDB3,LH,LH/A,LHE,LHE4,LHE4/A,LHZ,LJ,LJ/A,LJG,LJG/A,LJG1,LJS,LJS/A LK,LNJ,LNZ,LP,LP/A,LSS4,LSS5,LSS5/A,LSX,LSX/A,LT,LT/A,LW,LX,LX/A LXF,LXQ4,LXQ4/A,LXZ,LX2,LX2/A,PA,PAE,PA2,PA2/A,PMT2,PMT2/A,PX PX/A,QA,QAB2,QAB2/A,QAE,QAE2,QAE2/A,QAG,QAG/A,QAG2,QAG2/A,QAQ QAQ4,QAR2,QAR2/A,QA2,QA2/A,QC12,QC12/A,QD,QD/A,QDA,QE,QE/A,QH QH/A,QHB2,QHC,QHE,QHP1,QHP1/A,QHQ4,QHQ4/A,QHZ,QKA2,QMH,QMH/A,QMX2 QP,QP/A,QT,QT/A,QTC2,QTC2/A,QW24,QX,QX/A,QXB,QXB7,QXB7/A,QXC QXC/A,QXC9,QXC9/A,QXE,QXE/A,QXEB,QXE4,QXE4/A,QXQ4,QXQ4/A,QXU QXU/A,RA,RA2,RA2/A,RD,RD/A,RH,RHE,RHE4,RHQ4/A,RJ,RJ/A,RSC2 RSS1,RSS1/A,RTB2,RTB2/A,RX,RX/A,RXQ4,RXQ4/A,SD,SD/A,SDB1,SDB3 SDB3/A,SE,SE/A,SH,SHE,SHEZ,SHW,SHW/A,SJ,SJ/A,SJC,SJC1,SJC1/A,SJC5 SJC5/A,SJG,SJG/A,SJP,SK,SMS,SMS/A,SMX2,SMX2/A,SNR,SNR/A STP,STP/A,STQ,STQ/A,SW,SWE,SX,SX/A,AXB,SXE,SXEB,SXE4,SXE4/A,SXQ4 SXQ4/A,SXU,SXU/A,VA,VAH1,VA2,VA2/A,VH,VH/A,VMX,VNG,VTA,VTA2 VTA2/A,VX,VX/A,VXB,VXB/A,VXB7,VXB7/A,VXE,VXE/A,VXEB,VXEB/A,VXQ4 VXQ4/A,VXQ7,VXQ7/A,WH,WJ,WJ/A,WKD6,WKD6/A,WKT2,WKT2/A,WKT4,WKT4/A WMK -----
			1	-	-	-----	3077713 LM9
			1	-	-	-----	3454257 VH12
			-	(1)	1		
16581-ZE2-T00	BASE COMP., CONTROL (GSC) (###)		1	-	-	-----	LKS,LKS/A
			1	-	-	-----	3077714 LM9



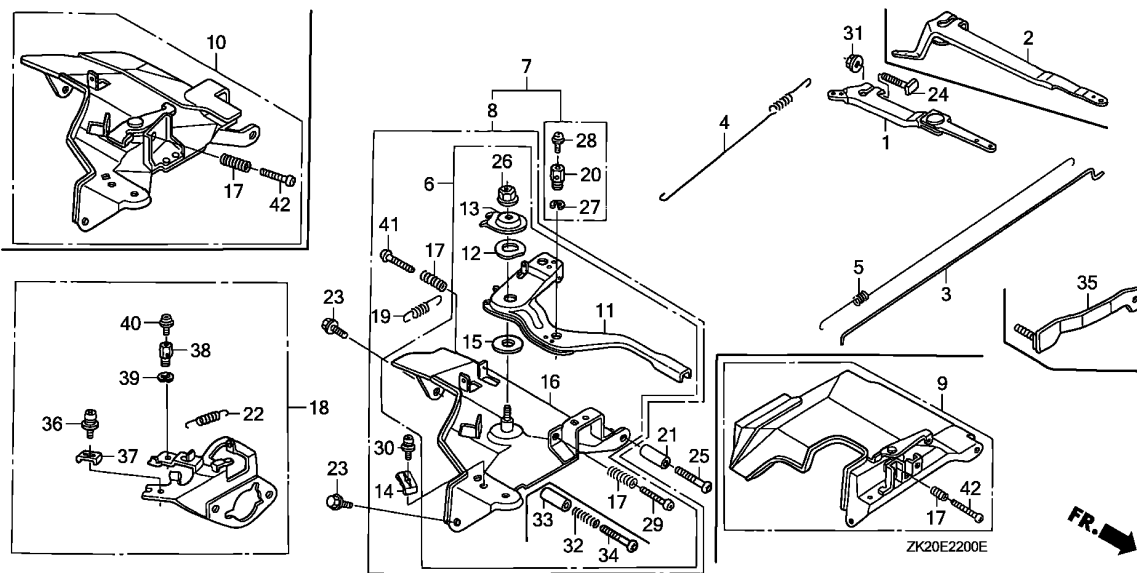

Ref. No.	Part No.	Description	Reqd. QTY			Serial No.	Parts catalogue code
			(1)	(2)	(3)		
17	16584-883-300	SPRING, CONTROL ADJUSTING ...	1	-	-	-----	EDN,EDN2,EDN2/A,EDS,EDS1,EDS1/A,EDS2,EDS2/A,EDS3,EDS6,EDS6/A,EDT1,EDT1/A,EDT2,EDT3,EDT6,EDT6/A,ED2,ED2/A,ED3,ED4,ED4/A,ED5,ED5/A,EN,EN2,EN2/A,ES,ES1,ES1/A,ES2,ES3,ES3/A,ET,ETS,ETX,HA,HAQ,HA2,HA2/A,HH,HHQ4,HHQ4/A,HTX,HX,HX/A,HXQ4,HXQ4/A,LD,LDB1,LDB3,LH,LH/A,LHE,LHE4,LHE4/A,LHZ,LJ,LJ/A,LJG,LJG/A,LJG1,LJS,LJS/A,LK,LNJ,LNZ,LP,LP/A,LSS5,LSS5/A,LSX,LSX/A,LT,LT/A,LW,LX,LX/A,LXF,LXQ4,LXQ4/A,LXZ,LX2,LX2/A,PA,PAE,PA2,PA2/A,PMT2,PMT2/A,PX,PX/A,QA,QAB2,QAB2/A,QAE,QAE2,QAE2/A,QAG,QAG/A,QAG2,QAG2/A,QAQ,QAQ4,QAR2,QAR2/A,QA2,QA2/A,QC12,QC12/A,QD,QD/A,QDA,QE,QE/A,QH,QH/A,QHB2,QHC,QHE,QHP1,QHP1/A,QHQ4,QHQ4/A,QHZ,QKA2,QMH,QMH/A,QMX2,QP,QP/A,QT,QT/A,QTC2,QTC2/A,QW24,QX,QX/A,QXB,QXB7,QXB7/A,QXC,QXC/A,QXC9,QXC9/A,QXE,QXE/A,QXE4,QXE4/A,QXQ4,QXQ4/A,QXU,QXU/A,RA,RA2,RA2/A,RD,RD/A,RH,RHE,RHE4,RHQ4,RHQ4/A,RJ,RJ/A,RSC2,RSS1,RSS1/A,RTB2,RTB2/A,RX,RX/A,RXQ4,RXQ4/A,SD,SD/A,SDB1,SDB3,SDB3/A,SE,SE/A,SH,SHE,SHEZ,SHW,SHW/A,SJ,SJ/A,SJC,SJC1,SJC1/A,SJC5,SJC5/A,SJG,SJG/A,SJP,SK,SMS,SMS/A,SMX2,SMX2/A,SNC1,SNE1,SNR,SNR/A,STP,STP/A,STQ,STQ/A,SW,SWE,SX,SX/A,SXB,SXE,SXE4,SXE4/A,SXQ4,SXQ4/A,SXU,SXU/A,VA,VAH1,VA2,VA2/A,VDG2,VDG2/A,VH,VH/A,VH12,VH12/A,VMT2,VMX,VNG,VSB1,VSB1/A,VS3,VS4,VTA,VTA2,VTA2/A,VTE2,VWC2,VWC2/A,VX,VX/A,VXB,VXB/A,VXB7,VXB7/A,VXE,VXE/A,VXEB,VXEB/A,VXQ4,VXQ4/A,VXQ7,VXQ7/A,VXU,VXU/A,VXU1,VXU1/A,WH,WJ,WJ/A,WKA,WKD6,WKD6/A,WKT2,WKT2/A,WKT4,WKT4/A,WMK
			1	-	-	-----	LM9
			2	-	-	-----	LKS,LKS/A
			-	(1)	1		
			2	-	-	3077714	----- LM9
18	16590-ZE2-812	STAY ASSY., CHOKE CONTROL (REMOTE)	1	-	-	-----	LKS,LKS/A,LNJ,LNZ,LSS5,LSS5/A,SHW,SHW/A
			-	(1)	-		

Ref. No.	Part No.	Description	Reqd. QTY			Serial No.	Parts catalogue code
			(1)	(2)	(3)		
19	16592-883-310	SPRING, CABLE RETURN	1	-	-	-----	HTX, LH, LH/A, LHE, LHE4, LHE4/A, LHZ, LJ, LJ/A, LJG, LJG/A, LJG1, LJS, LJS/A, LK, LKS, LKS/A, LM9, LNJ, LNZ, LP, LP/A, LSS4, LSS5, LSS5/A, LSX, LSX/A, LT, LT/A, LW, LX, LX/A, LXF, LXQ4, LXQ4/A, LXZ, LX2, LX2/A, PAE, QA, QAB2, QAB2/A, QAE, QAE2, QAE2/A, QAG, QAG/A, QAG2, QAG2/A, QAG, QAG4, QAR2, QAR2/A, QA2, QA2/A, QC12, QC12/A, QE, QE/A, QH, QH/A, QHB2, QHC, QHE, QHP1, QHP1/A, QHQ4, QHQ4/A, QHZ, QKA2, QMH, QMH/A, QMX2, QP, QP/A, QT, QT/A, QTC2, QTC2/A, QW24, QX, QX/A, QXB, QXB7, QXB7/A, QXC, QXC/A, QXC9, QXC9/A, QXE, QXE/A, QXEB, QXE4, QXE4/A, QXQ4, QXQ4/A, QXU, QXU/A, RA, RA2, RA2/A, RH, RHE, RHE4, RHQ4, RHQ4/A, RJ, RJ/A, RSC2, RSS1, RSS1/A, RTB2, RTB2/A, RX, RX/A, RXQ4, RXQ4/A, SE, SE/A, SH, SHE, SHEZ, SHW, SHW/A, SJ, SJ/A, SJC, SJC1, SJC1/A, SJC5, SJC5/A, SJG, SJG/A, SJP, SJP, SK, SMS, SMS/A, SMX2, SMX2/A, SNE1, SNR, SNR/A, STP, STP/A, STQ, STQ/A, SW, SWE, SX, SX/A, SXB, SXE, SXEB, SXE4, SXE4/A, SXQ4, SXQ4/A, SXU, SXU/A, VA, VAH1, VA2, VA2/A, VTA, VTA2, VTA2/A, WJ, WJ/A, WKD6, WKD6/A, WKT2, WKT2/A, WKT4, WKT4/A
			1	-	-	-----	3454257 VH12
20	16594-883-010	HOLDER, WIRE	1	-	-	-----	HTX, LJ, LJ/A, LJG, LJG/A, LJG1, LJS, LJS/A, LK, LKS, LKS/A, LM9, LNJ, LNZ, LSS4, LSS5, LSS5/A, LT, LT/A, QHB2, QKA2, QMX2, QTC2, QTC2/A, RJ, RJ/A, SJ, SJ/A, SJC, SJC1, SJC1/A, SJC5, SJC5/A, SJG, SJG/A, SJP, SJP, SK, SMS, SMS/A, SMX2, SMX2/A, SNR, SNR/A, STP, STP/A, STQ, STQ/A, WJ, WJ/A
			2	-	-	-----	RSS1, RSS1/A
21	16599-ZG1-M10	COLLAR, STOPPER	(1)	-	(1)	-----	HHQ4, HHQ4/A, HXQ4, HXQ4/A, LHE4, LHE4/A, LXQ4, LXQ4/A, QAQ4, QE/A, QHB2, QHQ4, QHQ4/A, QW24, QXB7, QXB7/A, QXE4, QXE4/A, QXQ4, QXQ4/A, RHE4, RHQ4, RHQ4/A, RXQ4, RXQ4/A, SE/A, SNC1, SNE1, SXE4, SXE4/A, SXQ4, SXQ4/A, VXB7, VXB7/A, VXQP, VXQ4, VXQ4/A, VXQ7, VXQ7/A, WKT4, WKT4/A
			(1)	-	-	-----	QE, QXB, SE, SXB
22	16615-ZE2-810	SPRING, RETURN	1	-	-	-----	LKS, LKS/A, LNJ, LNZ, LSS5, LSS5/A, SHW, SHW/A
23	90013-883-000	BOLT, FLANGE, 6X12(CT200) ...	2	-	-	-----	EDN, EDN2, EDN2/A, EDS, EDS1, EDS1/A, EDS2, EDS2/A, EDS3, EDS6, EDS6/A, EDT1, EDT1/A, EDT2, EDT3, EDT6, EDT6/A, ED2, ED2/A, ED3, ED4, ED4/A, ED5, ED5/A, EN, EN2, EN2/A, ES, ES1, ES1/A, ES2, ES3, ES3/A, ET, ETS, ETX, HA, HAQ, HA2, HA2/A, HH, HHQ4, HHQ4/A, HTX, HX, HX/A, HXQ4, HXQ4/A, LD, LDB1, LDB3, LH, LH/A, LHE, LHE4, LHE4/A, LHZ, LJ, LJ/A, LJG, LJG/A, LJG1, LJS, LJS/A, LK, LKS, LKS/A, LM9, LNJ, LNZ, LP, LP/A, LSS4, LSS5, LSS5/A, LSX, LSX/A, LT, LT/A, LW, LX, LX/A, LXF, LXQ4, LXQ4/A, LXZ, LX2, LX2/A, PA, PAE, PA2, PA2/A, PMT2, PMT2/A, PX, PX/A, QA, QAB2, QAB2/A, QAE, QAE2, QAE2/A, QAG, QAG/A, QAG2, QAG2/A, QAG, QAG4, QAR2, QAR2/A, QA2, QA2/A, QC12, QC12/A, QD, QD/A, QDA, QE, QE/A, QH, QH/A, QHB2, QHC, QHE, QHP1, QHP1/A, QHQ4, QHQ4/A, QHZ, QKA2, QMH, QMH/A, QMX2, QP, QP/A, QT, QT/A, QTC2, QTC2/A, QW24, QX, QX/A, QXB, QXB7, QXB7/A, QXC, QXC/A, QXC9, QXC9/A, QXE, QXE/A, QXEB, QXE4, QXE4/A, QXQ4, QXQ4/A, QXU, QXU/A, RA, RA2, RA2/A, RD, RD/A, RH, RHE, RHE4, RHQ4, RHQ4/A, RJ, RJ/A, RSC2, RSS1, RSS1/A, RTB2, RTB2/A, RX, RX/A, RXQ4, RXQ4/A, SD, SD/A, SDB1, SDB3, SDB3/A, SE, SE/A, SH, SHE, SHEZ, SHW, SHW/A, SJ, SJ/A, SJC, SJC1, SJC1/A, SJC5, SJC5/A, SJG, SJG/A, SJP, SJP, SK, SMS, SMS/A, SMX2, SMX2/A, SNC1, SNE1, SNR, SNR/A, STP, STP/A, STQ, STQ/A, SW, SWE, SX, SX/A, SXB, SXE, SXEB, SXE4, SXE4/A, SXQ4, SXQ4/A, SXU, SXU/A, VA, VAH1, VA2, VA2/A, VDG2, VDG2/A, VH, VH/A, VH12, VH12/A, VMT2, VMX, VNG, VSB1, VSB1/A, VS3, VS4, VTA, VTA2, VTA2/A, VTE2, VWC2, VWC2/A, VX, VX/A, VXB, VXB/A, VXB7, VXB7/A, VXE, VXE/A, VXEB, VXEB/A, VXQ4, VXQ4/A, VXQ7, VXQ7/A, VXU, VXU/A, VXU1, VXU1/A, WH, WJ, WJ/A, WKA, WKD6, WKD6/A, WKT2, WKT2/A, WKT4, WKT4/A, WMK
24	90015-ZE5-010	BOLT, GOVERNOR ARM	-	2	2		
			1	1	1		



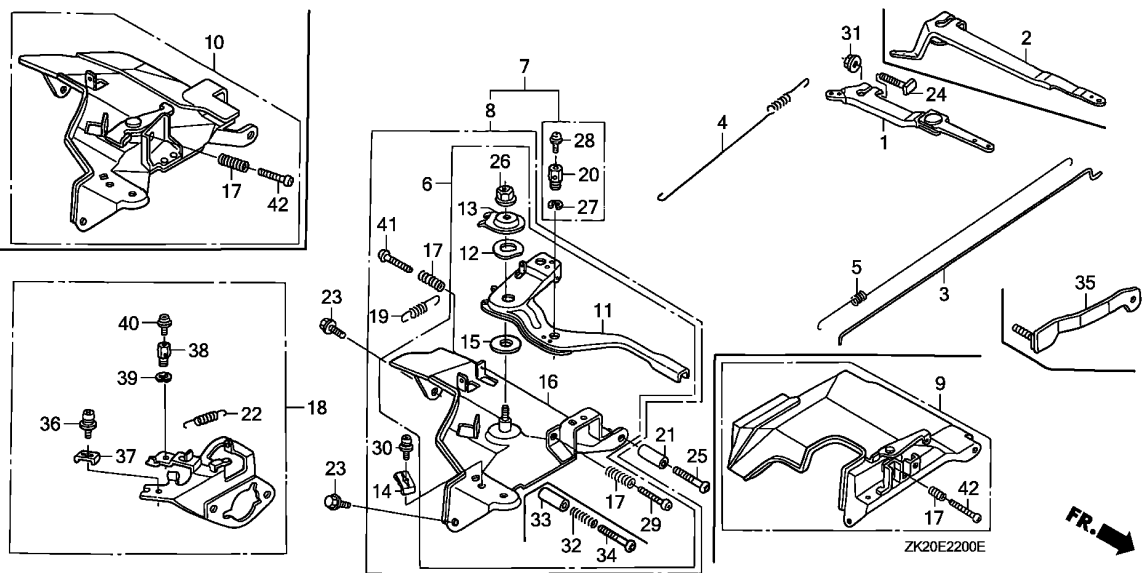

Ref. No.	Part No.	Description	Reqd. QTY			Serial No.	Parts catalogue code
			(1)	(2)	(3)		
25	90016-ZG9-N30	SCREW, RECESSED, 5X25	(1)	-	(1)		HHQ4,HHQ4/A,HXQ4,HXQ4/A,LHE4,LHE4/A,LXQ4,LXQ4/A,QAQ4,QE/A,QHB2 QHQ4,QHQ4/A,QW24,QXB7,QXB7/A,QXE4,QXE4/A,QXQ4,QXQ4/A,RHE4,RHQ4 RHQ4/A,RXQ4,RXQ4/A,SE/A,SNC1,SNE1,SXE4,SXE4/A,SXQ4,SXQ4/A,VXB7 VXB7/A,VXQP,VXQ4,VXQ4/A,VXQ7,VXQ7/A,WKT4,WKT4/A
			(1)	-	-	3302522	QE,QXB,SE,SXB
26	90114-SA0-000	NUT, SELF-LOCK, 6MM	1	-	-		HA,HAQ,HA2,HA2/A,HH,HHQ4,HHQ4/A,HTX,HX,HX/A,HXQ4,HXQ4/A,LD,LDB1 LDB3,LH,LH/A,LHE,LHE4,LHE4/A,LHZ,LJ,LJ/A,LJG,LJG/A,LJG1,LJS,LJS/A LK,LKS,LKS/A,LM9,LNJ,LNZ,LP,LP/A,LSS4,LSS5,LSS5/A,LSX,LSX/A,LT LT/A,LW,LX,LX/A,LXF,LXQ4,LXQ4/A,LXZ,LX2,LX2/A,PA,PAE,PA2,PA2/A PMT2,PMT2/A,PX,PX/A,QA,QAB2,QAB2/A,QAE,QAE2,QA2/A,QAG,QAG/A,QAG2 QAG2/A,QAQ,QAQ4,QAR2,QAR2/A,QA2,QA2/A,QC12,QC12/A,QD,QD/A,QDA,QE QE/A,QH,QH/A,QHB2,QHC,QHE,QHP1,QHP1/A,QHQ4,QHQ4/A,QHZ,QKA2,QMH QMH/A,QMX2,QP,QP/A,QT,QT/A,QTC2,QTC2/A,QW24,QX,QX/A,QXB,QXB7 QXB7/A,QXC,QXC/A,QXC9,QXC9/A,QXE,QXE/A,QXEB,QXE4,QXE4/A,QXQ4 QXQ4/A,QXU,QXU/A,RA,RA2,RA2/A,RD,RD/A,RH,RHE,RHE4,RHQ4,RHQ4/A,RJ RJ/A,RSC2,RSS1,RSS1/A,RTB2,RTB2/A,RX,RX/A,RXQ4,RXQ4/A,SD,SD/A SDB1,SDB3,SDB3/A,SE,SE/A,SH,SHE,SHEZ,SHW,SHW/A,SJ,SJ/A,SJC,SJC1 SJC1/A,SJC5,SJC5/A,SJG,SJG/A,SJP,SK,SMS,SMS/A,SMX2,SMX2/A,SNC1 SNE1,SNR,SNR/A,STP,STP/A,STQ,STQ/A,SW,SWE,SX,SX/A,SXB,SXE,SXEB SXE4,SXE4/A,SXQ4,SXQ4/A,SXU,SXU/A,VA,VAH1,VA2,VA2/A,VH,VH/A,VMX VNG,VTA,VTA2,VTA2/A,VX,VX/A,VXB,VXB/A,VXB7,VXB7/A,VXE,VXE/A,VXEB VXEB/A,VXQ4,VXQ4/A,VXQ7,VXQ7/A,WH,WJ,WJ/A,WKD6,WKD6/A,WKT2,WKT2/A WKT4,WKT4/A,WMK
			1	-	-	3454257	VH12
			-	(1)	1		

Ref. No.	Part No.	Description	Reqd. QTY			Serial No.	Parts catalogue code
			(1)	(2)	(3)		
27	90605-230-000	CIRCLIP, 5MM	1	-	-	HTX,LJ,LJ/A,LJG,LJG/A,LJG1,LJS,LJS/A,LK,LKS,LKS/A,LM9,LNJ,LNZ LSS4,LSS5,LSS5/A,LT,LT/A,QHB2,QKA2,QMX2,QTC2,QTC2/A,RJ,RJ/A,SJ SJ/A,SJC,SJC1,SJC1/A,SJC5,SJC5/A,SJG,SJG/A,SJP,SK,SMS,SMS/A,SMX2 SMX2/A,SNR,SNR/A,STP,STP/A,STQ,STQ/A,WJ,WJ/A	
			2	-	-	RSS1,RSS1/A	
			-	(1)	-		
28	93500-04006-0H	SCREW, PAN, 4X6	1	-	-	HTX,LJ,LJ/A,LJG,LJG/A,LJG1,LJS,LJS/A,LK,LKS,LKS/A,LM9,LNJ,LNZ LSS4,LSS5,LSS5/A,LT,LT/A,QHB2,QKA2,QMX2,QTC2,QTC2/A,RJ,RJ/A,SJ SJ/A,SJC,SJC1,SJC1/A,SJC5,SJC5/A,SJG,SJG/A,SJP,SK,SMS,SMS/A,SMX2 SMX2/A,SNR,SNR/A,STP,STP/A,STQ,STQ/A,WJ,WJ/A	
			2	-	-	RSS1,RSS1/A	
			-	(1)	-		
29	93500-05028-0A	SCREW, PAN, 5X28	1	-	-	HA,HAQ,HA2,HA2/A,HH,HHQ4,HHQ4/A,HTX,HX,HX/A,HXQ4,HXQ4/A,LD,LDB1 LDB3,LH,LH/A,LHE,LHE4,LHE4/A,LHZ,LJ,LJ/A,LJG,LJG/A,LJG1,LJS,LJS/A LK,LNJ,LNZ,LP,LP/A,LSS5,LSS5/A,LSX,LSX/A,LT,LT/A,LW,LX,LX/A,LXF LXQ4,LXQ4/A,LXZ,LX2,LX2/A,PA,PAE,PA2,PA2/A,PMT2,PMT2/A,PX,PX/A,QA QAB2,QAB2/A,QAE,QAE2,QAE2/A,QAG,QAG/A,QAG2,QAG2/A,QAQ,QAQ4,QAR2 QAR2/A,QA2,QA2/A,QC12,QC12/A,QD,QD/A,QDA,QE,QE/A,QH,QH/A,QHB2,QHC QHE,QHP1,QHP1/A,QHQ4,QHQ4/A,QHZ,QKA2,QMH,QMH/A,QMX2,QP,QP/A,QT QT/A,QTC2,QTC2/A,QW24,QX,QX/A,QXB,QXB7,QXB7/A,QXC,QXC/A,QXC9 QXC9/A,QXE,QXE/A,QXEB,QXE4,QXE4/A,QXQ4,QXQ4/A,QXU,QXU/A,RA,RA2 RA2/A,RD,RD/A,RH,RHE,RHE4,RHQ4,RHQ4/A,RJ,RJ/A,RSC2,RSS1,RSS1/A RTB2,RTB2/A,RX,RX/A,RXQ4,RXQ4/A,SD,SD/A,SDB1,SDB3,SDB3/A,SE,SE/A SH,SHE,SHEZ,SHW,SHW/A,SJ,SJ/A,SJC,SJC1,SJC1/A,SJC5,SJC5/A,SJG SJG/A,SJP,SK,SMS,SMS/A,SMX2,SMX2/A,SNC1,SNE1,SNR,SNR/A,STP,STP/A STQ,STQ/A,SW,SWE,SX,SX/A,SXB,SXE,SXEB,SXE4,SXE4/A,SXQ4,SXQ4/A,SXU SXU/A,VA,VAH1,VA2,VA2/A,VH,VH/A,VMX,VNG,VTA,VTA2,VTA2/A,VX,VX/A VXB,VXB/A,VXB7,VXB7/A,VXE,VXE/A,VXEB,VXEB/A,VXQ4,VXQ4/A,VXQ7 VXQ7/A,WH,WJ,WJ/A,WKD6,WKD6/A,WKT2,WKT2/A,WKT4,WKT4/A,WMK	
			1	-	-	3077713 LM9	
			1	-	-	3454257 VH12	
			-	(1)	1		
	90121-735-700	SCREW, LOCK PAN (5X35)	1	-	-	LKS,LKS/A	
			1	-	-	LM9	
30	93500-05016-0A	SCREW, PAN, 5X16	1	-	-	HTX,LH,LH/A,LHE,LHE4,LHE4/A,LHZ,LJ,LJ/A,LJG,LJG/A,LJG1,LJS,LJS/A LK,LKS,LKS/A,LM9,LNJ,LNZ,LP,LP/A,LSS4,LSS5,LSS5/A,LSX,LSX/A,LT LT/A,LW,LX,LX/A,LXF,LXQ4,LXQ4/A,LXZ,LX2,LX2/A,PAE,QA,QAB2,QAB2/A QAE,QAE2,QAE2/A,QAG,QAG/A,QAG2,QAG2/A,QAQ,QAQ4,QAR2,QAR2/A,QA2 QA2/A,QC12,QC12/A,QE,QE/A,QH,QH/A,QHB2,QHC,QHE,QHP1,QHP1/A,QHQ4 QHQ4/A,QHZ,QKA2,QMH,QMH/A,QMX2,QP,QP/A,QT,QT/A,QTC2,QTC2/A,QW24 QX,QX/A,QXB,QXB7,QXB7/A,QXC,QXC/A,QXC9,QXC9/A,QXE,QXE/A,QXEB,QXE4 QXE4/A,QXQ4,QXQ4/A,QXU,QXU/A,RA,RA2,RA2/A,RH,RHE,RHE4,RHQ4,RHQ4/A RJ,RJ/A,RSC2,RSS1,RSS1/A,RTB2,RTB2/A,RX,RX/A,RXQ4,RXQ4/A,SE,SE/A SH,SHE,SHEZ,SHW,SHW/A,SJ,SJ/A,SJC,SJC1,SJC1/A,SJC5,SJC5/A,SJG SJG/A,SJP,SK,SMS,SMS/A,SMX2,SMX2/A,SNE1,SNR,SNR/A,STP,STP/A,STQ STQ/A,SW,SWE,SX,SX/A,SXB,SXE,SXEB,SXE4,SXE4/A,SXQ4,SXQ4/A,SXU SXU/A,VA,VAH1,VA2,VA2/A,VTA,VTA2,VTA2/A,WJ,WJ/A,WKD6,WKD6/A,WKT2 WKT2/A,WKT4,WKT4/A	
			1	-	-	3454257 VH12	
			-	(1)	-		
31	94050-06000	NUT, FLANGE, 6MM	1	1	1		
32	16584-883-300	SPRING, CONTROL ADJUSTING ...	1	-	-	LSS4	
33	16599-ZG1-M10	COLLAR, STOPPER	1	-	-	LSS4	
34	90016-ZG9-N30	SCREW, RECESSED, 5X25	1	-	-	LSS4	
35	16558-ZE2-U60	ARM COMP., SUB GOVERNOR (MEIJI)	1	-	-	SJC5,SJC5/A,SMS,SMS/A,SNR,SNR/A	



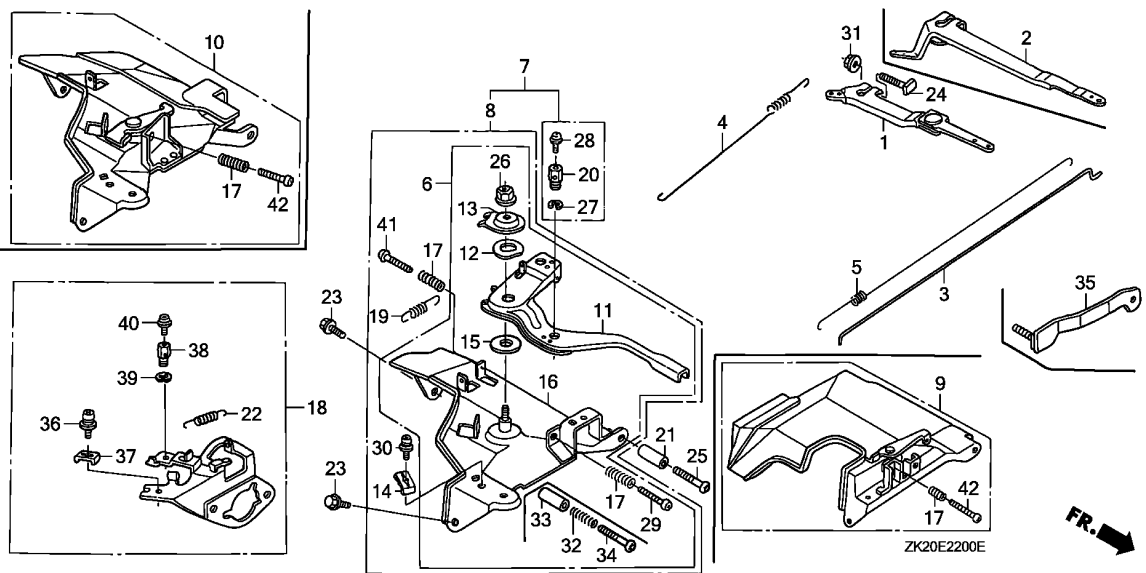

Ref. No.	Part No.	Description	Reqd. QTY			Serial No.	Parts catalogue code
			(1)	(2)	(3)		
36	93893-05016-00	SCREW-WASHER, 5X16	1	-	-	LKS,LKS/A, LNJ, LNZ, LSS5, LSS5/A, SHW, SHW/A	
37	16576-891-000	HOLDER, CABLE	1	-	-	LKS,LKS/A, LNJ, LNZ, LSS5, LSS5/A, SHW, SHW/A	
38	16594-883-010	HOLDER, WIRE	1	-	-	LKS,LKS/A, LNJ, LNZ, LSS5, LSS5/A, SHW, SHW/A	
39	90605-230-000	CIRCLIP, 5MM	1	-	-	LKS,LKS/A, LNJ, LNZ, LSS5, LSS5/A, SHW, SHW/A	
40	93500-04006-0H	SCREW, PAN, 4X6	1	-	-	LKS,LKS/A, LNJ, LNZ, LSS5, LSS5/A, SHW, SHW/A	
41	93500-05028-0A	SCREW, PAN, 5X28	1	-	-	LKS,LKS/A	
42	93500-05035-0A	SCREW, PAN, 5X35	1	-	-	LM9	
			1	-	-	EDN,EDN2,EDN2/A,EDS,EDS1,EDS1/A,EDS2,EDS2/A,EDS3,EDS6,EDS6/A,EDT1,EDT1/A,EDT2,EDT3,EDT6,EDT6/A,ED2,ED2/A,ED3,ED4,ED4/A,ED5,ED5/A,EN,EN2,EN2/A,ES,ES1,ES1/A,ES2,ES3,ES3/A,ET,ETS,ETX,VH12/A,VMT2,VSB1, VSB1/A,VS3,VS4,VTE2,VXU,VXU/A,VXU1,VXU1/A,WKA	
			1	-	-	3454258 VH12	
			1	-	-	3612528 VWC2	
	93500-05028-0H	SCREW, PAN, 5X28	1	-	-	VDG2,VDG2/A,VWC2/A	
			1	-	-	3612529 VWC2	

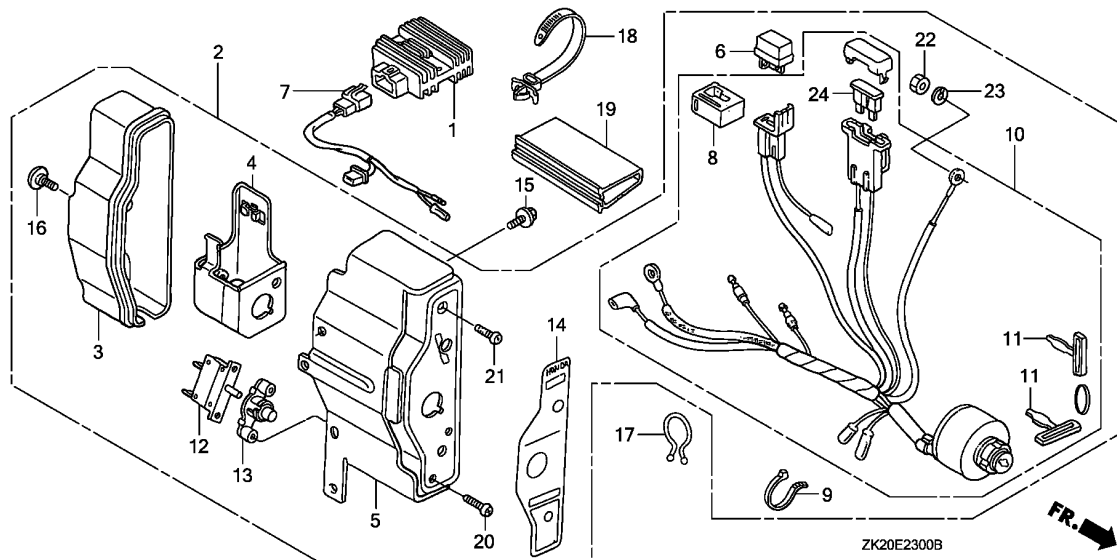

Ref. No.	L.O.N.	(Relative ref. Number) Description	F.R.T.
1	6131B7	RECTIFIER, REGULATOR	0.2
2	6221N7	BOX, ENGINE CONTROL	0.1
5	6151K5	PANEL, ENGINE CONTROL	0.2
6	6131B8	RECTIFIER, SILICON	0.1
7	6111E6	HARNESS, REGULATOR RECTIFIER	0.2
10	6151E1	SWITCH, COMBINATION	0.2
12	6221D4	PROTECTOR, CIRCUIT	0.2
24	8121A7	FUSE, BLADE	0.1

Ref. No.	Part No.	Description	Reqd. QTY			Serial No.	Parts catalogue code
			(1)	(2)	(3)		
1	31600-ZE2-861	RECTIFIER ASSY., REGULATOR (10A)	-	(1)	-		
2	31610-ZE2-013ZB	BOX ASSY., CONTROL (INTERNAL) *R8*.....BRIGHT RED	1	(1)	-	L1,P1,Q1,RSS1,R1,S1,V1,W1	
	31610-ZE2-013ZD	*R280*.....POWER RED	1	(1)	-	4464507 L1/A,Q1/A,RSS1/A,R1/A,S1/A,W1/A	
3	31612-ZE2-003	CASE, CONTROL	1	(1)	-	4464508 L1/A,Q1/A,RSS1/A,R1/A,S1/A,W1/A	
4	31614-ZE2-003	BRACKET, CASE MOUNTING	1	(1)	-	RSS1,RSS1/A	
5	31615-ZE2-003ZB	PANEL COMP., CONTROL *R8*.....BRIGHT RED	1	(1)	-	L1,P1,Q1,RSS1,R1,S1,V1,W1	
	31615-ZE2-003ZG	*R280*.....POWER RED	1	(1)	-	4464507 L1/A,Q1/A,RSS1/A,R1/A,S1/A,W1/A	
			1	(1)	-	4464508 L1/A,Q1/A,RSS1/A,R1/A,S1/A,W1/A	
6	31700-124-008	RECTIFIER ASSY., SILICON (SHINDENGEN)	1	(1)	-	RSS1,RSS1/A	
7	32110-ZE2-860	HARNESS ASSY., SUB WIRE	1	(1)	-	RSS1,RSS1/A	
8	32127-738-700	SUSPENSION, COUPLER	1	(1)	-	RSS1,RSS1/A	
9	32902-892-003	BAND	1	(1)	-	RSS1,RSS1/A	
10	35100-ZE2-023	SWITCH ASSY., COMBINATION	1	(1)	-	L1,P1,Q1,RSS1,R1,S1,V1,W1	
	35100-ZE2-033		1	(1)	-	4853656 L1/A,Q1/A,RSS1/A,R1/A,S1/A,W1/A	
			1	(1)	-	4853657 L1/A,Q1/A,RSS1/A,R1/A,S1/A,W1/A	
11	35111-880-003	KEY COMP.	2	(2)	-	L1,P1,Q1,RSS1,R1,S1,V1,W1	
			2	(2)	-	4593890 L1/A,Q1/A,RSS1/A,R1/A,S1/A,W1/A	



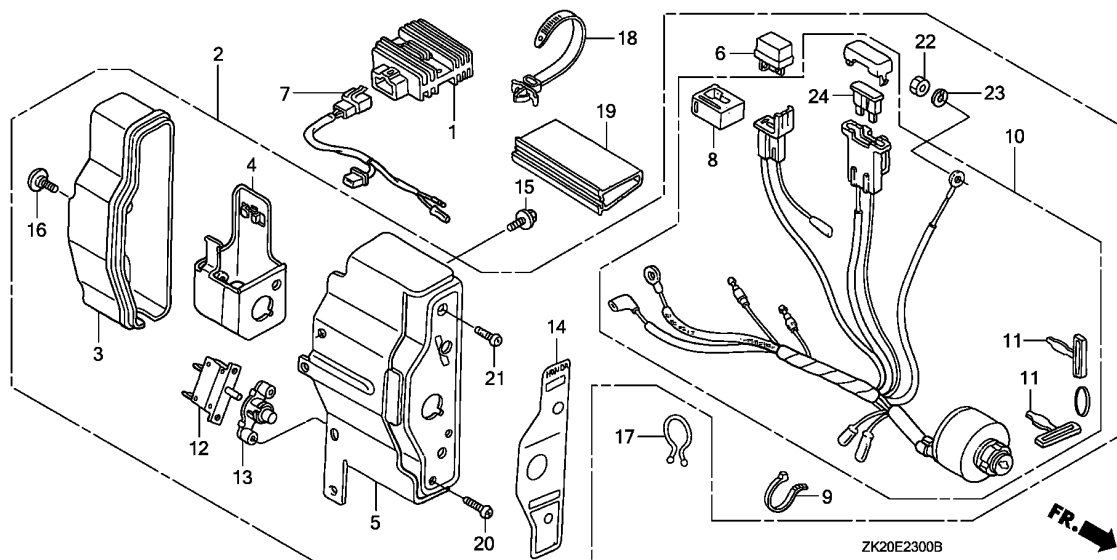

Ref. No.	Part No.	Description	Reqd. QTY			Serial No.	Parts catalogue code
			(1)	(2)	(3)		
11)	35111-880-013	KEY COMP.	2	(2)	-	4593891	L1/A,Q1/A,RSS1/A,R1/A,S1/A,W1/A
12	38240-VA3-900	PROTECTOR, CIRCUIT (1.0A) ...	1	-	-	-	RSS1,RSS1/A
13	38250-ZA8-701	LENS ASSY., PROTECTOR	1	(1)	-	-	RSS1,RSS1/A
14	87529-ZE2-010	PANEL, CONTROL BOX (INTERNAL)	1	(1)	-	-	L1,P1,Q1,Q1/A,RSS1,R1,S1,V1,W1,W1/A
	87529-ZE2-020	1	(1)	-	4524995	L1/A,RSS1/A,R1/A,S1/A
15	90013-883-000	BOLT, FLANGE, 6X12(CT200) ...	2	-	-	4524996	L1/A,RSS1/A,R1/A,S1/A
			-	(2)	-	-	RSS1,RSS1/A
16	90380-MA6-010	SCREW, SPECIAL, 6X12	1	-	-	-	RSS1,RSS1/A
			-	(1)	-	-	RSS1,RSS1/A
17	90630-751-000	CLIP, PURSE LOCK	1	-	-	-	RSS1,RSS1/A
			-	(1)	-	-	RSS1,RSS1/A
18	90672-SA0-003	STRAP, CABLE, 118MM(BLACK) ..	1	-	-	-	RSS1,RSS1/A
			-	(1)	-	-	RSS1,RSS1/A
19	91406-ZE2-003	TUBE, FASTENER, 30MM	1	-	-	-	RSS1,RSS1/A
			-	(1)	-	-	RSS1,RSS1/A
20	93500-03012-0H	SCREW, PAN, 3X12	2	-	-	-	RSS1,RSS1/A
			-	(2)	-	-	RSS1,RSS1/A
21	93500-04012-0H	SCREW, PAN, 4X12	1	-	-	-	RSS1,RSS1/A
			-	(1)	-	-	RSS1,RSS1/A
22	94001-04390-0S	NUT, HEX., 4MM	1	-	-	-	RSS1,RSS1/A
			-	(1)	-	-	RSS1,RSS1/A
23	94111-04800	WASHER, SPRING, 4MM	1	-	-	-	RSS1,RSS1/A
			-	(1)	-	-	RSS1,RSS1/A
24	98200-30500	FUSE, BLADE (5A)	1	-	-	-	RSS1,RSS1/A
			-	(1)	-	-	RSS1,RSS1/A

2

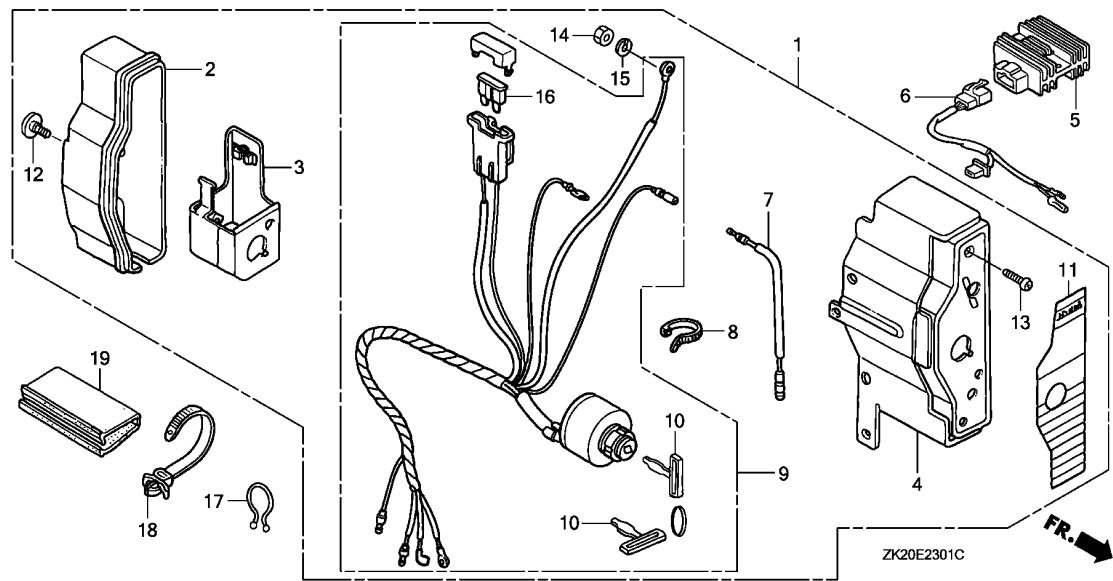

Ref. No.	L.O.N.	(Relative ref. Number) Description	F.R.T.
1	6221N7	BOX, ENGINE CONTROL	0.1
4	6151K5	PANEL, ENGINE CONTROL.	0.2
5	6131B7	RECTIFIER, REGULATOR	0.2
6	6111E6	HARNESS, REGULATOR RECTIFIER ..	0.2
9	6151E1	SWITCH, COMBINATION	0.2
16	8121A7	FUSE, BLADE	0.1

Ref. No.	Part No.	Description	Reqd. QTY			Serial No.	Parts catalogue code
			(1)	(2)	(3)		
1	31610-ZE2-862ZB	BOX ASSY., CONTROL (10A)	1	(1)	-	-	-
		R8.....BRIGHT RED	1	(1)	-	4466592	LSS5,L1,P1,Q1,R1,V1,W1
	31610-ZK9-W41ZA	*R8*.....BRIGHT RED	1	-	-	-	SNE1
	31610-ZE2-862ZD	*R280*.....POWER RED	1	(1)	-	4466593	LSS5/A,L1/A,Q1/A,R1/A,W1/A
2	31612-ZE2-003	CASE, CONTROL	1	(1)	-	-	LSS5,LSS5/A,L1,L1/A,P1,Q1,Q1/A,R1,R1/A,SNE1,V1,W1,W1/A
3	31614-ZE2-003	BRACKET, CASE MOUNTING	1	(1)	-	-	LSS5,LSS5/A,L1,L1/A,P1,Q1,Q1/A,R1,R1/A,SNE1,V1,W1,W1/A
4	31615-ZE2-003ZB	PANEL COMP., CONTROL	1	(1)	-	-	LSS5,L1,P1,Q1,R1,SNE1,V1,W1
		R8.....BRIGHT RED	1	(1)	-	4466592	LSS5/A,L1/A,Q1/A,R1/A,W1/A
	31615-ZE2-003ZG	*R280*.....POWER RED	1	(1)	-	4466593	LSS5/A,L1/A,Q1/A,R1/A,W1/A
5	31600-ZE2-861	RECTIFIER ASSY., REGULATOR (10A)	1	-	-	-	SNE1
6	32110-ZE2-860	HARNESS ASSY., SUB WIRE	1	-	-	-	SNE1
7	32197-ZE1-003	SUB HARNESS	1	-	-	-	SNE1
8	32902-892-003	BAND	1	(1)	-	-	LSS5,LSS5/A,L1,L1/A,P1,Q1,Q1/A,R1,R1/A,SNE1,V1,W1,W1/A
9	35100-ZE2-862	SWITCH ASSY., COMBINATION (10A-CHARGE)	1	(1)	-	-	LSS5,LSS5/A,L1,L1/A,P1,Q1,Q1/A,R1,R1/A,SNE1,V1,W1,W1/A
10	35111-880-003	KEY COMP.	2	(2)	-	-	LSS5,L1,P1,Q1,R1,SNE1,V1,W1
			2	(2)	-	4593890	LSS5/A,L1/A,Q1/A,R1/A,W1/A
	35111-880-013		2	(2)	-	4593891	LSS5/A,L1/A,Q1/A,R1/A,W1/A
11	87529-ZE2-860	MARK, CONTROL BOX (EXTERNAL-REGULATOR)	1	(1)	-	-	LSS5,L1,L1/A,P1,Q1,R1,R1/A,V1,W1,W1/A
			1	(1)	-	4533388	LSS5/A,Q1/A
	87529-ZH8-W40	MARK, CONTROL BOX (ENGLISH) ..	1	-	-	-	SNE1
	87529-ZE2-861	MARK, CONTROL BOX (EXTERNAL-REGULATOR)	1	(1)	-	4533389	LSS5/A,Q1/A



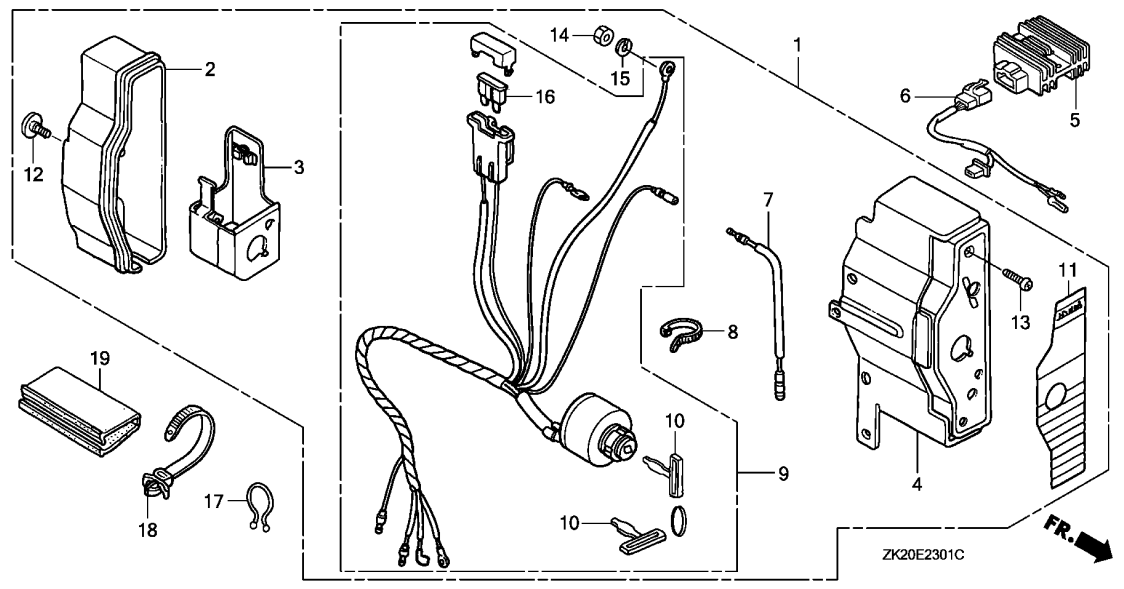

Ref. No.	Part No.	Description	Reqd. QTY			Serial No.	Parts catalogue code
			(1)	(2)	(3)		
			GX240K1				
12	90380-MA6-010	SCREW, SPECIAL, 6X12	1	(1)	-	-----	LSS5,LSS5/A,L1,L1/A,P1,Q1,Q1/A,R1,R1/A,SNE1,V1,W1,W1/A
13	93500-04012-OH	SCREW, PAN, 4X12	1	(1)	-	-----	LSS5,LSS5/A,L1,L1/A,P1,Q1,Q1/A,R1,R1/A,SNE1,V1,W1,W1/A
14	94001-04390-0S	NUT, HEX., 4MM	1	(1)	-	-----	LSS5,LSS5/A,L1,L1/A,P1,Q1,Q1/A,R1,R1/A,SNE1,V1,W1,W1/A
15	94111-04800	WASHER, SPRING, 4MM	1	(1)	-	-----	LSS5,LSS5/A,L1,L1/A,P1,Q1,Q1/A,R1,R1/A,SNE1,V1,W1,W1/A
16	98200-31500	FUSE, BLADE (15A)	1	(1)	-	-----	LSS5,LSS5/A,L1,L1/A,P1,Q1,Q1/A,R1,R1/A,SNE1,V1,W1,W1/A
17	90630-751-000	CLIP, PURSE LOCK	1	-	-	-----	SNE1
18	90672-SA0-003	STRAP, CABLE, 118MM(BLACK)	1	-	-	-----	SNE1
19	91406-ZE2-003	TUBE, FASTENER, 30MM	1	-	-	-----	SNE1

2

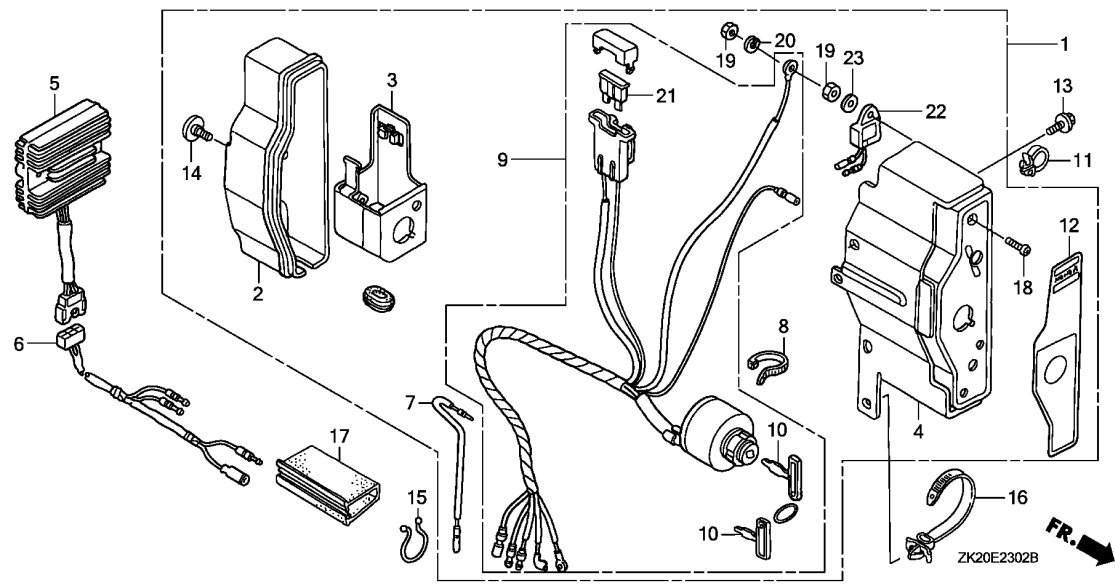

Ref. No.	L.O.N.	(Relative ref. Number) Description	F.R.T.
1	6221N7	BOX, ENGINE CONTROL	0.1
4	6151K5	PANEL, ENGINE CONTROL.	0.2
5	6131B7	RECTIFIER, REGULATOR	0.2
6	6111E6	HARNES, REGULATOR RECTIFIER .	0.2
9	6151E1	SWITCH, COMBINATION	0.2
21	8121A7	FUSE, BLADE	0.1

Ref. No.	Part No.	Description	Reqd. QTY			Serial No.	Parts catalogue code
			(1)	(2)	(3)		
1	31610-ZE2-W01ZA	BOX ASSY., CONTROL (EXTERNAL-ALERT) (18A)	1	-	-	-----	3684578 QAR2
	NH1BLACK	1	-	-	-----	3684578 QAR2
	31610-ZE2-W01ZC	*R8*.....BRIGHT RED	1	-	-	-----	3684578 QAR2
	31610-ZE2-W02ZA	BOX ASSY., CONTROL (EXP-ALERT) (18A)	-	(1)	-	3202450	3684578 L1,P1,Q1,R1,S1,V1,W1
	NH1BLACK	1	-	-	-----	QAR2/A
	31610-ZE2-W02ZC	*R8*.....BRIGHT RED	1	(1)	-	3684579	QAR2
			1	(1)	-	3684579	L1,P1,QAR2,Q1,R1,S1,V1,W1
	31610-ZE2-W02ZE	*R280*.....POWER RED	1	-	-	-----	4487961 QAR2/A
			1	(1)	-	-----	4464507 L1/A,Q1/A,R1/A,S1/A,W1/A
			1	-	-	4487962	QAR2/A
			1	(1)	-	4464508	L1/A,Q1/A,R1/A,S1/A,W1/A
2	31612-ZE2-003	CASE, CONTROL	1	(1)	-	-----	L1/A,QAR2,QAR2/A,Q1/A,R1/A,S1/A,W1/A
			1	(1)	-	3202450	L1,P1,Q1,R1,S1,V1,W1
3	31614-ZE2-003	BRACKET, CASE MOUNTING	1	(1)	-	-----	L1/A,QAR2,QAR2/A,Q1/A,R1/A,S1/A,W1/A
			1	(1)	-	3202450	L1,P1,Q1,R1,S1,V1,W1
4	31615-ZE2-003ZB	PANEL COMP., CONTROL	1	-	-	-----	QAR2
	R8BRIGHT RED	1	-	-	-----	4487962 QAR2/A
			1	(1)	-	3202450	L1,P1,Q1,R1,S1,V1,W1
	31615-ZE2-003ZG	*R280*.....POWER RED	1	-	-	-----	4464507 L1/A,Q1/A,R1/A,S1/A,W1/A
			1	(1)	-	4487963	QAR2/A
			1	(1)	-	4464508	L1/A,Q1/A,R1/A,S1/A,W1/A
5	31620-ZG5-003	RECTIFIER ASSY., REGULATOR (20A)	1	-	-	-----	QAR2
			1	(1)	-	3202450	L1,P1,Q1,R1,S1,V1,W1



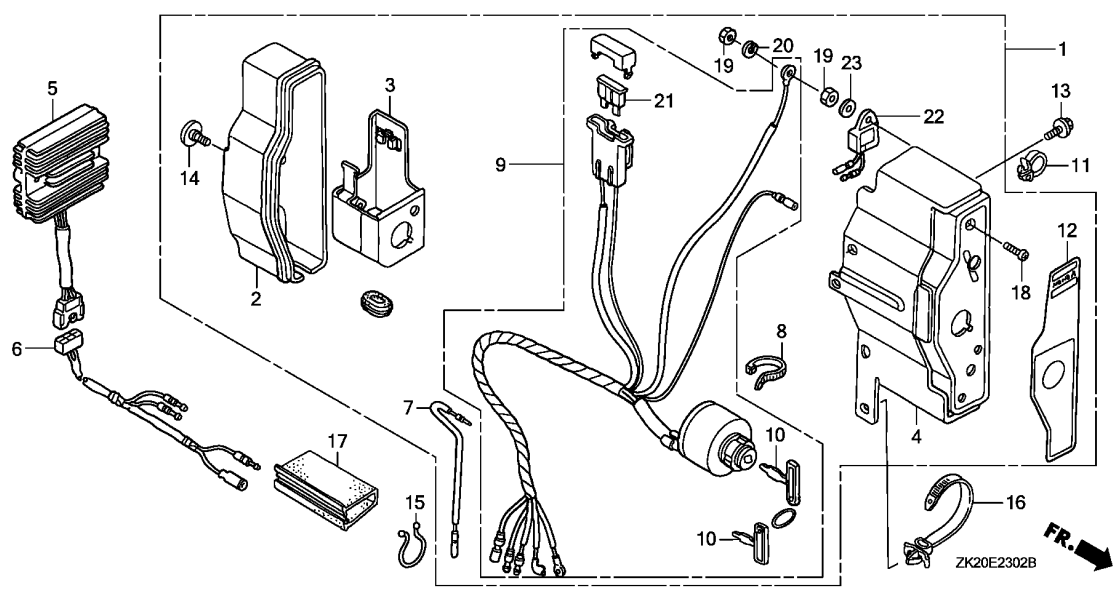

Ref. No.	Part No.	Description	Reqd. QTY			Serial No.	Parts catalogue code
			(1)	(2)	(3)		
(5)	31620-ZG5-013	RECTIFIER ASSY., REGULATOR (20A)	1	-	-	-----	QAR2/A
	31620-ZG5-023	-	(1)	-	4845214	L1/A,Q1/A,R1/A,S1/A,W1/A
6	32110-ZE2-W00	HARNESS ASSY., SUB WIRE	1	(1)	-	-----	L1/A,QAR2,QAR2/A,Q1/A,R1/A,S1/A,W1/A
			-	(1)	-	3202450	L1,P1,Q1,R1,S1,V1,W1
7	32197-ZE1-003	SUB HARNESS	1	(1)	-	-----	L1/A,QAR2,QAR2/A,Q1/A,R1/A,S1/A,W1/A
			-	(1)	-	3202450	L1,P1,Q1,R1,S1,V1,W1
8	32902-892-003	BAND	1	(1)	-	-----	L1/A,QAR2,QAR2/A,Q1/A,R1/A,S1/A,W1/A
			-	(1)	-	3202450	L1,P1,Q1,R1,S1,V1,W1
9	35100-ZE2-W01	SWITCH ASSY., COMBINATION (18A-CHARGE)	1	(1)	-	-----	L1/A,QAR2,QAR2/A,Q1/A,R1/A,S1/A,W1/A
			-	(1)	-	3202450	L1,P1,Q1,R1,S1,V1,W1
10	35111-880-003	KEY COMP.	2	(2)	-	4593890	L1/A,QAR2/A,Q1/A,R1/A,S1/A,W1/A
			2	-	-	-----	QAR2
	35111-880-013	2	(2)	-	4593891	L1,P1,Q1,R1,S1,V1,W1
			-	(2)	-	4593891	L1/A,QAR2/A,Q1/A,R1/A,S1/A,W1/A
11	36103-ZE1-000	HOLDER, STOP SWITCH CORD	1	(1)	-	-----	L1/A,QAR2,QAR2/A,Q1/A,R1/A,S1/A,W1/A
			-	(1)	-	3202450	L1,P1,Q1,R1,S1,V1,W1
12	87529-ZE2-860	MARK, CONTROL BOX (EXTERNAL-REGULATOR)	1	(1)	-	-----	L1/A,QAR2,R1/A,W1/A
			1	(1)	-	4533388	QAR2/A,Q1/A,S1/A
			-	(1)	-	3202450	L1,P1,Q1,R1,S1,V1,W1
	87529-ZE2-861	1	(1)	-	4533389	QAR2/A,Q1/A,S1/A
13	90013-883-000	BOLT, FLANGE, 6X12(CT200) ...	2	(2)	-	-----	L1/A,QAR2,QAR2/A,Q1/A,R1/A,S1/A,W1/A
			-	(2)	-	3202450	L1,P1,Q1,R1,S1,V1,W1



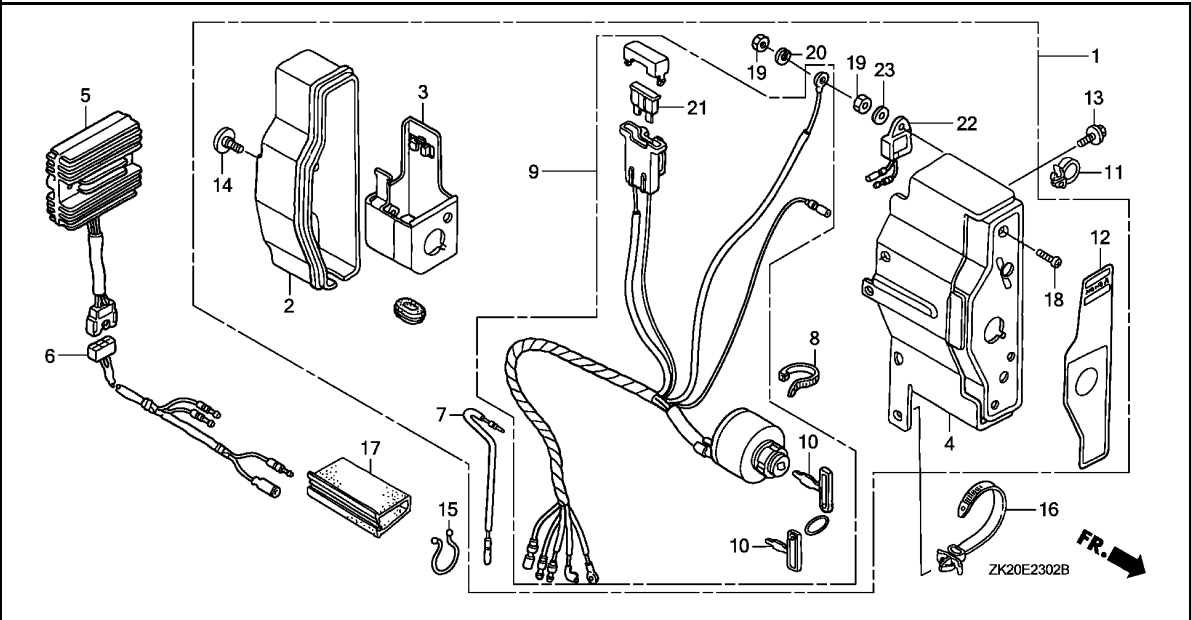

Ref. No.	Part No.	Description	Reqd. QTY			Serial No.	Parts catalogue code
			(1)	(2)	(3)		
14	90380-MA6-010	SCREW, SPECIAL, 6X12	1	(1)	-	L1/A,QAR2,QAR2/A,Q1/A,R1/A,S1/A,W1/A	
15	90630-751-000	CLIP, PURSE LOCK	1	(1)	-	L1,P1,Q1,R1,S1,V1,W1	
16	90672-SA0-003	STRAP, CABLE, 118MM(BLACK)	1	(1)	-	L1/A,QAR2,QAR2/A,Q1/A,R1/A,S1/A,W1/A	
17	91406-ZE2-003	TUBE, FASTENER, 30MM	1	(1)	-	L1,P1,Q1,R1,S1,V1,W1	
18	93500-04012-0H	SCREW, PAN, 4X12	1	(1)	-	L1/A,QAR2,QAR2/A,Q1/A,R1/A,S1/A,W1/A	
19	94001-04390-0S	NUT, HEX., 4MM	1	-	-	L1,P1,Q1,R1,S1,V1,W1	
20	94111-04800	WASHER, SPRING, 4MM	1	(1)	-	3684578 QAR2	
21	98200-32500	FUSE, BLADE (25A)	1	(1)	-	3684578 L1,P1,Q1,R1,S1,V1,W1	
22	34150-ZH7-003	ALERT UNIT, OIL	1	(1)	-	L1/A,QAR2/A,Q1/A,R1/A,S1/A,W1/A	
	34150-ZH7-013		1	(1)	-	3684579 L1,P1,QAR2,Q1,R1,S1,V1,W1	
23	94101-04800	WASHER, PLAIN, 4MM	1	(1)	-	4853039 Q1/A,S1/A,W1/A	
			1	(1)	-	4853040 Q1/A,S1/A,W1/A	
			1	(1)	-	L1/A,QAR2/A,Q1/A,R1/A,S1/A,W1/A	
			1	(1)	-	3684579 L1,P1,QAR2,Q1,R1,S1,V1,W1	

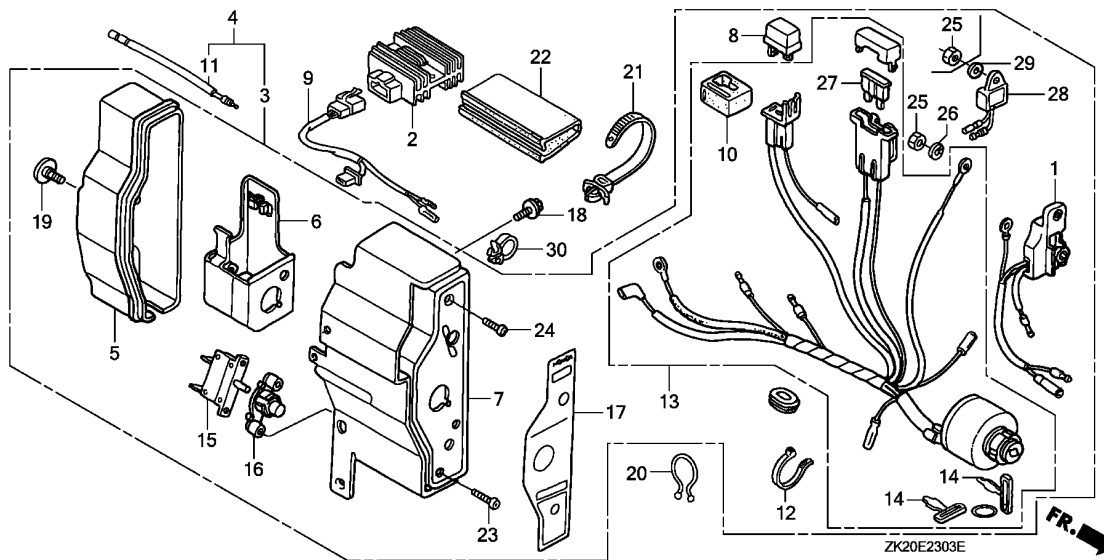

Ref. No.	L.O.N.	(Relative ref. Number) Description	F.R.T.
1	6151K4	ALERT UNIT, ENGINE CONTROL OIL (3)	0.2
4	6221N7	BOX, ENGINE CONTROL	0.1
7	6151K5	PANEL, ENGINE CONTROL	0.2
8	6131B8	RECTIFIER, SILICON	0.1
9	6111E6	HARNESS, REGULATOR RECTIFIER	0.2
13	6151E1	SWITCH, COMBINATION	0.2
15	6221D4	PROTECTOR, CIRCUIT	0.2
27	8121A7	FUSE, BLADE	0.1

2

Ref. No.	Part No.	Description	Reqd. QTY			Serial No.	Parts catalogue code
			(1)	(2)	(3)		
1	15520-ZE2-822	ALERT UNIT, OIL (SEL)	1	(1)	-	3116814	L1,P1,QAE,QXE,QXEB,Q1,R1,SXE,SXEB,VXE,VXEB,V1,W1
2	31600-ZE2-861	RECTIFIER ASSY., REGULATOR (10A)	1	-	-	-	ETS
3	31610-ZE2-812ZB	BOX ASSY., CONTROL	1	(1)	-	-	L1,L1/A,PAE,P1,Q1,Q1/A,R1,R1/A,V1,W1,W1/A
		R8.....BRIGHT RED	1	-	-	-	3320786 LKS
	31610-ZE2-822ZB	BOX ASSY., CONTROL (INTERNAL-ALERT)	1	(1)	-	-	ED3,LHE,L1,P1,QHE,Q1,RHE,R1,SHE,SHEZ,SWE,V1,W1
		R8.....BRIGHT RED	-	(1)	-	-	4466592 L1/A,Q1/A,R1/A,W1/A
	31610-ZE2-832ZB	BOX ASSY., CONTROL (ALERT)	1	(1)	-	-	3116814 L1,P1,R1,V1,W1
		R8.....BRIGHT RED	1	(1)	-	-	3116814 L1,P1,QXE,QXEB,Q1,R1,SXE,SXEB,VXE,VXEB,V1,W1
	31610-ZE2-842ZB	BOX ASSY., CONTROL (3A)	-	(1)	-	-	L1,P1,Q1,R1,V1,W1
		R8.....BRIGHT RED	-	(1)	-	-	4466592 L1/A,Q1/A,R1/A,W1/A
	31610-ZE2-852ZB	BOX ASSY., CONTROL (EXP-ALERT) (3A)	1	(1)	-	-	3116814 L1,P1,QAE,Q1,R1,V1,W1
		R8.....BRIGHT RED	1	(1)	-	-	3116814 L1,P1,Q1,R1,V1,W1
	31610-ZE2-872ZB	BOX ASSY., CONTROL (EXP-ALERT) (10A)	1	-	-	-	4464540 LHE4,RHE4
		R8.....BRIGHT RED	1	-	-	-	4464540 LHE4/A
	31610-ZE2-812ZD	*R280*.....POWER RED	-	(1)	-	4466593	L1/A,Q1/A,R1/A,W1/A
	31610-ZE2-842ZD	BOX ASSY., CONTROL (3A)	-	(1)	-	4466593	L1/A,Q1/A,R1/A,W1/A
		R280.....POWER RED	-	(1)	-	-	L1/A,Q1/A,R1/A,W1/A

Ref. No.	Part No.	Description	Reqd. QTY			Serial No.	Parts catalogue code
			(1)	(2)	(3)		
(3)	31610-ZK2-W41ZC	BOX ASSY., CONTROL *R280*.....POWER RED	1	-	-	4464541	----- LHE4/A
4	31610-ZE2-823ZB	BOX ASSY., CONTROL *R8*.....BRIGHT RED	-	(1)	-	3116815	3684578 L1,P1,R1,V1,W1
	31610-ZE2-833ZB	*R8*.....BRIGHT RED	1	(1)	-	3116815	3684578 L1,P1,QXE,Q1,R1,VXE,VXEB,V1,W1
	31610-ZE2-853ZA	BOX ASSY., CONTROL (EXTERNAL-ALERT) (3A)	1	-	-	-----	3684578 QAE2
	31610-ZE2-853ZB	*NH1*.....BLACK	1	-	-	3116815	----- QAE
		R8.....BRIGHT RED	1	-	-	-----	3684578 QAE2
			-	(1)	-	3116815	3684578 L1,P1,Q1,R1,V1,W1
	31610-ZE2-873ZA	BOX ASSY., CONTROL (10A)	-	(1)	-	3116815	3684578 Q1
	31610-ZE2-873ZB	*NH1*.....BLACK	1	-	-	-----	PAE
		R8.....BRIGHT RED	-	(1)	-	3116815	3684578 L1,P1,Q1,R1,V1,W1
	31610-ZH9-W51ZA	BOX ASSY., CONTROL *R8*.....BRIGHT RED	1	-	-	-----	3684578 QXE4,SXE4
	31610-ZE2-824ZB	*R8*.....BRIGHT RED	-	(1)	-	3684579	----- L1,P1,R1,V1,W1
			-	(1)	-	-----	4466592 L1/A,R1/A,W1/A
	31610-ZE2-834ZB	*R8*.....BRIGHT RED	1	(1)	-	3684579	----- L1,P1,QXE,Q1,R1,VXE,VXEB,V1,W1
			1	-	-	-----	4464114 QXE/A,VXE/A,VXEB/A
			-	(1)	-	-----	4466592 L1/A,Q1/A,R1/A,W1/A
	31610-ZE2-854ZA	BOX ASSY., CONTROL (EXP-ALERT) (3A)	1	-	-	-----	QAE2/A
		NH1.....BLACK	1	-	-	3684579	----- QAE2
	31610-ZE2-854ZB	*R8*.....BRIGHT RED	1	(1)	-	3684579	----- L1,P1,QAE2,Q1,R1,V1,W1
			1	-	-	-----	4463352 QAE2/A
			-	(1)	-	-----	4466592 L1/A,Q1/A,R1/A,W1/A
	31610-ZE2-874ZA	BOX ASSY., CONTROL (10A)	-	(1)	-	-----	Q1/A
		NH1.....BLACK	-	(1)	-	3684579	----- Q1
	31610-ZE2-874ZB	*R8*.....BRIGHT RED	-	(1)	-	3684579	----- L1,P1,Q1,R1,V1,W1
			-	(1)	-	-----	4464507 L1/A,Q1/A,R1/A,W1/A
	31610-ZH9-W52ZA	BOX ASSY., CONTROL (ALERT) *R8*.....BRIGHT RED	1	-	-	3684579	----- QXE4,SXE4
			1	-	-	-----	4464508 QXE4/A,SXE4/A
	31610-ZE2-824ZE	BOX ASSY., CONTROL *R280*.....POWER RED	-	(1)	-	4466593	----- L1/A,R1/A,S1/A,W1/A
	31610-ZE2-834ZE	BOX ASSY., CONTROL (EXP-ALERT) *R280*.....POWER RED	1	-	-	4464115	----- QXE/A,VXE/A,VXEB/A
			-	(1)	-	4466593	----- L1/A,Q1/A,R1/A,W1/A
	31610-ZE2-854ZF	BOX ASSY., CONTROL (EXP-ALERT) (3A)	1	-	-	4463353	----- QAE2/A
		R280.....POWER RED	-	(1)	-	4466593	----- L1/A,Q1/A,R1/A,W1/A
	31610-ZE2-874ZD	BOX ASSY., CONTROL (10A) *R280*.....POWER RED	-	(1)	-	4464508	----- L1/A,Q1/A,R1/A,S1/A,W1/A
	31610-ZH9-W52ZC	BOX ASSY., CONTROL (ALERT) *R280*.....POWER RED	1	-	-	4464509	----- QXE4/A,SXE4/A
5	31612-ZE2-003	CASE, CONTROL	1	(1)	-	-----	ED3,LHE,LHE4,LHE4/A,L1,L1/A,PAE,P1,QAE,QAE2,QAE2/A,QHE,QXE,QXE/A,QXEB,QXE4,QXE4/A,Q1,Q1/A,RHE,RHE4,R1,R1/A,SHE,SHEZ,SWE,SXE,SXEB,SXE4,SXE4/A,VXE,VXE/A,VXEB,VXEB/A,V1,W1,W1/A

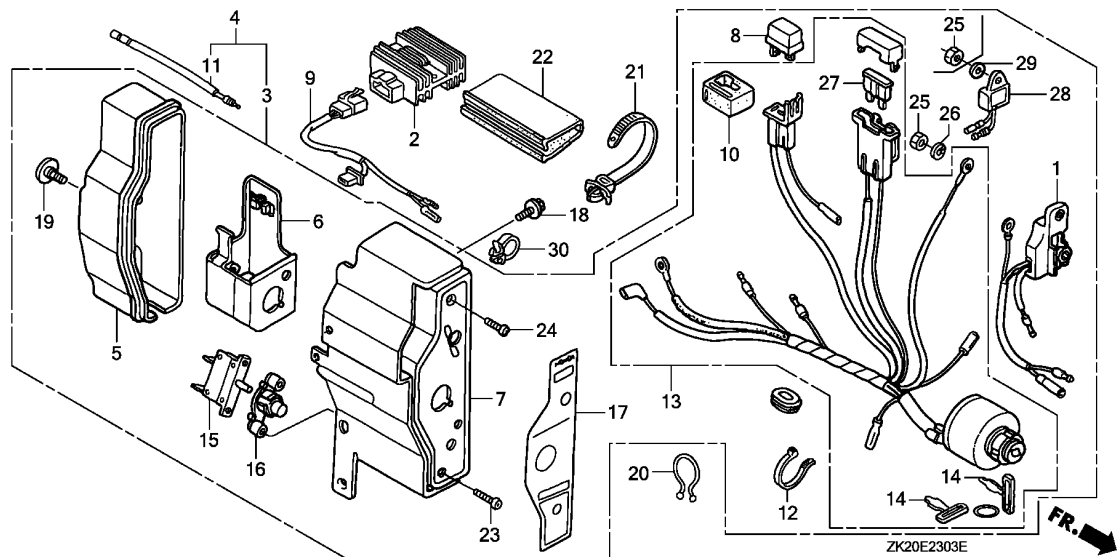

Ref. No.	Part No.	Description	Reqd. QTY			Serial No.	Parts catalogue code
			(1)	(2)	(3)		
6	31614-ZE2-003	BRACKET, CASE MOUNTING	1	(1)	-	ED3,ETS,LHE,LHE4,LHE4/A,L1,L1/A,PAE,P1,QAE,QAE2,QAE2/A,QHE,QXE,QXE/A,QXEB,QXE4,QXE4/A,Q1,Q1/A,RHE,RHE4,R1,R1/A,SHE,SHEZ,SWE,SXE,SXEB,SXE4,SXE4/A,VXE,VXE/A,VXEB,VXEB/A,V1,W1,W1/A	
7	31615-ZE2-003ZA	PANEL COMP., CONTROL	1	-	-	3320786	LKS
	NH1BLACK	1	-	-		QAE2,QAE2/A
	31615-ZE2-003ZB	*R8*.....BRIGHT RED	1	(1)	-		ED3,LHE,LHE4,L1,PAE,P1,QAE,QAE2,QHE,QXE,QXEB,QXE4,Q1,RHE,RHE4,R1,SHE,SHEZ,SWE,SXE,SXEB,V1,W1
			1	(1)	-	4463352	L1/A,QAE2/A,Q1/A,R1/A,W1/A
			1	-	-	4464114	QXE/A,VXE/A,VXEB/A
			1	-	-	4464508	QXE4/A,SXE4/A
			1	-	-	4464540	LHE4/A
	31615-ZE2-003ZG	*R280*.....POWER RED	1	(1)	-	4463353	L1/A,QAE2/A,Q1/A,R1/A,S1/A,W1/A
			1	-	-	4464115	QXE/A,VXE/A,VXEB/A
			1	-	-	4464509	QXE4/A,SXE4/A
			1	-	-	4464541	LHE4/A
8	31700-124-008	RECTIFIER ASSY., SILICON (SHINDENGEN)	1	(1)	-		ED3,ETS,LHE,LHE4,LHE4/A,L1,L1/A,P1,QAE,QAE2,QAE2/A,QHE,QXE,QXE/A,QXEB,QXE4,QXE4/A,Q1,Q1/A,RHE,RHE4,R1,R1/A,SHE,SHEZ,SWE,SXE,SXEB,SXE4,SXE4/A,VXE,VXE/A,VXEB,VXEB/A,V1,W1,W1/A
9	32110-ZE2-860	HARNESS ASSY., SUB WIRE	1	(1)	-		L1,L1/A,PAE,P1,Q1,Q1/A,R1,R1/A,V1,W1,W1/A
			1	-	-	3320786	LKS
10	32127-738-700	SUSPENSION, COUPLER	1	(1)	-		ED3,ETS,LHE,LHE4,LHE4/A,L1,L1/A,P1,QAE,QAE2,QAE2/A,QHE,QXE,QXE/A,QXEB,QXE4,QXE4/A,Q1,Q1/A,RHE,RHE4,R1,R1/A,SHE,SHEZ,SWE,SXE,SXEB,SXE4,SXE4/A,VXE,VXE/A,VXEB,VXEB/A,V1,W1,W1/A
11	32197-ZE1-003	SUB HARNESS	1	(1)	-		L1/A,PAE,QAE2,QAE2/A,QXE/A,QXE4,QXE4/A,Q1/A,R1/A,SXE4,SXE4/A,VXE/A,VXEB/A,W1/A
			1	(1)	-	3116815	L1,P1,QAE,QXE,QXEB,Q1,R1,SXE,SXEB,VXE,VXEB,V1,W1

Ref. No.	Part No.	Description	Reqd. QTY			Serial No.	Parts catalogue code
			(1)	(2)	(3)		
12	32902-892-003	BAND	1	(1)	-	ED3,LHE,LHE4,LHE4/A,LKS,L1,L1/A,PAE,P1,QAE,QAE2,QAE2/A,QHE,QXE,QXE/A,QXEB,QXE4,QXE4/A,Q1,Q1/A,RHE,RHE4,R1,R1/A,SHE,SHEZ,SWE,SXE,SXEB,SXE4,SXE4/A,VXE,VXE/A,VXEB,VXEB/A,V1,W1,W1/A	
13	35100-ZE2-023	SWITCH ASSY., COMBINATION ...	1	(1)	-	ED3,ETS,LHE,LHE4,LHE4/A,L1,P1,QHE,QXE,QXEB,QXE4,Q1,RHE,RHE4,R1,SHE,SHEZ,SWE,SXE,SXEB,SXE4,SXE4/A,VXE,VXEB,VXEB/A,V1,W1	
	35100-ZE2-842	SWITCH ASSY., COMBINATION (3A-CHARGE)	1	(1)	-	4853656 L1/A,QXE/A,Q1/A,R1/A,VXE/A,W1/A	
	35100-ZE2-862	SWITCH ASSY., COMBINATION (10A-CHARGE)	1	(1)	-	L1,P1,QAE,QAE2,QAE2/A,Q1,R1,V1,W1	
	35100-ZE2-033	SWITCH ASSY., COMBINATION ...	1	-	-	3320786 L1,L1/A,PAE,P1,Q1,Q1/A,R1,R1/A,V1,W1,W1/A	
	35100-ZE2-843	SWITCH ASSY., COMBINATION (3A-CHARGE)	1	(1)	-	4853657 LKS	
14	35111-880-003	KEY COMP.	2	(2)	-	L1/A,Q1/A,R1/A,W1/A	
			2	(2)	-	ED3,LHE,LHE4,LHE4/A,L1,PAE,P1,QAE,QAE2,QHE,QXE,QXEB,QXE4,Q1,RHE,RHE4,R1,SHEZ,SWE,SXE,SXEB,SXE4,VXE,VXEB,V1,W1	
			2	(2)	-	4593890 LHE4/A,L1/A,QAE2/A,QXE/A,QXE4/A,Q1/A,R1/A,SXE4/A,VXE/A,VXEB/A,W1/A	
			2	-	-	3320786 LKS	
			2	-	-	4604960 ED3,LHE,SHE	
	35111-880-013	2	(2)	-	4593891 LHE4/A,L1/A,QAE2/A,QXE/A,QXE4/A,Q1/A,R1/A,SXE4/A,VXE/A,VXEB/A,W1/A	
15	38240-VA3-900	PROTECTOR, CIRCUIT (1.0A) ...	2	-	-	4604961 ED3,LHE,SHE	
			1	(1)	-	ED3,ETS,LHE,LHE4,LHE4/A,L1,L1/A,P1,QHE,QXE,QXE/A,QXEB,QXE4,QXE4/A,Q1,Q1/A,RHE,RHE4,R1,R1/A,SHE,SHEZ,SWE,SXE,SXEB,SXE4,SXE4/A,VXE,VXE/A,VXEB,VXEB/A,V1,W1,W1/A	
	38240-ZE2-840	PROTECTOR, CIRCUIT (3.5A) ...	1	(1)	-	L1,L1/A,P1,QAE,QAE2,QAE2/A,Q1,Q1/A,R1,R1/A,V1,W1,W1/A	
	38240-898-000	PROTECTOR, CIRCUIT (D.C.) ...	1	-	-	LKS	
16	38250-ZA8-701	LENS ASSY., PROTECTOR	1	(1)	-	ED3,ETS,LHE,LHE4,LHE4/A,LKS,L1,L1/A,P1,QAE,QAE2,QAE2/A,QHE,QXE,QXE/A,QXEB,QXE4,QXE4/A,Q1,Q1/A,RHE,RHE4,R1,R1/A,SHE,SHEZ,SWE,SXE,SXEB,SXE4,SXE4/A,VXE,VXE/A,VXEB,VXEB/A,V1,W1,W1/A	
17	87529-ZE2-821	PANEL, CONTROL BOX (INTERNAL-ALERT)	-	(1)	-	3116814 L1,P1,R1,V1,W1	
	87529-ZE2-831	PANEL, CONTROL BOX (EXTERNAL-ALERT)	1	(1)	-	3116814 L1,P1,QAE,QXE,QXEB,Q1,R1,SXE,SXEB,VXE,VXEB,V1,W1	
	87529-ZE2-870	MARK, CONTROL BOX (EXTERNAL-ALERT)(REGULATOR)	-	(1)	-	3116814 L1,P1,Q1,R1,V1,W1	
	87529-ZH9-W40	MARK, CONTROL BOX (ENGLISH) -	1	-	-	LHE4,QXE4,RHE4,SXE4	
			1	-	-	4537088 LHE4/A,QXE4/A,SXE4/A	
	87529-ZE2-010	PANEL, CONTROL BOX (INTERNAL)	-	(1)	-	W1/A	
			-	(1)	-	3116815 L1,P1,R1,V1,W1	
			-	(1)	-	4524995 L1/A,R1/A	
	87529-ZE2-811	MARK, CONTROL BOX (EXTERNAL)	1	(1)	-	ED3,LHE,L1,L1/A,P1,QAE2,QHE,Q1,Q1/A,RHE,R1,R1/A,SHE,SHEZ,SWE,V1,W1,W1/A	
			1	-	-	3116815 QAE,QXE,QXEB,SXE,SXEB,VXE,VXEB	
			1	-	-	4526638 QAE2/A,QXE/A,VXE/A,VXEB/A	
	87529-ZE2-860	MARK, CONTROL BOX (EXTERNAL-REGULATOR)	1	(1)	-	L1/A,PAE,R1/A,W1/A	
			-	(1)	-	3116815 L1,P1,Q1,R1,V1,W1	
			-	(1)	-	4533388 Q1/A	
	87529-ZH9-W41	MARK, CONTROL BOX (ENGLISH) -	1	-	-	4537089 LHE4/A,QXE4/A,SXE4/A	
	87529-ZE2-020	PANEL, CONTROL BOX (INTERNAL)	-	(1)	-	4524996 L1/A,R1/A	
	87529-ZE2-812	MARK, CONTROL BOX (EXP)	1	-	-	4526639 QAE2/A,QXE/A,VXE/A,VXEB/A	
	87529-ZE2-861	MARK, CONTROL BOX (EXTERNAL-REGULATOR)	-	(1)	-	4533389 Q1/A	



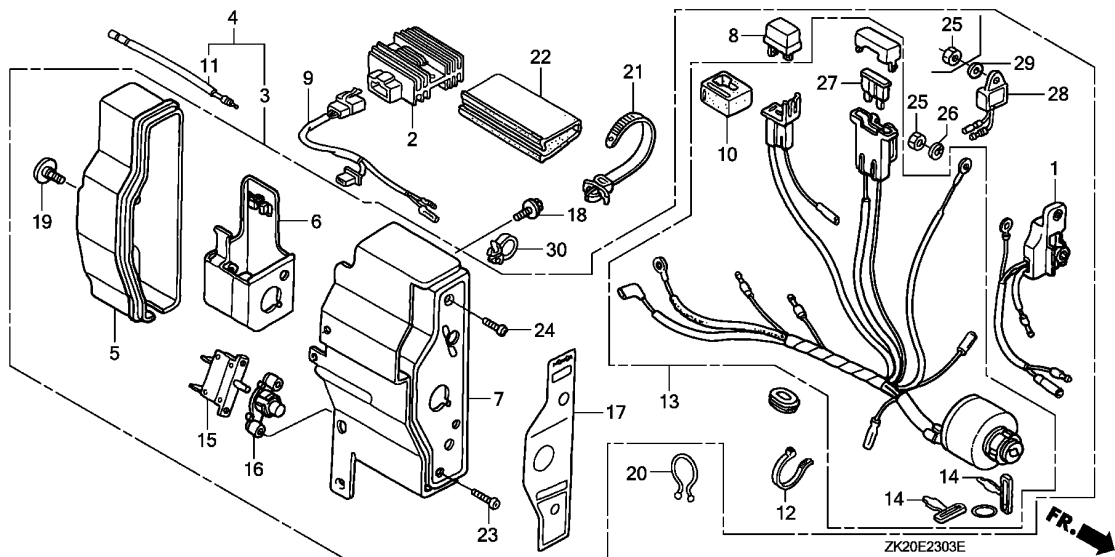

Ref. No.	Part No.	Description	Reqd. QTY			Serial No.	Parts catalogue code
			(1)	(2)	(3)		
18	90013-883-000	BOLT, FLANGE, 6X12(CT200) ...	2	(2)	-	-----	LHE4,LHE4/A,LKS,LKS/A,L1,L1/A,P1,QAE,QAE2,QAE2/A,QXE,QXE/A,QXEB,QXE4,QXE4/A,Q1,Q1/A,R1,R1/A,SXE,SXEB,SXE4,SXE4/A,VXE,VXE/A,VXEB,VXEB/A,V1,W1,W1/A
19	90380-MA6-010	SCREW, SPECIAL, 6X12	2	-	-	-----	3566749 PAE
20	90630-751-000	CLIP, PURSE LOCK	1	(1)	-	-----	ED3,LHE,LHE4,LHE4/A,L1,L1/A,PAE,P1,QAE,QAE2,QAE2/A,QHE,QXE,QXE/A,QXEB,QXE4,QXE4/A,Q1,Q1/A,RHE,RHE4,R1,R1/A,SHE,SHEZ,SWE,SXE,SXEB,SXE4,SXE4/A,VXE,VXE/A,VXEB,VXEB/A,V1,W1,W1/A
21	90672-SAO-003	STRAP, CABLE, 118MM(BLACK) ..	1	(1)	-	-----	ED3,LHE,LHE4,LHE4/A,LKS,LKS/A,L1,L1/A,PAE,P1,QAE,QAE2,QAE2/A,QHE,QXE,QXE/A,QXEB,QXE4,QXE4/A,Q1,Q1/A,RHE,RHE4,R1,R1/A,SHE,SHEZ,SWE,SXE,SXEB,SXE4,SXE4/A,VXE,VXE/A,VXEB,VXEB/A,V1,W1,W1/A
22	91406-ZE2-003	TUBE, FASTENER, 30MM	1	(1)	-	-----	ED3,LHE,LHE4,LHE4/A,LKS,LKS/A,L1,L1/A,PAE,P1,QAE,QAE2,QAE2/A,QHE,QXE,QXE/A,QXEB,QXE4,QXE4/A,Q1,Q1/A,RHE,RHE4,R1,R1/A,SHE,SHEZ,SWE,SXE,SXEB,SXE4,SXE4/A,VXE,VXE/A,VXEB,VXEB/A,V1,W1,W1/A
23	93500-03012-0H	SCREW, PAN, 3X12	2	(2)	-	-----	ED3,LHE,LHE4,LHE4/A,LKS,LKS/A,L1,L1/A,P1,QAE,QAE2,QAE2/A,QHE,QXE,QXE/A,QXEB,QXE4,QXE4/A,Q1,Q1/A,RHE,RHE4,R1,R1/A,SHE,SHEZ,SWE,SXE,SXEB,SXE4,SXE4/A,VXE,VXE/A,VXEB,VXEB/A,V1,W1,W1/A
24	93500-04012-0H	SCREW, PAN, 4X12	1	(1)	-	-----	ED3,LHE,LHE4,LHE4/A,L1,L1/A,PAE,P1,QAE,QAE2,QAE2/A,QHE,QXE,QXE/A,QXEB,QXE4,QXE4/A,Q1,Q1/A,RHE,RHE4,R1,R1/A,SHE,SHEZ,SWE,SXE,SXEB,SXE4,SXE4/A,VXE,VXE/A,VXEB,VXEB/A,V1,W1,W1/A
			1	-	-	-----	3320786 LKS

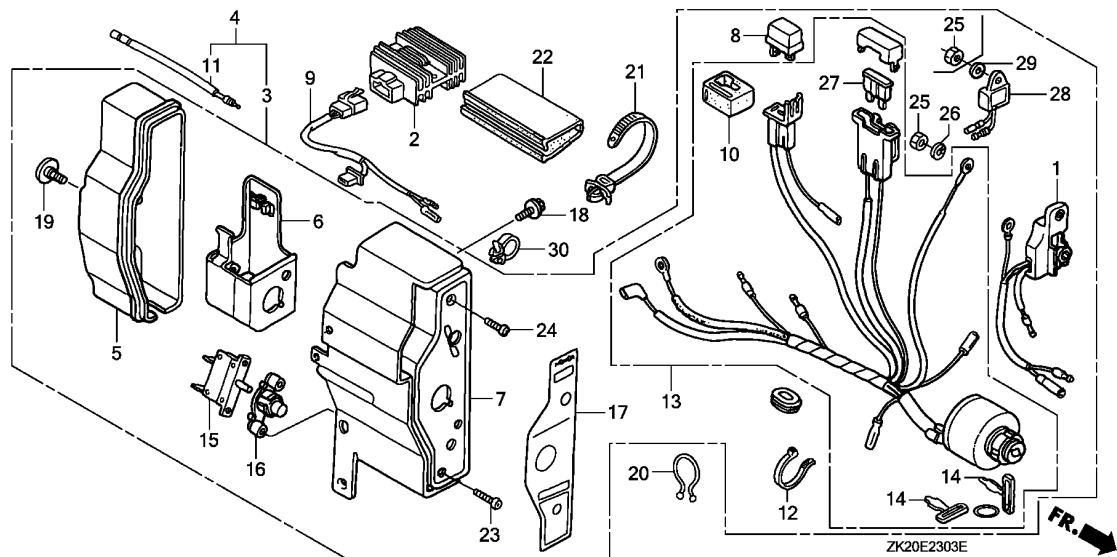

Ref. No.	Part No.	Description	Reqd. QTY			Serial No.	Parts catalogue code
			(1)	(2)	(3)		
25	94001-04390-0S	NUT, HEX., 4MM	1	(1)	-	3684578	L1,P1,QAE2,QXE,QXE4,Q1,R1,SXE4,VXE,VXEB,V1,W1
			1	-	-		ED3,LHE,LHE4,LHE4/A,PAE,QAE,QHE,QXEB,RHE,RHE4,SHE,SHEZ,SWE,SXE,SXEB
			1	-	-	3320786	LKS
			2	(2)	-		L1/A,QAE2/A,QXE/A,QXE4/A,Q1/A,R1/A,SXE4/A,VXE/A,VXEB/A,W1/A
			2	(2)	-	3684579	L1,P1,QAE2,QXE,QXE4,Q1,R1,SXE4,VXE,VXEB,V1,W1
26	94111-04800	WASHER, SPRING, 4MM	1	(1)	-		ED3,LHE,LHE4,LHE4/A,L1,L1/A,PAE,P1,QAE,QAE2,QAE2/A,QHE,QXE,QXE/A,QXEB,QXE4,QXE4/A,Q1,Q1/A,RHE,RHE4,R1,R1/A,SHE,SHEZ,SWE,SXE,SXEB,SXE4,SXE4/A,VXE,VXE/A,VXEB,VXEB/A,V1,W1,W1/A
			1	-	-	3320786	LKS
27	98200-30500	FUSE, BLADE (5A)	1	(1)	-		ED3,ETS,LHE,LHE4,LHE4/A,L1,L1/A,P1,QHE,QXE,QXE/A,QXEB,QXE4,QXE4/A,Q1,Q1/A,RHE,RHE4,R1,R1/A,SHE,SHEZ,SWE,SXE,SXEB,SXE4,SXE4/A,VXE/VXE/A,VXEB,VXEB/A,V1,W1,W1/A
	98200-31500	FUSE, BLADE (15A)	1	(1)	-		L1,L1/A,PAE,P1,QAE,QAE2,QAE2/A,Q1,Q1/A,R1,R1/A,V1,W1,W1/A
			1	-	-	3320786	LKS
28	34150-ZH7-003	ALERT UNIT, OIL	1	(1)	-		L1/A,QAE2/A,QXE4/A,R1/A,SXE4/A,VXEB/A
			1	(1)	-	3684579	L1,P1,QAE2,QXE,QXE4,Q1,R1,SXE4,VXE,VXEB,V1,W1
			1	(1)	-	4853039	QXE/A,Q1/A,VXE/A,W1/A
	34150-ZH7-013		1	(1)	-	4853040	QXE/A,Q1/A,VXE/A,W1/A
29	94101-04800	WASHER, PLAIN, 4MM	1	(1)	-		L1/A,QAE2/A,QXE/A,QXE4/A,Q1/A,R1/A,SXE4/A,VXE/A,VXEB/A,W1/A
			1	(1)	-	3684579	L1,P1,QAE2,QXE,QXE4,Q1,R1,SXE4,VXE,VXEB,V1,W1
30	36103-ZE1-000	HOLDER, STOP SWITCH CORD	1	-	-		PAE,QAE

E-23-20

REMOTE CONTROL BOX

2-D13

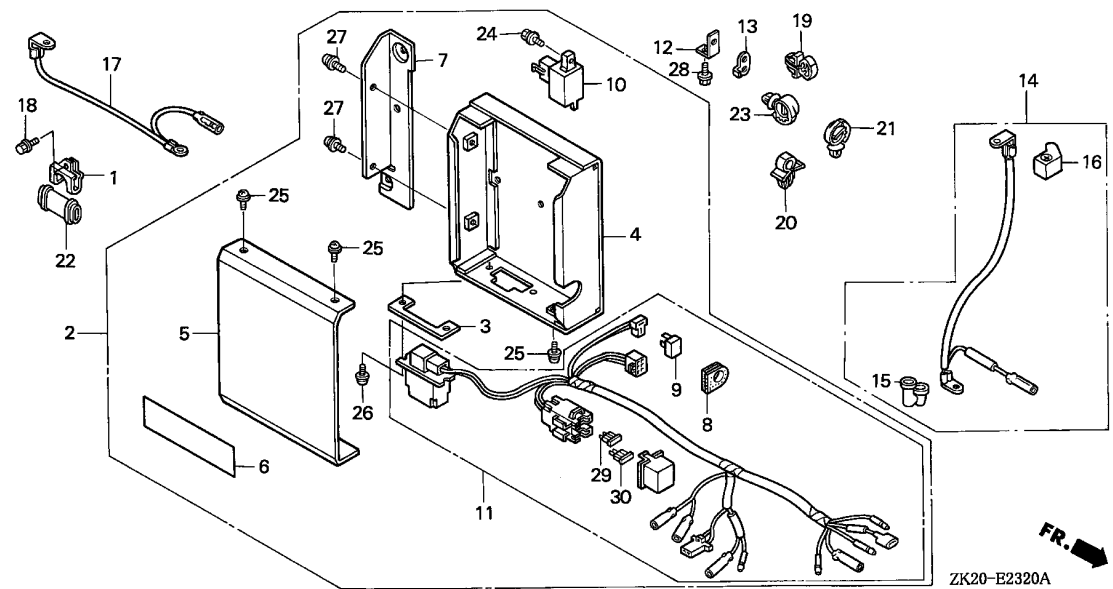

Ref. No.	L.O.N.	(Relative ref. Number) Description	F.R.T.
9	6131B8	RECTIFIER, SILICON	0.1
10	6131C8	DIODE, CONTROL	0.2
11	6111B9	HARNESS, CONTROL WIRE	0.4
14	610115	CABLE, BATTERY STARTER	0.1
17	6101A8	CABLE, BATTERY EARTH	0.1
29	8121A7	FUSE, BLADE	0.1

.NOTE: Same time for two units or more

Ref. No.	Part No.	Description	Reqd. QTY			Serial No.	Parts catalogue code
			(1)	(2)	(3)		
			GX240K1				
1	30561-ZB4-000	CLIP, WIRE	1	-	-	-----	WKA
2	31610-ZE2-V41	BOX ASSY., REMOTE CONTROL	1	-	-	-----	WKA
3	31613-880-810	PLATE, COUPLER SETTING	1	-	-	-----	WKA
4	31651-ZE2-V41	BOX COMP., REMOTE CONTROL	1	-	-	-----	WKA
5	31652-ZE2-V41	COVER, REMOTE CONTROL	1	-	-	-----	WKA
6	31654-ZE2-V41	MARK, REMOTE CONTROL	1	-	-	-----	WKA
7	31655-ZB4-000	BRACKET, RELAY BOX	1	-	-	-----	WKA
8	31658-899-000	GROMMET	1	-	-	-----	WKA
9	31700-124-003	RECTIFIER ASSY., SILICON (STANLEY)	1	-	-	-----	WKA
10	31710-ZB7-701	DIODE ASSY.	1	-	-	-----	WKA
11	32100-ZE2-V41	HARNESS ASSY., WIRE	1	-	-	-----	WKA
12	32105-759-000	BRACKET, WIRE HARNESS CLIP (H)	3	-	-	-----	WKA
13	32302-734-K50	STAY, CORD CLIP (B)	1	-	-	-----	WKA
14	32410-ZE2-V40	CABLE ASSY., STARTING	1	-	-	-----	WKA
15	32412-ZV4-811	COVER, MAGNETIC SWITCH TERMINAL	1	-	-	-----	WKA
16	32412-471-000	COVER, BATTERY TERMINAL	1	-	-	-----	WKA
17	32430-ZE2-V40	CABLE ASSY., EARTH	1	-	-	-----	WKA
18	90013-883-000	BOLT, FLANGE, 6X12(CT200)	1	-	-	-----	WKA
19	90655-SD3-013	CLIP, TRUNK & FUEL OPENER WIRE (BLACK)	3	-	-	-----	WKA
20	90681-752-003	CLIP, HARNESS	2	-	-	-----	WKA
21	90683-SA0-003	CLIP, WIRE HARNESS, 25MM	1	-	-	-----	WKA
22	91406-ZB4-000	TUBE, CORD	1	-	-	-----	WKA

2

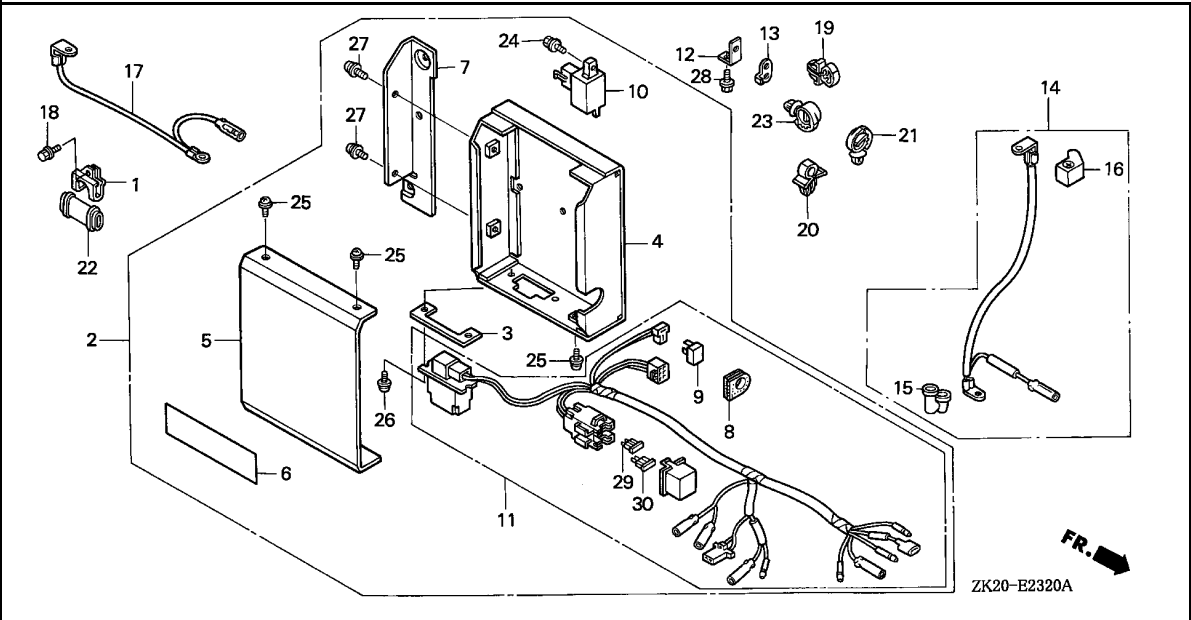

Ref. No.	Part No.	Description	Reqd. QTY			Serial No.	Parts catalogue code
			(1)	(2)	(3)		
			GX240K1				
23	91558-SD5-003	CLIP, WIRE HARNESS (BLACK) ..	2	-	-	-----	WKA
24	93403-04012-08	BOLT-WASHER, 4X12	1	-	-	-----	WKA
25	93891-04008-08	SCREW-WASHER, 4X8	3	-	-	-----	WKA
26	93892-03010-08	SCREW-WASHER, 3X10	2	-	-	-----	WKA
27	93893-05010-08	SCREW-WASHER, 5X10	2	-	-	-----	WKA
28	95701-06012-00	BOLT, FLANGE, 6X12	3	-	-	-----	WKA
29	98200-30500	FUSE, BLADE (5A)	1	-	-	-----	WKA
30	98200-31000	FUSE, BLADE (10A)	1	-	-	-----	WKA



E-23-21

AUTO THROTTLE

2-D15

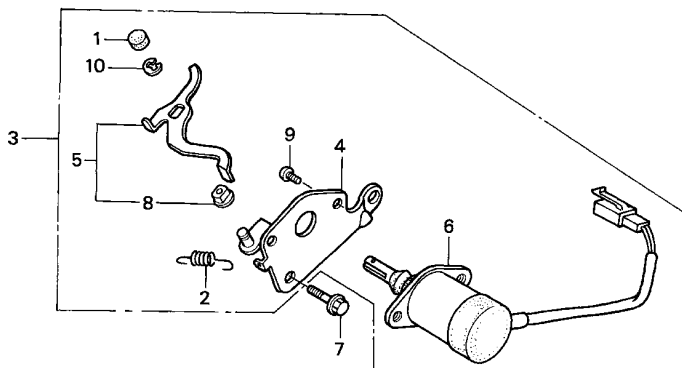

ZK20-E2321A

Ref. No.	L.O.N.	(Relative ref. Number) Description	F.R.T.
2	8101Q9	SPRING, CHOKE RETURN	0.2
3	8101S8	THROTTLE, AUTO	0.2
6	6211C5	SOLENOID, AUTO THROTTLE	0.3

2

Ref. No.	Part No.	Description	Reqd. QTY			Serial No.	Parts catalogue code
			GX240K1				
			(1)	(2)	(3)		
1	16252-ZA1-000	CAP, CHOKE LEVER	1	-	-	-----	EDN,EDS,EDS5
	16252-ZA1-010	1	-	-	3278944	EDS1
			1	-	-	3337057	EDN2,EDN2/A,EDS6,EDS6/A,EDT6,EDT6/A,ED2/A,EN2,EN2/A,VMT2
2	16268-893-000	SPRING, CHOKE RETURN	1	-	-	-----	ED2
			1	-	-	3337057	EDN,EDN2,EDN2/A,EDS,EDS5,EDS6,EDS6/A,EDT6,EDT6/A,ED2/A,EN2,EN2/A
			1	-	-	3337057	VMT2
			1	-	-	3278944	ED2
3	16270-ZB4-000	AUTO-THROTTLE ASSY.	1	-	-	-----	EDS1
	16270-ZB4-010	1	-	-	3278944	EDN,EDS,EDS5
			1	-	-	3278944	EDS1
			1	-	-	3337057	EDN2,EDN2/A,EDS6,EDS6/A,EDT6,EDT6/A,ED2/A,EN2,EN2/A,VMT2
4	16271-ZB4-000	STAY, SOLENOID THROTTLE	1	-	-	-----	ED2
			1	-	-	3337057	EDN,EDN2,EDN2/A,EDS,EDS5,EDS6,EDS6/A,EDT6,EDT6/A,ED2/A,EN2,EN2/A
			1	-	-	3337057	VMT2
			1	-	-	3278944	ED2
			1	-	-	3278944	EDS1
5	16273-ZB4-000	LEVER COMP., SOLENOID THROTTLE	1	-	-	-----	EDN,EDN2,EDN2/A,EDS,EDS5,EDS6,EDS6/A,EDT6,EDT6/A,ED2/A,EN2,EN2/A
			1	-	-	3337057	VMT2
			1	-	-	3337057	ED2
			1	-	-	3278944	EDS1
6	36160-ZB4-003	SOLENOID ASSY.	1	-	-	-----	EDN,EDN2,EDN2/A,EDS,EDS5,EDS6,EDS6/A,EDT6,EDT6/A,ED2/A,EN2,EN2/A
			1	-	-	3337057	VMT2
			1	-	-	3337057	ED2
			1	-	-	3278944	EDS1
7	90013-883-000	BOLT, FLANGE, 6X12(CT200) ...	1	-	-	-----	EDN,EDN2,EDN2/A,EDS,EDS5,EDS6,EDS6/A,EDT6,EDT6/A,ED2/A,EN2,EN2/A
			1	-	-	3337057	VMT2
			1	-	-	3337057	ED2
			1	-	-	3278944	EDS1

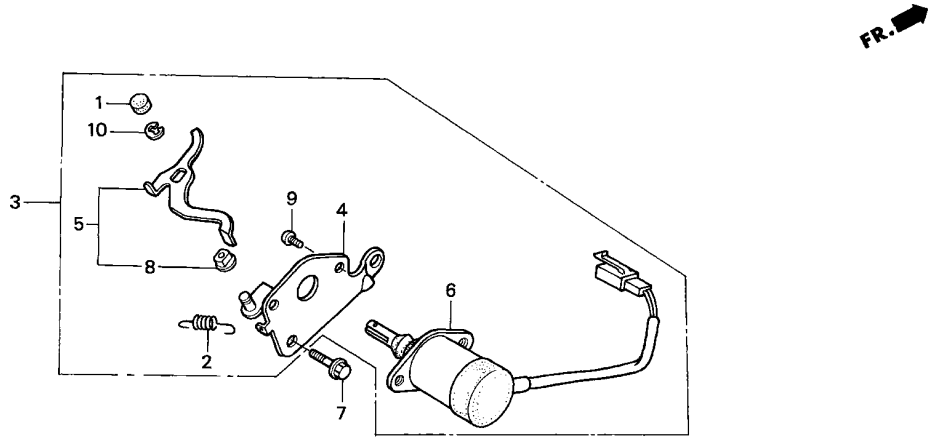

ZK20-E2321A

Ref. No.	Part No.	Description	Reqd. QTY			Serial No.	Parts catalogue code
			GX240K1				
			(1)	(2)	(3)		
8	91502-ZB4-701	BUSH, AUTO-THROTTLE LEVER ...	1	-	-	-----	EDN,EDN2,EDN2/A,EDS,EDS5,EDS6,EDS6/A,EDT6,EDT6/A,ED2/A,EN2,EN2/A VMT2
			1	-	-	3337057	----- ED2
			1	-	-	3278944	----- EDS1
9	93500-05008-0A	SCREW, PAN, 5X8	2	-	-	-----	EDN,EDN2,EDN2/A,EDS,EDS5,EDS6,EDS6/A,EDT6,EDT6/A,ED2/A,EN2,EN2/A VMT2
			2	-	-	3337057	----- ED2
			2	-	-	3278944	----- EDS1
10	94540-04018	E-RING, 4MM	1	-	-	-----	EDN,EDN2,EDN2/A,EDS,EDS5,EDS6,EDS6/A,EDT6,EDT6/A,ED2/A,EN2,EN2/A VMT2
			1	-	-	3337057	----- ED2
			1	-	-	3278944	----- EDS1



E-23-30

WIRE HARNESS

2-E 1

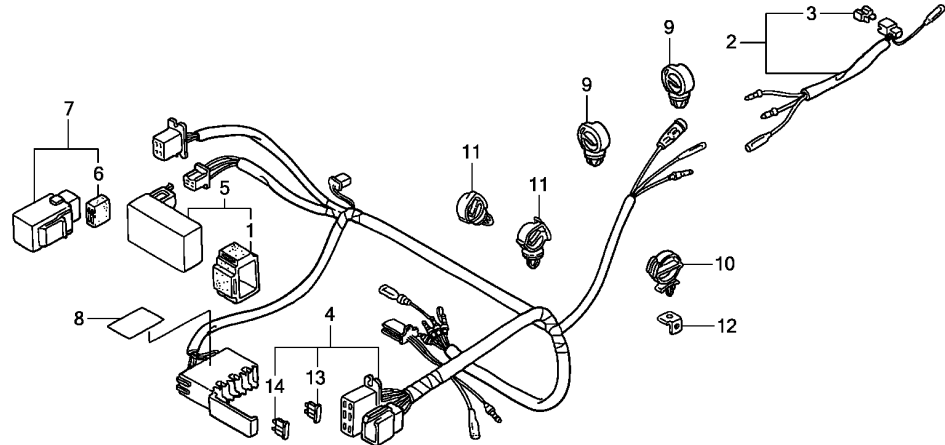

ZK20E2330B

Ref. No.	L.O.N.	(Relative ref. Number) Description	F.R.T.
3	6131B8	RECTIFIER, SILICON	0.1
4	6111D3	HARNESS, SUB WIRE	0.4
5	6211C7	CONTROL UNIT, SOLENOID	0.2
7	6151F6	TIMER UNIT	0.2
13		(14)	
	8121A7	FUSE, BLADE	0.1

.NOTE: Same time for two units or more

Ref. No.	Part No.	Description	Reqd. QTY			Serial No.	Parts catalogue code
			(1)	(2)	(3)		
			GX240K1				
1	30401-HA0-000	CUSHION, C.D.I. UNIT	1	-	-	-----	EDS5
2	31700-ZB7-003	DIODE ASSY., SOLENOID	1	-	-	-----	EDS5
3	31700-166-008	RECTIFIER COMP., SILICON	1	-	-	-----	EDS5
4	32100-ZB7-A00	HARNESS ASSY., SUB WIRE	1	-	-	3566259	EDS5
	32100-ZB7-A01	1	-	-	3566260	EDS5
5	36150-ZB7-A01	CONTROL UNIT, SOLENOID	1	-	-	-----	EDS5
6	38306-KK4-000	SUSPENSION, WINKER RELAY (MITSUBA)	1	-	-	-----	EDS5
7	39500-ZB7-003	TIMER UNIT	1	-	-	-----	EDS5
8	87117-ZB7-A30	LABEL, FUSE	1	-	-	-----	EDS5
9	90683-SA0-003	CLIP, WIRE HARNESS, 25MM	2	-	-	-----	EDS5
10	90690-SA0-003	STRAP, WIRE HARNESS, 25MM (BLACK)	1	-	-	-----	EDS5
11	90691-ZB7-003	CLIP, HARNESS	2	-	-	-----	EDS5
12	90700-ZB7-000	BASE, CORD CLIP	1	-	-	-----	EDS5
13	98200-30500	FUSE, BLADE (5A)	2	-	-	-----	EDS5
14	98200-31000	FUSE, BLADE (10A)	1	-	-	-----	EDS5

2

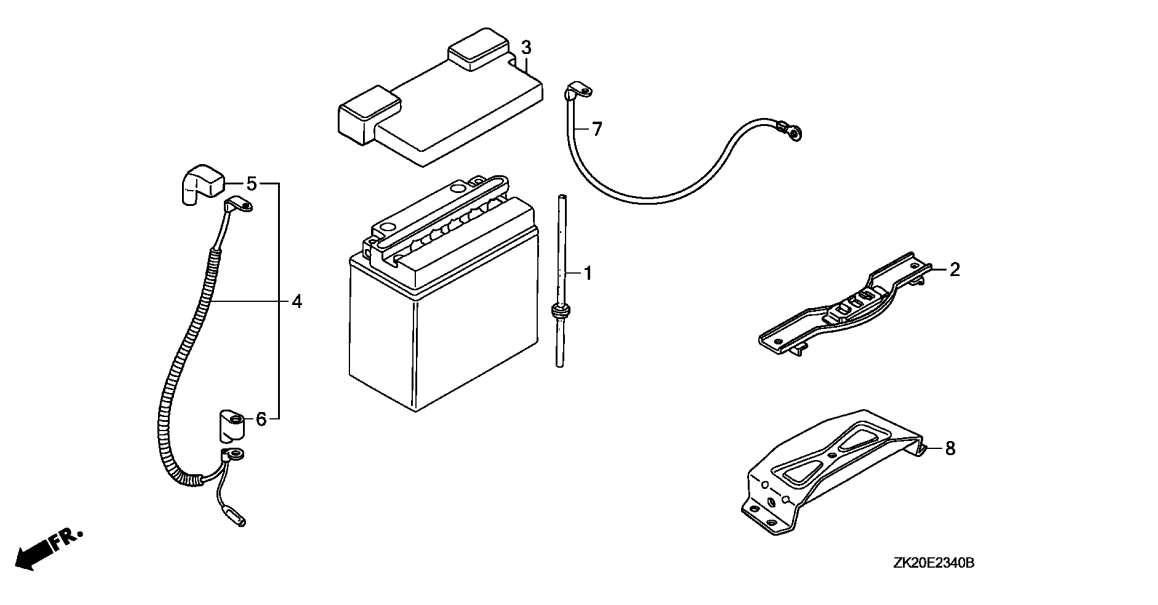

Ref. No.	L.O.N.	(Relative ref. Number) Description	F.R.T.
----------	--------	------------------------------------	--------

4	610115	CABLE, BATTERY STARTER	0.1
7	6101A8	CABLE, BATTERY EARTH	0.1

Ref. No.	Part No.	Description	Reqd. QTY			Serial No.	Parts catalogue code
			GX240K1				
			(1)	(2)	(3)		
1	31507-ZB7-000	TUBE, BATTERY BREATHER	1	-	-	-----	EDS5
2	31512-ZB7-000	PLATE, BATTERY SETTING	1	-	-	-----	EDS5
3	31513-ZB7-000	COVER, BATTERY	1	-	-	-----	EDS5
4	32410-ZB7-A00	CABLE ASSY., STARTING	1	-	-	-----	EDS5
5	32412-471-000	COVER, BATTERY TERMINAL	1	-	-	-----	EDS5
6	32416-460-000	COVER B, MAGNETIC SWITCH	1	-	-	-----	EDS5
7	32430-ZB7-000	CABLE ASSY., EARTH	1	-	-	-----	EDS5
8	50319-ZB7-000	BASE, BATTERY	1	-	-	-----	EDS5



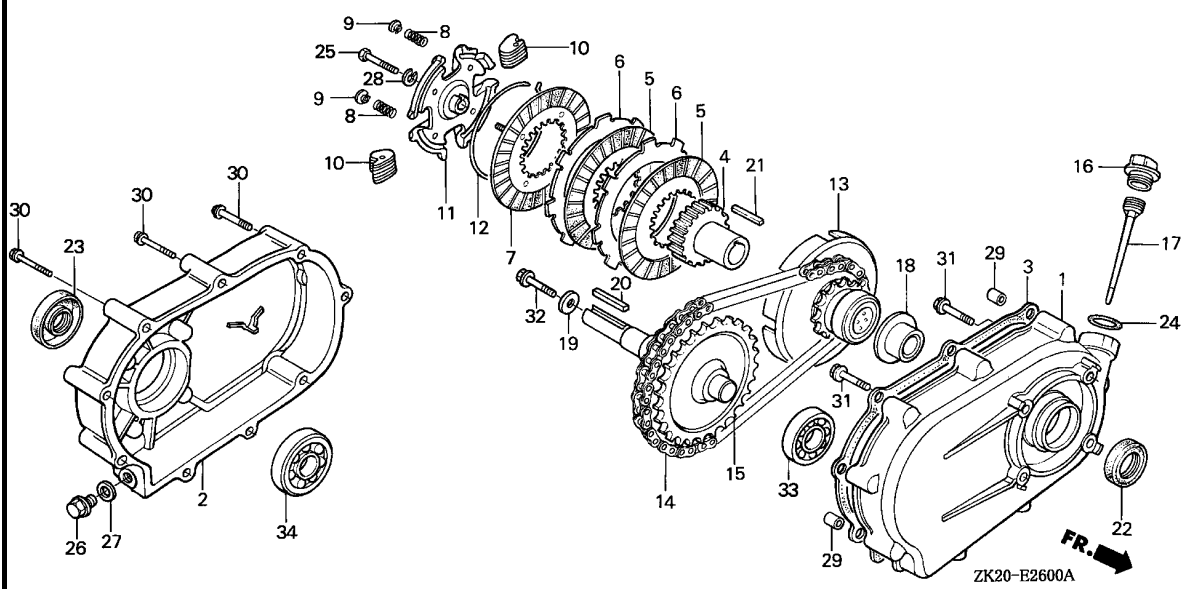

Ref. No.	L.O.N.	(Relative ref. Number) Description	F.R.T.
1	2141Y6	CASE, REDUCTION(R-TYPE)	0.4
2	2141W7	COVER, REDUCTION AND/OR PACKING, REDUCTION COVER (R-TYPE)	0.3
3	2141R2	PACKING, REDUCTION COVER	0.2
5	2141Z0	DISC, REDUCTION CLUTCH FRICTION	0.2
6	2141Z1	PLATE, REDUCTION CLUTCH	0.2
7	2141Z2	PLATE, REDUCTION CLUTCH PRESSURE	0.2
11	2121F5	(10) HOLDER, CLUTCH WEIGHT	0.2
14	2141W3	(13) CHAIN, POWER TAKE OFF DRIVE (R-TYPE)	0.3
15	2141H4	SHAFT, POWER TAKE OFF	0.3
22	2141AB	OIL SEAL, REDUCTION CASE	0.3
23	2141X4	OIL SEAL, POWER TAKE OFF SHAFT (R-TYPE) :REAR	0.2
33	2141Y5	BEARING, POWER TAKE OFF SHAFT (R-TYPE) :FRONT	0.4
34	2141X9	BEARING, POWER TAKE OFF SHAFT (R-TYPE) :REAR	0.3

Ref. No.	Part No.	Description	Reqd. QTY			Serial No.	Parts catalogue code
			(1)	(2)	(3)		
1	21510-889-750	CASE, REDUCTION	1	1	-	RA,RA2,RA2/A,RD,RD/A,RH,RHE,RHE4,RHQ4,RHQ4/A,RJ,RJ/A,RSC2,RSS1	
2	21610-889-750	COVER, REDUCTION	1	1	-	RSS1/A,RTB2,RTB2/A,RX,RX/A,RXQ4,RXQ4/A,R1,R1/A	
3	21691-889-750	PACKING, REDUCTION COVER	1	1	-	RA,RA2,RA2/A,RD,RD/A,RH,RHE,RHE4,RHQ4,RHQ4/A,RJ,RJ/A,RSC2,RSS1	
4	22121-889-750	CENTER, CLUTCH	1	1	-	RSS1/A,RTB2,RTB2/A,RX,RX/A,RXQ4,RXQ4/A,R1,R1/A	
5	22201-822-610	DISK, CLUTCH FRICTION	2	2	-	RA,RA2,RA2/A,RD,RD/A,RH,RHE,RHE4,RHQ4,RHQ4/A,RJ,RJ/A,RSC2,RSS1	
6	22311-822-610	PLATE, CLUTCH	2	2	-	RSS1/A,RTB2,RTB2/A,RX,RX/A,RXQ4,RXQ4/A,R1,R1/A	
7	22350-822-610	PLATE COMP., CLUTCH PRESSURE	1	1	-	RA,RA2,RA2/A,RD,RD/A,RH,RHE,RHE4,RHQ4,RHQ4/A,RJ,RJ/A,RSC2,RSS1	
8	22411-822-611	SPRING, CLUTCH FREE	4	4	-	RSS1/A,RTB2,RTB2/A,RX,RX/A,RXQ4,RXQ4/A,R1,R1/A	
9	22421-822-610	HOLDER, CLUTCH SPRING	4	4	-	RA,RA2,RA2/A,RD,RD/A,RH,RHE,RHE4,RHQ4,RHQ4/A,RJ,RJ/A,RSC2,RSS1	
10	22521-822-610	WEIGHT, CLUTCH	48	48	-	RSS1/A,RTB2,RTB2/A,RX,RX/A,RXQ4,RXQ4/A,R1,R1/A	
11	22531-889-750	HOLDER, CLUTCH WEIGHT	1	1	-	RA,RA2,RA2/A,RD,RD/A,RH,RHE,RHE4,RHQ4,RHQ4/A,RJ,RJ/A,RSC2,RSS1	
12	22535-822-610	CENTER, CLUTCH WEIGHT	1	1	-	RSS1/A,RTB2,RTB2/A,RX,RX/A,RXQ4,RXQ4/A,R1,R1/A	
13	23120-889-750	SPROCKET COMP., DRIVE (14T)	1	1	-	RA,RA2,RA2/A,RD,RD/A,RH,RHE,RHE4,RHQ4,RHQ4/A,RJ,RJ/A,RSC2,RSS1	
						RSS1/A,RTB2,RTB2/A,RX,RX/A,RXQ4,RXQ4/A,R1,R1/A	

Ref. No.	Part No.	Description	Reqd. QTY			Serial No.	Parts catalogue code
			(1)	(2)	(3)		
14	23161-822-611	CHAIN, DRIVE (RK428SH-36LE) -	1	1	-	RA, RA2, RA2/A, RD, RD/A, RH, RHE, RHE4, RHQ4, RHQ4/A, RJ, RJ/A, RSC2, RSS1	
15	23711-822-610	SHAFT COMP., P.T.O. (28T) ---	1	1	-	RSS1/A, RTB2, RTB2/A, RX, RX/A, RXQ4, RXQ4/A, R1, R1/A RA, RA2, RA2/A, RD, RD/A, RH, RHE, RHE4, RHQ4, RHQ4/A, RJ, RJ/A, RSC2, RSS1 RSS1/A, RTB2, RTB2/A, RX, RX/A, RXQ4, RXQ4/A, R1, R1/A	
16	25620-823-000	CAP, REDUCTION OIL (YELLOW) -	1	1	-	RA, RA2, RA2/A, RD, RD/A, RH, RHE, RHE4, RHQ4, RHQ4/A, RJ, RJ/A, RSC2, RSS1	
	25620-805-612	CAP, REDUCTION OIL (GRAY) ---	1	1	-	RSS1/A, RTB2, RTB2/A, RX, RX/A, RXQ4, RXQ4/A, R1, R1/A RA2/A, RD/A, RHQ4/A, RJ/A, RSS1/A, RTB2/A, RX/A, RXQ4/A, R1/A	
17	25651-889-750	GAUGE, OIL LEVEL	1	1	-	RA, RA2, RA2/A, RD, RD/A, RH, RHE, RHE4, RHQ4, RHQ4/A, RJ, RJ/A, RSC2, RSS1	
18	90403-889-000	WASHER, THRUST, 25MM	1	1	-	RSS1/A, RTB2, RTB2/A, RX, RX/A, RXQ4, RXQ4/A, R1, R1/A RA, RA2, RA2/A, RD, RD/A, RH, RHE, RHE4, RHQ4, RHQ4/A, RJ, RJ/A, RSC2, RSS1	
19	90534-706-010	WASHER, LOCK, 8MM	1	(1)	-	RSS1/A, RTB2, RTB2/A, RX, RX/A, RXQ4, RXQ4/A, R1, R1/A RJ, RJ/A, RSS1, RSS1/A, R1, R1/A	
20	90741-805-000	KEY, 7X7X33	1	(1)	-	RA, RA2, RA2/A, RD, RD/A, RH, RHE, RHE4, RHQ4, RHQ4/A, RJ, RJ/A, RSC2, RSS1	
	90741-889-810	KEY, 7X7X33 (YELLOW)	(1)	(1)	-	RSS1/A, RTB2, RTB2/A, RX, RX/A, RXQ4, RXQ4/A, R1, R1/A RA, RA2, RA2/A, RD, RD/A, RH, RHE, RHE4, RHQ4, RHQ4/A, RJ, RJ/A, RSC2, RSS1 RSS1/A, RTB2, RTB2/A, RX, RX/A, RXQ4, RXQ4/A, R1, R1/A	
21	90741-889-000	KEY, CLUTCH CENTER	1	1	-	RA, RA2, RA2/A, RD, RD/A, RH, RHE, RHE4, RHQ4, RHQ4/A, RJ, RJ/A, RSC2, RSS1	
22	91201-890-003	OIL SEAL, 30X46X8	1	1	-	RSS1/A, RTB2, RTB2/A, RX, RX/A, RXQ4, RXQ4/A, R1, R1/A RA, RA2, RA2/A, RD, RD/A, RH, RHE, RHE4, RHQ4, RHQ4/A, RJ, RJ/A, RSC2, RSS1	
23	91202-805-610	OIL SEAL (PJ30507)	1	1	-	RSS1/A, RTB2, RTB2/A, RX, RX/A, RXQ4, RXQ4/A, R1, R1/A RA, RA2, RA2/A, RD, RH, RHE, RHE4, RHQ4, RHQ4/A, RJ, RSC2, RSS1, RTB2, RTB2/A RX, RXQ4, RXQ4/A, R1	
	91202-22F-801	OIL SEAL, 30X50X7	1	1	-	4827849 RD/A, RJ/A, RSS1/A, RX/A, R1/A	
24	91301-805-000	O-RING, 26X2.7	1	1	-	4827850 RD/A, RJ/A, RSS1/A, RX/A, R1/A RA, RA2, RA2/A, RD, RD/A, RH, RHE, RHE4, RHQ4, RHQ4/A, RJ, RJ/A, RSC2, RSS1	
25	92101-08035-OH	BOLT, HEX., 8X35	1	1	-	RSS1/A, RTB2, RTB2/A, RX, RX/A, RXQ4, RXQ4/A, R1, R1/A RA, RA2, RD, RH, RHE, RHE4, RHQ4, RJ, RSC2, RSS1, RTB2, RX, RXQ4, R1	
	92101-08035-OA	1	1	-	RA2/A, RD/A, RHQ4/A, RJ/A, RSS1/A, RTB2/A, RX/A, RXQ4/A, R1/A	
26	92800-12000	BOLT, DRAIN PLUG, 12MM	1	1	-	RA, RA2, RA2/A, RD, RD/A, RH, RHE, RHE4, RHQ4, RHQ4/A, RJ, RJ/A, RSC2, RSS1	
27	94109-12000	WASHER, DRAIN PLUG, 12MM	1	1	-	RSS1/A, RTB2, RTB2/A, RX, RX/A, RXQ4, RXQ4/A, R1, R1/A RA, RA2, RA2/A, RD, RD/A, RH, RHE, RHE4, RHQ4, RHQ4/A, RJ, RJ/A, RSC2, RSS1	
28	94111-08800	WASHER, SPRING, 8MM	1	1	-	RSS1/A, RTB2, RTB2/A, RX, RX/A, RXQ4, RXQ4/A, R1, R1/A RA, RA2, RA2/A, RD, RD/A, RH, RHE, RHE4, RHQ4, RHQ4/A, RJ, RJ/A, RSC2, RSS1	
29	94301-08140	DOWEL PIN, 8X14	2	2	-	RSS1/A, RTB2, RTB2/A, RX, RX/A, RXQ4, RXQ4/A, R1, R1/A RA, RA2, RA2/A, RD, RD/A, RH, RHE, RHE4, RHQ4, RHQ4/A, RJ, RJ/A, RSC2, RSS1	
30	95701-06050-08	BOLT, FLANGE, 6X50	9	9	-	RSS1/A, RTB2, RTB2/A, RX, RX/A, RXQ4, RXQ4/A, R1, R1/A RA, RA2, RA2/A, RD, RD/A, RH, RHE, RHE4, RHQ4, RHQ4/A, RJ, RJ/A, RSC2, RSS1	
31	95701-08032-08	BOLT, FLANGE, 8X32	4	4	-	RSS1/A, RTB2, RTB2/A, RX, RX/A, RXQ4, RXQ4/A, R1, R1/A RA, RA2, RA2/A, RD, RD/A, RH, RHE, RHE4, RHQ4, RHQ4/A, RJ, RJ/A, RSC2, RSS1	
32	95900-08025-00	BOLT, FLANGE, 8X25	1	1	-	RA, RD, RH, RHE, RJ, RX, R1	
	92101-08025-OA	BOLT, HEX., 8X25	1	(1)	-	RJ, RJ/A, RSS1, RSS1/A, R1, R1/A	
33	96100-62050-00	BEARING, RADIAL BALL, 6205 ..	1	1	-	RA, RA2, RA2/A, RD, RD/A, RH, RHE, RHE4, RHQ4, RHQ4/A, RJ, RJ/A, RSC2, RSS1	
34	96100-62060-00	BEARING, RADIAL BALL, 6206 ..	1	1	-	RSS1/A, RTB2, RTB2/A, RX, RX/A, RXQ4, RXQ4/A, R1, R1/A RA, RA2, RA2/A, RD, RD/A, RH, RHE, RHE4, RHQ4, RHQ4/A, RJ, RJ/A, RSC2, RSS1 RSS1/A, RTB2, RTB2/A, RX, RX/A, RXQ4, RXQ4/A, R1, R1/A	



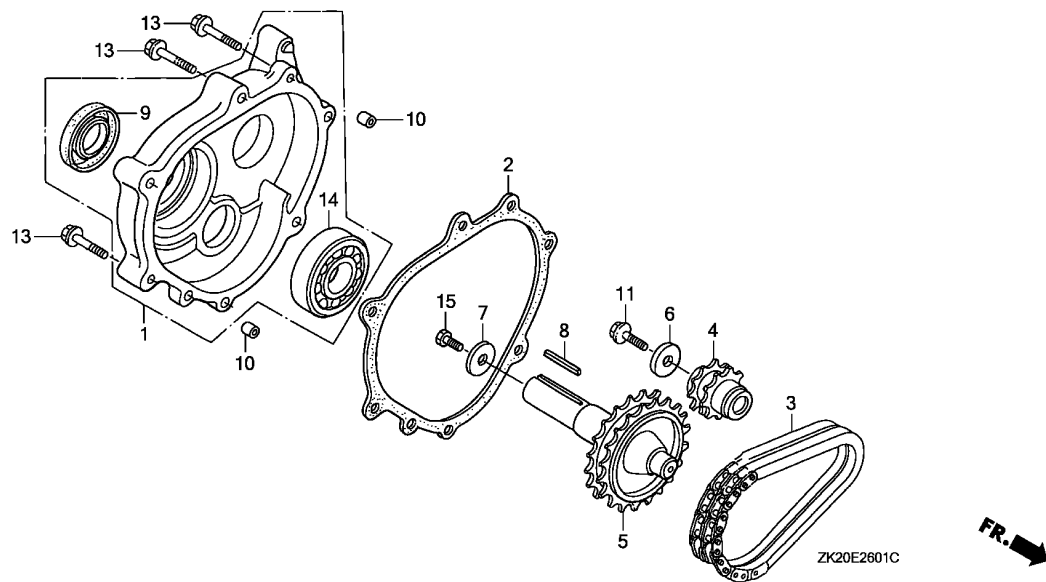

Ref. No.	L.O.N.	(Relative ref. Number) Description	F.R.T.
1	(2)		
2141W9		COVER, CHAIN CASE AND/OR PACKING, CHAIN CASE COVER (L-TYPE)	0.2
3	2141W2	CHAIN, POWER TAKE OFF DRIVE (L-TYPE)	0.2
4	2141X0	SPROCKET, POWER TAKE OFF DRIVE CHAIN(L-TYPE)	0.2
5	2141V7	SHAFT, POWER TAKE OFF(L-TYPE)	0.2
9	2141X3	OIL SEAL, POWER TAKE OFF SHAFT (L-TYPE) :REAR	0.2
14	2141X8	BEARING, POWER TAKE OFF SHAFT (L-TYPE) :REAR	0.3

Ref. No.	Part No.	Description	Reqd. QTY			Serial No.	Parts catalogue code
			(1)	(2)	(3)		
1	11500-ZE2-610	COVER ASSY., CHAIN CASE	1	1	-	LD,LDB1,LDB3,LH,LH/A,LHE,LHE4,LHE4/A,LHZ,LJ,LJ/A,LJG,LJG/A,LJG1 LJS,LJS/A,LK,LKS,LKS/A,LM9,LNJ,LNZ,LP,LP/A,LSS4,LSS5,LSS5/A,LSX LSX/A,LW,LX,LX/A,LXF,LXQ4,LXQ4/A,LXZ,LX2,LX2/A,L1,L1/A LT,LT/A	
2	11500-ZK2-800 11521-ZE2-800	PACKING, CHAIN CASE COVER ...	1	(1)	-	LD,LDB1,LDB3,LH,LH/A,LHE,LHE4,LHE4/A,LHZ,LJ,LJ/A,LJG,LJG/A,LJG1 LJS,LJS/A,LK,LKS,LKS/A,LM9,LNJ,LNZ,LP,LP/A,LSS4,LSS5,LSS5/A,LSX LSX/A,LT,LT/A,LW,LX,LX/A,LXF,LXQ4,LXQ4/A,LXZ,LX2,LX2/A,L1,L1/A LD,LDB1,LDB3,LH,LH/A,LHE,LHE4,LHE4/A,LHZ,LJ,LJ/A,LJG,LJG/A,LJG1 LJS,LJS/A,LK,LKS,LKS/A,LM9,LNJ,LNZ,LP,LP/A,LSS4,LSS5,LSS5/A,LSX LSX/A,LT,LT/A,LW,LX,LX/A,LXF,LXQ4,LXQ4/A,LXZ,LX2,LX2/A,L1,L1/A LD,LDB1,LDB3,LH,LH/A,LHE,LHE4,LHE4/A,LHZ,LJ,LJ/A,LJG,LJG/A,LJG1 LJS,LJS/A,LK,LKS,LKS/A,LM9,LNJ,LNZ,LP,LP/A,LSS4,LSS5,LSS5/A,LSX LSX/A,LW,LX,LX/A,LXF,LXQ4,LXQ4/A,LXZ,LX2,LX2/A,L1,L1/A LT,LT/A	
3	14411-ZE2-611	CHAIN, P.T.O. DRIVE	1	1	-	LD,LDB1,LDB3,LH,LH/A,LHE,LHE4,LHE4/A,LHZ,LJ,LJ/A,LJG,LJG/A,LJG1 LJS,LJS/A,LK,LKS,LKS/A,LM9,LNJ,LNZ,LP,LP/A,LSS4,LSS5,LSS5/A,LSX LSX/A,LT,LT/A,LW,LX,LX/A,LXF,LXQ4,LXQ4/A,LXZ,LX2,LX2/A,L1,L1/A LD,LDB1,LDB3,LH,LH/A,LHE,LHE4,LHE4/A,LHZ,LJ,LJ/A,LJG,LJG/A,LJG1 LJS,LJS/A,LK,LKS,LKS/A,LM9,LNJ,LNZ,LP,LP/A,LSS4,LSS5,LSS5/A,LSX LSX/A,LT,LT/A,LW,LX,LX/A,LXF,LXQ4,LXQ4/A,LXZ,LX2,LX2/A,L1,L1/A LD,LDB1,LDB3,LH,LH/A,LHE,LHE4,LHE4/A,LHZ,LJ,LJ/A,LJG,LJG/A,LJG1 LJS,LJS/A,LK,LKS,LKS/A,LM9,LNJ,LNZ,LP,LP/A,LSS4,LSS5,LSS5/A,LSX LSX/A,LW,LX,LX/A,LXF,LXQ4,LXQ4/A,LXZ,LX2,LX2/A,L1,L1/A LT,LT/A	
4	23110-ZE2-610	SPROCKET, DRIVE (14T)	1	1	-	LD,LDB1,LDB3,LH,LH/A,LHE,LHE4,LHE4/A,LHZ,LJ,LJ/A,LJG,LJG/A,LJG1 LJS,LJS/A,LK,LKS,LKS/A,LM9,LNJ,LNZ,LP,LP/A,LSS4,LSS5,LSS5/A,LSX LSX/A,LT,LT/A,LW,LX,LX/A,LXF,LXQ4,LXQ4/A,LXZ,LX2,LX2/A,L1,L1/A LD,LDB1,LDB3,LH,LH/A,LHE,LHE4,LHE4/A,LHZ,LJ,LJ/A,LJG,LJG/A,LJG1 LJS,LJS/A,LK,LKS,LKS/A,LM9,LNJ,LNZ,LP,LP/A,LSS4,LSS5,LSS5/A,LSX LSX/A,LT,LT/A,LW,LX,LX/A,LXF,LXQ4,LXQ4/A,LXZ,LX2,LX2/A,L1,L1/A LD,LDB1,LDB3,LH,LH/A,LHE,LHE4,LHE4/A,LHZ,LJ,LJ/A,LJG,LJG/A,LJG1 LJS,LJS/A,LK,LKS,LKS/A,LM9,LNJ,LNZ,LP,LP/A,LSS4,LSS5,LSS5/A,LSX LSX/A,LW,LX,LX/A,LXF,LXQ4,LXQ4/A,LXZ,LX2,LX2/A,L1,L1/A LT,LT/A	
5	23710-ZE2-610 23710-ZK2-800	SHAFT, P.T.O. (28T)	1	1	-	LD,LDB1,LDB3,LH,LH/A,LHE,LHE4,LHE4/A,LHZ,LJ,LJ/A,LJG,LJG/A,LJG1 LJS,LJS/A,LK,LKS,LKS/A,LM9,LNJ,LNZ,LP,LP/A,LSS4,LSS5,LSS5/A,LSX LSX/A,LW,LX,LX/A,LXF,LXQ4,LXQ4/A,LXZ,LX2,LX2/A,L1,L1/A LD,LDB1,LDB3,LH,LH/A,LHE,LHE4,LHE4/A,LHZ,LJ,LJ/A,LJG,LJG/A,LJG1 LJS,LJS/A,LK,LKS,LKS/A,LM9,LNJ,LNZ,LP,LP/A,LSS4,LSS5,LSS5/A,LSX LSX/A,LT,LT/A,LW,LX,LX/A,LXF,LXQ4,LXQ4/A,LXZ,LX2,LX2/A,L1,L1/A LD,LDB1,LDB3,LH,LH/A,LHE,LHE4,LHE4/A,LHZ,LJ,LJ/A,LJG,LJG/A,LJG1 LJS,LJS/A,LK,LKS,LKS/A,LM9,LNJ,LNZ,LP,LP/A,LSS4,LSS5,LSS5/A,LSX LSX/A,LW,LX,LX/A,LXF,LXQ4,LXQ4/A,LXZ,LX2,LX2/A,L1,L1/A LT,LT/A	
6	90473-842-000	WASHER, 8MM	1	1	-	LD,LDB1,LDB3,LH,LH/A,LHE,LHE4,LHE4/A,LHZ,LJ,LJ/A,LJG,LJG/A,LJG1 LJS,LJS/A,LK,LKS,LKS/A,LM9,LNJ,LNZ,LP,LP/A,LSS4,LSS5,LSS5/A,LSX LSX/A,LT,LT/A,LW,LX,LX/A,LXF,LXQ4,LXQ4/A,LXZ,LX2,LX2/A,L1,L1/A LD,LDB1,LDB3,LH,LH/A,LHE,LHE4,LHE4/A,LHZ,LJ,LJ/A,LJG,LJG/A,LJG1 LJS,LJS/A,LK,LKS,LKS/A,LM9,LNJ,LNZ,LP,LP/A,LSS4,LSS5,LSS5/A,LSX LSX/A,LT,LT/A,LW,LX,LX/A,LXF,LXQ4,LXQ4/A,LXZ,LX2,LX2/A,L1,L1/A LD,LDB1,LDB3,LH,LH/A,LHE,LHE4,LHE4/A,LHZ,LJ,LJ/A,LJG,LJG/A,LJG1 LJS,LJS/A,LK,LKS,LKS/A,LM9,LNJ,LNZ,LP,LP/A,LSS4,LSS5,LSS5/A,LSX LSX/A,LW,LX,LX/A,LXF,LXQ4,LXQ4/A,LXZ,LX2,LX2/A,L1,L1/A LT,LT/A	
7	90471-ZE3-000 90534-706-010	WASHER, 10.5X40X4	1	-	-	LJ,LJ/A,LJG,LJG/A,LJG1,LJS,LJS/A,LK,LM9,LNJ,LNZ,LSS4,LSS5,LSS5/A L1,L1/A	
8	90741-805-000	KEY, 7X7X33	1	(1)	-	LD,LDB1,LDB3,LH,LH/A,LHE,LHE4,LHE4/A,LHZ,LJ,LJ/A,LJG,LJG/A,LJG1 LJS,LJS/A,LK,LKS,LKS/A,LM9,LNJ,LNZ,LP,LP/A,LSS4,LSS5,LSS5/A,LSX LSX/A,LW,LX,LX/A,LXF,LXQ4,LXQ4/A,LXZ,LX2,LX2/A,L1,L1/A	

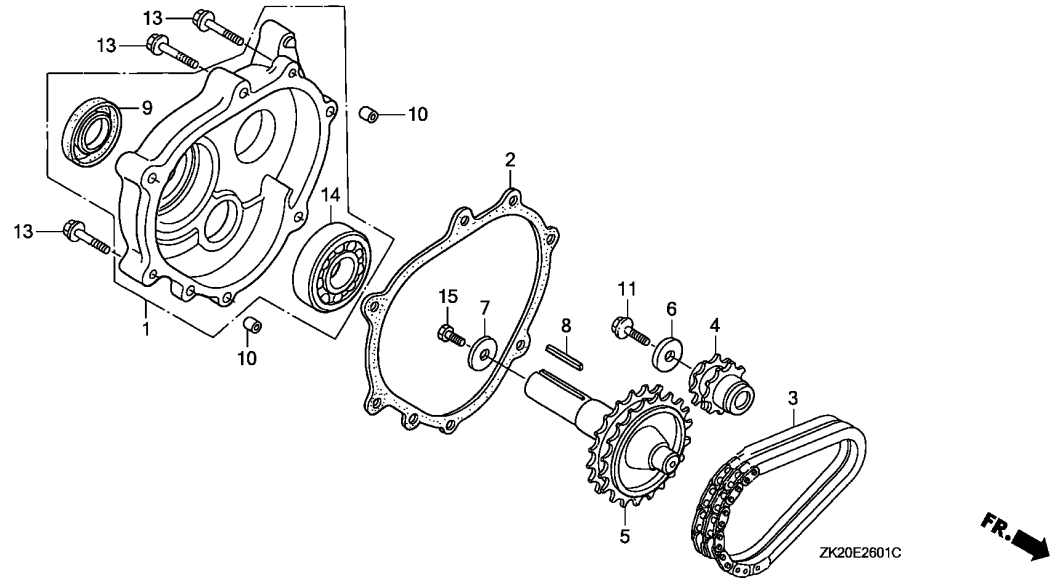

Ref. No.	Part No.	Description	Reqd. QTY			Serial No.	Parts catalogue code
			(1)	(2)	(3)		
(8)	90741-889-810	KEY, 7X7X33(YELLOW)	(1)	(1)	-	-----	LD,LDB1,LDB3,LH,LH/A,LHE,LHE4,LHE4/A,LHZ,LJ,LJ/A,LJG,LJG/A,LJG1 LJS,LJS/A,LK,LKS,LKS/A,LM9,LNJ,LNZ,LP,LP/A,LSS4,LSS5,LSS5/A,LSX LSX/A,LW,LX,LX/A,LXF,LXQ4,LXQ4/A,LXZ,LX2,LX2/A,L1,L1/A
	90745-ZK2-800	KEY, 6.3X6.3X33	1	-	-	-----	LT,LT/A
9	91201-890-003	OIL SEAL, 30X46X8	1	1	-	-----	LD,LDB1,LDB3,LH,LH/A,LHE,LHE4,LHE4/A,LHZ,LJ,LJ/A,LJG,LJG/A,LJG1 LJS,LJS/A,LK,LKS,LKS/A,LM9,LNJ,LNZ,LP,LP/A,LSS4,LSS5,LSS5/A,LSX LSX/A,LT,LT/A,LW,LX,LX/A,LXF,LXQ4,LXQ4/A,LXZ,LX2,LX2/A,L1,L1/A
10	94301-08140	DOWEL PIN, 8X14	2	2	-	-----	LD,LDB1,LDB3,LH,LH/A,LHE,LHE4,LHE4/A,LHZ,LJ,LJ/A,LJG,LJG/A,LJG1 LJS,LJS/A,LK,LKS,LKS/A,LM9,LNJ,LNZ,LP,LP/A,LSS4,LSS5,LSS5/A,LSX LSX/A,LT,LT/A,LW,LX,LX/A,LXF,LXQ4,LXQ4/A,LXZ,LX2,LX2/A,L1,L1/A
11	95701-08025-00	BOLT, FLANGE, 8X25	1	1	-	-----	LD,LDB1,LDB3,LH,LH/A,LHE,LHE4,LHE4/A,LHZ,LJ,LJ/A,LJG,LJG/A,LJG1 LJS,LJS/A,LK,LKS,LKS/A,LM9,LNJ,LNZ,LP,LP/A,LSS4,LSS5,LSS5/A,LSX LSX/A,LT,LT/A,LW,LX,LX/A,LXF,LXQ4,LXQ4/A,LXZ,LX2,LX2/A,L1,L1/A
13	95701-08040-00	BOLT, FLANGE, 8X40	6	6	-	-----	LD,LDB1,LDB3,LH,LH/A,LHE,LHE4,LHE4/A,LHZ,LJ,LJ/A,LJG,LJG/A,LJG1 LJS,LJS/A,LK,LKS,LKS/A,LM9,LNJ,LNZ,LP,LP/A,LSS4,LSS5,LSS5/A,LSX LSX/A,LT,LT/A,LW,LX,LX/A,LXF,LXQ4,LXQ4/A,LXZ,LX2,LX2/A,L1,L1/A
14	96100-62060-00	BEARING, RADIAL BALL, 6206	1	1	-	-----	LD,LDB1,LDB3,LH,LH/A,LHE,LHE4,LHE4/A,LHZ,LJ,LJ/A,LJG,LJG/A,LJG1 LJS,LJS/A,LK,LKS,LKS/A,LM9,LNJ,LNZ,LP,LP/A,LSS4,LSS5,LSS5/A,LSX LSX/A,LT,LT/A,LW,LX,LX/A,LXF,LXQ4,LXQ4/A,LXZ,LX2,LX2/A,L1,L1/A
15	90003-ZE3-600	BOLT, HEX., 3/8-24UNF(25MM)	1	-	-	-----	LT,LT/A
	92000-08025-0A	BOLT, HEX., 8X25	-	(1)	-	-----	L1
	92101-08025-0A		-	(1)	-	4847898	L1/A
			1	-	-	-----	LJ,LJ/A,LJG,LJG/A,LJG1,LJS,LJS/A,LK,LM9,LNJ,LNZ,LSS4,LSS5,LSS5/A
			-	(1)	-	4847899	L1/A



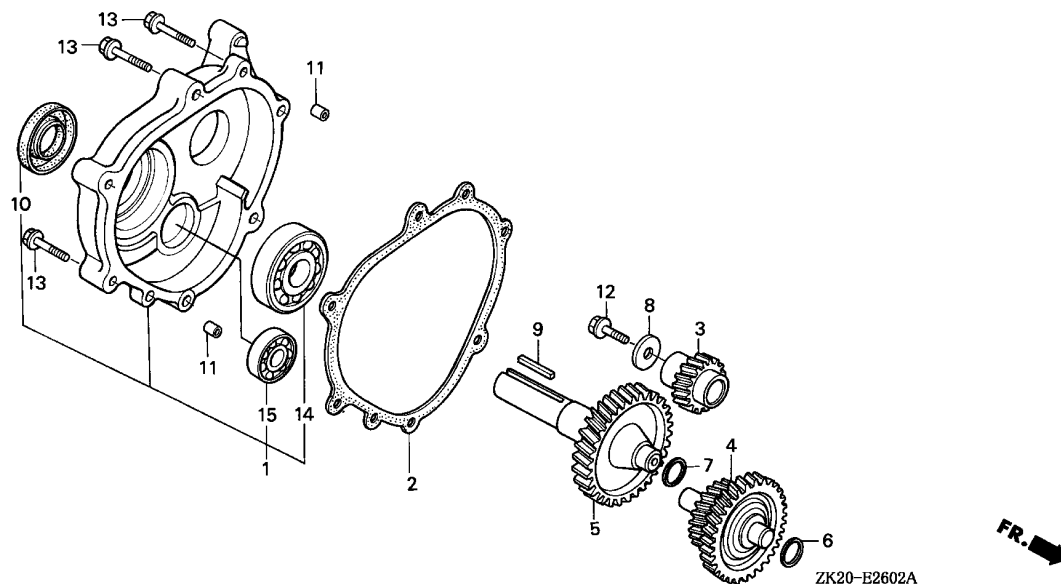

Ref. No.	L.O.N.	(Relative ref. Number) Description	F.R.T.
1		(2)	
	2141W8	COVER, REDUCTION AND/OR PACKING, REDUCTION COVER (H-TYPE)	0.2
3	2141L2	GEAR, PRIMARY DRIVE	0.2
4	2141Z9	COUNTERSHAFT, REDUCTION (H-TYPE)	0.2
5	2141V9	SHAFT, POWER TAKE OFF(H-TYPE)	0.2
10	2141X5	OIL SEAL, POWER TAKE OFF SHAFT (H-TYPE) :REAR	0.2
14	2141Y0	BEARING, POWER TAKE OFF SHAFT (H-TYPE) :REAR	0.3
15	2141AA	BEARING, REDUCTION COUNTERSHAFT(H-TYPE) :REAR ..	0.3

Ref. No.	Part No.	Description	Reqd. QTY			Serial No.	Parts catalogue code
			(1)	(2)	(3)		
			GX240K1				
1	11500-ZE2-620	COVER ASSY., REDUCTION CASE ..	1	-	-	HA,HAQ,HA2,HA2/A,HH,HHQ4,HHQ4/A,HTX,HX,HX/A,HXQ4,HXQ4/A	
2	11521-ZE2-800	PACKING, CHAIN CASE COVER ..	1	-	-	HA,HAQ,HA2,HA2/A,HH,HHQ4,HHQ4/A,HTX,HX,HX/A,HXQ4,HXQ4/A	
3	22103-ZE2-620	GEAR, PRIMARY DRIVE (17T) ..	1	-	-	HA,HAQ,HA2,HA2/A,HH,HHQ4,HHQ4/A,HTX,HX,HX/A,HXQ4,HXQ4/A	
4	23220-ZE2-621	COUNTERSHAFT COMP.	1	-	-	HA,HAQ,HA2,HA2/A,HH,HHQ4,HHQ4/A,HTX,HX,HX/A,HXQ4,HXQ4/A	
5	23710-ZE2-R20	SHAFT, P.T.O.	1	-	-	HTX	
	23710-ZE2-621	SHAFT, P.T.O. (46T)	1	-	-	HA,HAQ,HA2,HA2/A,HH,HHQ4,HHQ4/A,HX,HX/A,HXQ4,HXQ4/A	
6	90401-ZE2-620	SHIM A	(N)	-	-	HA,HAQ,HA2,HA2/A,HH,HHQ4,HHQ4/A,HTX,HX,HX/A,HXQ4,HXQ4/A	
7	90402-ZE2-620	SHIM B	(N)	-	-	HA,HAQ,HA2,HA2/A,HH,HHQ4,HHQ4/A,HTX,HX,HX/A,HXQ4,HXQ4/A	
8	90473-842-000	WASHER, 8MM	1	-	-	HA,HAQ,HA2,HA2/A,HH,HHQ4,HHQ4/A,HTX,HX,HX/A,HXQ4,HXQ4/A	
9	90745-ZE2-600	KEY, 6.3X6.3X43	1	-	-	HA,HAQ,HA2,HA2/A,HH,HHQ4,HHQ4/A,HX,HX/A,HXQ4,HXQ4/A	
10	91201-890-003	OIL SEAL, 30X46X8	1	-	-	HA,HAQ,HA2,HA2/A,HH,HHQ4,HHQ4/A,HTX,HX,HX/A,HXQ4,HXQ4/A	
11	94301-08140	DOWEL PIN, 8X14	2	-	-	HA,HAQ,HA2,HA2/A,HH,HHQ4,HHQ4/A,HTX,HX,HX/A,HXQ4,HXQ4/A	
12	95701-08025-00	BOLT, FLANGE, 8X25	1	-	-	HA,HAQ,HA2,HA2/A,HH,HHQ4,HHQ4/A,HTX,HX,HX/A,HXQ4,HXQ4/A	
13	95701-08035-00	BOLT, FLANGE, 8X35	6	-	-	HTX	
	95701-08040-00	BOLT, FLANGE, 8X40	6	-	-	HA,HAQ,HA2,HA2/A,HH,HHQ4,HHQ4/A,HX,HX/A,HXQ4,HXQ4/A	
14	96100-62060-00	BEARING, RADIAL BALL, 6206 ..	1	-	-	HA,HAQ,HA2,HA2/A,HH,HHQ4,HHQ4/A,HTX,HX,HX/A,HXQ4,HXQ4/A	
15	96100-63020-00	BEARING, RADIAL BALL, 6302 ..	1	-	-	HA,HAQ,HA2,HA2/A,HH,HHQ4,HHQ4/A,HTX,HX,HX/A,HXQ4,HXQ4/A	

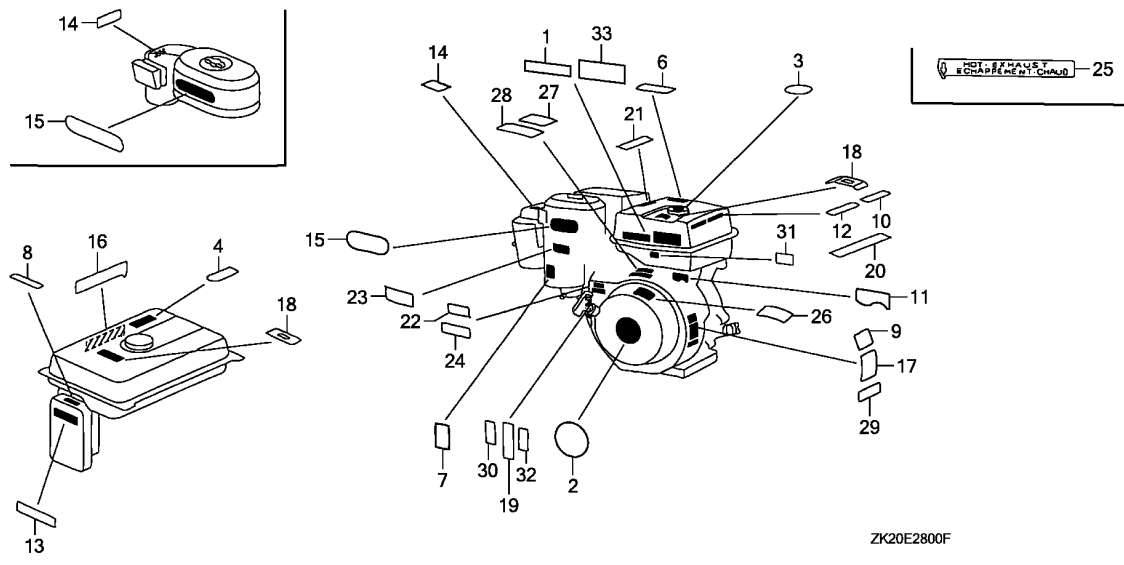

Ref. No.	L.O.N.	(Relative ref. Number) Description	F.R.T.
----------	--------	------------------------------------	--------

NO INFORMATION

Ref. No.	Part No.	Description	Reqd. QTY			Serial No.	Parts catalogue code
			(1)	(2)	(3)		
1	87520-ZH8-000	MARK A, COMBINATION	1	(1)	-	-----	LJ/A,LJG/A,LJG1,LJS,LJS/A,LSS5,LSS5/A,LSX,LSX/A,LXF,L1/A,RJ/A RSS1,RSS1/A,R1/A,SHW,SHW/A,SJ/A,SJC1,SJC1/A,SJC5,SJC5/A,SJG/A SMS/A,SNR/A,STP/A,S1/A,WJ/A
			1	(1)	-	3398936	HTX,LJ,LJG,LK,LM9,LNJ,LNZ,L1,RJ,R1,SJ,SJC,SJG,SJP,SK,SNR,STP,S1 WJ,WKA
	87522-ZH9-000	LABEL, CAUTION (ENGLISH, ETC.)	1	-	-	3410599	SMS
			1	-	-	-----	ED3,ES,HA,HAQ,HH,LD,LDB1,LDB3,LHE,LHZ,LW,LXZ,PA,PAE,QA,QAE,QAQ QDA,QHC,QHE,QHZ,QKA2,QMX2,QXEB,RA,RH,RHE,SDB1,SH,SHE,SHSZ,SW,SWE SXE,SXEB,VA,VMX,VNG,WH
			1	-	-	3139853	VTA
			1	-	-	3302521	QE,QXB,SE,SXB
	87522-ZH9-820	LABEL, CAUTION (THAI)	1	-	-	-----	LT,QT
			1	-	-	4567728	LT/A,QT/A
	87522-ZH8-W40	MARK, CAUTION (PICTOGRAPH) ..	1	-	-	-----	HHQ4,HXQ4,LHE4,LXQ4,QAQ4,QHQ4,QXB7,QXE4,QXQ4,RHE4,RHQ4,RXQ4,SNC1 SNE1,SXE4,SXQ4,VXB7,VXQ4,VXQ7,WKT4
			1	-	-	3302522	QE,QXB,SE,SXB
			1	-	-	3684579	LSS4
			1	-	-	4528690	HHQ4/A,HXQ4/A,LHE4/A,LXQ4/A,QAQ4/A,QHQ4/A,QXB7/A,QXE4/A,QXQ4/A RHQ4/A,RXQ4/A,SE/A,SXE4/A,SXQ4/A,VXB7/A,VXQ4/A,VXQ7/A,WKT4/A
	87522-ZH9-010	LABEL, CAUTION (ENGLISH, ETC.)	1	-	-	-----	ED4,ED4/A,ED5,ED5/A,ES1,ES1/A,HA2,HA2/A,HX,HX/A,LH,LH/A,LP,LP/A LX,LX/A,LX2,LX2/A,PA2,PA2/A,PMT2,PMT2/A,PX,PX/A,QAB2,QAB2/A,QAE2 QAE2/A,QAG,QAG/A,QAG2,QAG2/A,QAR2,QAR2/A,QA2,QA2/A,QC12,QC12/A,QD QD/A,QH,QH/A,QHB2,QHP1,QHP1/A,QMH,QMH/A,QP,QP/A,QTC2,QTC2/A,QX QX/A,QXC,QXC/A,QXC9,QXC9/A,QXE,QXE/A,QXU,QXU/A,RA2,RA2/A,RD,RD/A RTB2,RTB2/A,RX,RX/A,SD,SD/A,SDB3,SDB3/A,SMX2,SMX2/A,STP,STP/A,STQ STQ/A,SX,SX/A,SXU,SXU/A,VA2,VA2/A,VDG2,VDG2/A,VH,VH/A,VWC2,VX VX/A,VXB,VXB/A,VXE,VXE/A,VXB,VXB/A,VXU,VXU/A,VXU1,VXU1/A,WKD6 WKD6/A,WKT2,WKT2/A,WMK
			-	(1)	-	-----	



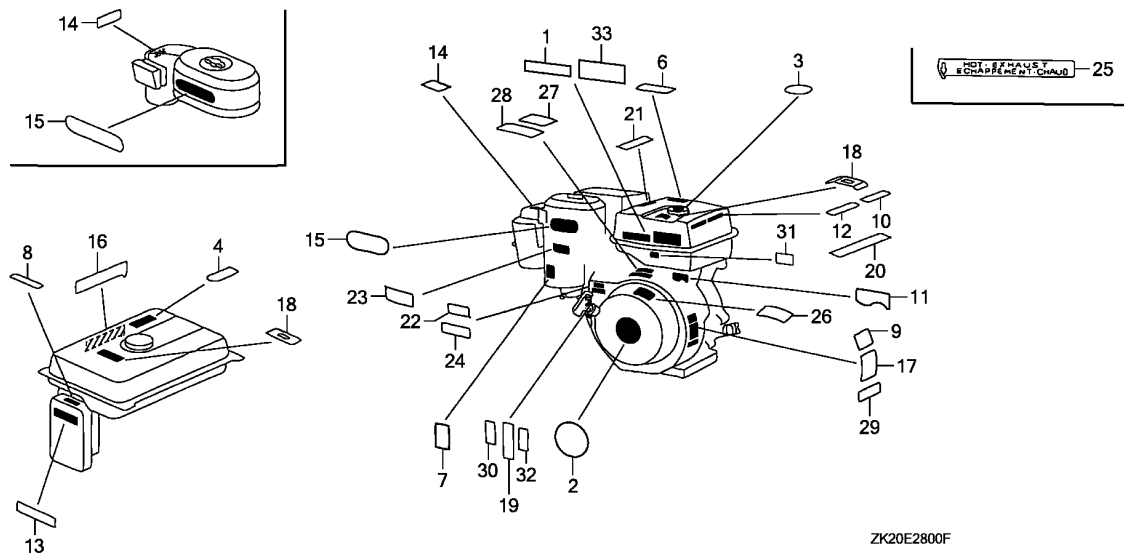

ZK20E2800F

Ref. No.	Part No.	Description	Reqd. QTY			Serial No.	Parts catalogue code
			GX240K1				
			(1)	(2)	(3)		
(1)	87522-ZH9-821	LABEL, CAUTION (THAI)	1	-	-	4567729	LT/A,QT/A
	87525-ZE2-810	EMBLEM, UPPER (EXTERNAL)	1	-	-	-----	LKS,LKS/A
	87522-ZH8-W41	MARK, CAUTION (PICTOGRAPH) ..	1	-	-	-----	QHB2
			1	-	-	4528691	HHQ4/A,HXQ4/A,LHE4/A,LXQ4/A,QE/A,QHQ4/A,QXB7/A,QXE4/A,QXQ4/A,RHQ4/A,RXQ4/A,SE/A,SXE4/A,SXQ4/A,VXB7/A,VXQ4/A,VXQ7/A,WKT4/A
2	87521-ZE2-W01	EMBLEM (GX240 HONDA 8.0)	1	(1)	-	3117235	4192760 ED2,ES1,ES3,HX,LH,LJ,LP,LX,L1,PX,P1,QD,QE,QH,QP,QT,QX,QXC,QXE,Q1
			1	-	-	-----	RD,RJ,RX,R1,SD,SE,SJ,SX,S1,VH,VX,VXB,VXE,VXEB,V1,WJ,W1
			1	-	-	-----	EDN,EDS,EDS3,EDT2,HAQ,HTX,LDB1,LHZ,LJG1,LM9,LNJ,LNZ,QAQ,QA2,QMX2
			1	-	-	3117235	----- RHE4,RSC2,SDB1,SJC,SNC1,SNE1,VMX,VTE2
			1	-	-	-----	ED3,EN,ES,ET,ETS,ETX,HA,HH,LD,LHE,LK,LW,LXZ,PA,PAE,QA,QAE,QHC,QHE
			1	-	-	-----	QXB,QXEB,RA,RH,RHE,SH,SHE,SHEZ,SJP,SK,SW,SWE,SXB,SXE,SXEB,VA,VAH1
			1	-	-	-----	VNG,VTA,WH,WKA
			1	-	-	-----	4192760 EDN2,EDS1,EDS2,EDS6,EDT1,EDT6,ED4,ED5,EN2,HA2,HHQ4,HXQ4,LJG,LJS
			1	-	-	-----	LSS5,LSX,LX2,PA2,PMT2,QAB2,QAE2,QAG2,QAR2,QA2,QC12,QMH,QTC2,QXC9
			1	-	-	-----	QXE4,QXQ4,QXU,RA2,RHQ4,RSS1,RTB2,RXQ4,SDB3,SJC1,SJC5,SJG,SMS,SMX2
			1	-	-	-----	SNR,STP,STQ,SXE4,SXQ4,SXU,VA2,VDG2,VH12,VSB1,VTA2,VWC2,VXQ4,VXU
			1	-	-	-----	VXU1,WKD6,WKT2,WKT4
	87521-ZE2-W10	EMBLEM (GX240 HONDA 8.0 HP) .	1	-	-	-----	QDA
	87570-765-000	PLATE, EMBLEM	1	-	-	-----	LM9

Ref. No.	Part No.	Description	Reqd. QTY			Serial No.	Parts catalogue code
			(1)	(2)	(3)		
(2)	87521-ZE2-W02	EMBLEM (GX240 HONDA 8.0)	1	(1)	-	4192761	----- EDN2,EDS1,EDS2,EDS6,EDT1,EDT6,ED2,ED4,ED5,EN2,ES1,ES3,HA2,HHQ4,HXHXQ4,LH,LJ,LJG,LJS,LP,LSS5,LSX,LX,LX2,L1,PA2,PMT2,PX,P1,QAB2,QAE2QAG2,QAR2,QA2,QC12,QD,QE,QH,QMH,QP,QT,QTC2,QX,QXC,QXC9,QXE,QXE4QXQ4,QXU,Q1,RA2,RD,RHQ4,RJ,RSS1,RTB2,RX,RXQ4,R1,SD,SDB3,SE,SJSJC1,SJC5,SJG,SMS,SMX2,SNR,STP,STQ,SX,SXE4, SXQ4, SXU, S1, VA2, VDG2VH,VH12,VSB1,VTA2,VWC2,VX,VXB,VXE,VXEB,VXQ4,VXU,VXU1,V1,WJ,WKD6WKT2,WKT4,W1
			1	(1)	-	4465232	----- EDN2/A,EDS1/A,EDS2/A,EDS6/A,EDT1/A,EDT6/A,ED2/A,ED4/A,ED5/A,EN2/AES1/A,ES3/A,HA2/A,HHQ4/A,HX/A,HXQ4/A,LH/A,LHE4/A,LJ/A,LJG/A,LJS/A,LP/A,LSS5/A,LSX/A,LT/A,LX/A,LXQ4/A,LX2/A,L1/A,PA2/A,PMT2/A,PX/AQAB2/A,QAE2/A,QAG/A,QAG2/A,QAR2/A,QA2/A,QC12/A,QD/A,QE/A,QH/AQHP1/A,QHQ4/A,QMH/A,QP/A,QT/A,QTC2/A,QX/A,QXB7/A,QXC/A,QXC9/AQXE/A,QXE4/A,QXQ4/A,QXU/A,Q1/A,RA2/A,RD/A,RHQ4/A,RJ/A,RSS1/ARTB2/A,RX/A,RXQ4/A,R1/A,SD/A,SDB3/A,SE/A,SJ/A,SJC1/A,SJC5/A,SJG/ASMS/A,SMX2/A,SNR/A,STP/A,STQ/A,SX/A,SXE4/A, SXQ4/A, SXU/A, S1/AVA2/A,VDG2/A,VH/A,VH12/A,VSB1/A,VTA2/A,VWC2/A,VX/A,VXB/A,VXB7/AVXE/A,VXEB/A,VXQ4/A,VXQ7/A,VXU/A,VXU1/A,WJ/A,WKD6/A,WKT2/A,WKT4/AW1/A
	87521-ZE2-W03	1	-	1	4465233	----- LHE4,LT,LXQ4,QAG,QHP1,QHQ4,QXB7,SHW,SHW/A,VXB7,VXP,VXP/A,VXQ7EDS1/A,EDT1/A,ED5/A,ES1/A,ES3/A,HX/A,LH/A,LJ/A,LJG/A,LJS/A,LP/A,LSX/A,LT/A,LX/A,L1/A,PX/A,QD/A,QH/A,QHP1/A,QMH/A,QP/A,QT/A,QX/AQXC/A,QXE/A,Q1/A,RD/A,RJ/A,RSS1/A,RX/A,R1/A,SD/A,SDB3/A,SJ/A,SJC1/A,SJC5/A,SJG/A,SMS/A,SNR/A,STP/A,SX/A,S1/A,VH/A,VSB1/A,VX/AVXE/A,VXEB/A,VXU/A,WJ/A,W1/A
			1	-	-	4465233	----- QHB2,QW24,VMT2
			1	-	-	4847660	----- EDN2/A,EDS2/A,EDS6/A,EDT6/A,ED2/A,ED4/A,EN2/A,HA2/A,HHQ4/A,HXQ4/ALHE4/A,LSS5/A,LXQ4/A,LX2/A,PA2/A,PMT2/A,QAB2/A,QAE2/A,QAG/AQAG2/A,QAR2/A,QA2/A,QC12/A,QE/A,QHQ4/A,QTC2/A,QXB7/A,QXC9/AQXE4/A,QXQ4/A,QXU/A,RA2/A,RHQ4/A,RTB2/A,RXQ4/A,SE/A,SMX2/A,STQ/ASXE4/A, SXQ4/A, SXU/A, VA2/A, VDG2/A, VH12/A, VTA2/A, VWC2/A, VXB/AVXB7/A,VXQ4/A,VXQ7/A,VXU1/A,WKD6/A,WKT2/A,WKT4/A
	87521-ZE2-W04	EMBLEM (GX240)	1	(1)	-	4847661	----- LXF,VS3
			1	-	-	3165402	----- EDS1/A,EDT1/A,ED5/A,ES1/A,ES3/A,HX/A,LH/A,LJ/A,LJG/A,LJS/A,LP/A,LSX/A,LT/A,LX/A,LXF,L1/A,PX/A,QD/A,QH/A,QHP1/A,QMH/A,QP/A,QT/AQX/A,QXC/A,QXE/A,Q1/A,RD/A,RJ/A,RSS1/A,RX/A,R1/A,SD/A,SDB3/A,SJ/ASJC1/A,SJC5/A,SJG/A,SMS/A,SNR/A,STP/A,SX/A,S1/A,VH/A,VSB1/A,VS3VX/A,VXE/A,VXEB/A,VXU/A,WJ/A,W1/A
3	87522-ZE1-010	LABEL, FUEL WARNING	1	(1)	-	3165403	----- EDT3,ES2,WMK
	87522-ZE1-810	MARK, CAUTION	1	(1)	-	3254423	----- EN,ET,ETS,ETX,HTX,LJ,LK,LM9,LNJ,L1,P1,Q1,RJ,R1,SJ,SK,SNR,S1,V1,WJWKA,W1
			1	-	-	3139853	----- LDB1,LDB3,LT,LT/A,QT,QT/A,SDB1,SDB3,SDB3/A,STP,STQ
			1	-	-	3254423	----- VTA
			1	-	-	3254423	----- ED3,ED4,ED5,ES,ES1,HA,HAQ,HA2,HH,HX,LD,LH,LHE,LKS,LNZ,LP,LW,LXLXZ,LX2,PA,PAE,PA2,PX,QA,QAE,QAE2,QAQ,QA2,QD,QDA,QE,QH,QHC,QHE,QPQX,QXB,QXC,QXE,QXEB,RA,RA2,RD,RH,RHE,RX,SD,SE,SH,SHE,SHEZ,SW,SWESX,SXB,SXE,SXEB,VA,VA2,VH,VNG,VX,VXB,VXE,VXEB,VXU,W1
4	87522-883-660	MARK, CAUTION (ENGLISH/FRENCH/SPANISH)	1	-	-	-----	----- EDS,EDS1,EDS1/A,EDS2,EDS2/A,EDS3,EDS5,EDS6,EDS6/A,EDT1,EDT1/AEDT2,EDT6,EDT6/A,ED2,ED2/A,EN2,VTE2
6	87526-ZH8-000	MARK B, COMBINATION	1	(1)	-	-----	----- LJ/A,LJG/A,LJG1,LJS,LJS/A,LSS5,LSS5/A,LSX,LSX/A,LXF,L1/A,RJ/ARSS1,RSS1/A,R1/A,SHW,SHW/A,SJ/A,SJC1,SJC1/A,SJC5,SJC5/A,SJG/ASMS/A,SNR/A,STP/A,S1/A,WJ/A
			1	(1)	-	3398936	----- HTX,LJ,LJG,LK,LM9,LNJ,LNZ,L1,RJ,R1,SJ,SJC,SJG,SJP,SK,SNR,STP,S1WJ,WKA
			1	-	-	3410599	----- SMS
7	87528-ZE1-690	MARK, CHOKE (THAI)	1	-	-	-----	----- LT,LT/A,QT,QT/A



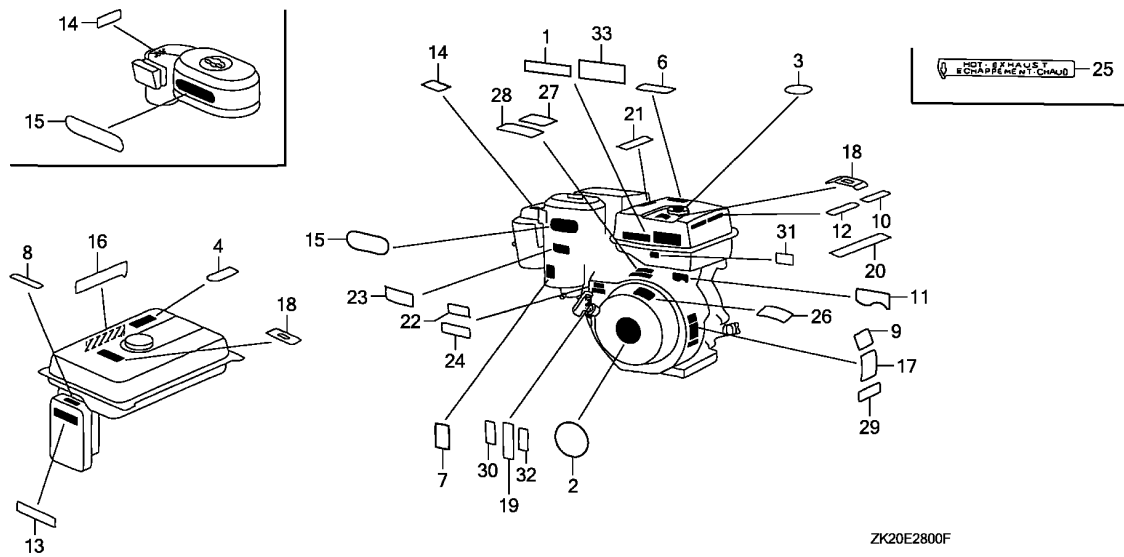

Ref. No.	Part No.	Description	Reqd. QTY			Serial No.	Parts catalogue code
			(1)	(2)	(3)		
(7)	87528-ZE2-000	MARK, CHOKE (INTERNAL)	1	(1)	-	3165402	HTX,LJ,LK,LM9,LNJ,L1,P1,Q1,RJ,R1,SJ,SJP,SK,SNR,S1,V1,WJ,W1
	87528-ZE2-810	MARK, CHOKE (ORANGE)	1	-	-	-----	ED3,ED4,ED4/A,ED5,ED5/A,EN,ES,ES1,ES1/A,ES2,ET,ETS,ETX,HA,HAQ,HA2,HA2/A,HH,HX,HX/A,LD,LDB1,LDB3,LH,LH/A,LHE,LHZ,LJ/A,LJG,LJG/A,LJG1,LJS,LJS/A,LNZ,LP,LP/A,LSS5,LSS5/A,LSX,LSX/A,LW,LX,LX/A,LXF,LXZ,LX2,LX2/A,PA,PAE,PA2,PA2/A,PMT2,PMT2/A,PX,PX/A,QA,QAB2,QAB2/A,QAE,QAE2,QAE2/A,QAG,QAG/A,QAG2,QAG2/A,QAQ,QAR2,QAR2/A,QA2,QA2/A,QC12,QC12/A,QD,QD/A,QDA,QH,QH/A,QHB2,QHC,QHE,QHP1,QHP1/A,QHZ,QKA2,QMH,QMH/A,QMX2,QP,QP/A,QTC2,QTC2/A,QX,QX/A,QXC,QXC/A,QXC9,QXC9/A,QXE,QXE/A,QXEB,QXU,QXU/A,RA,RA2,RA2/A,RD,RD/A,RH,RHE,RJ/A,RSC2,RSS1,RSS1/A,RTB2,RTB2/A,RX,RX/A,SD,SD/A,SDB1,SDB3,SDB3/A,SH,SHE,SHEZ,SJ/A,SJC,SJC1,SJC1/A,SJC5,SJC5/A,SJG,SJG/A,SMS,SMS/A,SMX2,SMX2/A,SNR/A,STP,STP/A,STQ,STQ/A,SW,SWE,SX,SX/A,SXE,SXEB,SXU,SXU/A,VA,VAH1,VA2,VA2/A,VDG2,VDG2/A,VH,VH/A,VH12,VH12/A,VMX,VNG,VTA,VTA2,VTA2/A,VWC2,VWC2/A,VX,VX/A,VXB,VXB/A,VXE,VXE/A,VXEB,VXEB/A,VXU,VXU/A,VXU1,VXU1/A,WH,WJ/A,WKD6,WKD6/A,WKT2,WKT2/A,WMK
			1	-	-	3165403	HTX,LJ,LK,LM9,LNJ,RJ,SJ,SJP,SK,SNR,WJ
			1	-	-	3302521	QE,QXB,SE,SXB
			-	(1)	-	4825237	S1/A
	87528-ZF6-W40	MARK, CHOKE (BLACK)	1	-	-	-----	HHQ4,HHQ4/A,HXQ4,HXQ4/A,LHE4,LHE4/A,LSS4,LXQ4,LXQ4/A,QAQ4,QE/A,QHB2,QHQ4,QHQ4/A,QXB7,QXB7/A,QXE4,QXE4/A,QXQ4,QXQ4/A,RHE4,RHQ4,RHQ4/A,RXQ4,RXQ4/A,SE/A,SNC1,SXE4,SXE4/A,SXQ4,SXQ4/A,VXB7,VXB7/A,VXQ4,VXQ4/A,VXQ7,VXQ7/A,WKT4,WKT4/A
	87528-883-661	MARK, CHOKE	-	-	1	3302522	QE,QXB,SE,SXB
	87528-ZH7-000	MARK, CHOKE (GRAY)	1	-	-	4734392	HA2/A,PA2/A,RA2/A,VWC2/A
8	87528-898-620	MARK, CHOKE	1	-	-	-----	EDN,EDN2,EDN2/A,EDS,EDS1,EDS1/A,EDS2,EDS2/A,EDS3,EDS6,EDS6/A,EDT1,EDT1/A,EDT2,EDT3,EDT6,EDT6/A,ED2,ED2/A,EN2,EN2/A,ES3,ES3/A,VSB1,VSB1/A,VS3,VS4,VTE2

Ref. No.	Part No.	Description	Reqd. QTY			Serial No.	Parts catalogue code
			(1)	(2)	(3)		
9	87530-ZE2-W10	LABEL, SPECIFICATION (EXTERNAL)	1	-	-	3165402	EDN,EDS,ED2,ED3,ED4,ED5,EN,ES,ES1,ES3,ET,ETS,ETX,HA,HAQ,HH,HX,LD LH,LHE,LP,LW,LX,LXZ,PA,PX,QA,QAE,QAQ,QD,QDA,QE,QH,QHC,QHE,QP,QT QX,QXB,QXC,QXE,QXEB,RA,RD,RH,RHE,RX,SD,SE,SH,SHE,SHEZ,SW,SWE,SX SXB,SXE,SXEB,VA,VAH1,VH,VNG,VTA,VX,VXB,VXE,VXEB,WH
	87530-ZE2-000	SUB EMBLEM (INTERNAL)	-	(1)	-		Q1,R1,S1,W1
	87530-ZE2-810	SUB EMBLEM (EXTERNAL)	1	-	-		LKS,LKS/A
	87530-ZE2-820	SUB EMBLEM (INTERNAL)	-	(1)	-		L1
	87530-ZE2-W01	LABEL, SPECIFICATION	1	(1)	-		HTX,LK,P1,Q1,Q1/A,RJ,RJ/A,RSS1,RSS1/A,R1,R1/A,SJ,SJ/A,SJC,SJC1 SJC1/A,SJC5,SJC5/A,SJG,SJG/A,SJP,SK,SMS,SMS/A,SNR,SNR/A,S1,S1/A V1,WJ,WJ/A,WKA,W1,W1/A
	87530-ZE2-W41	1	(1)	-		LJ,LJ/A,LJG,LJG/A,LJG1,LJS,LJS/A,LK,LM9,LNJ,LNZ,LSS5,LSS5/A,L1 L1/A
10	87532-ZB4-G60	MARK, OIL ALERT (GERMAN)	1	(1)	-	3171791	ED5,ES1,HA,HAQ,HA2,HX,LX,LXZ,LX2,L1,PA,PA2,PX,P1,QA,QAE,QAE2,QAQ QA2,QX,QXB,QXC,QXE,QXEB,Q1,RA,RA2,RX,R1,SX,SXB,SXE,SXEB,S1,VA,VA2 VNG,VTA,VX,VXB,VXE,VXEB,V1,W1
	87532-ZB4-H50	MARK, OIL ALERT (FRENCH)	1	(1)	-	3171791	PAE,PMT2,QAG2,QKA2,QXC9,QXU,RSC2,SMX2,SXU,VXU,VXU1,WKT2 ED5,ES1,HAQ,HA2,HX,LX,LXZ,LX2,L1,PA2,PX,QA,QAE,QAE2,QAQ,QA2,QX QXB,QXC,QXE,QXEB,RA2,RX,R1,SX,SXB,SXE,SXEB,VA2,VNG,VX,VXB,VXE VXEB
			1	-	-		PMT2,QAG2,QKA2,QXC9,QXU,RSC2,SMX2,SXU,VXU,VXU1,WKD6,WKD6/A,WKT2
			-	(1)	-	3171791	3481104 P1,Q1,S1,V1,W1
11	87532-ZE1-000	MARK, OIL ALERT (INTERNAL)	1	(1)	-	3116814	L1,P1,Q1,R1,SJP,SNR,S1,V1,W1
	87532-ZE1-810	MARK, OIL ALERT (EXTERNAL)	1	-	-	3116814	ES1,HA,HX,LX,LXZ,PA,PX,QA,QX,QXB,QXC,RA,RX,SX,SXB,VA,VAH1,VNG,VX VXB
12	87532-ZH8-000	MARK, OIL ALERT (INTERNAL)	1	(1)	-		LSX,LSX/A,LXF,L1/A,Q1/A,R1/A,SJC1,SJC1/A,SJC5,SJC5/A,SMS,SMS/A SNR/A,S1/A,W1/A
	87532-ZH8-810	MARK, OIL ALERT (EXTERNAL)	1	(1)	-	3116815	L1,P1,Q1,R1,SJP,SNR,S1,V1,W1
			1	-	-		ED5,ED5/A,ES1/A,ES2,HAQ,HA2,HX/A,LX/A,LX2,LX2/A,PAE,PA2,PMT2 PMT2/A,PX/A,QAB2,QAB2/A,QAE2,QAE2/A,QAG,QAG/A,QAG2,QAG2/A,QAQ QAR2,QAR2/A,QA2,QA2/A,QKA2,QMX2,QTC2,QTC2/A,QX/A,QXC/A,QXC9 QXC9/A,QXE/A,QXU,QXU/A,RA2,RSC2,RTB2,RTB2/A,RX/A,SMX2,SMX2/A,SX/A SXU,SXU/A,VA2,VA2/A,VDG2,VDG2/A,VMX,VTA,VTA2,VTA2/A,VWC2,VX/A VXB/A,VXE/A,VXEB/A,VXU,VXU/A,VXU1,VXU1/A,WKD6,WKD6/A,WKT2,WKT2/A
			1	-	-	3116815	ES1,HA,HX,LX,LXZ,PA,PX,QA,QAE,QX,QXC,QXE,QXEB,RA,RX,SX,SXE,SXEB VA,VNG,VX,VXB,VXE,VXEB
			1	-	-	4734391	HA2/A,PA2/A,RA2/A
			1	-	-	3116815	QXB,SXB
			1	-	-		ES2
13	87533-ZB6-750	MARK, AIR CLEANER	1	-	-		EDS5
	87533-ZC0-630	1	-	-		EDN,EDN2,EDN2/A,EDS,EDS1,EDS1/A,EDS2,EDS2/A,EDS3,EDS6,EDS6/A,EDT1 EDT1/A,EDT2,EDT6,EDT6/A,ED2,ED2/A,EN2,EN2/A,ES3,ES3/A,VS1,VS1/A VS3,VTE2
14	87534-ZE1-841	LABEL, AIR CLEANER CAUTION	1	-	-		QHC,QXC,QXC/A,QXC9,QXC9/A
			-	(1)	-		
15	87535-ZE1-840	MARK, AIR CLEANER SALES POINT	1	(1)	-		LSS4,L1,P1,QHC,QXC,QXC9,Q1,R1,S1,V1,W1
			1	(1)	-	4466592	L1/A,QXC/A,QXC9/A,Q1/A,R1/A,S1/A,W1/A
	87535-ZE1-841	1	(1)	-	4466593	L1/A,QXC/A,QXC9/A,Q1/A,R1/A,S1/A,W1/A
16	87539-ZB2-630	MARK, EX. CAUTION	1	-	-		EDS5
	87539-898-620	MARK, EX. CAUTION (ENGLISH/FRENCH)	1	-	-		EDT2
17	87594-ZB4-A00	MARK, OIL CAUTION	1	-	-		EDN,EDN2,EDN2/A,EDS,EDS1,EDS1/A,EDS2,EDS2/A,EDS3,EDS5,EDS6,EDS6/A EDT1,EDT1/A,EDT2,EDT3,EDT6,EDT6/A,ED2,ED2/A,EN2,EN2/A,ES,ES1 ES1/A,ES2,VTE2



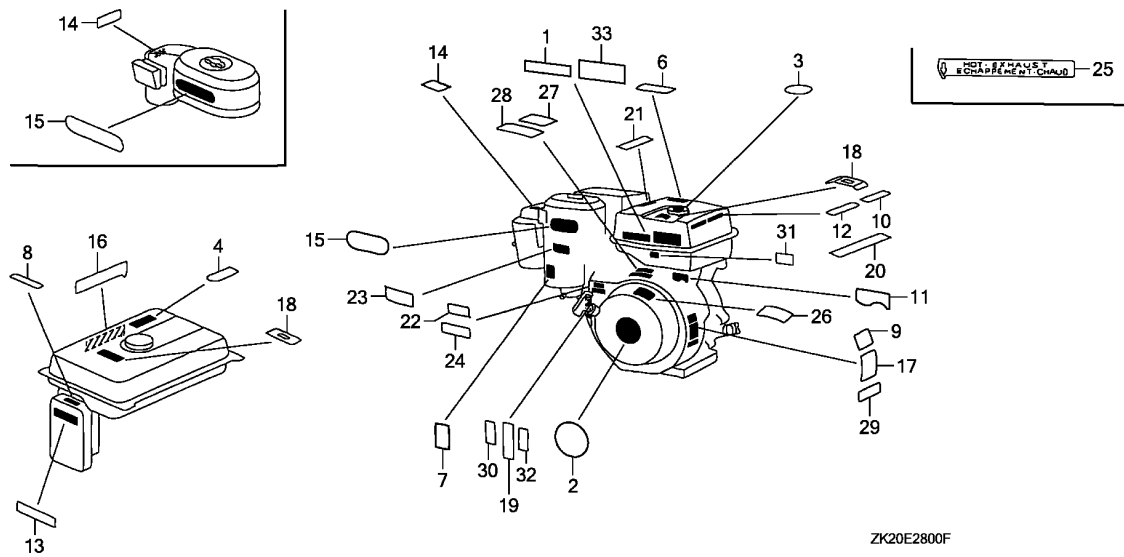

ZK20E2800F

Ref. No.	Part No.	Description	Reqd. QTY			Serial No.	Parts catalogue code
			GX240K1				
			(1)	(2)	(3)		
18	87565-ZE2-000	MARK, FUEL INDICATION (JAPANESE)	1	(1)	-	-----	HTX,LJG/A,LJG1,LJS,LJS/A,LM9,LNJ,LSS5/A,LXF,P1,RSS1/A,SJG/A,SMS/A SNR/A,V1,W1/A
			1	(1)	-	4081616	LJG,LNZ,LSS5,L1,Q1,RSS1,R1,SJG,SMS,SNR,S1,W1
19	87532-ZB4-H50	MARK, OIL ALERT (FRENCH)	1	-	-	4475052	SHW/A
20	87532-ZB4-G60	MARK, OIL ALERT (GERMAN)	1	-	-	3171791	PAE,QAR2,RTB2,VWC2 HA,PA,RA,VA,VTA
	87565-ZB4-A00	PLATE, FUEL INDICATION	1	-	-	-----	QAR2,RTB2,VWC2 EDS,EDS5,ED2,ED2/A,VTE2
21	87586-ZH7-W00	LABEL, FUEL CAUTION	1	-	-	3333248	HAQ,HA2,LX2,PA2,QAE2,QAQ,QA2,RA2,VA2
22	87124-ZV3-010	MARK, EMERGENCY SWITCH INDICATION	-	-	1	-----	-----
23	87524-883-690	MARK, AIR CLEANER CAUTION (OIL BATH)(ARABIC)	1	-	-	-----	LP,LP/A,LT,LT/A,LW,QP,QP/A,QT,QT/A,SW,SWE
24	87532-ZH8-W40	MARK, THROTTLE INDICATION ...	1	-	-	-----	HHQ4,HHQ4/A,HXQ4,HXQ4/A,LHE4,LHE4/A,LSS4,LXQ4,LXQ4/A,QAQ4,QE/A QHB2,QHQ4,QHQ4/A,QXB7,QXB7/A,QXE4,QXE4/A,QXQ4,QXQ4/A,RHE4,RHQ4 RHQ4/A,RXQ4,RXQ4/A,SE/A,SNC1,SNE1,SXE4,SXE4/A,SXQ4,SXQ4/A,VXB7 VXB7/A,VXQ4,VXQ4/A,VXQ7,VXQ7/A,WKT4,WKT4/A
			1	-	-	3302522	QE,QXB,SE,SXB
			1	-	-	4734392	HA2/A,PA2/A,RA2/A,VWC2/A
25	87539-898-620	MARK, EX. CAUTION (ENGLISH/FRENCH)	1	-	-	-----	EDS,EDS1,EDS1/A,EDS2,EDS2/A,EDS3,EDS6,EDS6/A,EDT1,EDT1/A,EDT6 EDT6/A,ED2,ED2/A,ES3,ES3/A,VS1,VS1/A,VS3,VTE2
26	87586-ZH7-W00	LABEL, FUEL CAUTION	2	-	-	3337057	ED2
27	87522-ZH8-W40	MARK, CAUTION (PICTOGRAPH) ..	-	-	1	-----	VXQP
28	87522-ZH9-010	LABEL, CAUTION (ENGLISH, ETC.)	-	-	1	-----	VXP,VXP/A

Ref. No.	Part No.	Description	Reqd. QTY			Serial No.	Parts catalogue code
			(1)	(2)	(3)		
29	87532-ZH8-810	MARK, OIL ALERT (EXTERNAL) ..	-	-	1	-----	VXP,VXP/A
30	87135-ZE2-000	LABEL, E-SPEC (HONDA) (EPA STANDARD)(15.5X60.0)	1	-	1	-----	4217821 EDS6,EDT6,VXP
			1	-	-	-----	4081617 VMX
			1	-	-	-----	4081617 4217821 EDS1,EDT1
			-	-	1	-----	VXQP
	87135-ZE2-010	LABEL, E-SPEC (EPA STANDARD) (15.5X60.0)	1	-	1	-----	4217822 EDS1,EDS6,EDT1,EDT6,VXP
	87135-ZE2-020	LABEL, E-SPEC (15.5X27.5) ...	-	-	1	-----	VXP/A
31	87135-ZE2-000	LABEL, E-SPEC (HONDA) (EPA STANDARD)(15.5X60.0)	1	1	-	-----	4081617 4217821 ED4,ED5,ES1,ES3,HHQ4,HX,HXQ4,LH,LHE4,LJ,LJG,LKS,LP,LSS5,LSX,LT,LX,LXQ4,L1,PX,QD,QE,QH,QHP1,QHQ4,QMH,QP,QX,QXC,QXE,QXE4,QXQ4,QXU,Q1, RD,RHQ4,RJ,RSS1,RX,RXQ4,R1,SD,SDB3,SE,SJ,SJC1,SJC5,SJG,SMS,SNR,STP,STQ,SX,SXE4,SXQ4,SXU,S1,VH,VSB1,VX,VXB,VXE,VXEB,VXQ4,VXU,VXU1,WJ,WKT4,W1
			1	-	-	-----	4081617 LNZ,VMX
			1	-	-	-----	4217821 LJS,WKD6
	87135-ZE2-010	LABEL, E-SPEC (EPA STANDARD) (15.5X60.0)	1	1	-	-----	4217822 ED4,ED5,ES1,ES3,HHQ4,HX,HXQ4,LH,LHE4,LJ,LJG,LJS,LKS,LP,LSS5,LSX,LT,LX,LXQ4,L1,PX,QD,QE,QH,QHP1,QHQ4,QMH,QP,QX,QXC,QXE,QXE4,QXQ4,QXU,Q1, RD,RHQ4,RJ,RSS1,RX,RXQ4,R1,SD,SDB3,SE,SJ,SJC1,SJC5,SJG,SMS,SNR,STP,STQ,SX,SXE4,SXQ4,SXU,S1,VH,VSB1,VX,VXB,VXE,VXEB,VXQ4,VXU,VXU1,WJ,WKD6,WKT4,W1
			1	-	-	-----	-----
			1	1	-	-----	4785310 ED4/A,ED5/A,ES1/A,ES3/A,HX/A,LH/A,LJ/A,LJG/A,LJS/A,LKS/A,LP/A,LSS5/A,LSX/A,LT/A,LX/A,LXF,L1/A,PX/A,QD/A,QH/A,QHP1/A,QMH/A,QP/A,QX/A,QXC/A,QXE/A,QXU/A,Q1/A, RD/A,RJ/A,RSS1/A,RX/A,R1/A,SD/A,SDB3/A,SHW/A,SJ/A,SJC1/A,SJC5/A,SJG/A,SMS/A,SNR/A,STP/A,STQ/A,SX/A,SXU/A,S1/A,VH/A,VSB1/A,VS3,VX/A,VXB/A,VXE/A,VXEB/A,VXU/A,VXU1/A,WJ/A,W1/A
			1	-	-	-----	4660733 HHQ4/A,HXQ4/A,LHE4/A,LXQ4/A,QE/A,QHQ4/A,QXB7/A,QXE4/A,QXQ4/A,RHQ4/A,RXQ4/A,SE/A,SXE4/A,SXQ4/A,VXB7/A,VXQ4/A,VXQ7/A,WKT4/A
			1	-	-	-----	4664311 WKD6/A
32	87114-ZH7-000	LABEL, WARNING (NOT CERTIFIED FOR SALE)	1	1	-	-----	4715686 HX/A,LJ/A,LJG/A,LJS/A,LKS/A,LP/A,LSS5/A,LSX/A,LT/A,LX/A,LXF,L1/A,PX/A,QD/A,QHP1/A,QMH/A,QP/A,QT/A,QX/A,QXC/A,QXE/A,Q1/A, RD/A,RJ/A,RSS1/A,RX/A,R1/A,SD/A,SDB3/A,SHW/A,SJ/A,SJC5/A,SJG/A,SMS/A,SNR/A,SX/A,S1/A,VSB1/A,VX/A,VXE/A,WJ/A,W1/A
			1	-	-	-----	-----
			1	-	-	-----	4771380 EDT3,ES2,VS4,WMK
			1	-	-	-----	VS3
			1	-	-	-----	4776454 EDS1/A,EDT1/A,ED4/A,ED5/A,ES1/A,ES3/A,LH/A,QH/A,SJC1/A,STP/A
							STQ/A,VH/A,VXB/A,VXEB/A,VXU/A
33	87516-Z0D-800	MARK, OPERATOR CAUTION	1	-	-	-----	ES2



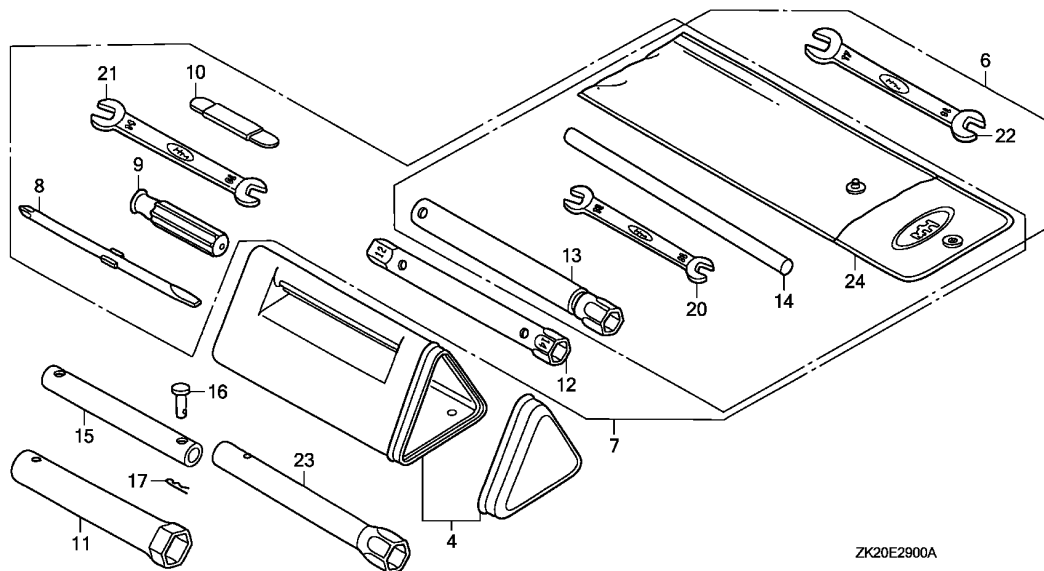

ZK20E2900A

Ref. No.	L.O.N.	(Relative ref. Number)	Description	F.R.T.
----------	--------	------------------------	-------------	--------

NO INFORMATION

Ref. No.	Part No.	Description	Reqd. QTY			Serial No.	Parts catalogue code
			(1)	(2)	(3)		
4	83501-ZF1-000	BOX, TOOL	1	-	-	-	LDB3,LHZ,LT,LT/A,LW,QDA,QHZ,QT,QT/A,SDB3,SDB3/A,SW,SWE, VSB1/VSB1/A
6	89000-ZE1-000	TOOL KIT	1	-	-	3567209	LP,QP
			1	-	-	3567210	EDN,LP/A,QHP1,QHP1/A,QMH,QMH/A,QP/A,VMX
			1	-	-	3656815	LP,QP
			-	(1)	-	-	EDN2
7	89001-ZF1-000	BAG SET, TOOL	1	-	-	-	LDB3,LHZ,LT,LT/A,LW,QDA,QHZ,QT,QT/A,SDB3,SDB3/A,SW,SWE, VSB1/VSB1/A
			1	-	-	3567209	LP,QP
8	89102-538-000	DRIVER, SCREW (NO.2 + -)	1	-	-	-	LDB3,LHZ,LT,LT/A,LW,QDA,QHZ,QT,QT/A,SDB3,SDB3/A,SW,SWE, VSB1/VSB1/A
			1	-	-	3567209	LP,QP
9	89103-538-000	GRIP	1	-	-	-	LDB3,LHZ,LT,LT/A,LW,QDA,QHZ,QT,QT/A,SDB3,SDB3/A,SW,SWE, VSB1/VSB1/A
			1	-	-	3567209	LP,QP
10	89210-ZF1-000	GAUGE ASSY., THICKNESS	1	-	-	-	LDB3,LHZ,LT,LT/A,LW,QDA,QHZ,QT,QT/A,SDB3,SDB3/A,SW,SWE, VSB1/VSB1/A
			1	-	-	3567209	LP,QP
11	89216-ZB4-000	WRENCH, PLUG	1	-	-	-	EDS,EDS1,EDS1/A,EDS2,EDS2/A,EDS6,EDS6/A,EDT1,EDT1/A,EDT2,EDT3
							EDT6,EDT6/A,ED2,ED2/A,EN2,EN2/A,ES3,ES3/A,VS3,VS4,VTE2
12	89216-ZF1-000	WRENCH, BOX	1	-	-	-	LDB3,LHZ,LT,LT/A,LW,QDA,QHZ,QT,QT/A,SDB3,SDB3/A,SW,SWE, VSB1/VSB1/A
			1	-	-	3567209	LP,QP

Ref. No.	Part No.	Description	Reqd. QTY			Serial No.	Parts catalogue code
			(1)	(2)	(3)		
13	89218-ZE1-000	WRENCH COMP., SPARK PLUG	1	-	-		EDN,EDN2,EDN2/A,ED3,ED4,ED4/A,ED5,ED5/A,EN,ES,ES1,ES1/A,ES2,ET ETS,ETX,HA,HAQ,LDB3,LHZ,LJ,LJ/A,LJG,LJG/A,LJG1,LJS,LJS/A,LK,LKS LKS/A,LM9,LNJ,LNZ,LP,LP/A,LSS4,LSS5,LSS5/A,LSX,LSX/A,LT,LT/A,LW LXF,PA,QA,QAE,QAG,QAG/A,QAQ,QDA,QHP1,QHP1/A,QHZ,QMH,QMH/A,QMX2,QP QP/A,QT,QT/A,QTC2,QTC2/A,RA,RJ,RJ/A,RSS1,RSS1/A,RTB2,RTB2/A,SDB3 SDB3/A,SJ,SJ/A,SJC,SJC1,SJC1/A,SJC5,SJC5/A,SJG,SJG/A,SK,SMX2 SMX2/A,SNC1,SNR,SNR/A,STP,STP/A,STQ,STQ/A,SW,SWE,VA,VMX,VNG,VS VSB1/A,VTA,WJ,WJ/A,WKA,WKD6,WKD6/A,WKT2,WKT2/A,WKT4,WKT4/A,W HA2,HA2/A,PAE,PA2,PA2/A,QAB2,QAB2/A,QAE2,QAE2/A,QAG2,QAG2/A,QAQ4 QAR2,QAR2/A,QA2,QA2/A,QC12,QC12/A,QE,QE/A,QKA2,QW24,RA2,RA2/A RSC2,SE,SE/A,VA2,VA2/A,VDG2,VDG2/A,VTA2,VTA2/A,VWC2,VWC2/A
	89216-809-000	1	(1)	-		SJP,SMS,SMS/A
14	89219-805-000	HANDLE, BOX WRENCH	1	-	-		EDN,LDB3,LHZ,LP,LP/A,LT,LT/A,LW,QDA,QHP1,QHP1/A,QHZ,QMH,QMH/A,QP QP/A,QT,QT/A,SDB3,SDB3/A,SW,SWE,VMX,VS1,VS1/A
			1	-	-	3656815	EDN2
			-	(1)	-		
15	89220-ZE2-000	PIPE, BOX WRENCH EXTENSION ..	-	(1)	-		L1,L1/A,P1,Q1,Q1/A,R1,R1/A,V1,W1,W1/A
16	90755-758-L00	PIN, ROLLER ARM, 8X22	-	(1)	-		L1,L1/A,P1,Q1,Q1/A,R1,R1/A,V1,W1,W1/A
17	94252-08000	PIN, LOCK, 8MM	-	(1)	-		L1,L1/A,P1,Q1,Q1/A,R1,R1/A,V1,W1,W1/A
20	99001-10120	SPANNER, 10X12	1	-	-		EDN,LDB3,LHZ,LP,LP/A,LT,LT/A,LW,QDA,QHP1,QHP1/A,QHZ,QMH,QMH/A,QP QP/A,QT,QT/A,SDB3,SDB3/A,SW,SWE,VMX,VS1,VS1/A
			1	-	-	3656815	EDN2
			-	(1)	-		
21	99001-10140	SPANNER, 10X14	1	-	-		LDB3,LHZ,LT,LT/A,LW,QDA,QHZ,QT,QT/A,SDB3,SDB3/A,SW,SWE,VS1 VSB1/A
			1	-	-	3567209	LP,QP
22	99001-14170	SPANNER, 14X17	1	-	-		EDN,LP/A,QHP1,QHP1/A,QMH,QMH/A,QP/A,VMX
			1	-	-	3567210	LP,QP
			1	-	-	3656815	EDN2
			-	(1)	-		
23	99004-21003	WRENCH, BOX (P21)	-	(1)	-		
24	99008-02300	BAG, TOOL, 230MM	1	-	-		EDN,LDB3,LHZ,LP,LP/A,LT,LT/A,LW,QDA,QHP1,QHP1/A,QHZ,QMH,QMH/A,QP QP/A,QT,QT/A,SDB3,SDB3/A,SW,SWE,VMX,VS1,VS1/A
			1	-	-	3656815	EDN2
			-	(1)	-		



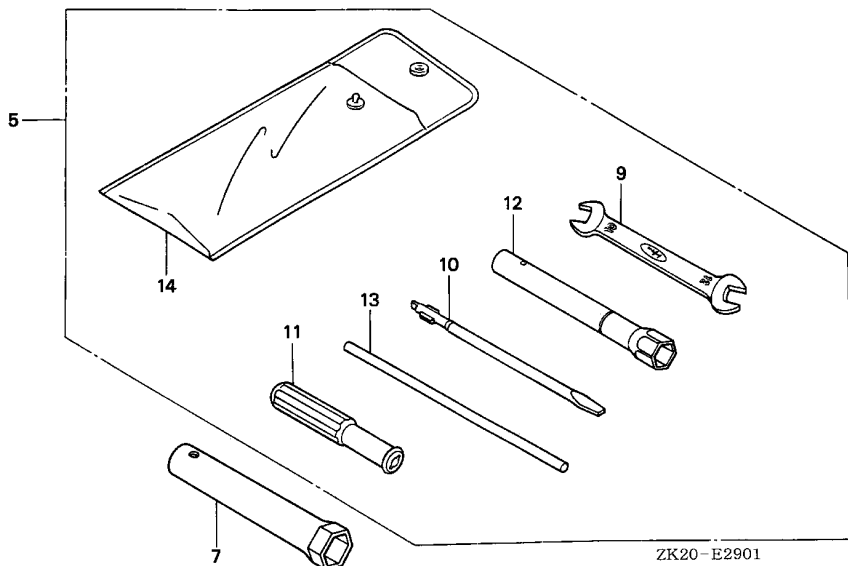

Ref. No.	L.O.N.	(Relative ref. Number)	Description	F.R.T.
----------	--------	------------------------	-------------	--------

NO INFORMATION

Ref. No.	Part No.	Description	Reqd. QTY			Serial No.	Parts catalogue code
			GX240K1				
			(1)	(2)	(3)		
5	89000-ZB6-000	TOOL KIT	1	-	-	-----	EDS5
7	89216-ZB4-000	WRENCH, PLUG	1	-	-	-----	EDS3
9	99001-10120	SPANNER, 10X12	1	-	-	-----	EDS5
10	99003-30000	DRIVER MINUS SCREW 3,(NO.2) ..	1	-	-	-----	EDS5
11	99003-50000	GRIP, SCREW DRIVER	1	-	-	-----	EDS5
12	99004-21003	WRENCH, BOX (P21)	1	-	-	-----	EDS5
13	99005-01000	BAR A, HANDLE	1	-	-	-----	EDS5
14	99008-02000	BAG, TOOL, 200MM	1	-	-	-----	EDS5

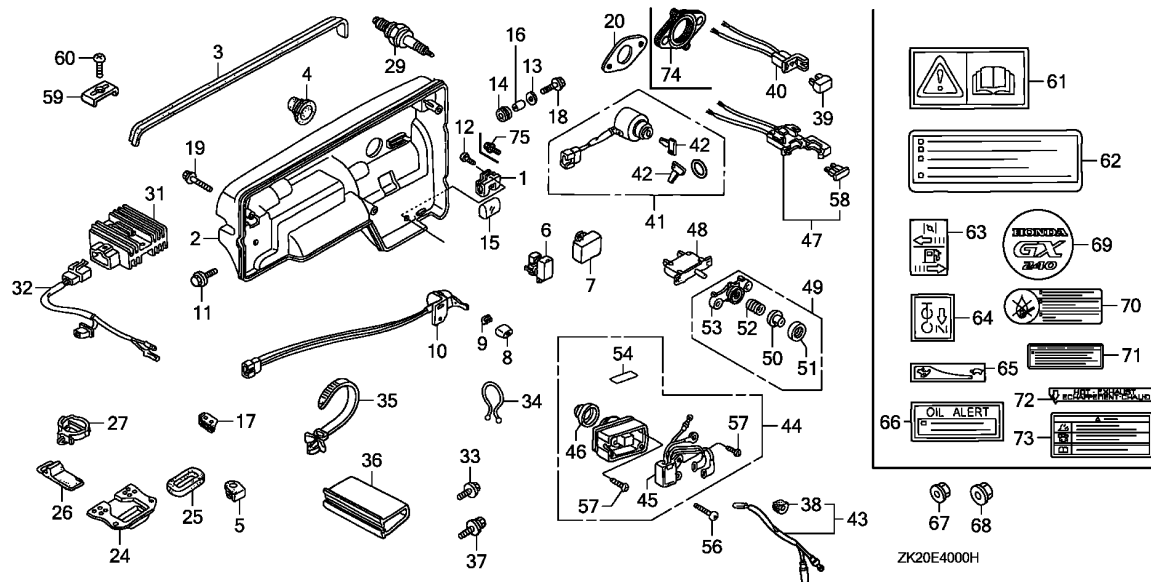

Ref. L.O.N. (Relative ref. Number) F.R.T.
No. Description

NO INFORMATION

Ref. No.	Part No.	Description	Reqd. QTY			Serial No.	Parts catalogue code
			(1)	(2)	(3)		
1	30561-ZB4-000	CLIP, WIRE	1	-	-	-----	EDS,EDS1,EDS1/A,EDS2,EDS2/A,EDS3,EDS6,EDS6/A,EDT1,EDT1/A,EDT2,EDT3,EDT6,EDT6/A,ED2,ED2/A,VTE2
2	31425-ZB4-010ZA	CASE, CONTROL *R8*.....BRIGHT RED	1	-	-	-----	EDS
3	31462-ZB4-000	RUBBER, CONTROL	1	-	-	-----	ED2
4	31482-ZB4-003	GROMMET, MAIN CORD	1	-	-	-----	EDS
5	31483-ZB4-003	GROMMET, SWITCH CORD	1	-	-	-----	ED2
6	31710-ZB4-003	DIODE ASSY.	1	-	-	-----	EDS3
7	31710-ZB7-A01	DIODE ASSY.	1	-	-	-----	EDS5
8	32343-892-003	KNOB, COCK LEVER	1	-	-	-----	EDT1,EDT1/A,EDT2,EDT3,EDT6,EDT6/A
9	36106-892-003	BUSH, CONTROL KNOB	1	-	-	-----	ED2
10	36110-ZB4-701	SWITCH ASSY., ENGINE KILL ...	1	-	-	-----	EDT1,EDT1/A,EDT2,EDT3,EDT6,EDT6/A
	36110-ZB4-702	1	-	-	-----	ED2
			1	-	-	-----	EDT1/A
			1	-	-	4857592	EDT3
			1	-	-	4857593	EDT1/A
11	95801-08020-18	BOLT, FLANGE, 8X20	1	-	-	-----	ED2/A,VTE2
12	90101-692-000	SCREW, GLOVE BOX	1	-	-	3351282	ED2
			1	-	-	-----	EDS,EDS1,EDS1/A,EDS2,EDS2/A,EDS3,EDS6,EDS6/A,EDT1,EDT1/A,EDT2,EDT3,EDT6,EDT6/A
			1	-	-	3132286	3351281
							ED2



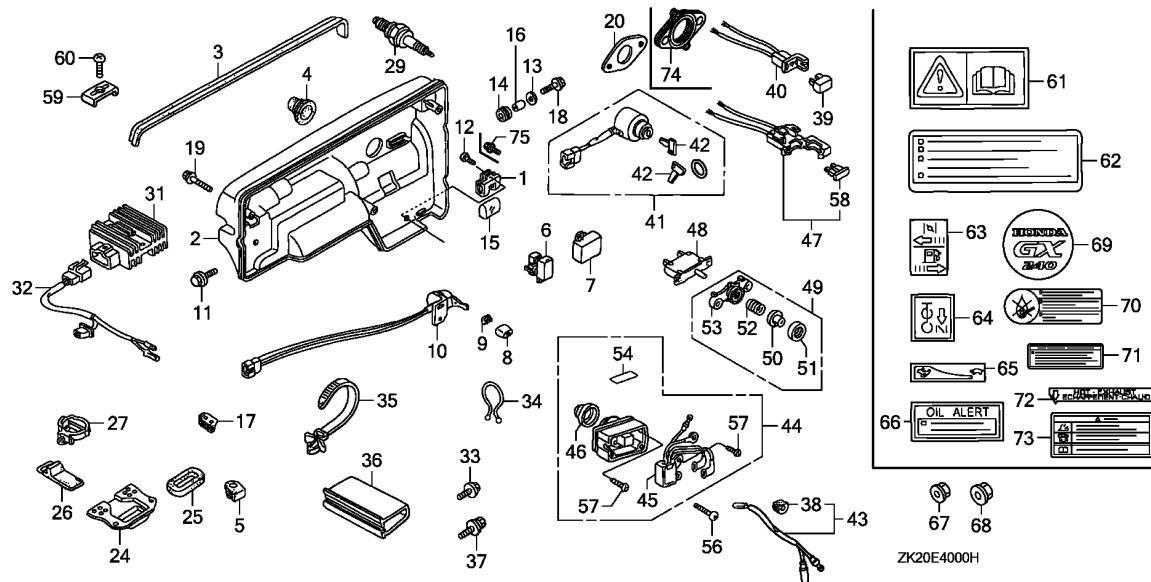

ZK20E4000H

Ref. No.	Part No.	Description	Reqd. QTY			Serial No.	Parts catalogue code
			(1)	(2)	(3)		
			GX240K1				
13	90506-500-000	WASHER, AIR DUCT	3	-	-	-----	EDS
14	90852-898-000	RUBBER, CONTROL BOX	3	-	-	-----	ED2
15	91406-ZB4-000	TUBE, CORD	3	-	-	-----	EDS
16	91552-898-000	COLLAR, CONTROL BOX	1	-	-	-----	ED2
17	91601-ZB4-003	GROMMET, TUBE	3	-	-	-----	EDS
18	95701-06018-00	BOLT, FLANGE, 6X18	1	-	-	-----	ED2
19	95701-06020-00	BOLT, FLANGE, 6X20	3	-	-	-----	EDS
19	95701-06040-08	BOLT, FLANGE, 6X40	3	-	-	-----	EDS
20	18333-ZE3-800	GASKET, EX. PIPE	3	-	-	3132286	ED2
24	68310-ZB7-000	GUIDE, UNDER AIR	1	-	-	-----	EDS5
25	68312-ZB7-000	SEAL, UNDER AIR GUIDE	1	-	-	-----	EDS5
26	89011-192-700	BAND, TOOL SETTING	1	-	-	-----	EDS5
27	90690-SA0-003	STRAP, WIRE HARNESS, 25MM (BLACK)	2	-	-	-----	EDS5
29	98079-55846	PLUG, SPARK (BPR5ES)(NGK) ...	1	-	-	-----	VS4
	98079-56841	PLUG, SPARK (BP6ES)(NGK)	1	-	-	-----	ES2
	98079-56855	PLUG, SPARK (W20EPR-U)(DENS0)	1	-	-	-----	ED2,ES,ES3,LHZ,LSS4,QHP1,QHZ
31	31600-ZE2-861	RECTIFIER ASSY., REGULATOR (10A)	1	-	-	-----	LSS5,LSS5/A
32	32110-ZE2-860	HARNESS ASSY., SUB WIRE	1	-	-	-----	LSS5,LSS5/A
33	90013-883-000	BOLT, FLANGE, 6X12(CT200) ...	2	-	-	-----	LSS5,LSS5/A



Ref. No.	Part No.	Description	Reqd. QTY			Serial No.	Parts catalogue code
			(1)	(2)	(3)		
34	90630-751-000	CLIP, PURSE LOCK	1	-	-	-----	LSS5,LSS5/A
35	90672-SA0-003	STRAP, CABLE, 118MM(BLACK) ..	1	-	-	-----	LSS5,LSS5/A
36	91406-ZE2-003	TUBE, FASTENER, 30MM	1	-	-	-----	LSS5,LSS5/A
37	95701-06025-00	BOLT, FLANGE, 6X25	2	-	-	-----	LSS5,LSS5/A
38	15521-ZA8-000	GROMMET, CORD	1	-	-	-----	LM9
39	31700-124-008	RECTIFIER ASSY., SILICON (SHINDENGEN)	1	-	-	-----	EDS,EDS1,EDS1/A,EDS2,EDS2/A,EDS6,EDS6/A
40	32130-ZE1-000	COUPLER COMP.	1	-	-	-----	EDS,EDS1,EDS1/A,EDS2,EDS2/A,EDS6,EDS6/A
41	35100-ZA0-013	SWITCH ASSY., COMBINATION ...	1	-	-	-----	EDS5
	35100-ZB4-013	1	-	-	-----	EDS,EDS1,EDS1/A,EDS2,EDS2/A,EDS3,EDS6,EDS6/A
42	35111-880-003	KEY COMP.	2	-	-	-----	EDS,EDS1,EDS2,EDS6
			2	-	-	4593890	EDS1/A,EDS2/A,EDS6/A
			2	-	-	4604960	EDS3
	35111-880-013	2	-	-	4593891	EDS1/A,EDS2/A,EDS6/A
			2	-	-	4604961	EDS3
43	35112-ZE2-U50	CORD, ENGINE KILL SWITCH (MAMETORA)	1	-	-	-----	LM9
44	35120-734-A21	SWITCH ASSY., ONE PUSH KILL .	1	-	-	-----	LM9
45	35140-734-971	KILL UNIT, ENGINE	1	-	-	-----	LM9
46	35146-734-A21	CAP, ENGINE KILL SWITCH	1	-	-	-----	LM9
47	38220-ZE1-000	CASE COMP., FUSE	1	-	-	-----	EDS,EDS1,EDS1/A,EDS2,EDS2/A,EDS6,EDS6/A
	38220-ZE2-R70	1	-	-	-----	EDS3
48	38240-VA3-900	PROTECTOR, CIRCUIT (1.0A) ...	1	-	-	-----	EDS,EDS1,EDS1/A,EDS2,EDS2/A,EDS3,EDS5,EDS6,EDS6/A
49	38250-898-000	LENS ASSY., PROTECTOR	1	-	-	-----	EDS,EDS1,EDS1/A,EDS2,EDS2/A,EDS3,EDS5,EDS6,EDS6/A
50	38251-898-000	LENS	1	-	-	-----	EDS,EDS1,EDS1/A,EDS2,EDS2/A,EDS3,EDS5,EDS6,EDS6/A
51	38252-898-000	CAP, LENS	1	-	-	-----	EDS,EDS1,EDS1/A,EDS2,EDS2/A,EDS3,EDS5,EDS6,EDS6/A
52	38253-898-000	SPRING, COIL	1	-	-	-----	EDS,EDS1,EDS1/A,EDS2,EDS2/A,EDS3,EDS5,EDS6,EDS6/A
53	38254-898-000	HOLDER, LENS	1	-	-	-----	EDS,EDS1,EDS1/A,EDS2,EDS2/A,EDS3,EDS5,EDS6,EDS6/A
54	87504-734-800	MARK, ENGINE KILL SWITCH	1	-	-	-----	LM9
56	93500-05016-0A	SCREW, PAN, 5X16	3	-	-	3077714	LM9
57	93901-22320	SCREW, TAPPING, 3X12	3	-	-	-----	LM9
58	98200-30500	FUSE, BLADE (5A)	1	-	-	-----	EDS,EDS1,EDS1/A,EDS2,EDS2/A,EDS6,EDS6/A
	98200-31000	FUSE, BLADE (10A)	1	-	-	-----	EDS3
59	16576-891-000	HOLDER, CABLE	2	-	-	-----	RSS1,RSS1/A
60	93500-05016-0A	SCREW, PAN, 5X16	1	-	-	-----	RSS1,RSS1/A
61	87522-ZH8-W41	MARK, CAUTION (PICTOGRAPH) ..	1	-	-	-----	VMT2
			1	-	-	4734392	HA2/A,PA2/A,RA2/A,VWC2/A
62	87522-ZH9-010	LABEL, CAUTION (ENGLISH, ETC.)	1	-	-	-----	QW24,VMT2,VWC2/A
63	87528-ZE2-810	MARK, CHOKE (ORANGE)	1	-	-	-----	QW24
	87528-ZF6-W40	MARK, CHOKE (BLACK)	1	-	-	-----	QW24
64	87528-898-620	MARK, CHOKE	1	-	-	-----	EDT3,VMT2,VS4
65	87532-ZH8-W40	MARK, THROTTLE INDICATION ...	1	-	-	-----	VMT2
66	87532-ZH8-810	MARK, OIL ALERT (EXTERNAL) ..	1	-	-	-----	QW24,VMT2,VWC2/A
67	94050-06000	NUT, FLANGE, 6MM	1	-	-	-----	VMT2
68	94050-08000	NUT, FLANGE, 8MM	1	-	-	-----	VMT2
69	87521-ZE2-W04	EMBLEM (GX240)	1	-	-	-----	VS4
70	87522-883-660	MARK, CAUTION (ENGLISH/FRENCH/SPANISH)	1	-	-	-----	EDT3
71	87533-ZC0-630	MARK, AIR CLEANER	1	-	-	-----	EDT3,VS4
72	87539-898-620	MARK, EX. CAUTION (ENGLISH/FRENCH)	1	-	-	-----	EDT3,VS4

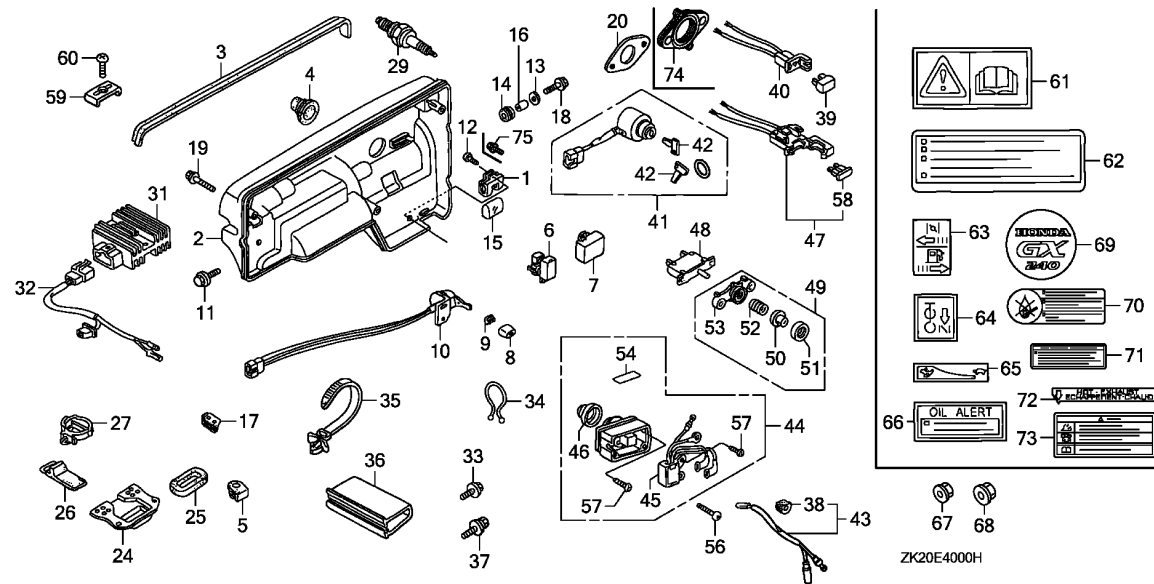

ZK20E4000H

2

Ref. No.	Part No.	Description	Reqd. QTY			Serial No.	Parts catalogue code
			(1)	(2)	(3)		
			GX240K1				
73	87516-Z0D-800	MARK, OPERATOR CAUTION	1	-	-	-----	EDT3,VS4
74	18333-ZF6-W01	GASKET, EX. PIPE	1	-	-	-----	VMT2
75	90013-883-000	BOLT, FLANGE, 6X12(CT200) ...	1	-	-	-----	ED2/A,VTE2
			1	-	-	3351282	ED2

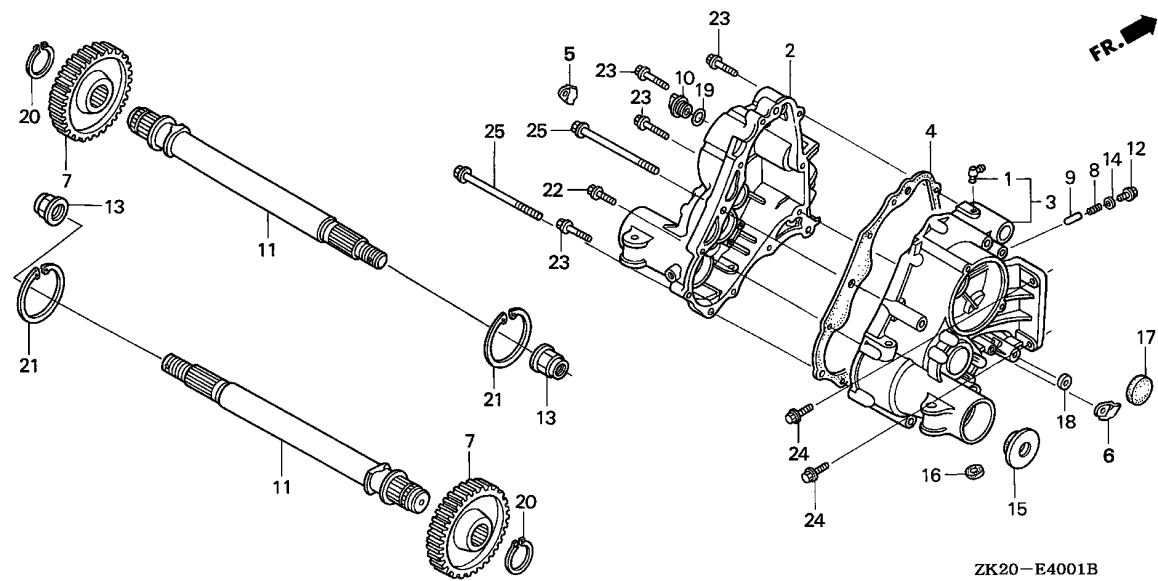

Ref. No. L.O.N. (Relative ref. Number) Description F.R.T.

NO INFORMATION

Ref. No.	Part No.	Description	Reqd. QTY			Serial No.	Parts catalogue code
			(1)	(2)	(3)		
1	11106-GM2-300	JOINT, BREATHER	1	-	-	SHW,SHW/A	
2	21111-766-000	CASE, R. TRANSMISSION	1	-	-	SHW,SHW/A	
3	21210-766-000	CASE COMP., L. TRANSMISSION ..	1	-	-	SHW,SHW/A	
4	21281-740-020	PACKING, TRANSMISSION CASE ..	1	-	-	SHW,SHW/A	
5	21913-740-000	PLATE, R. SIDE CLUTCH	1	-	-	SHW,SHW/A	
6	21914-740-000	PLATE, L. SIDE CLUTCH	1	-	-	SHW,SHW/A	
7	23581-740-000	GEAR, FINAL (35T)	2	-	-	SHW,SHW/A	
8	24271-765-000	SPRING, BALL SETTING	1	-	-	SHW,SHW/A	
9	24481-766-000	PIECE, INTERLOCK	1	-	-	SHW,SHW/A	
10	25611-733-000	CAP, OIL	1	-	-	SHW,SHW/A	
11	42311-797-B00	SHAFT, WHEEL	2	-	-	SHW,SHW/A	
12	90111-727-000	BOLT, FLANGE, 8X16	1	-	-	SHW,SHW/A	
13	90305-HA7-670	NUT, AXLE, 16MM	2	-	-	SHW,SHW/A	
14	90429-PD1-000	WASHER, SEALING, 8MM	1	-	-	SHW,SHW/A	
15	91206-733-024	WATER SEAL, 25X52X9.5(NOK) ..	2	-	-	SHW,SHW/A	
16	91251-740-003	OIL SEAL (12X18X4.2)	2	-	-	SHW,SHW/A	
17	91251-766-003	PLUG, SEAL, 31X5	1	-	-	SHW,SHW/A	
18	91272-733-931	OIL SEAL, 15X28X7	1	-	-	SHW,SHW/A	
19	91303-800-000	O-RING, 16MM	1	-	-	SHW,SHW/A	
20	94510-25000	CIRCLIP, EXTERNAL, 25MM	2	-	-	SHW,SHW/A	
21	94520-52000	CIRCLIP, INTERNAL, 52MM	2	-	-	SHW,SHW/A	
22	95701-06032-00	BOLT, FLANGE, 6X32	5	-	-	SHW,SHW/A	
23	95701-06040-00	BOLT, FLANGE, 6X40	4	-	-	SHW,SHW/A	
24	95701-08030-00	BOLT, FLANGE, 8X30	4	-	-	SHW,SHW/A	
25	95701-10115-00	BOLT, FLANGE, 10X115	2	-	-	SHW,SHW/A	



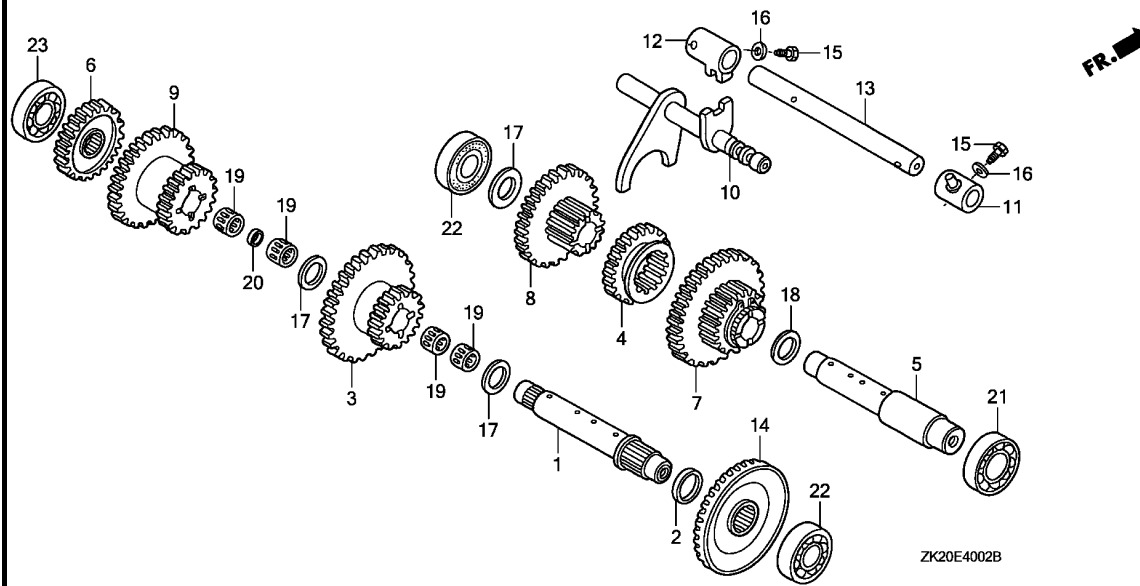

Ref. No.	L.O.N.	(Relative ref. Number) Description	F.R.T.
NO INFORMATION			

Ref. No.	Part No.	Description	Reqd. QTY			Serial No.	Parts catalogue code
			(1)	(2)	(3)		
1	23111-766-000	SHAFT, INPUT	1	-	-	-----	SHW,SHW/A
2	23114-766-000	COLLAR, INPUT SHAFT	1	-	-	-----	SHW,SHW/A
3	23341-766-000	GEAR, COUNTER (19T/40T)	1	-	-	-----	SHW,SHW/A
4	23367-766-000	GEAR, HIGH & LOW CHANGE (26T)	1	-	-	-----	SHW,SHW/A
5	23377-766-000	SHAFT, AUXILIARY	1	-	-	-----	SHW,SHW/A
6	23421-797-A00	GEAR, DRIVE (29T)	1	-	-	-----	SHW,SHW/A
7	23425-766-000	GEAR COMP., HIGH & LOW DRIVE (21T/40T)	1	-	-	-----	SHW,SHW/A
8	23431-797-A00	GEAR, DRIVEN (32T)	1	-	-	-----	SHW,SHW/A
9	23446-766-000	GEAR, LOW IDLE (21T/35T)	1	-	-	-----	SHW,SHW/A
10	24110-766-000	SHAFT COMP., SHIFT FORK	1	-	-	-----	SHW,SHW/A
11	24122-766-000	SLIDER, SHIFT	1	-	-	-----	SHW,SHW/A
12	24126-766-000	ARM, SELECT FORK	1	-	-	-----	SHW,SHW/A
13	24611-766-000	SHAFT, SHIFT	1	-	-	-----	SHW,SHW/A
14	41141-740-000	GEAR, DRIVEN BEVEL (25T)	1	-	-	-----	SHW,SHW/A
15	90029-611-010	BOLT, HEX., 8X24	2	-	-	-----	SHW,SHW/A
16	90412-679-000	WASHER, CONICAL SPRING, 8MM	2	-	-	-----	SHW,SHW/A
17	90453-360-000	WASHER, THRUST, 20MM	3	-	-	-----	SHW,SHW/A
18	90454-KF0-000	WASHER, THRUST, 17MM	1	-	-	-----	SHW,SHW/A
19	91051-727-000	BEARING, NEEDLE, 20X24X17	4	-	-	-----	SHW,SHW/A
20	91555-766-000	COLLAR, LOW IDLE GEAR	1	-	-	-----	SHW,SHW/A
21	96100-60040-00	BEARING, RADIAL BALL, 6004	1	-	-	-----	SHW,SHW/A
22	96100-62030-00	BEARING, RADIAL BALL, 6203	2	-	-	-----	SHW,SHW/A
23	96140-62030-00	BEARING, RADIAL BALL, 6203U	1	-	-	-----	SHW,SHW/A

E-40-3

SIDE CLUTCH

2-F 8

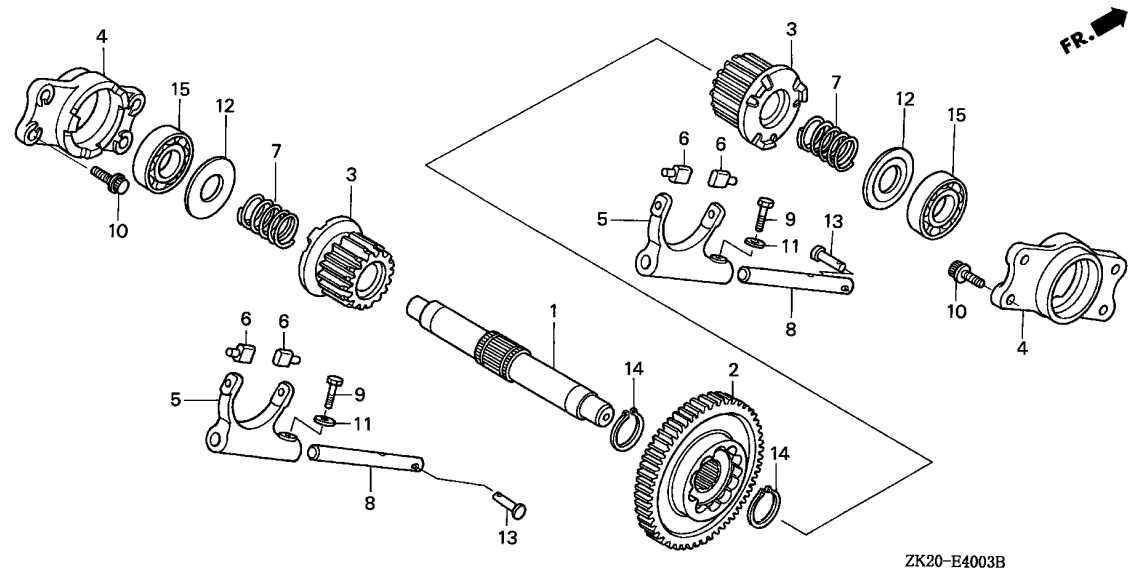

ZK20-E4003B

Ref. No.	L.O.N.	(Relative ref. Number)	Description	F.R.T.
----------	--------	------------------------	-------------	--------

NO INFORMATION

Ref. No.	Part No.	Description	Reqd. QTY			Serial No.	Parts catalogue code
			(1)	(2)	(3)		
1	23231-740-000	SHAFT, SIDE CLUTCH	1	-	-	-----	SHW,SHW/A
2	23407-766-000	GEAR, SIDE CLUTCH DRIVE (49T)	1	-	-	-----	SHW,SHW/A
3	23511-740-000	GEAR, SIDE CLUTCH (16T)	2	-	-	-----	SHW,SHW/A
4	23521-797-A00	CASE, SIDE CLUTCH BEARING ...	2	-	-	-----	SHW,SHW/A
5	40111-740-000	FORK, SIDE CLUTCH	2	-	-	-----	SHW,SHW/A
6	40112-740-003	PIN, FORK	4	-	-	-----	SHW,SHW/A
7	40181-776-000	SPRING, SIDE CLUTCH	2	-	-	-----	SHW,SHW/A
8	40331-740-000	SHAFT, SIDE CLUTCH ARM	2	-	-	-----	SHW,SHW/A
9	90028-634-000	BOLT, SPECIAL, 6X21	2	-	-	-----	SHW,SHW/A
10	90030-PC8-000	BOLT, SPECIAL, 8MM	8	-	-	-----	SHW,SHW/A
11	90411-744-000	WASHER, CONICAL SPRING, 6MM ..	2	-	-	-----	SHW,SHW/A
12	90501-740-010	WASHER, CLUTCH SPRING	2	-	-	-----	SHW,SHW/A
13	90752-735-000	PIN, AUXILIARY CHANGE LEVER ..	2	-	-	-----	SHW,SHW/A
14	94510-25000	CIRCLIP, EXTERNAL, 25MM	2	-	-	-----	SHW,SHW/A
15	96100-62030-00	BEARING, RADIAL BALL, 6203 ...	2	-	-	-----	SHW,SHW/A

2

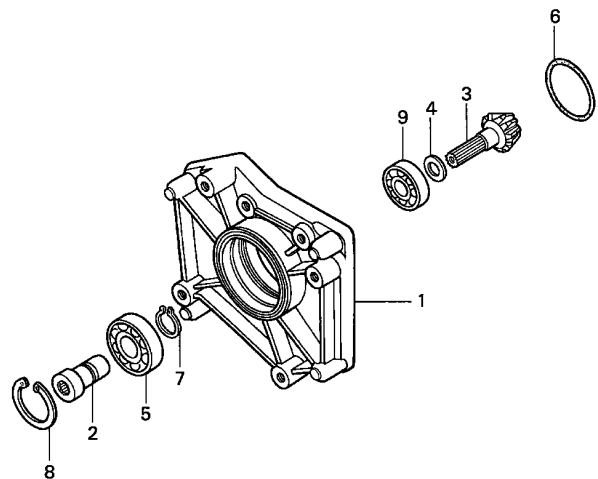

Ref. (Relative ref. Number)
No. L.O.N. Description F.R.T.

NO INFORMATION

Ref. No.	Part No.	Description	Reqd. QTY			Serial No.	Parts catalogue code
			(1)	(2)	(3)		
1	21171-766-000	COVER, BEVEL	1	-	-	-----	SHW,SHW/A
2	23218-766-000	SHAFT, JOINT	1	-	-	-----	SHW,SHW/A
3	41131-766-000	PINION, BEVEL	1	-	-	-----	SHW,SHW/A
4	90540-740-000	WASHER, BEVEL GEAR	1	-	-	-----	SHW,SHW/A
5	91001-878-003	BEARING, RADIAL BALL, 62/22 ..	1	-	-	-----	SHW,SHW/A
6	91301-766-003	O-RING, 42.5X3	1	-	-	-----	SHW,SHW/A
7	94510-22000	CIRCLIP, EXTERNAL, 22MM	1	-	-	-----	SHW,SHW/A
8	94520-50000	CIRCLIP, INTERNAL, 50MM	1	-	-	-----	SHW,SHW/A
9	96100-62030-00	BEARING, RADIAL BALL, 6203 ..	1	-	-	-----	SHW,SHW/A

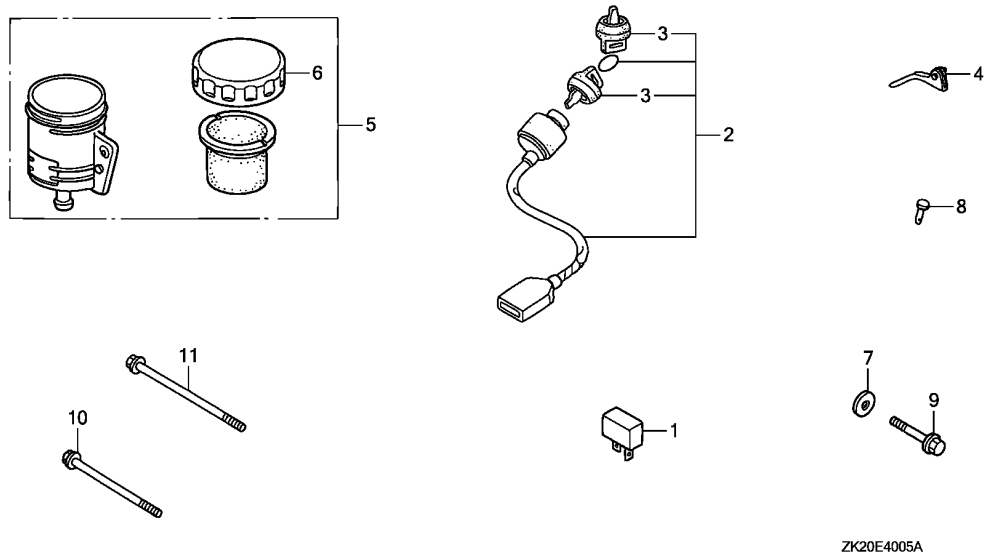

ZK20E4005A

Ref. No.	L.O.N.	(Relative ref. Number)	Description	F.R.T.
NO INFORMATION				

Ref. No.	Part No.	Description	Reqd. QTY			Serial No.	Parts catalogue code
			(1)	(2)	(3)		
1	31700-124-003	RECTIFIER ASSY., SILICON (STANLEY)	1	-	-	-----	SHW,SHW/A
2	35100-768-S01	SWITCH ASSY., COMBINATION ...	1	-	-	-----	SHW,SHW/A
3	35110-766-003	KEY ASSY., COMBINATION SWITCH	2	-	-	-----	SHW
	35110-736-612	2	-	-	4568916	SHW/A
4	54611-740-010	LEVER, SIDE CLUTCH	2	-	-	-----	SHW,SHW/A
5	56850-767-000	TANK ASSY., OIL	1	-	-	-----	SHW,SHW/A
6	56862-767-300	BODY, OIL CAP	1	-	-	-----	SHW,SHW/A
7	90534-706-010	WASHER, LOCK, 8MM	1	-	-	-----	SHW,SHW/A
8	90754-740-010	PIN, SIDE CLUTCH ARM	2	-	-	-----	SHW,SHW/A
9	92101-08025-0A	BOLT, HEX., 8X25	1	-	-	-----	SHW,SHW/A
10	95701-10125-00	BOLT, FLANGE, 10X125	1	-	-	-----	SHW,SHW/A
11	95701-10160-00	BOLT, FLANGE, 10X160	1	-	-	-----	SHW,SHW/A



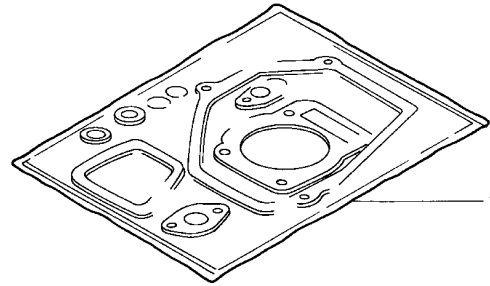

HENG-X0003

Ref. L.O.N. (Relative ref. Number) F.R.T.
No. Description

NO INFORMATION

Ref. No.	Part No.	Description	Reqd. QTY			Serial No.	Parts catalogue code
			(1)	(2)	(3)		
1	061A1-ZE2-020	GASKET KIT	1	1	-	4045100	LJ,L1,P1,Q1,RJ,R1,SJ,SNR,S1,V1,WJ,W1
	061B1-ZE2-000	1	-	-	-----	LK,SK,WKA
	061B1-ZE2-020	1	-	-	-----	SJP
	061C1-ZE2-010	1	1	-	3146326	HA,PA,QA,QAE,RA,VA,VAH1,VTA
			1	-	-	4045100	STP,STQ
			1	1	-	3146326	EDN,EDS,ED2,ED3,EN,ES,ES1,ES3,ET,ETS,ETX,HH,HX,LD,LH,LHE,LKS,LP,LW,LX,LX2,L1,PX,P1,QA,QAE,QD,QE,QH,QHC,QHE,QP,QT,QX,QXB,QXC,QXE,QXEB,Q1,RD,RH,RHE,RX,R1,SD,SE,SH,SHE,SHEZ,SW,SWE,SX,SXB,SXE,SXEB,VH,VNG,VX,VXB,VXE,VXEB,V1,WH,W1
	061C1-ZE2-020	1	-	-	-----	QDA
	061C1-ZE2-040	1	-	-	-----	LNJ
	061C1-ZE2-800	1	-	-	3146326	LM9
	06111-ZE2-R30	1	-	-	-----	QXC
			1	-	-	-----	EDT2
			1	-	-	4045100	EDS1,EDS2,EDT1
	06111-ZE2-R60	1	-	-	4045100	SMS
	06111-ZK2-V50	1	-	-	-----	QMX2
	061A1-ZE2-040	1	1	-	3146327	EDN,EDS,ED3,EN,ES,ET,ETS,ETX,HH,LD,LHE,LW,LX2,P1,QA,QAE,QHC,QHE,QXB,QXEB,RH,RHE,SH,SHE,SHEZ,SW,SWE,SXB,SXE,SXEB,VNG,V1,WH
			1	1	-	3146327	4045100 ED2,ES1,ES3,HX,LH,LKS,LP,LX,L1,PX,QD,QE,QH,QP,QT,QX,QXC,QXE,Q1,RD,RX,R1,SD,SE,SX,VH,VX,VXB,VXE,VXEB,W1
			1	-	-	-----	EDS3,EDS5,HAQ,LDB1,LDB3,QAQ,QAQ4,QKA2,RHE4,RSC2,SDB1,SNC1,SNE1
			1	-	-	4045100	EDN2,ED4,ED5,HA2,HHQ4,HXQ4,LHE4,LXQ4,LX2,PA2,PMT2,QAE2,QAG2,QAR2,QA2,QHQ4,QXC9,QXE4,QXQ4,QXU,RA2,RHQ4,RTB2,RXQ4,SDB3,SMX2,SXE4,SXQ4,SXU,VA2,VH12,VSB1,VWC2,VXQ4,VXU,VXU1,WKT2,WKT4
	061A1-ZE2-840	1	-	-	-----	SJC
			1	-	-	3210414	HTX
			1	-	-	4045100	LJG,LNZ,SJC1,SJC5,SJG
	061C1-ZE2-810	1	-	-	3146327	3486453 QXC

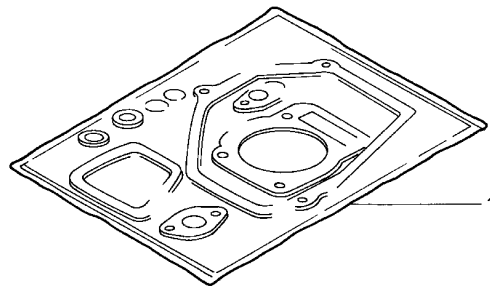

HENG-X0003

Ref. No.	Part No.	Description	Reqd. QTY			Serial No.	Parts catalogue code
			(1)	(2)	(3)		
			GX240K1				
(1)	061C1-ZE2-820	GASKET KIT	1	-	-	3146327 -----	HA,PA,QA,QAE,RA,VA,VAH1,VTA
	06111-ZE2-R31	1	-	-	-----	EDS1/A,EDS2/A,EDS6,EDS6/A,EDT1/A,EDT3,EDT6,EDT6/A
	06111-ZE2-R61	1	-	-	4045101 -----	EDS1,EDS2,EDT1
			1	-	-	-----	SMS/A
			1	-	-	4045101 -----	SMS



PART NO. INDEX

Part Number	Address	Page	Ref.	Part Number	Address	Page	Ref.	Part Number	Address	Page	Ref.	Part Number	Address	Page	Ref.
06000				11400-ZE2-020	F3	66	3	12310-ZE3-791	E2	49	6	13320-ZE2-601	G6	85	3
				11400-ZE2-030	F3	66	3	12315-ZE3-840	E5	52	17	13320-ZE2-602	G6	85	3
06111-ZE2-R30	2-F11	282	1	11400-ZE2-601	F3	66	3	12391-ZE2-020	E2	49	7	13320-ZE2-611	G6	85	4
06111-ZE2-R31	2-F12	283	1	11400-ZE2-602	F3	66	3					13320-ZE2-612	G7	86	4
06111-ZE2-R60	2-F11	282	1	11400-ZE2-603	F3	66	3	13000				13320-ZE2-651	G7	86	5
06111-ZE2-R61	2-F12	283	1	11400-ZE2-611	F15	78	3					13320-ZE2-652	G7	86	5
06111-ZK2-V50	2-F11	282	1		F16	79	3	13010-Z5F-004	H1	96	1	13320-ZE2-671	G7	86	6
061A1-ZE2-020	2-F11	282	1	11400-ZE2-612	F16	79	3	13010-ZE2-013	G9	88	1	13331-357-000	G8	87	16
061A1-ZE2-040	2-F11	282	1	11400-ZE2-613	F16	79	3	13010-ZE2-014	G9	88	1	13351-ZE2-010	G7	86	7
061A1-ZE2-840	2-F11	282	1	11400-ZE2-621	F16	79	3	13010-ZE2-921	G12	91	1				
061B1-ZE2-000	2-F11	282	1	11400-ZE2-622	F16	79	3	13010-ZE2-922	G12	91	1	14000			
061B1-ZE2-020	2-F11	282	1	11400-ZE2-623	F16	79	3	13011-Z5F-004	H1	96	1				
061C1-ZE2-010	2-F11	282	1	11400-ZE2-670	F3	66	3	13011-ZE2-013	G10	89	1	14100-ZE2-W00	H7	102	1
061C1-ZE2-020	2-F11	282	1	11400-ZE2-671	F4	67	3	13011-ZE2-014	G10	89	1	14100-ZE2-W01	H8	103	1
061C1-ZE2-040	2-F11	282	1	11500-ZE2-610	2-E5	260	1	13011-ZE2-921	G13	92	1	14100-ZH9-000	H7	102	1
061C1-ZE2-800	2-F11	282	1	11500-ZE2-620	2-E7	262	1	13011-ZE2-922	G14	93	1	14100-ZH9-010	H7	102	1
061C1-ZE2-810	2-F11	282	1	11500-ZK2-800	2-E5	260	1	13012-Z5F-004	H2	97	1	14100-ZK2-870	H8	103	1
061C1-ZE2-820	2-F12	283	1	11521-ZE2-800	2-E5	260	2	13012-ZE2-013	G10	89	1	14410-ZE2-013	H8	103	2
					2-E7	262	2	13012-ZE2-014	G10	89	1	14411-ZE2-611	2-E5	260	3
11000				12000				13012-ZE2-921	G14	93	1	14431-ZE2-000	H8	103	3
11106-GM2-300	2-F6	277	1					13012-ZE2-922	G15	94	1	14431-ZE2-010	H9	104	3
11300-ZE2-000	F2	65	3	12000-ZE2-040	E10	57	1	13013-Z5F-004	H2	97	1	14441-ZE2-000	H9	104	4
	F16	79	3	12000-ZE2-050	E10	57	1	13013-ZE2-013	G11	90	1	14451-ZE1-013	H9	104	5
11300-ZE2-010	F3	66	3	12000-ZE2-060	E11	58	1	13013-ZE2-014	G11	90	1	14568-ZE1-000	H9	104	6
	F16	79	3	12000-ZE2-405	E12	59	1	13013-ZE2-921	G16	95	1	14711-ZE2-000	H9	104	7
11300-ZE2-020	F3	66	3	12000-ZE2-406	E12	59	1	13013-ZE2-922	G16	95	1	14711-ZE2-W00	H9	104	7
	F16	79	3	12000-ZE2-407	E11	58	1	13101-ZE2-811	H6	101	7	14721-ZE2-000	H9	104	8
11300-ZE2-405	G4	83	2	12000-ZE2-408	E11	58	1	13101-ZE2-W00	H2	97	2	14721-ZE2-810	H10	105	8
11300-ZE2-406	G4	83	2	12000-ZE2-409	E11	58	1	13101-ZE2-W01	H4	99	2	14721-ZE2-W00	H10	105	8
11300-ZE2-600	F2	65	3	12000-ZE2-815	E10	57	1	13102-ZE2-811	H6	101	7	14751-ZE2-003	H10	105	9
	F16	79	3	12000-ZE2-824	E10	57	1	13102-ZE2-W00	H3	98	2	14771-ZE2-000	H10	105	10
11300-ZE2-601	F3	66	3	12000-ZE2-825	E11	58	1	13102-ZE2-W01	H5	100	2				
	F16	79	3	12000-ZE2-825	E11	58	1	13102-ZE2-811	H6	101	7	14773-ZE2-000	H10	105	11
11300-ZE2-602	F3	66	3	12000-ZE2-834	E10	57	1	13103-ZE2-811	H6	101	7	14775-ZE2-010	E2	49	8
	F16	79	3	12000-ZE2-835	E11	58	1	13103-ZE2-W00	H4	99	2	14781-ZE2-000	H10	105	12
11300-ZE2-610	F16	79	3	12000-ZE2-844	E10	57	1	13103-ZE2-W01	H5	100	2	14791-ZE2-010	H10	105	13
11300-ZE2-611	F16	79	3	12000-ZE2-845	E11	58	1	13104-ZE2-811	H6	101	7				
11300-ZE2-612	F16	79	3	12000-ZE2-854	E10	57	1	13104-ZE2-W00	H4	99	2	15000			
11300-ZE2-620	F14	77	2	12000-ZE2-855	E11	58	1	13104-ZE2-W01	H5	100	2				
	F16	79	3	12000-ZE2-864	E10	57	1	13111-ZE2-000	H5	100	3	15510-ZE2-043	E12	59	2
11300-ZE2-621	F16	79	3	12000-ZE2-865	E11	58	1	13200-ZE2-010	H5	100	4	15510-ZE2-053	E12	59	2
11300-ZE2-622	F16	79	3	12000-ZE2-866	E11	58	1	13200-ZE2-305	H6	101	4	15520-ZB2-003	I12	123	19
11300-ZE2-630	F2	65	3	12000-ZE2-874	E10	57	1	13310-ZE2-010	G6	85	2	15520-ZE2-003	I7	118	1
11300-ZE2-631	F3	66	3	12000-ZE2-875	E11	58	1	13310-ZE2-020	G6	85	2	15520-ZE2-822	2-D7	246	1
11300-ZE2-632	F3	66	3	12000-ZE2-876	E12	59	1	13310-ZE2-601	G6	85	3	15521-ZA8-000	2-F4	275	38
11300-ZE2-633	F3	66	3	12000-ZE2-Q00	E11	58	1	13310-ZE2-602	G6	85	3	15600-735-003	F4	67	5
11300-ZE2-700	G4	83	2	12000-ZE2-Q10	E11	58	1	13310-ZE2-611	G6	85	4		F13	76	23
11300-ZE2-701	G4	83	2	12200-ZH9-000	E1	48	1	13310-ZE2-612	G6	85	4		F14	77	5
11300-ZE2-E70	G4	83	2	12200-ZH9-405	E1	48	1	13310-ZE2-631	G8	87	11		F15	78	5
11300-ZE2-E71	G4	83	2	12200-ZH9-406	E1	48	1	13310-ZE2-632	G8	87	11		G1	80	6
11300-ZH9-S50	F3	66	3	12200-ZH9-800	E1	48	1	13310-ZE2-651	G7	86	5		G3	82	24
11315-ZB7-000	I13	124	1	12204-ZE2-306	E1	48	2	13310-ZE2-652	G7	86	5		G1	80	6
11381-ZE2-800	F14	77	3	12205-ZE2-305	E1	48	3	13310-ZE2-671	G7	86	6	15600-735-700	G1	80	6
	G4	83	3	12209-ZE8-003	H10	105	16	13310-ZE2-672	G7	86	6		G3	82	24
11381-ZE2-801	F2	65	2	12216-ZE2-300	E1	48	4	13310-ZE2-701	G8	87	10	15600-ZG4-003	F4	67	4
	F15	78	2	12251-ZE2-800	E1	48	5	13310-ZE2-702	G8	87	10		F13	76	22
	F16	79	2	12310-ZE2-010	E2	49	6	13310-ZK2-600	G6	85	3		F14	77	4
	G4	83	3	12310-ZE2-020	E2	49	6	13310-ZK2-670	G7	86	6		F15	78	4
	F3	66	3	12310-ZE3-790	E2	49	6	13320-ZE2-010	G6	85	2		G1	80	4
								13320-ZE2-020	G6	85	2	15620-ZE2-700	G4	83	4

PART NO. INDEX

2-G 3

Part Number	Address	Page	Ref.	Part Number	Address	Page	Ref.	Part Number	Address	Page	Ref.	Part Number	Address	Page	Ref.				
17212-ZE2-810	L5	164	2	17505-898-023	N7	198	7		N9	200	5	18325-ZE2-821	M2	177	6	18466-ZH8-W40	M9	184	25
17218-ZE2-821	L8	167	3	17505-ZB2-003	N11	202	7		N16	207	13	18325-ZE2-A00	M16	191	2		M13	188	23
17218-ZE3-000	L13	172	3		N4	211	20		2-B3	210	6	18325-ZE2-A10	M16	191	2	18522-ZE2-U50	M3	178	8
	M1	176	3	17505-ZE2-013	2-B4	195	19	17624-187-020	N7	198	12	18325-ZE2-G30	M2	177	6				
17219-ZE3-840	L13	172	4		N14	205	10	17631-329-003	N4	195	23	18325-ZE2-P30	M2	177	6				
17220-ZB4-003	L15	174	4	17507-ZA0-800	N7	198	8		N9	200	6	18325-ZE2-P50	M2	177	6				
17220-ZB7-000	L15	174	4	17510-893-000ZB	2-B3	210	4		N16	207	15	18329-ZB4-000	N1	192	4	19511-ZE2-000	2-B5	212	2
17222-ZB4-000	L15	174	5	17510-ZB4-000ZA	N11	202	8		2-B3	210	7	18330-ZB7-003	M15	190	2	19511-ZE3-000	2-B5	212	2
17222-ZB7-000	L15	174	5	17510-ZB4-000ZB	N11	202	8	17631-899-000	N7	198	13	18330-ZE2-000	M2	177	7	19512-ZE2-000	2-B5	212	3
17230-ZE2-820	L8	167	4	17510-ZB4-000ZC	N11	202	8		N12	203	10		M16	191	3	19602-ZE2-E10	I13	124	3
17230-ZE3-841	L13	172	5	17510-ZB4-000ZE	N11	202	8		2-B4	211	23	18330-ZE2-700	N1	192	5	19610-ZB7-000	I13	124	4
17231-899-000	L15	174	6	17510-ZB4-000ZF	N11	202	8	17631-Z0T-812	N6	197	41	18330-ZE2-710	N1	192	5	19610-ZE2-010ZA	I8	119	3
17231-ZB7-000	L15	174	7	17510-ZB4-000ZH	N11	202	8		N10	201	18	18330-ZE2-W00	M6	181	4	19610-ZE2-010ZC	I8	119	3
17231-ZE2-000	L3	162	3	17510-ZB6-010	N7	198	9		2-B2	209	35	18330-ZH9-N00	M11	186	4	19610-ZE2-010ZD	I8	119	3
17231-ZE2-810	L5	164	3	17510-ZB7-000	2-B4	211	21	17631-ZH7-003	N4	195	24	18331-ZE2-810	M2	177	8	19610-ZE2-010ZE	I8	119	3
17231-ZH9-820	L8	167	5	17510-ZE2-010ZA	N4	195	20		N10	201	16		M6	181	5	19610-ZE2-010ZG	I8	119	3
17231-ZH9-N00	M1	176	4		N8	199	3		2-B2	209	33		M11	186	5	19610-ZE2-010ZH	I8	119	3
17231-ZH9-N01	M1	176	4		N14	205	11		2-B3	210	7	18333-ZB4-800	N1	192	7	19610-ZE2-010ZJ	I8	119	3
17232-891-000	L8	167	6	17510-ZE2-010ZD	N8	199	3	17670-899-000	N12	203	11	18333-ZB7-800	M15	190	3	19610-ZE2-010ZK	I8	119	3
	L13	172	6		N14	205	11	17670-ZB6-000	N7	198	14	18333-ZE3-800	M3	178	9	19610-ZE2-700ZA	I8	119	3
	M1	176	5	17510-ZE2-010ZE	N14	205	11	17672-880-000	N4	195	26		M6	181	6	19610-ZE2-700ZB	I8	119	3
17233-896-701	M9	184	18	17510-ZE2-010ZF	N14	205	11		N9	200	8		M12	187	6	19610-ZE2-700ZC	I8	119	3
	M12	187	16	17510-ZE2-010ZG	N14	205	11	17672-899-000	N16	207	19		M16	191	4	19610-ZE2-700ZD	I8	119	3
17235-899-000	L15	174	8	17510-ZE2-020ZA	N4	195	20	17672-ZE2-W01	2-B3	210	9		N2	193	16	19610-ZE2-700ZE	I8	119	3
17235-ZE2-820	L8	167	7		N8	199	3		2-B4	211	12	18333-ZF6-W01	M14	189	33	19610-ZE2-700ZF	I8	119	3
17235-ZH9-N00	M1	176	6		N14	205	11		N9	200	7		N2	193	18	19610-ZE2-700ZG	I8	119	3
17236-899-000	L15	174	9	17510-ZE2-020ZD	N8	199	3		N16	207	18		2-F5	276	74	19610-ZE2-700ZH	I8	119	3
17238-ZE2-310	L3	162	4		N14	205	11		2-B3	210	8	18333-ZK6-Y00	M12	187	6	19610-ZE2-700ZI	I8	119	3
	L5	164	4	17510-ZE2-020ZE	N14	205	11	17673-893-000	N4	195	27	18336-ZE2-000	M3	178	10	19620-ZE2-000ZC	I8	119	4
	L9	168	8	17510-ZE2-020ZF	N14	205	11		N9	200	9	18338-ZE2-V60	N1	192	8	19620-ZE2-000ZD	I8	119	4
	L13	172	7	17510-ZE2-020ZG	N14	205	11		N16	207	20	18355-ZB4-630	N1	192	9	19631-ZE2-D00	I9	120	5
	M1	176	7	17510-ZE2-800ZA	N8	199	3		2-B3	210	10	18355-ZE2-010	M3	178	11	19640-ZE2-E10	I13	124	6
17239-ZE1-000	L3	162	5		N14	205	11	17682-817-020	2-B3	210	11		M6	181	7				
	L5	164	5	17510-ZE2-800ZB	N14	205	11						M12	187	7				
	L10	169	9	17510-ZE2-800ZC	N4	195	20						M12	187	7				
	M1	176	8		N8	199	3					18000	M12	187	7				
17239-ZE3-840	L13	172	8		N15	206	11	18301-ZE2-V60	N2	193	17	18355-ZE2-W00	M12	187	7				
17252-899-000	L16	175	10	17510-ZE2-800ZE	N15	206	11	18310-ZB7-003	M15	190	1	18381-ZE2-800	M3	178	12	21111-766-000	2-F6	277	2
17316-611-000	E2	49	10	17510-ZE2-800ZF	N15	206	11	18310-ZD1-E31	N1	192	1		M7	182	9	21171-766-000	2-F9	280	1
17367-413-690	L16	175	11	17510-ZE2-801ZA	N15	206	11	18310-ZE2-013	M2	177	1		M12	187	9	21210-766-000	2-F6	277	3
17402-ZE2-810	L5	164	6	17510-ZE2-801ZC	N4	195	20	18310-ZE2-822	M2	177	1		M16	191	5	21281-740-020	2-F6	277	4
17403-ZE2-810	L5	164	7		N8	199	3	18310-ZE2-A01	M16	191	1	18381-ZE2-W10	M3	178	13	21510-889-750	2-E3	258	1
17410-ZE2-020	L4	163	6		N15	206	11	18310-ZE2-A11	M16	191	1		M6	181	8	21610-889-750	2-E3	258	2
	L5	164	8	17510-ZE2-801ZD	N15	206	11	18310-ZE2-U90	N1	192	1	18412-ZB7-000	M15	190	4	21691-889-750	2-E3	258	3
	L10	169	10	17510-ZE2-801ZE	N15	206	11	18310-ZE2-V60	N2	193	15	18413-ZB7-000	M15	190	5	21913-740-000	2-F6	277	5
17410-ZE3-840	L13	172	9	17520-ZA0-800	N7	198	10	18310-ZE2-W00	M5	180	1	18414-ZB7-000	M15	190	6	21914-740-000	2-F6	277	6
17410-ZH9-N00	M1	176	9		2-B4	211	11	18310-ZE2-W61	M11	186	1		M12	187	17				
17420-ZE2-000	L4	163	7	17620-899-013	N7	198	11	18313-ZE2-U50	M2	177	2	18430-ZK9-W50	M9	184	19				
	L5	164	9		N11	202	9	18320-ZB4-000	N1	192	2		M13	188	17	22000			
17470-ZE3-841	L13	172	10		2-B4	211	22	18320-ZE2-821	M2	177	3	22103-ZE2-620	2-E7	262	3	22121-889-750	2-E3	258	4
17470-ZE3-842	L13	172	10	17620-Z0T-305	N6	197	40	18320-ZE2-G30	M2	177	3	22201-822-610	2-E3	258	5	22201-822-610	2-E3	258	5
17475-ZE3-841	L13	172	11		N10	201	17	18320-ZE2-P30	M2	177	3	18434-ZF6-W40	M13	188	19	22311-822-610	2-E3	258	6
17476-ZE3-841	L13	172	12		2-B2	209	34	18320-ZE2-P50	M2	177	3	18434-ZK9-W40	M9	184	21	22350-822-610	2-E3	258	7
17500-ZE2-811ZA	N3	194	18	17620-ZE2-W00	N4	195	21	18320-ZE2-W01	M5	180	2	18436-ZH8-W40	M9	184	22	22411-822-611	2-E3	258	8
	N14	205	9		N9	200	4	18320-ZE2-W61	M11	186	2		M13	188	20	22421-822-610	2-E3	258	9
17500-ZE2-812ZA	N4	195	18		N15	206	12	18323-ZE2-W00	M6	181	3	18437-ZF6-W40	M9	184	23	22521-822-610	2-E3	258	10
	N14	205	9	17620-ZH7-023	N4	195	22	18323-ZE2-W60	M11	186	3		M13	188	21	22531-889-750	2-E3	258	11
17500-ZE2-813ZA	N4	195	18					18325-ZB4-000	N1	192	3	18438-ZF6-W40	M9	184	24	22535-822-610	2-E3	258	12
	N14	205	9										M13	188	22				

3

PART NO. INDEX

Part Number	Address	Page	Ref.	Part Number	Address	Page	Ref.	Part Number	Address	Page	Ref.	Part Number	Address	Page	Ref.
23000				28410-ZE2-W012B H13		108	2	31000				31610-ZE2-852ZB 2-D7		246	3
				28410-ZE2-W012D H13		108	2					31610-ZE2-853ZA 2-D8		247	4
23110-ZE2-610	2-E5	260	4	28410-ZE2-W012G H13		108	2	31100-ZE2-010	2-B6	213	9	31610-ZE2-853ZB 2-D8		247	4
23111-766-000	2-F7	278	1	28410-ZE2-W012J H13		108	2	31100-ZE2-812	2-B6	213	10	31610-ZE2-854ZA 2-D8		247	4
23114-766-000	2-F7	278	2	28410-ZE2-W012K H13		108	2	31100-ZE2-822	2-B6	213	11	31610-ZE2-854ZB 2-D8		247	4
23120-889-750	2-E3	258	13	28410-ZE2-W012L H13		108	2	31100-ZE2-832	2-B6	213	12	31610-ZE2-854ZF 2-D8		247	4
23161-822-611	2-E4	259	14	28410-ZE2-W012M H13		108	2	31100-ZE2-W01	2-B8	215	14	31610-ZE2-862ZB 2-D2		241	1
23218-766-000	2-F9	280	2	28410-ZE2-W012N H13		108	2	31100-ZE2-W11	2-B6	213	12	31610-ZE2-862ZD 2-D2		241	1
23220-ZE2-621	2-E7	262	4	28420-ZE8-812	I5	116	3	31161-ZE2-000	F1	64	21	31610-ZE2-872ZB 2-D7		246	3
23231-740-000	2-F8	279	1	28421-ZE2-W01	H14	109	3	31204-ZA0-003	2-B15	222	1	31610-ZE2-873ZA 2-D8		247	4
23341-766-000	2-F7	278	3	28422-ZE2-W01	H14	109	4	31210-ZB7-003	2-B15	222	2	31610-ZE2-873ZB 2-D8		247	4
23367-766-000	2-F7	278	4	28422-ZE8-811	I5	116	4	31210-ZE2-003	2-B15	222	2	31610-ZE2-874ZA 2-D8		247	4
23377-766-000	2-F7	278	5	28422-ZG3-004	I5	116	4	31211-ZE2-003	2-B15	222	3	31610-ZE2-874ZB 2-D8		247	4
23407-766-000	2-F8	279	2	28423-ZE1-711	I5	116	5	31212-ZE2-003	2-B15	222	4	31610-ZE2-874ZD 2-D8		247	4
23421-797-A00	2-F7	278	6	28423-ZG3-004	I5	116	5	31213-ZE2-003	2-B16	223	5	31610-ZE2-V41 2-D13		252	2
23425-766-000	2-F7	278	7	28424-ZE1-712	I5	116	6	31214-ZE2-003	2-B16	223	6	31610-ZE2-W01ZA 2-D4		243	1
23431-797-A00	2-F7	278	8	28431-ZE1-711	I5	116	7	31215-ZE2-003	2-B16	223	7	31610-ZE2-W01ZC 2-D4		243	1
23446-766-000	2-F7	278	9	28431-ZG3-004	I5	116	7	31216-ZE2-003	2-B16	223	8	31610-ZE2-W02ZA 2-D4		243	1
23511-740-000	2-F8	279	3	28432-ZG0-003	I5	116	8	31217-ZE2-003	2-B16	223	9	31610-ZE2-W02ZC 2-D4		243	1
23521-797-A00	2-F8	279	4	28432-ZG0-004	I5	116	8	31219-ZE2-003	2-B16	223	10	31610-ZE2-W02ZE 2-D4		243	1
23581-740-000	2-F6	277	7	28434-ZE8-812	I5	116	9	31231-ZE2-003	2-B16	223	11	31610-ZH9-W51ZA 2-D8		247	4
23710-ZE2-610	2-E5	260	5	28441-ZE1-711	I5	116	10	31232-ZB7-003	2-B16	223	12	31610-ZH9-W52ZA 2-D8		247	4
23710-ZE2-621	2-E7	262	5	28441-ZE2-W01	H15	110	5	31232-ZE2-013	2-C2	225	20	31610-ZH9-W52ZC 2-D8		247	4
23710-ZE2-R20	2-E7	262	5	28441-ZG3-004	I5	116	10	31232-ZE3-003	2-C2	225	20	31610-ZK2-W41ZA 2-D7		246	3
23710-ZK2-800	2-E5	260	5	28442-ZE1-713	I5	116	11	31233-ZE2-003	2-B16	223	13	31610-ZK2-W41ZC 2-D8		247	3
23711-822-610	2-E4	259	15	28442-ZE2-W01	H16	111	6	31425-ZB4-010ZA	2-F2	273	2	31610-ZK9-W41ZA 2-D2		241	1
				28443-ZE2-W01	H16	111	7	31462-ZB4-000	2-F2	273	3	31612-ZE2-003	2-C16	239	3
				28444-ZE2-W01	I1	112	8	31482-ZB4-003	2-F2	273	4		2-D2	241	2
				28450-ZE2-W11	2-B5	212	4	31483-ZB4-003	2-F2	273	5		2-D4	243	2
				28451-ZE2-W01	2-B5	212	5	31507-ZB7-000	2-E2	257	1		2-D8	247	5
24110-766-000	2-F7	278	10	28451-ZE3-A02	2-B6	213	6	31510-ZE1-811	2-B14	221	19	31613-880-810	2-D13	252	3
24122-766-000	2-F7	278	11	28461-ZE2-P51	I5	116	12	31510-ZE1-831	2-B10	217	4	31614-ZE2-003	2-C16	239	4
24126-766-000	2-F7	278	12	28461-ZE2-W02	I2	113	10	31510-ZE2-811	2-B10	217	5		2-D2	241	3
24271-765-000	2-F6	277	8	28461-ZE8-811	I5	116	12	31510-ZE3-003	2-B10	217	4		2-D4	243	3
24481-766-000	2-F6	277	9	28462-ZE2-A02	I5	116	13	31511-ZE2-000	2-B10	217	6		2-D9	248	6
24611-766-000	2-F7	278	13	28462-ZE2-W01	I2	113	11	31511-ZE2-W00	2-B14	221	17	31615-ZE2-003ZA 2-D9		248	7
				28462-ZE2-W11	I2	113	11	31512-ZB7-000	2-E2	257	2	31615-ZE2-003ZB 2-C16		239	5
				28462-ZE8-811	I5	116	13	31512-ZE2-000	2-B11	218	7		2-D2	241	4
				28469-ZE2-W01	I3	114	12	31512-ZG3-000	2-B14	221	21		2-D4	243	4
					I6	117	23	31513-ZB7-000	2-E2	257	3		2-D9	248	7
				28470-816-000	2-B6	213	8	31600-KE1-010	I9	120	8	31615-ZE2-003ZG 2-C16		239	5
				28480-ZE2-U50	I5	116	14	31600-ZE2-861	2-C16	239	1		2-D2	241	4
				28481-881-810	I5	116	15		2-D2	241	5		2-D4	243	4
				28481-ZE2-U50	I6	117	15		2-D7	246	2		2-D9	248	7
									2-F3	274	31	31620-ZG5-003	2-D4	243	5
				30000				31610-ZE2-013ZB	2-C16	239	2	31620-ZG5-013	2-D5	244	5
28400-ZE2-A01ZB I5	116	1						31610-ZE2-013ZD	2-C16	239	2	31620-ZG5-023	2-D5	244	5
28400-ZE2-A02ZB I5	116	1		30401-HA0-000	2-E1	256	1	31610-ZE2-812ZB 2-D7	246	3	31630-ZE1-003	2-B11	218	8	
28400-ZE2-W01ZA H11	106	1		30500-ZF6-W02	2-B9	216	1	31610-ZE2-812ZD 2-D7	246	3	31630-ZE1-013	2-B11	218	8	
28400-ZE2-W01ZB H12	107	1		30500-ZF6-W03	2-B10	217	1	31610-ZE2-822ZB 2-D7	246	3	31630-ZE2-841	2-B12	219	8	
28400-ZE2-W01ZD H12	107	1		30561-ZB4-000	2-D13	252	1	31610-ZE2-823ZB 2-D8	247	4	31630-ZE2-842	2-B12	219	8	
28400-ZE2-W01ZG H12	107	1			2-F2	273	1	31610-ZE2-824ZB 2-D8	247	4	31630-ZE2-861	2-B12	219	9	
28400-ZE2-W01ZJ H12	107	1			2-B10	217	2	31610-ZE2-824ZE 2-D8	247	4	31630-ZE2-E11	2-B10	217	5	
28400-ZE2-W01ZK H12	107	1		30600-ZE1-013	2-B10	217	2	31610-ZE2-832ZB 2-D7	246	3	31630-ZE2-W01	2-B12	219	10	
28400-ZE2-W01ZL H12	107	1		30700-ZB7-013	2-B14	221	20	31610-ZE2-833ZB 2-D8	247	4	31630-ZF1-801	2-B10	217	5	
28400-ZE2-W01ZM H12	107	1		30700-ZE1-013	2-B10	217	3	31610-ZE2-834ZB 2-D8	247	4	31651-ZE2-V41	2-D13	252	4	
28400-ZE2-W01ZN H12	107	1		30701-883-000	I9	120	7	31610-ZE2-834ZE 2-D8	247	4	31652-ZE2-V41	2-D13	252	5	
28410-ZE2-A01ZB I5	116	2			2-B12	219	12	31610-ZE2-842ZB 2-D7	246	3	31654-ZE2-V41	2-D13	252	6	
28410-ZE2-A02ZB I5	116	2						31610-ZE2-842ZD 2-D7	246	3	31655-ZB4-000	2-D13	252	7	
28410-ZE2-W01ZA H12	107	2													



PART NO. INDEX

2-G 5

Part Number	Address	Page	Ref.	Part Number	Address	Page	Ref.	Part Number	Address	Page	Ref.	Part Number	Address	Page	Ref.
35100-768-S01	2-F10	281	2	38000				63000				87522-ZH9-010	2-E8	263	1
35100-ZA0-013	2-F4	275	41										2-E13	268	28
35100-ZB4-013	2-F4	275	41	38220-ZE1-000	2-F4	275	47	63125-ZB7-000	2-B4	211	14		2-F4	275	62
35100-ZE2-023	2-C16	239	10	38220-ZE2-R70	2-F4	275	47	63132-ZB7-000	2-B4	211	15	87522-ZH9-820	2-E8	263	1
	2-D10	249	13	38240-898-000	2-D10	249	15					87522-ZH9-821	2-E9	264	1
35100-ZE2-033	2-C16	239	10	38240-VA3-900	2-D1	240	12	68000				87524-883-690	2-E13	268	23
	2-D10	249	13		2-D10	249	15					87525-ZE2-810	2-E9	264	1
35100-ZE2-842	2-D10	249	13	38240-ZE2-840	2-F4	275	48	68310-ZB7-000	2-F3	274	24	87526-ZH8-000	2-E10	265	6
35100-ZE2-843	2-D10	249	13	38250-898-000	2-D10	249	15	68312-ZB7-000	2-F3	274	25	87528-883-661	2-E11	266	7
35100-ZE2-862	2-D2	241	9	38250-898-000	2-F4	275	49	68325-899-000	F1	64	20	87528-898-620	2-E11	266	8
	2-D10	249	13	38250-ZA8-701	2-D1	240	13	68325-ZB4-000	F1	64	19		2-F4	275	64
35100-ZE2-W01	2-D5	244	9		2-D10	249	16					87528-ZE1-690	2-E10	265	7
35110-736-612	I10	121	11	38251-898-000	2-F4	275	50	75000				87528-ZE2-000	2-E11	266	7
	2-F10	281	3	38252-898-000	2-F4	275	51					87528-ZE2-810	2-E11	266	7
35110-766-003	I10	121	11	38253-898-000	2-F4	275	52	75133-960-000	16	117	16		2-F4	275	63
	2-F10	281	3	38254-898-000	2-F4	275	53					87528-ZF6-W40	2-E11	266	7
35111-880-003	2-C16	239	11	38306-KK4-000	2-E1	256	6	76000					2-F4	275	63
	2-D2	241	10										2-E11	266	7
	2-D5	244	10	39000				76122-952-000	N12	203	13	87528-ZH7-000	2-E11	266	7
	2-D10	249	14									87529-ZE2-010	2-D1	240	14
35111-880-013	2-F4	275	42	39500-ZB7-003	2-E1	256	7	81000					2-D10	249	17
	2-D1	240	11									87529-ZE2-020	2-D1	240	14
	2-D2	241	10	40000				81329-567-020	I10	121	13		2-D10	249	17
	2-D5	244	10						I13	124	7	87529-ZE2-811	2-D10	249	17
	2-D10	249	14	40111-740-000	2-F8	279	5					87529-ZE2-812	2-D10	249	17
35112-ZE2-U50	2-F4	275	43	40112-740-003	2-F8	279	6	83000				87529-ZE2-821	2-D10	249	17
35120-734-A21	2-F4	275	44	40181-776-000	2-F8	279	7					87529-ZE2-821	2-D10	249	17
35120-Z0D-V81	I10	121	12	40331-740-000	2-F8	279	8	83501-ZF1-000	2-E15	270	4	87529-ZE2-831	2-D10	249	17
35140-734-971	2-F4	275	45									87529-ZE2-860	2-D2	241	11
35146-734-A21	2-F4	275	46	41000									2-D5	244	12
								87000					2-D10	249	17
				41131-766-000	2-F9	280	3					87529-ZE2-861	2-D2	241	11
36000				41141-740-000	2-F7	278	14	87114-ZH7-000	2-E14	269	32		2-D5	244	12
								87117-ZB7-A30	2-E1	256	8	87529-ZE2-870	2-D10	249	17
36100-ZE1-015	I10	121	12	42000				87124-ZV3-010	2-E13	268	22	87529-ZH8-W40	2-D2	241	11
36100-ZF6-P81	I10	121	12					87135-ZE2-000	2-E14	269	30	87529-ZH9-W40	2-D10	249	17
	I12	123	21	42311-797-B00	2-F6	277	11					87529-ZH9-W41	2-D10	249	17
36100-ZH7-003	I10	121	12					87135-ZE2-010	2-E14	269	30	87530-ZE2-000	2-E12	267	9
	I12	123	21	50000				87135-ZE2-020	2-E14	269	30	87530-ZE2-810	2-E12	267	9
36100-ZH7-W41	I12	123	21									87530-ZE2-820	2-E12	267	9
36100-ZH8-W41	I10	121	12	50317-254-000	I10	121	13	87504-734-800	2-F4	275	54	87530-ZE2-W01	2-E12	267	9
36101-ZE1-010	2-B12	219	11		I12	123	20	87516-Z0D-800	2-E14	269	33	87530-ZE2-W10	2-E12	267	9
36101-ZE2-701	2-B12	219	11	50319-ZB2-000	N12	203	12					87530-ZE2-W41	2-E12	267	9
36103-ZE1-000	I12	123	18	50319-ZB7-000	2-E2	257	8	87520-ZH8-000	2-F5	276	73	87532-ZB4-G60	2-E12	267	10
	2-B12	219	12					87521-ZE2-W01	2-E8	263	1		2-E13	268	20
	2-D5	244	11	53000				87521-ZE2-W02	2-E9	264	2	87532-ZB4-H50	2-E12	267	10
	2-D12	251	30					87521-ZE2-W03	2-E10	265	2		2-E13	268	19
36106-892-003	2-F2	273	9	53149-964-003	J6	133	30	87521-ZE2-W04	2-E10	265	2	87532-ZE1-000	2-E12	267	11
36110-ZB4-701	2-F2	273	10									87532-ZE1-810	2-E12	267	11
36110-ZB4-702	2-F2	273	10	54000				87521-ZE2-W10	2-F4	275	69	87532-ZE1-810	2-E12	267	12
36135-PH3-004	L2	161	10					87522-883-660	2-E9	264	2	87532-ZH8-810	2-E12	267	12
36135-ZF6-D41	J5	132	29	54611-740-010	2-F10	281	4						2-E14	269	29
36135-ZV1-003	J5	132	29										2-F4	275	70
36150-ZB7-A01	2-E1	256	5	56000				87522-ZE1-010	2-E10	265	3	87532-ZH8-W40	2-E13	268	24
36160-ZB4-003	2-D15	254	6					87522-ZE1-810	2-E10	265	3		2-F4	275	65
36170-ZB4-003	J8	135	50	56850-767-000	2-F10	281	5	87522-ZH8-W40	2-E8	263	1	87533-ZB6-750	2-E12	267	13
				56862-767-300	2-F10	281	6		2-E13	268	27	87533-ZC0-630	2-E12	267	13
								87522-ZH8-W41	2-E9	264	1		2-F4	275	71
									2-F4	275	61	87534-ZE1-841	2-E12	267	14
									2-E8	263	1	87535-ZE1-840	2-E12	267	15

3

PART NO. INDEX

Part Number	Address	Page	Ref.	Part Number	Address	Page	Ref.	Part Number	Address	Page	Ref.	Part Number	Address	Page	Ref.
90013-883-000	M7	182	10	90206-ZE1-000	H10	105	15		2-D11	250	20	91202-Z2F-801	2-E4	259	23
	M12	187	10	90302-KF9-900	M9	184	27		2-F4	275	34	91203-952-771	E14	61	11
	2-B12	219	13		M14	189	25	90650-SD9-003	J6	133	36	91206-733-024	2-F6	277	15
	2-C12	235	23	90305-HA7-670	2-F6	277	13	90654-SA4-003	I11	122	15	91251-740-003	2-F6	277	16
	2-D1	240	15	90325-044-000	L4	163	10		I13	124	9	91251-766-003	2-F6	277	17
	2-D5	244	13		L5	164	12	90655-SD3-013	2-D13	252	19	91272-733-931	2-F6	277	18
	2-D11	250	18		L10	169	14	90658-SA0-003	E9	56	21	91301-766-003	2-F9	280	6
	2-D13	252	18		L14	173	17	90672-SA0-003	2-D1	240	18	91301-805-000	G5	84	14
	2-D15	254	7		M1	176	10		2-D3	242	18		2-E4	259	24
	2-F3	274	33	90380-MA6-010	2-D1	240	16		2-D6	245	16	91303-800-000	2-F6	277	19
	2-F5	276	75		2-D3	242	12		2-D11	250	21	91353-671-004	E14	61	12
	E2	49	11		2-D6	245	14		2-F4	275	35		N4	195	31
90014-ZE2-000					2-D11	250	19	90681-752-003	2-D13	252	20		N9	200	11
90015-883-000	2-B13	220	14		2-D11	250	19	90683-SA0-003	2-D13	252	21		N16	207	26
90015-ZE5-010	2-C12	235	24	90401-437-000	I6	117	18		2-E1	256	9		2-B3	210	13
90016-ZG9-N30	2-C13	236	25	90401-ZE2-620	2-E7	262	6		2-D13	252	20	91406-ZB4-000	2-D13	252	22
	2-C14	237	34	90402-ZE2-620	2-E7	262	7	90684-ZA0-601	I12	123	16		2-F3	274	15
	2-B14	221	18	90403-889-000	2-E4	259	18		2-B4	211	16	91406-ZE2-003	2-D1	240	19
90017-883-000	2-F8	279	9	90411-744-000	2-F8	279	11		2-B14	221	16		2-D3	242	19
90028-634-000	2-F7	278	15	90412-679-000	2-F7	278	16	90690-SA0-003	2-E1	256	10		2-D6	245	17
90029-611-010	2-F8	279	10	90429-PD1-000	2-F6	277	14		2-F3	274	27		2-D11	250	22
90030-PC8-000	E2	49	12	90431-ZE2-700	J6	133	32	90691-ZB7-003	2-E1	256	11		2-F4	275	36
90042-ZB7-000	E3	50	12	90432-ZE2-700	J6	133	33	90700-ZB7-000	2-E1	256	12		2-D16	255	8
90042-ZE2-000	E3	50	12	90433-ZE2-700	J6	133	34	90701-HC4-000	F12	75	18	91502-ZB4-701	N12	203	18
90042-ZE2-700	E2	49	12	90434-ZE2-700	J6	133	35		F14	77	17	91551-898-000	2-F3	274	16
90042-ZE2-T00	E4	51	13	90441-ZE2-010	E4	51	14		F15	78	17	91552-898-000	2-F7	278	20
90047-ZE2-000	E4	51	13	90446-KE1-000	E12	59	7		G2	81	17	91555-766-000	2-D14	253	23
90047-ZE3-791	E4	51	13	90453-360-000	2-F7	278	17		G5	84	12	91558-SD5-003	2-F3	274	17
90050-ZE1-000	M3	178	14	90454-KF0-000	2-F7	278	18	90741-805-000	G7	86	8	91601-ZB4-003	2-C1	224	15
				90471-ZE3-000	2-E5	260	7		2-E4	259	20				
	M8	183	11	90473-147-000	F9	72	14		2-E5	260	8	92000			
					F14	77	14	90741-889-000	2-E4	259	21				
	M10	185	32		F15	78	14	90741-889-810	G7	86	8				
	M12	187	11		G2	81	15		2-E4	259	20	92000-08025-0A	G8	87	13
	M14	189	30		G5	84	10		2-E6	261	8		2-E6	261	15
				90473-842-000	2-E5	260	6	90741-ZE2-000	G8	87	16	92101-08025-0A	G8	87	13
					2-E7	262	8	90745-ZE2-600	G8	87	8		2-E4	259	32
90050-ZE3-H00	M3	178	14		G8	87	14		2-E7	262	9		2-E6	261	15
90050-ZH8-W40	M9	184	26	90473-ZE2-000	2-F8	279	12	90745-ZK2-800	2-E6	261	8		2-F10	281	9
	M14	189	24	90501-740-010	2-F8	279	12	90745-ZK2-800	2-F8	279	13	92101-08028-0A	M15	190	7
				90503-898-000	N12	203	15	90752-735-000	2-F10	281	8	92101-08035-0A	2-E4	259	25
90055-ZE1-000	M4	179	15	90506-500-000	2-B3	210	12	90754-740-010	2-E16	271	16	92101-08035-0H	2-E4	259	25
					2-F3	274	13	90755-758-L00	2-E16	271	16	92800-12000	2-E4	259	26
	M8	183	12		G8	87	15	90801-ZE2-003	E13	60	9	92900-08032-0E	E4	51	13
	M9	184	17	90534-706-010	2-E4	259	19	90851-898-000	N12	203	16	92900-08060-0E	E4	51	13
	M12	187	12		2-E5	260	7	90852-898-000	2-F3	274	14				
	M14	189	31		2-F10	281	7	90854-ZB2-000	N12	203	17				
				90540-740-000	2-F9	280	4					93000			
90101-692-000	2-F2	273	12	90551-ZE1-000	H6	101	6					93403-04012-08	2-D14	253	24
90110-ZE2-003	2-B16	223	14	90602-896-000	F10	73	15	91001-878-003	2-F9	280	5	93494-06020-08	L4	163	11
90111-727-000	2-F6	277	12	90602-ZE1-000	F10	73	15	91051-727-000	2-F7	278	19		L5	164	13
90114-SA0-000	2-C13	236	26		F14	77	15	91201-889-003	F10	73	16		L11	170	15
90121-735-700	2-C14	237	29		F15	78	15	91201-890-003	E14	61	10		L14	173	18
90131-883-000	E12	59	6		G2	81	16		F10	73	16		M1	176	11
90142-MB0-000	L13	172	13	90605-230-000	2-C14	237	27		G3	82	25	93500-03006-1H	I15	126	17
90201-415-000	L4	163	8		2-C15	238	39		G5	84	13		K5	148	22
	L5	164	10	90624-SB0-003	L16	175	13		2-E4	259	22		K14	157	24
	L10	169	11	90630-751-000	2-D1	240	17		2-E6	261	9	93500-03008-1G	I15	126	17
	L14	173	14		2-D3	242	17		2-E7	262	10		K5	148	22
	M1	176	12		2-D6	245	15	91202-805-610	2-E4	259	23		K14	157	24
90201-ZE3-790	2-B6	213	13												
	2-B8	215	13												
90201-ZE3-V00	2-B7	214	13												



PART NO. INDEX

2-G 7

Part Number	Address	Page	Ref.	Part Number	Address	Page	Ref.	Part Number	Address	Page	Ref.	Part Number	Address	Page	Ref.	
94050-06000	2-F4	275	67	94540-04018	2-D16	255	10	N5	196	38		2-F3	274	29		
94050-08000	M4	179	17	94540-07010	J6	133	43	N10	201	15	98079-55854	E6	53	19	99101-ZH7-0880	
		19						N12	203	22	98079-55855	E7	54	19	K8	
	M8	183	13	95000				2-B2	209	32	98079-56841	E7	54	19	99101-ZH7-0900	
		14						2-B3	210	18		2-F3	274	29	99101-ZH7-0920	
	M12	187	14	95001-45150-40	N12	203	20	2-E6	261	11	98079-56846	E9	56	19	99101-ZH8-0750	
	M14	189	32	95001-45165-40	N12	203	20	2-E7	262	12	98079-56854	E8	55	19	J2	
	M16	191	8	95001-45180-40	N12	203	20	95701-08030-00	2-F6	277	24	98079-56855	E8	55	19	J7
	N2	193	11	95001-45190-40	N12	203	20	95701-08032-08	2-E4	259	31		2-F3	274	29	J8
	N5	196	33	95001-45222-40	N5	196	35	95701-08035-00	F12	75	19	98200-30500	2-D1	240	24	J8
	N9	200	12		N9	200	13		F14	77	18		2-D12	251	27	L1
	2-B1	208	29		2-B1	208	30		G2	81	19		2-D14	253	29	J2
	2-B3	210	14	95001-45260-40	N12	203	20		G5	84	16		2-E1	256	13	J7
	2-F4	275	68	95001-45430-40	2-B3	210	16	95701-08040-00	2-E7	262	13	98200-31000	2-F4	275	58	J8
94050-10000	E14	61	13	95002-02070	J6	133	44		2-C1	224	19		2-D14	253	30	K7
94070-06080	2-C1	224	18		J8	135	49		2-E6	261	13		2-E1	256	14	L1
94101-04800	2-D6	245	23	95002-02080	N5	196	36	95701-08070-00	2-E7	262	13	98200-31500	2-F4	275	58	99101-ZH8-0820
	2-D12	251	29		N7	198	15		N2	193	14		2-D3	242	16	J2
94101-06800	F11	74	17		N10	201	14	95701-10080-00	E6	53	18		2-D12	251	27	J7
	F14	77	16		N12	203	21	95701-10115-00	2-F6	277	25	98200-32500	2-D6	245	21	K7
	F15	78	16		2-B2	209	31	95701-10125-00	2-F10	281	10					K8
	G2	81	18		2-B3	210	17	95701-10160-00	2-F10	281	11	99000				K9
	G5	84	15		2-B4	211	17	95725-10080-00	E6	53	18					K14
94101-08000	N5	196	39	95002-02100	N5	196	37	95801-08020-18	2-F2	273	11	99001-10120	2-E16	271	20	L1
94103-05000	J6	133	40		N7	198	16	95900-08025-00	2-E4	259	32		2-F1	272	9	99101-ZH8-0850
94103-05700	M9	184	30		2-B4	211	18	95900-08035-00	F15	78	18	99001-10140	2-E16	271	21	K8
	M14	189	28	95002-02120	2-B4	211	19					99001-14170	2-E16	271	22	K9
94103-06000	I6	117	20	95002-40800-08	J8	135	51	96000				99003-30000	2-F1	272	10	K14
94109-12000	E12	59	8	95002-45000	L16	175	17					99003-50000	2-F1	272	11	99101-ZH8-0880
	2-E4	259	27	95003-09023-31	L16	175	18	96100-60040-00	2-F7	278	21	99004-21003	2-E16	271	23	K9
94111-03800	J2	129	30	95003-09038-31	L16	175	19	96100-62020-00	E16	63	16		2-F1	272	12	K14
	L1	160	28	95005-11100-30	E5	52	17		F12	75	20	99005-01000	2-F1	272	13	99101-ZH8-0900
94111-04800	2-D1	240	23	95005-11105-30	E4	51	17		F15	78	19	99008-02000	2-F1	272	14	K9
	2-D3	242	15	95005-35030-10	J7	134	46	96100-62030-00	G2	81	20	99008-02300	2-E16	271	24	99101-ZH8-0920
	2-D6	245	20	95005-35065-10	J6	133	45		2-F7	278	22	99101-ZF5-0750	J7	134	47	K9
	2-D12	251	26	95005-35130-10	J7	134	46		2-F8	279	15	99101-ZF5-0780	J2	129	31	99104-ZE0-0450
94111-05000	M10	185	31	95005-35495-11	J6	133	45	96100-62040-00	2-F9	280	9		J7	134	47	K10
	M14	189	29	95005-35695-10	J8	135	52		F14	77	19		L1	160	29	K15
94111-08800	2-E4	259	28	95701-06008-00	I4	115	14		F15	78	20	99101-ZF5-0800	I15	126	18	99204-ZA0-0450
94251-08000	E15	62	14		I12	123	17		G3	82	21		J2	129	31	99204-ZE0-0380
	2-B3	210	15		I13	124	11	96100-62050-00	2-E4	259	33		J7	134	47	K9
94251-10000	E16	63	14	95701-06010-00	N2	193	12	96100-62060-00	F13	76	21		K6	149	24	99204-ZE0-0400
94252-08000	2-E16	271	17						F14	77	20		L1	160	29	K14
94301-08140	2-E4	259	29	95701-06012-00	E16	63	15		F15	78	21	99101-ZF5-0820	I15	126	18	L1
	2-E6	261	10		N2	193	12		G3	82	22		J2	129	31	99204-ZE0-0450
	2-E7	262	11						G5	84	17		J7	134	47	J8
94301-12200	E4	51	15		2-D14	253	28		G8	87	9		K6	149	24	99204-ZE2-0380
94305-20122	I16	127	23	95701-06018-00	2-F3	274	18		2-E4	259	34		L1	160	29	K10
	K6	149	23	95701-06020-00	2-F3	274	18		2-E6	261	14	99101-ZF5-0850	I15	126	18	99204-ZE2-0400
	K14	157	25	95701-06022-00	N12	203	22		2-E7	262	14		K6	149	24	K15
	L2	161	11	95701-06025-00	2-F4	275	37	96100-63020-00	F14	77	21	99101-ZF5-0880	K6	149	24	
94510-11000	E4	51	16	95701-06032-00	2-F6	277	22		G3	82	23	99101-ZF5-0900	K6	149	24	
94510-22000	2-F9	280	7	95701-06040-00	2-F6	277	23		2-E7	262	15	99101-ZF5-0920	K6	149	24	
94510-25000	2-F6	277	20	95701-06040-08	2-F3	274	19	96140-62030-00	2-F7	278	23	99101-ZH7-0750	J7	134	47	
	2-F8	279	14	95701-06050-08	2-E4	259	30					99101-ZH7-0780	J7	134	47	
94520-50000	2-F9	280	8	95701-06060-00	I6	117	21	98000				99101-ZH7-0800	J7	134	47	
94520-52000	2-F6	277	21	95701-06075-00	I6	117	22					99101-ZH7-0820	K8	151	24	
94540-02010	J6	133	41	95701-08020-00	N2	193	13	98079-55841	E6	53	19		K14	157	26	
94540-04010	J6	133	42	95701-08025-00	G8	87	17	98079-55846	E8	55	19	99101-ZH7-0850	K8	151	24	

3

PART NAME INDEX

Part name	Address	Page	Ref.	Part name	Address	Page	Ref.	Part name	Address	Page	Ref.
[A]											
ALERT UNIT, OIL	F1	64	18	BEARING, RADIAL BALL, 6206	G8	87	9	BOLT, FLANGE, 6X40	2-F3	274	19
	I7	118	1		2-E4	259	34		2-F6	277	23
	I12	123	19		2-E6	261	14	BOLT, FLANGE, 6X50	2-E4	259	30
	2-D6	245	22	BEARING, RADIAL BALL, 62/22 ...	2-E7	262	14	BOLT, FLANGE, 6X60	I6	117	21
	2-D7	246	1		2-F9	280	5	BOLT, FLANGE, 6X75	I6	117	22
	2-D12	251	28	BEARING, RADIAL BALL, 6302	F14	77	21	BOLT, FLANGE, 6X8	I4	115	14
ARMATURE COMP.	2-B16	223	9		G3	82	23		I12	123	17
ARM COMP., GOVERNOR	2-C3	226	1	BODY, OIL CAP	2-E7	262	15		I13	124	11
ARM COMP., SUB GOVERNOR	2-C14	237	35	BOLT-WASHER, 4X12	2-F10	281	6	BOLT, FLANGE, 8X16	2-F6	277	12
ARM, GOVERNOR	2-C3	226	2	BOLT-WASHER, 2-D14	2-D14	253	24	BOLT, FLANGE, 8X20	N2	193	13
ARM, SELECT FORK	2-F7	278	12	BOLT-WASHER, 5X14	2-C2	225	21		2-F2	273	11
ARM, VALVE ROCKER	H8	103	3	BOLT-WASHER, 6X20	L4	163	11	BOLT, FLANGE, 8X25	G8	87	17
	H9	104	3		L5	164	13		N5	196	38
ARRESTER, SPARK	M3	178	11		L11	170	15		N10	201	15
	M6	181	7		L14	173	18		N12	203	22
	M12	187	7	BOLT-WASHER, 6X22	M1	176	11		2-B2	209	32
	N1	192	9		L4	163	11		2-B3	210	18
AUTO-THROTTLE ASSY.	2-D15	254	3		L5	164	13		2-E4	259	32
					L11	170	15		2-E6	261	11
					L14	173	18		2-E7	262	12
					M1	176	11	BOLT, FLANGE, 8X30	2-F6	277	24
					I6	117	11	BOLT, FLANGE, 8X32	2-E4	259	31
				BOLT, 6MM	H6	101	5	BOLT, FLANGE, 8X35	F12	75	19
				BOLT, CONNECTING ROD	2-E4	259	26		F14	77	18
BAG SET, TOOL	2-E15	270	7	BOLT, DRAIN PLUG, 12MM	E12	59	6		F15	78	18
BAG, TOOL, 200MM	2-F1	272	14	BOLT, DRAIN PLUG, 12X15	2-F6	277	25		G2	81	19
BAG, TOOL, 230MM	2-E16	271	24	BOLT, FLANGE, 10X115	2-F10	281	10		G5	84	16
BAND	2-C16	239	9	BOLT, FLANGE, 10X125	2-F10	281	11		2-E7	262	13
	2-D2	241	8	BOLT, FLANGE, 10X160	2-F10	281	11	BOLT, FLANGE, 8X40	2-C1	224	19
	2-D5	244	8	BOLT, FLANGE, 10X80	E6	53	18		2-E6	261	13
	2-D10	249	12	BOLT, FLANGE, 10X80	I4	115	14		2-E7	262	13
BAND, TOOL SETTING	2-F3	274	26		I12	123	17		N2	193	12
BARREL ASSY., CYLINDER	E10	57	1		N2	193	12	BOLT, FLANGE, 8X70	N2	193	14
	E11	58	1					BOLT, GOVERNOR ARM	2-C12	235	24
	E12	59	1	BOLT, FLANGE, 6X12	E12	59	5	BOLT, HEAD COVER	E2	49	11
BAR A, HANDLE	2-F1	272	13		E16	63	15	BOLT, HEX.	G8	87	13
BASE COMP., CONTROL	2-C10	233	16					BOLT, HEX., 3/8-24UNF	2-E6	261	15
BASE COMP., MUFFLER COVER	M9	184	22		I11	122	14	BOLT, HEX., 8X24	2-F7	278	15
	M13	188	20		I13	124	8	BOLT, HEX., 8X25	G8	87	13
BASE, BATTERY	2-E2	257	8		M7	182	10		2-E4	259	32
BASE, CORD CLIP	2-E1	256	12		M12	187	10		2-E6	261	15
BEARING, NEEDLE, 20X24X17	2-F7	278	19		N2	193	12		2-F10	281	9
BEARING, RADIAL BALL, 6004 ...	2-F7	278	19					BOLT, HEX., 8X28	M15	190	7
BEARING, RADIAL BALL, 6202 ...	E16	63	16		2-B12	219	13	BOLT, HEX., 8X35	2-E4	259	25
	F12	75	20		2-C12	235	23	BOLT, PIVOT, 8MM	H10	105	14
	F15	78	19		2-D1	240	15	BOLT, REEL COVER	I6	117	17
	G2	81	20		2-D5	244	13	BOLT, SPECIAL, 6X21	2-F8	279	9
BEARING, RADIAL BALL, 6203 ...	2-F7	278	22		2-D11	250	18	BOLT, SPECIAL, 8MM	2-F8	279	10
	2-F8	279	15		2-D13	252	18	BOLT, STUD, 8X111	E2	49	12
	2-F9	280	9		2-D14	253	28	BOLT, STUD, 8X115	E2	49	12
BEARING, RADIAL BALL, 6203U ..	2-F7	278	23		2-D15	254	7	BOLT, STUD, 8X123	E3	50	12
BEARING, RADIAL BALL, 6204 ...	F14	77	19		2-F3	274	33	BOLT, STUD, 8X32	E4	51	13
	F15	78	20		2-F5	276	75	BOLT, STUD, 8X34	E4	51	13
	G3	82	21	BOLT, FLANGE, 6X18	2-F3	274	18	BOLT, STUD, 8X40	E4	51	13
BEARING, RADIAL BALL, 6205 ...	2-E4	259	33	BOLT, FLANGE, 6X20	2-F3	274	18	BOLT, STUD, 8X47	E4	51	13
BEARING, RADIAL BALL, 6206 ...	F13	76	21	BOLT, FLANGE, 6X22	N12	203	22	BOLT, STUD, 8X60	E4	51	13
	F14	77	20	BOLT, FLANGE, 6X25	2-F4	275	37	BOLT, STUD, 8X98	E3	50	12
	F15	78	21	BOLT, FLANGE, 6X28	2-B13	220	14	BOX ASSY., CONTROL	2-C16	239	2
	G3	82	22	BOLT, FLANGE, 6X32	2-B14	221	18		2-D2	241	1
	G5	84	17		2-F6	277	22		2-D4	243	1



PART NAME INDEX

2-H 2

Part name	Address	Page	Ref.	Part name	Address	Page	Ref.	Part name	Address	Page	Ref.
BOX ASSY., CONTROL	2-D7	246	3	CAP, CHOKE DUST	J4	131	10	CHOKE SET	L2	161	1
	2-D8	247	3		K16	159	10	CIRCLIP, 5MM	2-C14	237	27
			4	CAP, CHOKE LEVER	2-D15	254	1		2-C15	238	39
BOX ASSY., REMOTE CONTROL	2-D13	252	2	CAP, ENGINE KILL SWITCH	2-F4	275	46	CIRCLIP, EXTERNAL, 11MM	E4	51	16
BOX COMP., REMOTE CONTROL	2-D13	252	4	CAP, FUEL METER	N7	198	8	CIRCLIP, EXTERNAL, 22MM	2-F9	280	7
BOX, TOOL	2-E15	270	4	CAP, LENS	2-F4	275	51	CIRCLIP, EXTERNAL, 25MM	2-F6	277	20
BRACKET, CASE MOUNTING	2-C16	239	4	CAP, MUFFLER	M2	177	8		2-F8	279	14
	2-D2	241	3		M6	181	5	CIRCLIP, INTERNAL, 50MM	2-F9	280	8
	2-D4	243	3		M11	186	5	CIRCLIP, INTERNAL, 52MM	2-F6	277	21
	2-D9	248	6	CAP, OIL	2-F6	277	10	CLAMPER, CORD	2-B10	217	6
BRACKET, CENTER	2-B15	222	3	CAP, OIL FILLER	F8	71	13		2-B14	221	17
BRACKET, FR.	2-B15	222	4		F14	77	13	CLAMP, TUBE	J8	135	51
BRACKET, RELAY BOX	2-D13	252	7		F15	78	13	CLIP A, AIR CLEANER WIRE	L15	174	8
BRACKET, STRAINER CUP SETTING	2-B4	211	15		G1	80	5	CLIP B, AIR CLEANER WIRE	L15	174	9
BRACKET, WIRE HARNESS CLIP ...	2-D13	252	12		G4	83	4	CLIP, BREATHER TUBE	E2	49	10
BRUSH	2-B16	223	7	CAP, PRE AIR CLEANER	L13	172	11		L16	175	16
BUSH, ARM PIVOT	J6	133	30	CAP, REDUCTION OIL	2-E4	259	16	CLIP, GOVERNOR HOLDER	F10	73	15
BUSH, AUTO-THROTTLE LEVER	2-D16	255	8	CAP, THERMO SWITCH	E9	56	20		F14	77	15
BUSH, CONTROL KNOB	2-F2	273	9	CARBURETOR ASSY.	I14	125	7		F15	78	15
BUSH, FUEL PURGE	N7	198	6		J1	128	10		G2	81	16
					J3	130	8		G5	84	11
[C]					J4	131	8	CLIP, HARNESS	I12	123	16
					J12	139	8		2-B4	211	16
CABLE ASSY., EARTH	2-D13	252	17		J13	140	8		2-B14	221	16
	2-E2	257	7		J14	141	8		2-D13	252	20
CABLE ASSY., STARTING	2-D13	252	14		K13	156	9		2-E1	256	11
	2-E2	257	4		K16	159	8	CLIP, HIGH TENSION CORD	I9	120	7
CAMSHAFT ASSY.	H7	102	1		L2	161	2		2-B12	219	12
	H8	103	1	CASE COMP., AIR CLEANER	L15	174	4	CLIP, PISTON PIN, 18MM	H6	101	6
CAP ASSY., NOISE SUPPRESSOR ..	2-B10	217	3	CASE COMP., FUSE	2-F4	275	47	CLIP, PURSE LOCK	2-D1	240	17
	2-B14	221	20	CASE COMP., L. TRANSMISSION ...	2-F6	277	3		2-D3	242	17
CAP ASSY., OIL FILLER	F4	67	4	CASE COMP., PRE AIR CLEANER ...	L13	172	10		2-D6	245	15
			5	CASE COMP., RECOIL STARTER	H12	107	2		2-D11	250	20
	F13	76	22		H13	108	2		2-F4	275	34
			23		I5	116	2	CLIP, TRUNK & FUEL OPENER WIRE	2-D13	252	19
	F14	77	4	CASE COMP., STARTER	I5	116	2	CLIP, TUBE	I7	118	2
			5	CASE, CONTROL	2-C16	239	3		J6	133	44
	F15	78	4		2-D2	241	2		J8	135	49
			5		2-D4	243	2		L16	175	17
	G1	80	4		2-D8	247	5		N5	196	36
			6		2-F2	273	2				37
	G3	82	24	CASE, REDUCTION	2-E3	258	1		N7	198	15
CAP COMP., AIR CLEANER	L4	163	7	CASE, R. TRANSMISSION	2-F6	277	2				16
	L5	164	9	CASE, SIDE CLUTCH BEARING	2-F8	279	4		N10	201	14
CAP COMP., FUEL FILLER	N4	195	21	CENTER, CLUTCH	2-E3	258	4		N12	203	21
			22	CENTER, CLUTCH WEIGHT	2-E3	258	12		2-B2	209	31
	N6	197	40	CHAIN, DRIVE	2-E4	259	14		2-B3	210	17
	N7	198	11	CHAIN, P.T.O. DRIVE	2-E5	260	3		2-B4	211	17
	N9	200	4	CHAMBER SET, FLOAT	I14	125	4				18
			5		J1	128	5				19
	N10	201	17		J3	130	4	CLIP, VALVE GUIDE	E1	48	4
	N11	202	9		J10	137	4	CLIP, WIRE	2-D13	252	1
	N15	206	12		K11	154	28		2-F2	273	1
	N16	207	13		K13	156	4	CLIP, WIRE HARNESS	E9	56	21
	2-B2	209	34		K15	158	28		J6	133	36
	2-B3	210	5		K16	159	4		L16	175	13
			6	CHOKE SET	I16	127	20		2-D14	253	23
	2-B4	211	22		J12	139	7	CLIP, WIRE HARNESS, 25MM	2-D13	252	21
CAP, CHOKE DUST	J1	128	12		K13	156	8		2-E1	256	9

4

PART NAME INDEX

Part name	Address	Page	Ref.	Part name	Address	Page	Ref.	Part name	Address	Page	Ref.
CLIP, WIRE HARNESS, 6MM	I11	122	15	COVER ASSY., CRANKCASE	F16	79	3	DOWEL PIN, 8X12.....	F15	78	17
	I13	124	9		G4	83	2		G2	81	17
CLUTCH COMP., OVERRUNNING	2-B16	223	6	COVER ASSY., REDUCTION CASE ...	2-E7	262	1		G5	84	12
COCK ASSY., ELECTRIC FUEL	N3	194	7	COVER B, MAGNETIC SWITCH	2-E2	257	6	DOWEL PIN, 8X14.....	2-E4	259	29
	2-B4	211	5	COVER COMP., AIR CLEANER	L13	172	5		2-E6	261	10
COCK ASSY., FUEL	N11	202	2		L15	174	6		2-E7	262	11
COIL ASSY., CHARGE	2-B10	217	5					DRIVER 3, MINUS SCREW.....	2-F1	272	10
	2-B11	218	8	COVER COMP., FAN	I8	119	3	DRIVER, SCREW.....	2-E15	270	8
	2-B12	219	8		I13	124	4				
			10	COVER COMP., HEAD	E2	49	6	[E]			
COIL ASSY., IGNITION	2-B9	216	1	COVER COMP., MUFFLER	M9	184	20	ELBOW COMP., AIR CLEANER.....	L4	163	6
	2-B10	217	1	COVER COMP., MUFFLER RR.	M13	188	18		L5	164	8
COIL ASSY., LAMP	2-B10	217	4		M9	184	21		L10	169	10
			5	COVER, AIR CLEANER	M13	188	19		L13	172	9
	2-B14	221	19		L3	162	3	ELEMENT, AIR CLEANER.....	L3	162	1
COLLAR B, AIR CLEANER	L3	162	5		L5	164	3		L5	164	7
	L5	164	5		L8	167	4		L7	166	2
	L10	169	9						L13	172	2
	L13	172	8	COVER, BATTERY	M1	176	4		L15	174	2
	M1	176	8	COVER, BATTERY TERMINAL	2-E2	257	3		M1	176	2
COLLAR, 10X16X53	N2	193	17	COVER, BEVEL	2-D13	252	15	EMBLEM.....	2-E9	264	2
COLLAR, AIR CLEANER	L3	162	4	COVER, MAGNETIC SWITCH	2-E2	257	5		2-E10	265	2
	L5	164	4		2-E2	257	5		2-F4	275	69
	L9	168	8	COVER, REDUCTION	2-F9	280	1	EMBLEM, UPPER.....	2-E9	264	1
	L13	172	7					E-RING, 2MM.....	J6	133	41
	M1	176	7	COVER, REMOTE CONTROL	2-D13	252	15	E-RING, 4MM.....	J6	133	42
COLLAR, AIR CLEANER CASE	M9	184	18	COVER, STARTER REEL	I5	116	9		2-D16	255	10
	M12	187	16	CRANKSHAFT COMP.	G6	85	2	E-RING, 7MM.....	J6	133	43
COLLAR, CONTROL BOX	2-F3	274	16					[F]			
COLLAR, INPUT SHAFT	2-F7	278	2					FAN, COOLING.....	2-B5	212	2
COLLAR, LEVER	J6	133	35		G7	86	4	FILTER COMP., FUEL.....	N7	198	14
COLLAR, LOW IDLE GEAR	2-F7	278	20						N12	203	11
COLLAR, ROTO-STOP	I6	117	16		G8	87	10	FILTER, CUP.....	N11	202	5
COLLAR, SETTING	J4	131	12					FILTER, DRAIN TUBE.....	L16	175	11
	K10	153	27	CUP ASSY., FUEL STRAINER	N3	194	17	FILTER, FUEL.....	N4	195	25
	K13	156	12		2-B4	211	10				26
	L2	161	4	CUP, FUEL STRAINER	K4	147	21		N9	200	7
COLLAR, STOPPER	2-C12	235	21		K14	157	23				8
	2-C14	237	33		N3	194	16		N16	207	18
COLLAR, TANK CUSHION	N12	203	18		N11	202	6				19
CONTACTOR ASSY.	2-B15	222	1	CUSHION, C.D.I. UNIT	2-B4	211	9				
CONTROL ASSY.	2-C6	229	6		2-E1	256	1				
			7	[D]							
			8	DEFLECTOR COMP., MUFFLER	M9	184	19	FILTER, OUTER.....	2-B4	211	12
			10		M12	187	17		L8	167	3
CONTROL UNIT, SOLENOID	2-E1	256	5		M13	188	17		L13	172	3
CORD, EARTH	F1	64	21	DIAPHRAGM ASSY.	J5	132	25		M1	176	3
CORD, ENGINE KILL SWITCH	2-F4	275	43	DIODE ASSY.	2-D13	252	10	FLANGE COMP., BAFFLE.....	M3	178	10
CORD, STOP SWITCH	2-B12	219	11		2-F2	273	6	FLOAT SET.....	I14	125	3
COUNTERSHAFT COMP.	2-E7	262	4						J1	128	3
COUPLER COMP.	2-F4	275	40						J3	130	3
COVER ASSY., CHAIN CASE	2-E5	260	1	DIODE ASSY., SOLENOID	2-E1	256	2		J10	137	3
COVER ASSY., CRANKCASE	F2	65	3	DISK, CLUTCH FRICTION	2-E3	258	5		K13	156	3
	F3	66	3	DOWEL PIN, 12X20	E4	51	15		K16	159	3
	F4	67	3	DOWEL PIN, 8X12	F12	75	18	FLYWHEEL COMP.	2-B6	213	9
	F14	77	2		F14	77	17				10
	F15	78	3								



PART NAME INDEX

2-H 4

Part name	Address	Page	Ref.	Part name	Address	Page	Ref.	Part name	Address	Page	Ref.
FLYWHEEL COMP.	2-B6	213	11	GEAR, SIDE CLUTCH	2-F8	279	3	HOLDER, GOVERNOR WEIGHT	F7	70	10
			12	GEAR, SIDE CLUTCH DRIVE	2-F8	279	2		F14	77	10
	2-B8	215	14	GOVERNOR ASSY.	F6	69	8		F15	78	10
FORK, SIDE CLUTCH	2-F8	279	5		F14	77	8		G2	81	12
FUSE, BLADE	2-D1	240	24		F15	78	8		G4	83	7
	2-D3	242	16		G2	81	10	HOLDER, LENS	2-F4	275	53
	2-D6	245	21		G4	83	5	HOLDER, STOP SWITCH CORD	I12	123	18
	2-D12	251	27	GRID, AIR CLEANER	L3	162	2		2-B12	219	12
	2-D14	253	29		L5	164	2		2-D5	244	11
			30	GRIP	2-E15	270	9		2-D12	251	30
	2-E1	256	13	GRIP, REINFORCEMENT	I3	114	12	HOLDER, WIRE	2-C12	235	20
			14		I6	117	23		2-C15	238	38
	2-F4	275	58	GRIP, SCREW DRIVER	2-F1	272	11				
				GRIP, STARTER	I2	113	10				
					I5	116	12				
[G]				GROMMET	2-D13	252	8				
GASKET	N3	194	14	GROMMET, AIR CLEANER	L8	167	6	[I]			
	2-B4	211	8		L13	172	6	IDLER, VERTICAL STARTER	I5	116	15
GASKET KIT	2-F11	282	1		M1	176	5		I6	117	15
	2-F12	283	1	GROMMET, CHOKE ROD	J5	132	27	INSULATOR	2-B16	223	13
GASKET SET	I14	125	1	GROMMET, CORD	2-B11	218	7	INSULATOR, CARBURETOR	I14	125	10
	J1	128	1		2-B14	221	21		J1	128	16
	J3	130	1		2-F4	275	38		J4	131	13
	J9	136	1	GROMMET, DRAIN HOLE	I10	121	13		J16	143	12
	K13	156	1		I13	124	7		K14	157	14
	K16	159	1	GROMMET, FENDER	J6	133	31		K16	159	12
GASKET, CYLINDER HEAD	E1	48	5		L16	175	12		L2	161	5
GASKET, EX. PIPE	M3	178	9	GROMMET, MAIN CORD	2-F2	273	4	[J]			
	M6	181	6	GROMMET, SWITCH CORD	2-F2	273	5	JET SET, PILOT,	I16	127	19
	M12	187	6	GROMMET, TUBE	2-F3	274	17		J2	129	32
	M14	189	33	GROMMET, WIRE CORD	2-B4	211	13		J8	135	48
	M15	190	3	GUIDE, CHOKE ROD	J5	132	28		K9	152	25
	M16	191	4	GUIDE, EX. VALVE	E1	48	3		K10	153	25
	N1	192	7	GUIDE, IN. VALVE	E1	48	2		K14	157	27
	N2	193	16	GUIDE, MUFFLER	M3	178	8		K15	158	27
			18	GUIDE, PRE AIR CLEANER	L13	172	12		L1	160	30
	2-F3	274	20	GUIDE, UNDER AIR	2-F3	274	24	JET, MAIN,	I15	126	18
	2-F5	276	74						J2	129	31
GASKET, MUFFLER	M3	178	12	[H]					J7	134	47
			13	HANDLE, BOX WRENCH	2-E16	271	14		J8	135	47
	M6	181	8	HARNES ASSY., SUB WIRE	2-C16	239	7		K6	149	24
	M7	182	9		2-D2	241	6		K7	150	24
	M12	187	8		2-D5	244	6		K8	151	24
			9		2-D9	248	9		K9	152	24
	M16	191	5		2-E1	256	4		K14	157	26
GAUGE ASSY., FUEL	N4	195	19		2-F3	274	32	JET, PILOT,	L1	160	29
	N14	205	10	HARNES ASSY., WIRE	2-D13	252	11		L2	161	12
GAUGE ASSY., THICKNESS	2-E15	270	10	HEAD COMP., CYLINDER	E1	48	1	JOINT, BREATHER	2-F6	277	1
GAUGE, OIL LEVEL	2-E4	259	17	HOLDER, BRUSH	2-B16	223	11	JOINT, FUEL	2-B3	210	2
GEAR COMP., HIGH & LOW DRIVE ..	2-F7	278	7	HOLDER, CABLE	2-C9	232	14	JOINT, FUEL TANK	N3	194	10
GEAR, COUNTER	2-F7	278	3		2-C15	238	37		N8	199	2
GEAR, DRIVE	2-F7	278	6		2-F4	275	59		N14	205	5
GEAR, DRIVEN	2-F7	278	8	HOLDER, CLUTCH SPRING	2-E3	258	9	JOINT, ROD	J1	128	23
GEAR, DRIVEN BEVEL	2-F7	278	14	HOLDER, CLUTCH WEIGHT	2-E3	258	11		J4	131	20
GEAR, DRIVE PINION	2-B16	223	5	HOLDER, FUEL FILTER	N4	195	27		K16	159	19
GEAR, FINAL	2-F6	277	7		N9	200	9				
GEAR, HIGH & LOW CHANGE	2-F7	278	4		N16	207	20	[K]			
GEAR, LOW IDLE	2-F7	278	9		2-B3	210	10	KEY ASSY., COMBINATION SWITCH ..	I10	121	11
GEAR, PRIMARY DRIVE	2-E7	262	3								

4

PART NAME INDEX

Part name	Address	Page	Ref.	Part name	Address	Page	Ref.	Part name	Address	Page	Ref.
KEY ASSY., COMBINATION SWITCH	2-F10	281	3	MARK, AIR CLEANER CAUTION	2-E13	268	23	NUT-WASHER, 6MM	2-C1	224	18
KEY COMP.	2-C16	239	11	MARK, AIR CLEANER SALES POINT -	2-E12	267	15	NUT, AXLE, 16MM	2-F6	277	13
	2-D1	240	11	MARK, CAUTION	2-E8	263	1	NUT, CAP, 6MM	I6	117	19
	2-D2	241	10		2-E9	264	1		L4	163	8
	2-D5	244	10		2-E10	265	3		L5	164	10
	2-D10	249	14				4		L10	169	11
	2-F4	275	42		2-E13	268	27		L14	173	14
KEY, 6.3X6.3X33	2-E6	261	8		2-F4	275	61		M1	176	12
KEY, 6.3X6.3X43	G8	87	8				70	NUT, FLANGE, 10MM	E14	61	13
	2-E7	262	9	MARK, CHOKE	2-E10	265	7	NUT, FLANGE, 5MM	L16	175	14
KEY, 7X7X33	G7	86	8		2-E11	266	7	NUT, FLANGE, 6MM	J6	133	39
	2-E4	259	20				8		L1	160	27
	2-E5	260	8		2-F4	275	63		L4	163	12
	2-E6	261	8				64		L5	164	14
KEY, CLUTCH CENTER	2-E4	259	21	MARK, CONTROL BOX	2-D2	241	11		L12	171	16
KEY, SPECIAL WOODRUFF, 25X18 -	G8	87	16		2-D5	244	12		L14	173	19
KILL UNIT, ENGINE	2-F4	275	45		2-D10	249	17		L16	175	15
KNOB, COCK LEVER	2-F2	273	8	MARK, EMERGENCY SWITCH					M1	176	13
				INDICATION	2-E13	268	22		2-C14	237	31
[L]				MARK, ENGINE KILL SWITCH	2-F4	275	54		2-F4	275	67
LABEL, AIR CLEANER CAUTION ...	2-E12	267	14	MARK, EX. CAUTION	2-E12	267	16	NUT, FLANGE, 8MM	M4	179	17
LABEL, CAUTION	2-E8	263	1		2-E13	268	25				19
	2-E9	264	1		2-F4	275	72		M8	183	13
	2-E13	268	28	MARK, FUEL INDICATION	2-E13	268	18				14
	2-F4	275	62	MARK, OIL ALERT	2-E12	267	10		M12	187	14
LABEL, E-SPEC	2-E14	269	30				11		M14	189	32
			31				12		M16	191	8
LABEL, FUEL CAUTION	2-E13	268	21		2-E13	268	19		N2	193	11
			26				20		N5	196	33
LABEL, FUEL WARNING	2-E10	265	3		2-E14	269	29		N9	200	12
LABEL, FUSE	2-E1	256	8	MARK, OIL CAUTION	2-F4	275	66		2-B1	208	29
LABEL, SPECIFICATION	2-E12	267	9	MARK, OPERATOR CAUTION	2-E12	267	17		2-B3	210	14
LABEL, WARNING	2-E14	269	32		2-E14	269	33		2-F4	275	68
LENS	2-F4	275	50	MARK, REMOTE CONTROL	2-F5	276	73	NUT, HEX., 3MM	J2	129	29
LENS ASSY., PROTECTOR	2-D1	240	13	MARK, THROTTLE INDICATION	2-D13	252	6		L1	160	26
	2-D10	249	16		2-E13	268	24	NUT, HEX., 4MM	2-D1	240	22
	2-F4	275	49	METER ASSY., FUEL	2-F4	275	65		2-D3	242	14
LEVER COMP., CHOKE	I16	127	22		N11	202	7		2-D6	245	19
	K2	145	16		2-B4	211	20		2-D12	251	25
	K14	157	18	METER COMP., FUEL	N7	198	7	NUT, HEX., 5MM	M9	184	27
	L2	161	9	MOTOR UNIT, STARTER	2-B15	222	2		M14	189	25
LEVER COMP., SOLENOID THROTTLE	2-D15	254	5	MUFFLER COMP.	M2	177	1	NUT, HEX., 8MM	M15	190	8
LEVER, CHOKE	J4	131	19		M5	180	1	NUT, PIVOT ADJUSTING	H10	105	15
LEVER, CHOKE SOLENOID	J1	128	22		M11	186	1	NUT, RING	N3	194	11
	K16	159	18		M15	190	1		2-B4	211	7
LEVER, COCK	I15	126	13		M16	191	1	NUT, SELF-LOCK, 6MM	2-C13	236	26
	K2	145	17		N1	192	1	NUT, SPECIAL, 16MM	2-B6	213	13
	K14	157	19		N2	193	15		2-B7	214	13
LEVER, CONTROL	2-C7	230	11	[N]					2-B8	215	13
LEVER, SIDE CLUTCH	2-F10	281	4	NOSE, SILENCER	L8	167	7	NUT, TOOL BOX SETTING	L4	163	10
LIFTER, VALVE	H9	104	4		M1	176	6		L5	164	12
				NOZZLE, MAIN	I14	125	9		L10	169	14
[M]					J1	128	13		L14	173	17
MARK A, COMBINATION	2-E8	263	1		J4	131	11		M1	176	10
MARK B, COMBINATION	2-E10	265	6		J14	141	10	[O]			
MARK, AIR CLEANER	2-E12	267	13		K13	156	11	OIL SEAL	2-E4	259	23
	2-F4	275	71		K16	159	11		2-F6	277	16



PART NAME INDEX

2-H 6

Part name	Address	Page	Ref.	Part name	Address	Page	Ref.	Part name	Address	Page	Ref.
OIL SEAL, 15X28X7	2-F6	277	18	PACKING, FUEL FILLER CAP	N16	207	15	PISTON	H5	100	2
OIL SEAL, 30X45X8	F10	73	16		2-B2	209	33		H6	101	7
OIL SEAL, 30X46X8	E14	61	10				35	PIVOT, ROCKER ARM	H9	104	5
	F10	73	16		2-B3	210	7	PLATE A, FRICTION	I5	116	7
	G3	82	25		2-B4	211	23	PLATE B, FRICTION	I5	116	8
	G5	84	13	PACKING, FUEL STRAINER CUP	J15	142	11	PLATE COMP., CLUTCH PRESSURE	2-E3	258	7
	2-E4	259	22		K14	157	13	PLATE, BATTERY SETTING	2-E2	257	2
	2-E6	261	9		N11	202	1	PLATE, CLUTCH	2-E3	258	6
	2-E7	262	10	PACKING, HEAD COVER	E2	49	7	PLATE, COOLING FAN SETTING	2-B5	212	3
OIL SEAL, 30X50X7	2-E4	259	23	PACKING, INSULATOR	I14	125	12	PLATE, COUPLER SETTING	2-D13	252	3
OIL SEAL, 8X14X5	E14	61	11		J1	128	19	PLATE, EMBLEM	2-E9	264	2
O-RING	N11	202	4		J4	131	15	PLATE, FUEL INDICATION	2-E13	268	20
O-RING, 14MM	E14	61	12		K1	144	15	PLATE, FUEL TANK HANGER	2-B4	211	14
	N4	195	31		K14	157	17	PLATE, GUIDE	I5	116	6
	N9	200	11		K16	159	14	PLATE, LEVER SETTING	I15	126	14
	N16	207	26	PACKING, OIL FILLER CAP	L2	161	8		K3	146	18
	2-B3	210	13		F5	68	7		K14	157	20
O-RING, 16MM	2-F6	277	19		F14	77	7	PLATE, L. SIDE CLUTCH	2-F6	277	6
O-RING, 26X2.7	G5	84	14		F15	78	7	PLATE, PUSH ROD GUIDE	H10	105	13
	2-E4	259	24		G1	80	8	PLATE, R. SIDE CLUTCH	2-F6	277	5
O-RING, 42.5X3	2-F9	280	6	PACKING, REDUCTION COVER	2-E3	258	3	PLATE, SET	M9	184	24
				PACKING, TRANSMISSION CASE	2-F6	277	4		M13	188	22
[P]				PANEL COMP., CONTROL	2-C16	239	5	PLUG, SEALING	E13	60	9
					2-D2	241	4	PLUG, SEAL, 31X5	2-F6	277	17
PACKING	2-C1	224	15		2-D4	243	4	PLUG, SPARK	E6	53	19
PACKING C, FUEL METER	N7	198	12		2-D9	248	7		E7	54	19
PACKING, AIR CLEANER	J2	129	28	PANEL, CONTROL BOX	2-D1	240	14		E8	55	19
	J5	132	24		2-D10	249	17		E9	56	19
	K16	159	24	PAN, CLEANER OIL	L5	164	6		2-F3	274	29
PACKING, AIR CLEANER COVER ...	L13	172	4	PIECE, INTERLOCK	2-F6	277	9	PLUG, USELESS HOLE	I10	121	13
PACKING, CARBURETOR	I14	125	11	PINION, BEVEL	2-F9	280	3		I12	123	20
	J1	128	18	PIN, AUXILIARY CHANGE LEVER ...	2-F8	279	13	PROTECTOR COMP., FAN COVER	I8	119	4
	J4	131	14	PIN, FORK	2-F8	279	6		I13	124	5
	J16	143	14	PIN, GOVERNOR WEIGHT	F8	71	11	PROTECTOR COMP., MUFFLER	M5	180	2
	K14	157	16		F14	77	11		M11	186	2
	K16	159	13		F15	78	11	PROTECTOR, CIRCUIT	2-D1	240	12
	L2	161	7		G2	81	13		2-D10	249	15
PACKING, CASE COVER	F2	65	2	PIN, LOCK, 10MM	G4	83	8		2-F4	275	48
	F14	77	3	PIN, LOCK, 8MM	E16	63	14	PROTECTOR, EX. PIPE	M6	181	3
	F15	78	2		E15	62	14		M11	186	3
	F16	79	2		2-B3	210	15	PROTECTOR, L. MUFFLER	M2	177	6
	G4	83	3		2-E16	271	17	PROTECTOR, MUFFLER INNER	M16	191	2
PACKING, CHAIN CASE COVER	2-E5	260	2	PIN, PISTON	H5	100	3		N1	192	3
	2-E7	262	2	PIN, ROLLER ARM, 8X22	2-E16	271	16	PROTECTOR, MUFFLER OUTER	N1	192	2
PACKING, ELBOW	L5	164	1	PIN, SIDE CLUTCH ARM	2-F10	281	8	PROTECTOR, R. MUFFLER	M2	177	3
	L6	165	1	PIN, SPRING, 2X12	I16	127	23	PULLEY COMP., STARTER	2-B5	212	4
	L13	172	1		K6	149	23	PULLEY, RECOIL STARTER	H14	109	3
	M1	176	1		K14	157	25	PULLEY, STARTER	2-B5	212	5
PACKING, FUEL COCK	I15	126	16		L2	161	11		2-B6	213	6
	K4	147	20	PIPE COMP., EX.	M15	190	2	[R]			
	K14	157	22	PIPE, BOX WRENCH EXTENSION	2-E16	271	15	RATCHET, STARTER	H14	109	4
PACKING, FUEL FILLER CAP	N4	195	23	PIPE, EX.	M2	177	7		I5	116	4
					M6	181	4	RECTIFIER ASSY., REGULATOR	2-C16	239	1
	N6	197	41		M11	186	4		2-D2	241	5
	N7	198	13		M16	191	3		2-D4	243	5
	N9	200	6	PISTON	N1	192	5		2-D5	244	5
	N10	201	16		H2	97	2		2-D7	246	2
					H3	98	2				
	N12	203	10		H4	99	2				

4

PART NAME INDEX

2-H 7

Part name	Address	Page	Ref.	Part name	Address	Page	Ref.	Part name	Address	Page	Ref.
RECTIFIER ASSY., REGULATOR ...	2-F3	274	31	SCREW-WASHER, 5X12	J6	133	38	SCREW, PAN, 5X8	2-D16	255	9
RECTIFIER ASSY., SILICON	2-C16	239	6		L1	160	25	SCREW, PAN, 6X12	M16	191	7
	2-D9	248	8		M9	184	28	SCREW, PAN, 6X6	M16	191	6
	2-D13	252	9		M14	189	26	SCREW, RECESSED, 5X25	2-C13	236	25
	2-F4	275	39	SCREW-WASHER, 5X16	2-C15	238	36		2-C14	237	34
	2-F10	281	1	SCREW-WASHER, 5X32	2-C1	224	16	SCREW, SPECIAL, 6X12	2-D1	240	16
RECTIFIER COMP., REGULATOR ...	I9	120	8	SCREW-WASHER, 6X20	M9	184	29		2-D3	242	12
RECTIFIER COMP., SILICON	2-E1	256	3		M14	189	27		2-D6	245	14
REEL COMP., STARTER	I5	116	3	SCREW SET	I14	125	6		2-D11	250	19
RETAINER, EX. VALVE SPRING ...	H10	105	11		J1	128	8	SCREW, TAPPING, 3X12	2-F4	275	57
RETAINER, IN. VALVE SPRING ...	H10	105	10		J3	130	7	SCREW, TAPPING, 4X6	M4	179	15
			11		J12	139	6				18
RETAINER, SPRING	I1	112	8		K12	155	29		M8	183	12
RING SET, PISTON	G9	88	1		K13	156	7		M9	184	17
	G10	89	1		K16	159	7		M12	187	12
	G11	90	1	SCREW SET, DRAIN	J1	128	7		M14	189	31
	G12	91	1		J3	130	6	SCREW, TAPPING, 4X8	N1	192	10
	G13	92	1		K10	153	26	SCREW, TAPPING, 5X25	M9	184	26
	G14	93	1		K13	156	6		M14	189	24
	G15	94	1		K16	159	6	SCREW, TAPPING, 5X8	M3	178	14
	G16	95	1	SCREW SET, PILOT	I14	125	5				15
	H1	96	1		J1	128	6		M8	183	11
	H2	97	1		J3	130	5				16
ROD ASSY., CONNECTING	H5	100	4		J8	135	53				17
	H6	101	4		J11	138	5		M10	185	32
ROD, CHOKE	J4	131	21		K12	155	29		M12	187	11
ROD, CHOKE CONTROL	J5	132	26		K13	156	5		M14	189	30
	J8	135	54		K16	159	5				31
ROD, CHOKE SOLENOID	J1	128	24	SCREW, CENTER	I4	115	13	SCREW, TAPPING, 6X10	M12	187	13
	K16	159	20	SCREW, FLAT, 5X10	N5	196	32	SCREW, THROTTLE STOP	I14	125	8
ROD, GOVERNOR	2-C3	226	3		N12	203	19		J1	128	11
	2-C4	227	3		N16	207	28		J4	131	9
ROD, PUSH	H8	103	2		2-B4	211	24		J14	141	9
ROPE, RECOIL STARTER	I2	113	11	SCREW, GLOVE BOX	2-F2	273	12		K13	156	10
ROPE, STARTER	I5	116	13	SCREW, LOCK PAN	2-C14	237	29		K16	159	9
	2-B6	213	8	SCREW, PAN, 3X12	2-D1	240	20		L2	161	3
ROTATOR, VALVE	H10	105	12		2-D11	250	23	SCROLL, GENERATOR FAN	I13	124	1
RUBBER, BOTTOM	F1	64	19	SCREW, PAN, 3X6	I15	126	17	SEAL, AIR CLEANER	L16	175	10
			20		K5	148	22	SEAL, CHOKE LEVER	J6	133	33
RUBBER, CONTROL	2-F2	273	3		K14	157	24	SEAL, FUEL FILLER NECK	N7	198	10
RUBBER, CONTROL BOX	2-F3	274	14	SCREW, PAN, 3X8	I15	126	17		2-B4	211	11
RUBBER, FUEL	N12	203	17		K5	148	22	SEAL, MUFFLER DUCT	M15	190	4
RUBBER, SUPPORTER	N3	194	5		K14	157	24				5
	N7	198	3	SCREW, PAN, 4X12	2-D1	240	21				6
	N8	199	1		2-D3	242	13	SEAL, MUFFLER PROTECTOR	N1	192	4
	N13	204	2		2-D6	245	18	SEAL, UNDER AIR GUIDE	2-F3	274	25
	2-B3	210	1		2-D11	250	24	SEAL, VALVE STEM	H10	105	16
RUBBER, TANK CUSHION	N12	203	16	SCREW, PAN, 4X6	2-C14	237	28	SEAT, VALVE SPRING	E2	49	8
	2-B3	210	11		2-C15	238	40	SEPARATOR, AIR CLEANER	L15	174	3
RUBBER, TANK MOUNTING	N12	203	12	SCREW, PAN, 5X12	J6	133	37	SHAFT COMP., P.T.O.	2-E4	259	15
				SCREW, PAN, 5X16	2-C14	237	30	SHAFT COMP., SHIFT FORK	2-F7	278	10
					2-F4	275	56	SHAFT, AUXILIARY	2-F7	278	5
[s]							60	SHAFT, GOVERNOR ARM	E12	59	3
SCREEN SET	2-B3	210	3	SCREW, PAN, 5X16.5	L13	172	13	SHAFT, INPUT	2-F7	278	1
SCREEN, FUEL STRAINER	N11	202	3	SCREW, PAN, 5X28	2-C14	237	29	SHAFT, JOINT	2-F9	280	2
SCREW-WASHER, 3X10	2-D14	253	26		2-C15	238	41	SHAFT, P.T.O.	2-E5	260	5
SCREW-WASHER, 4X6	2-B16	223	14				42		2-E7	262	5
SCREW-WASHER, 4X8	2-D14	253	25	SCREW, PAN, 5X32	I13	124	10	SHAFT, RATCHET	I5	116	5
SCREW-WASHER, 5X10	2-D14	253	27	SCREW, PAN, 5X35	2-C15	238	42	SHAFT, SHIFT	2-F7	278	13

4

PART NAME INDEX

2-H 8

Part name	Address	Page	Ref.	Part name	Address	Page	Ref.	Part name	Address	Page	Ref.
SHAFT, SIDE CLUTCH	2-F8	279	1	SPROCKET COMP., DRIVE	2-E3	258	13	TANK ASSY., FUEL	N14	205	9
SHAFT, SIDE CLUTCH ARM	2-F8	279	8	SPROCKET, DRIVE	2-E5	260	4	TANK ASSY., OIL	2-F10	281	5
SHAFT, WHEEL	2-F6	277	11	STARTER ASSY., RECOIL	H11	106	1	TANK COMP., FUEL	N4	195	20
SHIM A	2-E7	262	6		H12	107	1		N7	198	9
SHIM B	2-E7	262	7		I5	116	1		N8	199	3
SHROUD	I9	120	5	STAY ASSY., CHOKE CONTROL	2-C11	234	18		N11	202	8
SHROUD ASSY., UPPER	I13	124	3	STAY ASSY., MANUAL CHOKE	J4	131	17		N14	205	11
SHROUD COMP., LOWER	I13	124	6	STAY ASSY., SOLENOID	J1	128	20		N15	206	11
SLIDER, GOVERNOR	F8	71	12		K16	159	16		2-B3	210	4
	F14	77	12	STAY A, MUFFLER	N1	192	8		2-B4	211	21
	F15	78	12	STAY COMP., CHOKE SOLENOID	J1	128	21	TERMINAL ASSY., HIGH TENSION..	2-B10	217	2
	G2	81	14		K16	159	17	TIMER UNIT	2-E1	256	7
	G4	83	9	STAY COMP., SOLENOID	J4	131	18	TOOL KIT	2-E15	270	6
SLIDER, SHIFT	2-F7	278	11	STAY, AIR CLEANER	L15	174	5		2-F1	272	5
SOLENOID ASSY.	2-D15	254	6	STAY, CORD CLIP	2-D13	252	13	TUBE ASSY., COCK-CARBURETOR ...	N7	198	2
SOLENOID ASSY., CHOKE	J1	128	25	STAY, MUFFLER COVER	M9	184	23	TUBE, 11X100	E5	52	17
	K16	159	21		M13	188	21	TUBE, 11X105	E4	51	17
SOLENOID, ROTARY CHOKE	J1	128	27	STAY, RECOIL	I5	116	14	TUBE, 3.5X130	J7	134	46
	K16	159	23	STAY, SOLENOID THROTTLE	2-D15	254	4	TUBE, 3.5X30	J7	134	46
SPACER COMP., CARBURETOR	I16	127	21	STOPPER, CHOKE ROD	J5	132	22	TUBE, 3.5X495	J6	133	45
	J16	143	13	STOPPER, DISCHARGE GUARD	M12	203	13	TUBE, 3.5X65	J6	133	45
	K14	157	15	STRAINER COMP., FUEL	N7	198	4	TUBE, 3.5X695	J8	135	52
	L2	161	6	STRAINER, FUEL	2-B4	211	6	TUBE, BATTERY BREATHER	2-E2	257	1
SPACER, CHOKE SOLENOID	J1	128	26	STRAP, CABLE, 118MM	2-D1	240	18	TUBE, BREATHER	E5	52	17
	K16	159	22		2-D3	242	18		L15	174	1
SPACER, CONTROL LEVER	2-C8	231	12		2-D6	245	16	TUBE, CORD	2-D13	252	22
	2-C10	233	15		2-D11	250	21		2-F3	274	15
SPACER, EX. PIPE	M2	177	2		2-F4	275	35	TUBE, FASTENER, 30MM	2-D1	240	19
SPACER, MUFFLER COVER	M9	184	25	STRAP, WIRE HARNESS, 25MM	2-E1	256	10		2-D3	242	19
	M13	188	23		2-F3	274	27		2-D6	245	17
SPANNER, 10X12	2-E16	271	20	SUB EMBLEM	2-E12	267	9		2-D11	250	22
	2-F1	272	9	SUB HARNESS	E12	59	4		2-F4	275	36
SPANNER, 10X14	2-E16	271	21		I10	121	9	TUBE, FUEL	N3	194	3
SPANNER, 14X17	2-E16	271	22		2-D2	241	7		2-B4	211	1
SPRING, BALL SETTING	2-F6	277	8		2-D5	244	7				2
SPRING, BRUSH RETURN	2-B16	223	10		2-D9	248	11				3
SPRING, CABLE RETURN	2-C12	235	19	SUPPORTER, FUEL TUBE	N3	194	6	TUBE, FUEL SUPPORTER	2-B4	211	4
SPRING, CHOKE RETURN	2-D15	254	2	SUSPENSION, COUPLER	2-C16	239	8	TUBE, FUEL TANK	N7	198	1
SPRING, CLUTCH FREE	2-E3	258	8		2-D9	248	10	TUBE, FUEL TANK AUTO FUEL COCK	N3	194	2
SPRING, COCK LEVER	I15	126	15	SUSPENSION, STRAINER	N7	198	5	TUBE, FUEL, 4.5X150	N12	203	20
	K4	147	19	SUSPENSION, WINKER RELAY	2-E1	256	6	TUBE, FUEL, 4.5X165	N12	203	20
	K14	157	21	SWITCH ASSY., COMBINATION	I10	121	10	TUBE, FUEL, 4.5X180	N12	203	20
SPRING, COIL	2-F4	275	52		2-C16	239	10	TUBE, FUEL, 4.5X190	N12	203	20
SPRING, CONTROL ADJUSTING	I13	124	2		2-D2	241	9	TUBE, FUEL, 4.5X222	N5	196	35
	2-C11	234	17		2-D5	244	9		N9	200	13
	2-C14	237	32		2-D10	249	13		2-B1	208	30
SPRING, FRICTION	H15	110	5		2-F4	275	41	TUBE, FUEL, 4.5X260	N12	203	20
	I5	116	10		2-F10	281	2	TUBE, FUEL, 4.5X430	2-B3	210	16
SPRING, GOVERNOR	2-C4	227	4	SWITCH ASSY., ENGINE KILL	2-F2	273	10	TUBE, STRAINER CARBURETOR	N3	194	4
SPRING, LEVER	2-C8	231	12	SWITCH ASSY., ENGINE STOP	I10	121	12	TUBE, VINYL, 4.5X8X230	L16	175	18
SPRING, MANUAL CHOKE	J5	132	23		I12	123	21	TUBE, VINYL, 4.5X8X380	L16	175	19
SPRING, RATCHET	H16	111	7	SWITCH ASSY., OIL LEVEL	E12	59	2				
SPRING, RETURN	I5	116	11	SWITCH ASSY., ONE PUSH KILL ...	2-F4	275	44	[V]			
	2-C12	235	22	SWITCH, THERMO	E2	49	9	VALVE ASSY., SOLENOID	J4	131	16
SPRING, SIDE CLUTCH	2-F8	279	7						J8	135	50
SPRING, STARTER RETURN	H16	111	6	[T]					K16	159	15
SPRING, THROTTLE RETURN	2-C5	228	5	TANK ASSY., FUEL	N3	194	18	VALVE SET, FLOAT	I14	125	2
SPRING, VALVE	H10	105	9		N4	195	18		J1	128	2
SPRING, WEIGHT RETURN	H9	104	6								

PART NAME INDEX

Part name	Address	Page	Ref.	Part name	Address	Page	Ref.	Part name	Address	Page	Ref.
VALVE SET, FLOAT	J3	130	2	WASHER, SPRING, 8MM	2-E4	259	28				
	J10	137	2	WASHER, TANK CUSHION	N12	203	15				
	K13	156	2	WASHER, THRUST, 17MM	2-F7	278	18				
	K16	159	2	WASHER, THRUST, 20MM	2-F7	278	17				
VALVE, DASHPOT CHECK	J5	132	29	WASHER, THRUST, 25MM	2-E4	259	18				
	L2	161	10	WASHER, THRUST, 2.7X8	J6	133	34				
VALVE, EX.	H9	104	8	WATER SEAL, 25X52X9.5	2-F6	277	15				
	H10	105	8	WEIGHT, BALANCER	G7	86	7				
VALVE, IN.	H9	104	7	WEIGHT, CLUTCH	2-E3	258	10				
				WEIGHT, GOVERNOR	F6	69	9				
[W]					F14	77	9				
WASHER COMP., HEAD COVER	E4	51	14		F15	78	9				
WASHER, 10.5X40X4	2-E5	260	7		G2	81	11				
WASHER, 11.7MM	G8	87	14		G4	83	6				
WASHER, 6X16	F9	72	14	WIRE, WATER COVER	2-B16	223	12				
	F14	77	14		2-C2	225	20				
	F15	78	14	WRENCH COMP., SPARK PLUG	2-E16	271	13				
	G2	81	15	WRENCH, BOX	2-E15	270	12				
	G5	84	10		2-E16	271	23				
WASHER, 8MM	2-E5	260	6		2-F1	272	12				
	2-E7	262	8	WRENCH, PLUG	2-E15	270	11				
WASHER, 8.2X17X0.8	E12	59	7		2-F1	272	7				
WASHER, AIR DUCT	2-B3	210	12	[Y]							
	2-F3	274	13	YOKE COMP.	2-B16	223	8				
WASHER, BEVEL GEAR	2-F9	280	4								
WASHER, CHOKE LEVER	J6	133	32								
WASHER, CLUTCH SPRING	2-F8	279	12								
WASHER, CONICAL SPRING, 6MM ..	2-F8	279	11								
WASHER, CONICAL SPRING, 8MM ..	2-F7	278	16								
WASHER, CONTROL LEVER	2-C8	231	13								
WASHER, DRAIN PLUG, 12MM	E12	59	8								
	2-E4	259	27								
WASHER, LOCK, 8MM	G8	87	15								
	2-E4	259	19								
	2-E5	260	7								
	2-F10	281	7								
WASHER, PLAIN, 10MM	I6	117	18								
WASHER, PLAIN, 4MM	2-D6	245	23								
	2-D12	251	29								
WASHER, PLAIN, 5MM	J6	133	40								
	M9	184	30								
	M14	189	28								
WASHER, PLAIN, 6MM	F11	74	17								
	F14	77	16								
	F15	78	16								
	G2	81	18								
	G5	84	15								
	I6	117	20								
WASHER, PLAIN, 8MM	N5	196	39								
WASHER, SEALING, 8MM	2-F6	277	14								
WASHER, SPRING, 3MM	J2	129	30								
	L1	160	28								
WASHER, SPRING, 4MM	2-D1	240	23								
	2-D3	242	15								
	2-D6	245	20								
	2-D12	251	26								
WASHER, SPRING, 5MM	M10	185	31								
	M14	189	29								



1

FOREWORD INDEX

2

ENGINE GROUP

3

PART NUMBER INDEX

4

PART NAME INDEX

HONDA
The Power of Dreams



PARTS CATALOGUE NEWS

Honda Motor Co., Ltd. Service Division

PARTS CATALOGUE - CORRECTED

Printed in Japan

CODE NO.	BOOKLET TYPE	17ZE20E8
	MICRO- FICHE	17ZE20EG/FG/GG
PARTS CATALOGUE NEWS	GX240K1 GX240K1[PROPANE ENGINE]	
NEWS NO.	001	

Block No.	Ref. No.	Note	Part No.	Description	Reqd. QTY			Serial No.	Parts catalogue code
					(1)	(2)	(3)		
E-7	6		13320-ZE2-671	CRANKSHAFT COMP.	1	-	-	-----	VA, VAH1, VA2, VH12, VTA, VTA2, VWC2
					1	-	-	-----	4773271 VA2/A, VH12/A, VMT2, VTA2/A, VWC2/A
			A	13320-ZE2-672	1	-	-	4773272
E-23-2	5		31620-ZG5-023	RECTIFIER ASSY., REGULATOR (20A)	-	(1)	-	4845215 4865121	L1/A, Q1/A, R1/A, S1/A, W1/A
					A	31620-ZG5-033	-	(1)

NOTE A:PART NO. CHANGE D:NEWLY PROVIDED E:PART NO.DELETION K:REQUIRED NO. CORRECTION L:APPLICATION SERIAL NO. CORRECTION
T:APPLICATION CORRECTION Z:REMARKS CHANGE



PARTS CATALOGUE NEWS

Honda Motor Co., Ltd. Service Division

PARTS CATALOGUE - CORRECTED

Printed in Japan

CODE NO.	17ZE20E8
PARTS CATALOGUE NEWS	GX240K1 GX240K1[PROPANE ENGINE]
NEWS NO.	002

Block No.	Ref. No.	Note	Part No.	Description	Reqd. QTY			Serial No.	Parts catalogue code
					(1)	(2)	(3)		
E-40	41	T	35100-ZB4-013	SWITCH ASSY., COMBINATION	1	-	-	-----	EDS, EDS1, EDS2, EDS2/A, EDS3, EDS6, EDS6/A
		D	35100-ZB4-023	1	-	-	-----	EDS1/A

NOTE A:PART NO. CHANGE D:NEWLY PROVIDED E:PART NO.DELETION K:REQUIRED NO. CORRECTION L:APPLICATION SERIAL NO. CORRECTION
T:APPLICATION CORRECTION Z:REMARKS CHANGE



PARTS CATALOGUE NEWS

Honda Motor Co., Ltd. Service Division

PARTS CATALOGUE - CORRECTED

Printed in Japan

CODE NO.	17ZE20E8
PARTS CATALOGUE NEWS	GX240K1 GX240K1[PROPANE ENGINE]
NEWS NO.	003

Block No.	Ref. No.	Note	Part No.	Description	Reqd. QTY			Serial No.	Parts catalogue code					
					(1)	(2)	(3)							
E-28	12	L	87532-ZH8-000	MARK, OIL ALERT	1	(1)	-	----- 4883722	LSX/A, LXF, L1/A, Q1/A, R1/A, SJC1/A, SJC5/A, SMS/A, SNR/A S1/A, W1/A					
					1	(1)	-	3116815	-----	L1, P1, Q1, R1, SJP, SNR, S1, V1, W1				
					1	-	-	-----	-----	LSX, SJC1, SJC5, SMS				
					1	-	-	-----	-----	ED5, ED5/A, HAQ, HA2, LX2, LX2/A, PAE, PA2, PMT2, PMT2/A, QAB2 QAB2/A, QAE2, QAE2/A, QAG, QAG/A, QAG2, QAG2/A, QAQ, QAR2 QAR2/A, QA2, QA2/A, QKA2, QMX2, QTC2, QTC2/A, QXC9, QXC9/A QXU, QXU/A, RA2, RSC2, RTB2, RTB2/A, SMX2, SMX2/A, SXU, SXU/A VA2, VA2/A, VDG2, VDG2/A, VMX, VTA, VTA2, VTA2/A, VWC2, VXB/A VXEB/A, VXU, VXU/A, VXU1, VXU1/A, WKD6, WKD6/A, WKT2, WKT2/A				
						87532-ZH8-810	MARK, OIL ALERT (ENGLISH)	1	-	-	-----	-----	ED5, ED5/A, HAQ, HA2, LX2, LX2/A, PAE, PA2, PMT2, PMT2/A, QAB2 QAB2/A, QAE2, QAE2/A, QAG, QAG/A, QAG2, QAG2/A, QAQ, QAR2 QAR2/A, QA2, QA2/A, QKA2, QMX2, QTC2, QTC2/A, QXC9, QXC9/A QXU, QXU/A, RA2, RSC2, RTB2, RTB2/A, SMX2, SMX2/A, SXU, SXU/A VA2, VA2/A, VDG2, VDG2/A, VMX, VTA, VTA2, VTA2/A, VWC2, VXB/A VXEB/A, VXU, VXU/A, VXU1, VXU1/A, WKD6, WKD6/A, WKT2, WKT2/A	
								1	-	-	-----	4734391	HA2/A, PA2/A, RA2/A	
								1	-	-	-----	4882109	ES1/A, ES2, HX/A, LX/A, PX/A, QX/A, QXC/A, QXE/A, RX/A, SX/A VX/A, VXE/A	
								1	-	-	-----	3116815	ES1, HA, HX, LX, LXZ, PA, PX, QA, QAE, QX, QXC, QXE, QXEB, RA, RX SX, SXE, SXEB, VA, VNG, VX, VXB, VXE, VXEB	
								1	-	-	-----	3116815	3302521	QXB, SXB
					A	87530-ZL8-810	MARK, OIL ALERT	1	(1)	-	----- 4883723	-----	LSX/A, LXF, L1/A, Q1/A, R1/A, SJC1/A, SJC5/A, SMS/A, SNR/A S1/A, W1/A	
		A	87530-ZL8-850	MARK, OIL ALERT (ENGLISH)	1	-	-	----- 4882110	-----	ES1/A, ES2, HX/A, LX/A, PX/A, QX/A, QXC/A, QXE/A, RX/A, SX/A VX/A, VXE/A				

NOTE A:PART NO. CHANGE D:NEWLY PROVIDED E:PART NO. DELETION K:REQUIRED NO. CORRECTION L:APPLICATION SERIAL NO. CORRECTION T:APPLICATION CORRECTION Z:REMARKS CHANGE



PARTS CATALOGUE NEWS

Honda Motor Co., Ltd. Service Division

PARTS CATALOGUE - CORRECTED

Printed in Japan

CODE NO.	17ZE20E8
PARTS CATALOGUE NEWS	GX240K1 GX240K1[PROPANE ENGINE]
NEWS NO.	004

Block No.	Ref. No.	Note	Part No.	Description	Reqd. QTY			Serial No.	Parts catalogue code	
					(1)	(2)	(3)			
E-17-4	11	T	17510-ZE2-010ZA	TANK COMP., FUEL *NH31*..... MCKINLEY WHITE	1	(1)	-	-----	-----	ED4, ED5, ES1, HH, HHQ4, HX, HXQ4, LDB1, LH, LHE4, LP, LT, LW, LX, LXQ4, LXZ, L1, PX, P1, QAB2, QAR2, QC12, QD, QDA, QE, QH, QHC, QHE, QHP1, QHQ4, QKA2, QMH, QP, QT, QTC2, QX, QXB, QXB7, QXE, QXEB, QXE4, QXQ4, QXU, Q1, RD, RH, RHE, RHE4, RHQ4, RTB2, RX, RXQ4, R1, SD, SDB3, SE, SH, SHEZ, SHW, SNC1, SNE1, SW, SWE, SX, SXB, SXE, SXEB, SXE4, SXQ4, SXU, VDG2, VH, VMX, VX, VXB, VXB7, VXE, VXEB, VXQ4, VXQ7, VXU, VXU1, V1, WH, WKD6, WKT4, W1
					1	(1)	-	-----	4568628	ED4/A, ED5/A, ES1/A, HHQ4/A, HX/A, HXQ4/A, LH/A, LHE4/A, LP/A, LT/A, LX/A, LXQ4/A, L1/A, PX/A, QAB2/A, QAR2/A, QC12/A, QD/A, QE/A, QH/A, QHP1/A, QHQ4/A, QMH/A, QP/A, QT/A, QTC2/A, QX/A, QXB7/A, QXE/A, QXE4/A, QXQ4/A, QXU/A, Q1/A, RD/A, RHQ4/A, RTB2/A, RX/A, RXQ4/A, R1/A, SD/A, SDB3/A, SE/A, SX/A, SXE4/A, SXQ4/A, SXU/A, VDG2/A, VH/A, VX/A, VXB/A, VXB7/A, VXE/A, VXEB/A, VXQ4/A, VXQ7/A, VXU/A, VXU1/A, WKD6/A, WKT4/A, W1/A
					1	-	-	-----	4475051	SHW/A
					1	(1)	-	4568629	4776725	ED4/A, ED5/A, ES1/A, HHQ4/A, HX/A, HXQ4/A, LH/A, LHE4/A, LP/A, LT/A, LX/A, LXQ4/A, L1/A, PX/A, QAB2/A, QAR2/A, QC12/A, QD/A, QE/A, QH/A, QHP1/A, QHQ4/A, QMH/A, QP/A, QT/A, QTC2/A, QX/A, QXB7/A, QXE/A, QXE4/A, QXQ4/A, QXU/A, Q1/A, RD/A, RHQ4/A, RTB2/A, RX/A, RXQ4/A, R1/A, SD/A, SDB3/A, SE/A, SX/A, SXE4/A, SXQ4/A, SXU/A, VDG2/A, VH/A, VX/A, VXB/A, VXB7/A, VXE/A, VXEB/A, VXQ4/A, VXQ7/A, VXU/A, VXU1/A, WKD6/A, WKT4/A, W1/A
		T	17510-ZE2-020ZA	*NH31*..... MCKINLEY WHITE	1	(1)	-	-----	-----	ED3, ES, LD, LDB3, LHE, LHZ, LSS4, QAQ4, QHZ, QMX2, SDB1, SHE

NOTE A:PART NO. CHANGE D:NEWLY PROVIDED E:PART NO. DELETION K:REQUIRED NO. CORRECTION L:APPLICATION SERIAL NO. CORRECTION
T:APPLICATION CORRECTION Z:REMARKS CHANGE



PARTS CATALOGUE NEWS

Honda Motor Co., Ltd. Service Division

PARTS CATALOGUE - CORRECTED

Printed in Japan

CODE NO.	17ZE20E8
PARTS CATALOGUE NEWS	GX240K1 GX240K1[PROPANE ENGINE]
NEWS NO.	005

Block No.	Ref. No.	Note	Part No.	Description	Reqd. QTY			Serial No.	Parts catalogue code					
					(1)	(2)	(3)							
E-16-5	1		18310-ZD1-E31	MUFFLER COMP.	1	-	-	-----	EDS, EDS1, EDS2, EDS2/A, EDS3, EDS6, EDS6/A, EDT1, EDT2, EDT6 EDT6/A, ES3, VSB1, VSB1/A					
					1	-	-	-----	3337056	ED2				
					1	-	-	-----	4890237	EDS1/A, EDT1/A, EDT3, ES3/A				
					A	18310-ZD1-E32	1	-	-	4890238	-----	EDS1/A, EDT1/A, EDT3, ES3/A	
					15		18310-ZE2-V60	MUFFLER COMP. (TSURUMI)	1	-	-	-----	ED2/A, EN2, EN2/A, VTE2	
									1	-	-	-----	4888170	VS3, VS4
									1	-	-	3337057	-----	ED2
					A	18310-ZE2-V61	1	-	-	4888171	-----	VS3, VS4	

NOTE A:PART NO. CHANGE D:NEWLY PROVIDED E:PART NO. DELETION K:REQUIRED NO. CORRECTION L:APPLICATION SERIAL NO. CORRECTION
T:APPLICATION CORRECTION Z:REMARKS CHANGE



PARTS CATALOGUE NEWS

Honda Motor Co., Ltd. Service Division

PARTS CATALOGUE - CORRECTED

Printed in Japan

CODE NO.	17ZE20E8
PARTS CATALOGUE NEWS	GX240K1 GX240K1[PROPANE ENGINE]
NEWS NO.	006

Block No.	Ref. No.	Note	Part No.	Description	Reqd. QTY			Serial No.	Parts catalogue code
					(1)	(2)	(3)		
E-16	13	D	18381-Z8S-801	GASKET, MUFFLER (ARRESTER) (THAI LEAKLESS)	-	(1)	-	-----	L1/A, Q1/A, R1/A, S1/A, W1/A
E-16-1	8	D	18381-Z8S-801	GASKET, MUFFLER (ARRESTER) (THAI LEAKLESS)	1	(1)	-	-----	LJS/A, L1/A, Q1/A, R1/A, S1/A, W1/A
E-16-2	8	D	18381-Z8S-801	GASKET, MUFFLER (ARRESTER) (THAI LEAKLESS)	-	(1)	-	-----	L1/A, Q1/A, R1/A, S1/A, W1/A

NOTE A:PART NO. CHANGE D:NEWLY PROVIDED E:PART NO.DELETION K:REQUIRED NO. CORRECTION L:APPLICATION SERIAL NO. CORRECTION
T:APPLICATION CORRECTION Z:REMARKS CHANGE



PARTS CATALOGUE NEWS

Honda Motor Co., Ltd. Service Division

PARTS CATALOGUE - CORRECTED

Printed in Japan

CODE NO.	17ZE20E8
PARTS CATALOGUE NEWS	GX240K1 GX240K1[PROPANE ENGINE]
NEWS NO.	007

Block No.	Ref. No.	Note	Part No.	Description	Reqd. QTY			Serial No.	Parts catalogue code				
					(1)	(2)	(3)						
E-16	3		18320-ZE2-P50	PROTECTOR, R. MUFFLER (SILENT)	1	-	-	-----	-----	PMT2, PMT2/A, WKA			
								1	-	-	3217996	-----	LM9
								(1)	(1)	-	3217996	-----	LD, L1, P1, QD, Q1, RD, R1, SD, S1, V1, W1
								-	(1)	-	4914834	-----	L1/A, Q1/A, R1/A, S1/A, W1/A
							A	18320-ZE2-P51	-	(1)	-	4914835

NOTE A:PART NO. CHANGE D:NEWLY PROVIDED E:PART NO.DELETION K:REQUIRED NO. CORRECTION L:APPLICATION SERIAL NO. CORRECTION
T:APPLICATION CORRECTION Z:REMARKS CHANGE



PARTS CATALOGUE NEWS

Honda Motor Co., Ltd. Service Division

PARTS CATALOGUE - CORRECTED

Printed in Japan

CODE NO.	17ZE20E8
PARTS CATALOGUE NEWS	GX240K1 GX240K1[PROPANE ENGINE]
NEWS NO.	008

Block No.	Ref. No.	Note	Part No.	Description	Reqd. QTY			Serial No.	Parts catalogue code
					(1)	(2)	(3)		
E-3	2		15510-ZE2-053	SWITCH ASSY., OIL LEVEL	1	-	-	----- 4891715	EDT3, ES2, VS4
					1	-	-	4850562 4891715	EDS1/A, EDT1/A, ES1/A, ES3/A, HX/A, LSX/A, LX/A, LXF, PX/A, QX/A, QXC/A, QXE/A, RX/A, SJC1/A, SJC5/A, SMS/A, SNR/A, SX/A, VS3, VX/A, VXE/A
					-	(1)	-	4850562 -----	Q1/A, S1/A, W1/A
	A		35480-ZF6-003	1	-	-	4891716 -----	EDS1/A, EDT1/A, EDT3, ES1/A, ES2, ES3/A, HX/A, LSX/A, LX/A, LXF, PX/A, QX/A, QXC/A, QXE/A, RX/A, SJC1/A, SJC5/A, SMS/A, SNR/A, SX/A, VS3, VS4, VX/A, VXE/A

NOTE A:PART NO. CHANGE D:NEWLY PROVIDED E:PART NO. DELETION K:REQUIRED NO. CORRECTION L:APPLICATION SERIAL NO. CORRECTION
T:APPLICATION CORRECTION Z:REMARKS CHANGE



PARTS CATALOGUE NEWS

Honda Motor Co., Ltd. Service Division

PARTS CATALOGUE - CORRECTED

Printed in Japan

CODE NO.	17ZE20E8
PARTS CATALOGUE NEWS	GX240K1 GX240K1[PROPANE ENGINE]
NEWS NO.	009

Block No.	Ref. No.	Note	Part No.	Description	Reqd. QTY			Serial No.	Parts catalogue code
					(1)	(2)	(3)		
E-11	1		28400-ZE2-W01ZN	STARTER ASSY., RECOIL *R280*.....POWER RED	1	(1)	-	4465233 4914022	EDS1/A, EDT1/A, ES1/A, ES3/A, HX/A, LH/A, LJ/A, LJG/A, LJS/A, LSX/A, LX/A, L1/A, PX/A, QD/A, QH/A, QHP1/A, QP/A, QX/A, QXC/A, QXE/A, Q1/A, RD/A, RJ/A, RX/A, R1/A, SD/A, SJ/A, SJC1/A, SJC5/A, SJG/A, SMS/A, SNR/A, SX/A, S1/A, VX/A, VXE/A, WJ/A, W1/A
					1	-	1	-----	QHB2, VS3, VXP/A
					1	-	-	----- 4914022	EDT3, ES2, LXF, WMK
					1	-	-	4465233 -----	ED2/A, ED4/A, ED5/A, HA2/A, HHQ4/A, HXQ4/A, LHE4/A, LP/A, LSS5/A, LT/A, LXQ4/A, LX2/A, PA2/A, QAB2/A, QAE2/A, QAG/A, QAG2/A, QAR2/A, QA2/A, QC12/A, QE/A, QHQ4/A, QMH/A, QT/A, QTC2/A, QXB7/A, QXC9/A, QXE4/A, QXQ4/A, QXU/A, RA2/A, RHQ4/A, RSS1/A, RTB2/A, RXQ4/A, SDB3/A, SE/A, SMX2/A, STP/A, STQ/A, SXE4/A, SXQ4/A, SXU/A, VA2/A, VDG2/A, VH/A, VH12/A, VSB1/A, VTA2/A, VXB/A, VXB7/A, VXEB/A, VXQ4/A, VXQ7/A, VXU/A, VXU1/A, WKD6/A, WKT2/A, WKT4/A
			28400-ZE2-W01ZB	*NH1*.....BLACK	1	(1)	-	-----	EDN, EDN2, EDN2/A, EDS1, EDS2, EDS2/A, EDS3, EDS6, EDS6/A, EDT1, EDT2, EDT6, EDT6/A, ED2, ED2/A, ED4, ED4/A, ED5, ED5/A, EN2, EN2/A, ES1, ES3, HA2, HA2/A, LX2, LX2/A, PA2, PA2/A, PMT2, PMT2/A, PX, PX/A, QAE2, QAE2/A, QAG, QAG/A, QAQ4, QAR2, QAR2/A, QA2, QA2/A, QMX2, QTC2, QTC2/A, QW24, QXC9, QXC9/A, Q1, RA2, RA2/A, SMX2, SMX2/A, SX, SX/A, SXU, SXU/A, S1, VA2, VA2/A, VS3, VTA2, VTA2/A, VWC2, VWC2/A, VXB7, VXB7/A, VXQ4, VXQ4/A
					1	(1)	-	----- 4914022	EDS1/A, EDT1/A, EDT3, ES1/A, ES2, ES3/A, Q1/A, S1/A
					1	-	-	3139635 -----	HA, QA

NOTE A:PART NO. CHANGE D:NEWLY PROVIDED E:PART NO.DELETION K:REQUIRED NO. CORRECTION L:APPLICATION SERIAL NO. CORRECTION
T:APPLICATION CORRECTION Z:REMARKS CHANGE

PARTS CATALOGUE NEWS

BOOKNo. : 17ZE20E8

Block No.	Ref. No.	Note	Part No.	Description	Reqd. QTY			Serial No.	Parts catalogue code
					(1)	(2)	(3)		
					1	-	-	3187181 -----	HAQ, QAQ
			28400-ZE2-W01ZG	*NH105*... MAT BLACK (#15-#20)	1	-	-	-----	VMT2, VWC2, VWC2/A, VXB7, VXB7/A
					1	-	-	----- 4914022	VS3
			28400-ZE2-W01ZK	*Y131*... LIGHTNING YELLOW	1	-	-	-----	ED2, ED2/A, ES1, ES1/A, ES3, ES3/A, VTE2
					1	-	-	----- 4914022	ES2
			28400-ZE2-W01ZL	*T77*... SEC WINE RED	1	-	-	-----	ES1, ES1/A, ES3
					1	-	-	----- 4914022	ES2, ES3/A
			28400-ZE2-W01ZM	*T80*... BAKELITE ORANGE	1	-	-	-----	ED2, ED2/A, ES1, ES3
					1	-	-	----- 4914022	ES1/A, ES2, ES3/A
		A	28400-ZE2-W02ZN	*R280*... POWER RED	1	(1)	-	4914023 -----	EDS1/A, EDT1/A, EDT3, ES1/A, ES2, ES3/A, HX/A, LH/A, LJ/A, LJV/A, LJS/A, LSX/A, LX/A, LXF, L1/A, PX/A, QD/A, QH/A, QHP1/A, QP/A, QX/A, QXC/A, QXE/A, Q1/A, RD/A, RJ/A, RX/A, R1/A, SD/A, SJ/A, SJC1/A, SJC5/A, SJG/A, SMS/A, SNR/A, SX/A, S1/A, VX/A, VXE/A, WJ/A, WMK, W1/A
		A	28400-ZE2-W02ZB	*NH1*... BLACK	1	(1)	-	4914023 -----	EDS1/A, EDT1/A, EDT3, ES1/A, ES2, ES3/A, Q1/A, S1/A
		A	28400-ZE2-W02ZG	*NH105*... MAT BLACK (#15-#20)	1	-	-	4914023 -----	VS3
		A	28400-ZE2-W02ZK	*Y131*... LIGHTNING YELLOW	1	-	-	4914023 -----	ES2
		A	28400-ZE2-W02ZL	*T77*... SEC WINE RED	1	-	-	4914023 -----	ES2, ES3/A
		A	28400-ZE2-W02ZM	*T80*... BAKELITE ORANGE	1	-	-	4914023 -----	ES1/A, ES2, ES3/A

NOTE A:PART NO. CHANGE D:NEWLY PROVIDED E:PART NO. DELETION K:REQUIRED NO. CORRECTION L:APPLICATION SERIAL NO. CORRECTION
T:APPLICATION CORRECTION Z:REMARKS CHANGE

PARTS CATALOGUE NEWS

BOOKNo. : 17ZE20E8

Block No.	Ref. No.	Note	Part No.	Description	Reqd. QTY			Serial No.	Parts catalogue code
					(1)	(2)	(3)		
	10		28461-ZE2-W02	GRIP, STARTER	1	(1)	-	-----	EDN, EDN2, EDN2/A, EDS, EDS1, EDS2, EDS2/A, EDS3, EDS6, EDS6/A, EDT1, EDT2, EDT6, EDT6/A, ED2, ED2/A, ED3, ED4, ED4/A, ED5, ED5/A, EN, EN2, EN2/A, ES, ES1, ES3, ET, ETS, ETX, HA, HAQ, HA2, HA2/A, HH, HHQ4, HHQ4/A, HTX, HX, HXQ4, HXQ4/A, LD, LDB1, LDB3, LH, LHE, LHE4, LHE4/A, LHZ, LJ, LJG, LJG1, LJS, LK, LN2, LP, LP/A, LSS4, LSS5, LSS5/A, LSX, LT, LT/A, LW, LX, LXQ4, LXQ4/A, LXZ, LX2, LX2/A, L1, PA, PAE, PA2, PA2/A, PMT2, PMT2/A, PX, P1, QA, QAB2, QAB2/A, QAE, QAE2, QAE2/A, QAG, QAG/A, QAG2, QAG2/A, QAQ, QAQ4, QAR2, QAR2/A, QA2, QA2/A, QC12, QC12/A, QD, QDA, QE, QE/A, QH, QHB2, QHC, QHE, QHP1, QHQ4, QHQ4/A, QHZ, QKA2, QMH, QMH/A, QMX2, QP, QT, QT/A, QTC2, QTC2/A, QW24, QX, QXB, QXB7, QXB7/A, QXC, QXC9, QXC9/A, QXE, QXE4, QXE4/A, QXQ4, QXQ4/A, QXU, QXU/A, Q1, RA, RA2, RA2/A, RD, RH, RHE, RHE4, RHQ4, RHQ4/A, RJ, RSC2, RSS1, RTB2, RTB2/A, RX, RXQ4, RXQ4/A, R1, SD, SDB1, SDB3, SDB3/A, SE, SE/A, SH, SHE, SHEZ, SJ, SJC, SJC1, SJC5, SJG, SJP, SK, SMS, SMX2, SMX2/A, SNC1, SNE1, SNR, STP, STP/A, STQ, STQ/A, SW, SWE, SX, SXB, SXE, SXEB, SXE4, SXE4/A, SXQ4, SXQ4/A, SXU, SXU/A, S1, VA, VAH1, VA2, VA2/A, VDG2, VDG2/A, VH, VH/A, VH12, VH12/A, VMT2, VMX, VNG, VSB1, VSB1/A, VTA, VTA2, VTA2/A, VTE2, VWC2, VWC2/A, VX, VXB, VXB/A, VXB7, VXB7/A, VXE, VXEB, VXEB/A, VXQ4, VXQ4/A, VXQ7, VXQ7/A, VXU, VXU/A, VXU1, VXU1/A, V1, WH, WJ, WKA, WKD6, WKD6/A, WKT2, WKT2/A, WKT4, WKT4/A, W1
					1	(1)	-	----- 4914022	EDS1/A, EDT1/A, EDT3, ES1/A, ES2, ES3/A, HX/A, LH/A, LJ/A, LJG/A, LJS/A, LSX/A, LX/A, LXF, L1/A, PX/A, QD/A, QH/A, QHP1/A, QP/A, QX/A, QXC/A, QXE/A, Q1/A, RD/A, RJ/A, RSS1/A, RX/A, R1/A, SD/A, SJ/A, SJC1/A, SJC5/A, SJG/A, SMS/A, SNR/A, SX/A, S1/A, VS3, VS4, VX/A, VXE/A, WJ/A, WMK, W1/A
					-	-	1		
	A		28461-ZE2-W03	1	(1)	-	4914023 -----	EDS1/A, EDT1/A, EDT3, ES1/A, ES2, ES3/A, HX/A, LH/A, LJ/A, LJG/A, LJS/A, LSX/A, LX/A, LXF, L1/A, PX/A, QD/A, QH/A, QHP1/A, QP/A, QX/A, QXC/A, QXE/A, Q1/A, RD/A, RJ/A, RSS1/A, RX/A, R1/A, SD/A, SJ/A, SJC1/A, SJC5/A, SJG/A, SMS/A, SNR/A, SX/A, S1/A, VS3, VS4, VX/A, VXE/A, WJ/A, WMK, W1/A

NOTE A:PART NO. CHANGE D:NEWLY PROVIDED E:PART NO.DELETION K:REQUIRED NO. CORRECTION L:APPLICATION SERIAL NO. CORRECTION
T:APPLICATION CORRECTION Z:REMARKS CHANGE