

en **Parts Manual**  
**MAXI-AIR™ 100**



[www.discount-equipment.com](http://www.discount-equipment.com)

# PARTS FINDER

**Search Website  
by Part Number**



**Search Manual  
Library For Parts  
Manual & Lookup Part  
Numbers – Purchase  
or Request Quote**

**Search Manuals**

Enter your information to help us find the right parts manual for your machine.

\* Brand:

\* Model:

\* Serial:

\* Part Number:

SEARCH

**Can't Find Part or  
Manual? Request Help  
by Manufacturer,  
Model & Description**

**Parts Order Form**

Please fill in the following information to help us find the right part for your machine.

Manufacturer:	<input type="text"/>
Model:	<input type="text"/>
Description:	<input type="text"/>
Part Number:	<input type="text"/>
Quantity:	<input type="text"/>
Notes:	<input type="text"/>

Submit

Discount-Equipment.com is your online resource for quality parts & equipment.

Florida: **561-964-4949** Outside Florida TOLL FREE: **877-690-3101**

**Need parts?**

Click on this link: <http://www.discount-equipment.com/category/5443-parts/> and choose one of the options to help get the right parts and equipment you are looking for. Please have the machine model and serial number available in order to help us get you the correct parts. If you don't find the part on the website or on one of the online manuals, please fill out the request form and one of our experienced staff members will get back to you with a quote for the right part that your machine needs.

We sell worldwide for the brands: Genie, Terex, JLG, MultiQuip, Mikasa, Essick, Whiteman, Mayco, Toro Stone, Diamond Products, Generac Magnum, Airman, Haulotte, Barreto, Power Blanket, Nifty Lift, Atlas Copco, Chicago Pneumatic, Allmand, Miller Curber, Skyjack, Lull, Skytrak, Tsurumi, Husquvarna Target, Stow, Wacker, Sakai, Mi-T-M, Sullair, Basic, Dynapac, MBW, Weber, Bartell, Bennar Newman, Haulotte, Ditch Runner, Menegotti, Morrison, Contec, Buddy, Crown, Edco, Wyco, Bomag, Laymor, EZ Trench, Bil-Jax, F.S. Curtis, Gehl Pavers, Heli, Honda, ICS/PowerGrit, IHI, Partner, Imer, Clipper, MMD, Koshin, Rice, CH&E, General Equipment, Amida, Coleman, NAC, Gradall, Square Shooter, Kent, Stanley, Tamco, Toku, Hatz, Kohler, Robin, Wisconsin, Northrock, Oztec, Toker TK, Rol-Air, APT, Wylie, Ingersoll Rand / Doosan, Innovatech, Con X, Ammann, Mecalac, Makinex, Smith Surface Prep, Small Line, Wanco, Yanmar

## TABLE OF CONTENTS

### 1.0 TRAILER PARTS GROUP

Axle and Wheel Group .....	(1.1)
Tongue Group .....	(1.2)
Tongue Coupler Options .....	(1.3)
Front and Top Enclosure Panels .....	(1.4)
Left Enclosure Panels and Door .....	(1.5)
Right Enclosure Panels and Door .....	(1.6)
Rear Enclosure Panels .....	(1.7)

### 2.0 ENGINE GROUP

Maxi-Air 100 Engine and Mounting .....	(2.1)
Engine Finger and Fan Guards .....	(2.2)
Engine Cooling Group .....	(2.3)
Engine Air Intake Group .....	(2.4)
Engine Exhaust Group .....	(2.5)
Fuel Tank and Fuel Lines .....	(2.6)

### 3.0 AIR COMPRESSOR GROUP

Air End .....	(3.1)
Unloader .....	(3.2)
Receiver, Separator, and Service Header .....	(3.3)
Air Lines .....	(3.4)
Oil Lines .....	(3.5)

### 4.0 ELECTRICAL GROUP

Control Box Group .....	(4.1)
Battery Cables Group .....	(4.2)
Battery Charger .....	(4.3)
Trailer Lighting .....	(4.4)
Trailerless Lighting Hole Covers .....	(4.5)

# Maxi-Air 100

## TABLE OF CONTENTS

### 5.0 DECALS

Left and Right Side Enclosure Decals .....	(5.1)
Top, Front, and Rear Side Enclosure Decals .....	(5.2)
Tongue and Finger Guard Decals .....	(5.3)
Other Interior Decals .....	(5.4)

Go to [Discount-Equipment.com](http://Discount-Equipment.com) to order your parts

## 1.1 - Axle and Wheel Group

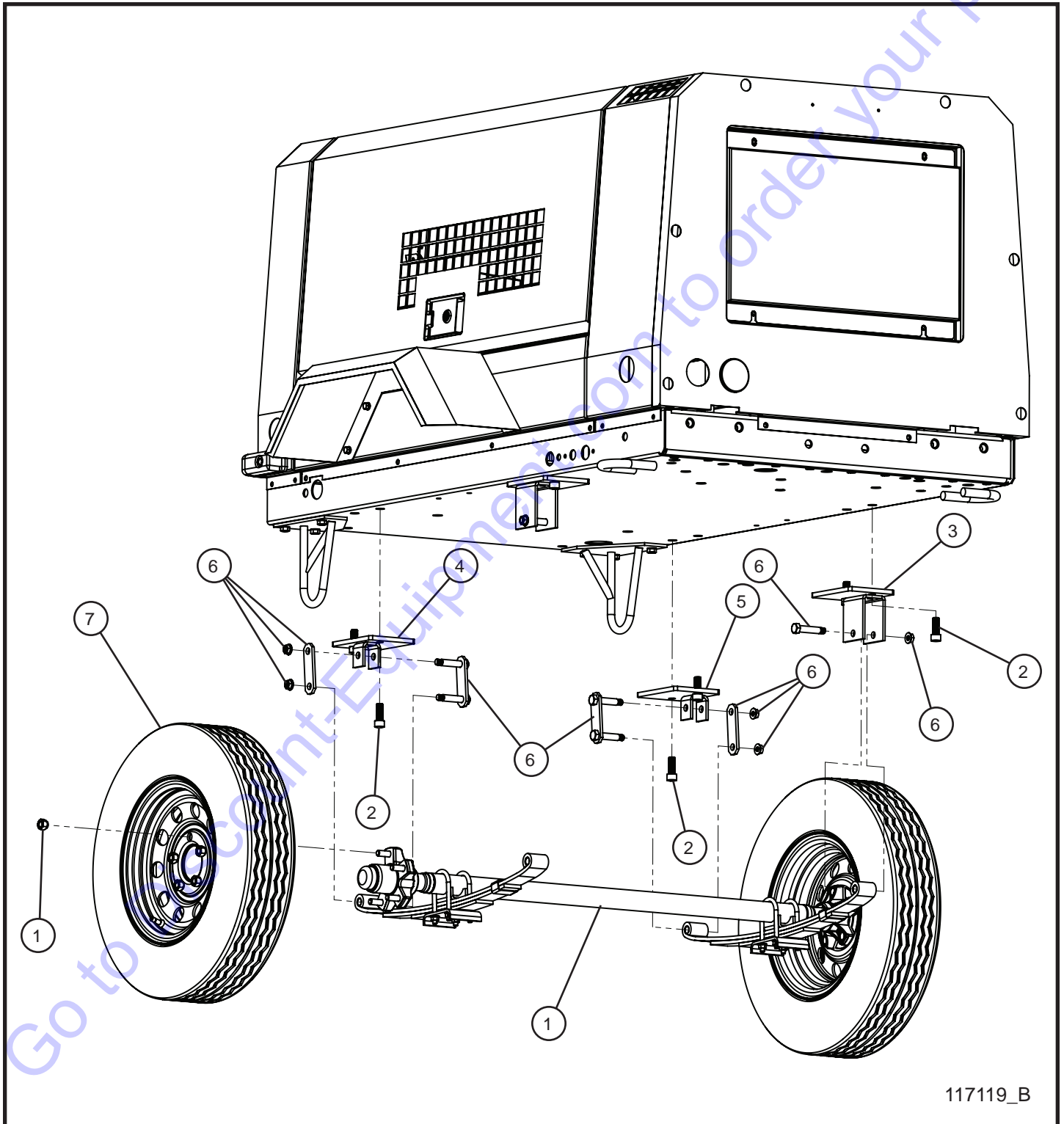

# Maxi-Air 100

SN 28-000001 and UP

## 1.1 - Axle and Wheel Group

Item	Part No.	Part Description	Qty.
1	111570	MAXI-AIR 100 AXLE	1
2	054000	M14 x 2.0 x 35 SOCKET HEAD CAP SCREW	8
3	111571P	MAXI-AIR 100 FRONT SHACKLE WELDMENT	2
4	111573P	MAXI-AIR 100 REAR RIGHT SHACKLE WELDMENT	1
5	111575P	MAXI-AIR 100 REAR LEFT SHACKLE WELDMENT	1
6	117120	SINGLE AXLE SUSPENSION KIT	6
7	112801	13" WHEEL/TIRE ASSEMBLY RADIAL ST1755/80R13	2

NS - Not Shown

\*\*\* - Contact Allmand for more information.

Go to Discount-Equipment.com to protect your parts

## 1.2 - Tongue Group

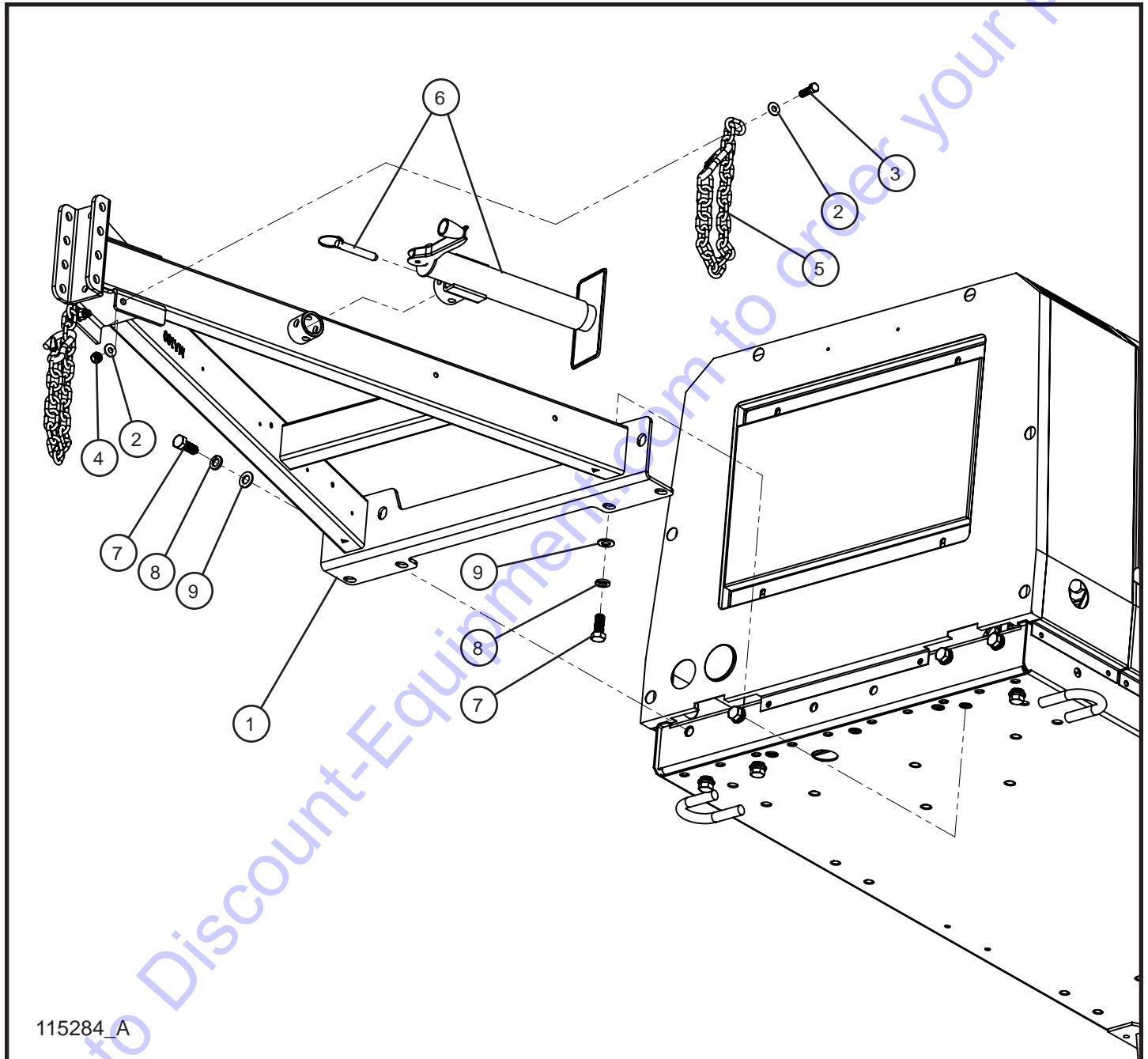

115284\_A

# Maxi-Air 100

SN 28-000001 and UP

## 1.2 - Tongue Group

Item	Part No.	Part Description	Qty.
1	111965P	MAXI-AIR 100 TONGUE WELDMENT	1
2	047015	3/8 FLAT WASHER	4
3	046160	7/16-14 x 1 1/2 HEX HEAD BOLT	2
4	044043	7/16-14 NYLOCK HEX NUT	2
5	049040	CHAIN TOW CLASS III 27 IN.	2
6	108726	TOP CRANK TUBE MOUNT JACK	1
7	***	M16 x 2 x 40mm HEX HEAD BOLT	8
8	***	LOCK WASHER	8
9	***	FLAT WASHER	8

NS - Not Shown

\*\*\* - Contact Allmand for more information.

Go to [Discount-Equipment.com](http://Discount-Equipment.com) to order your parts



## 1.3 - Tongue Coupler Options

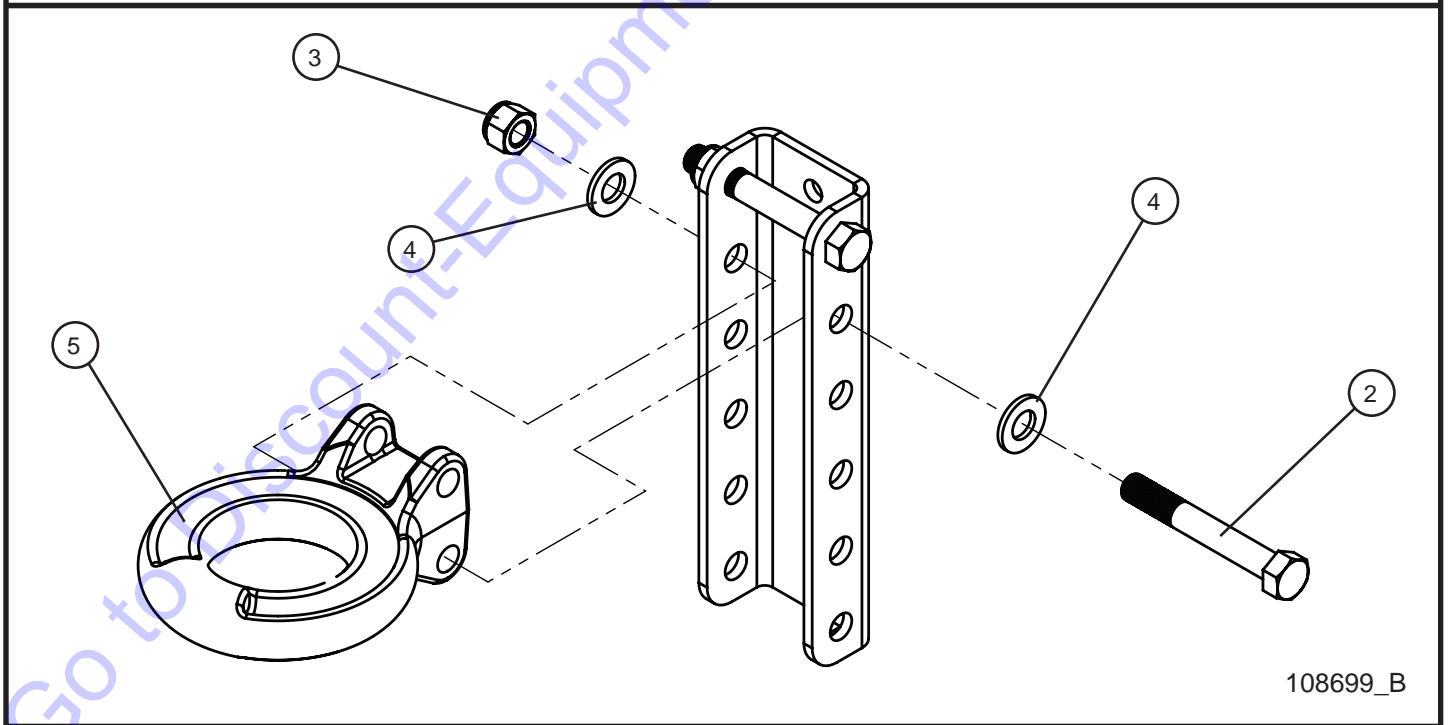
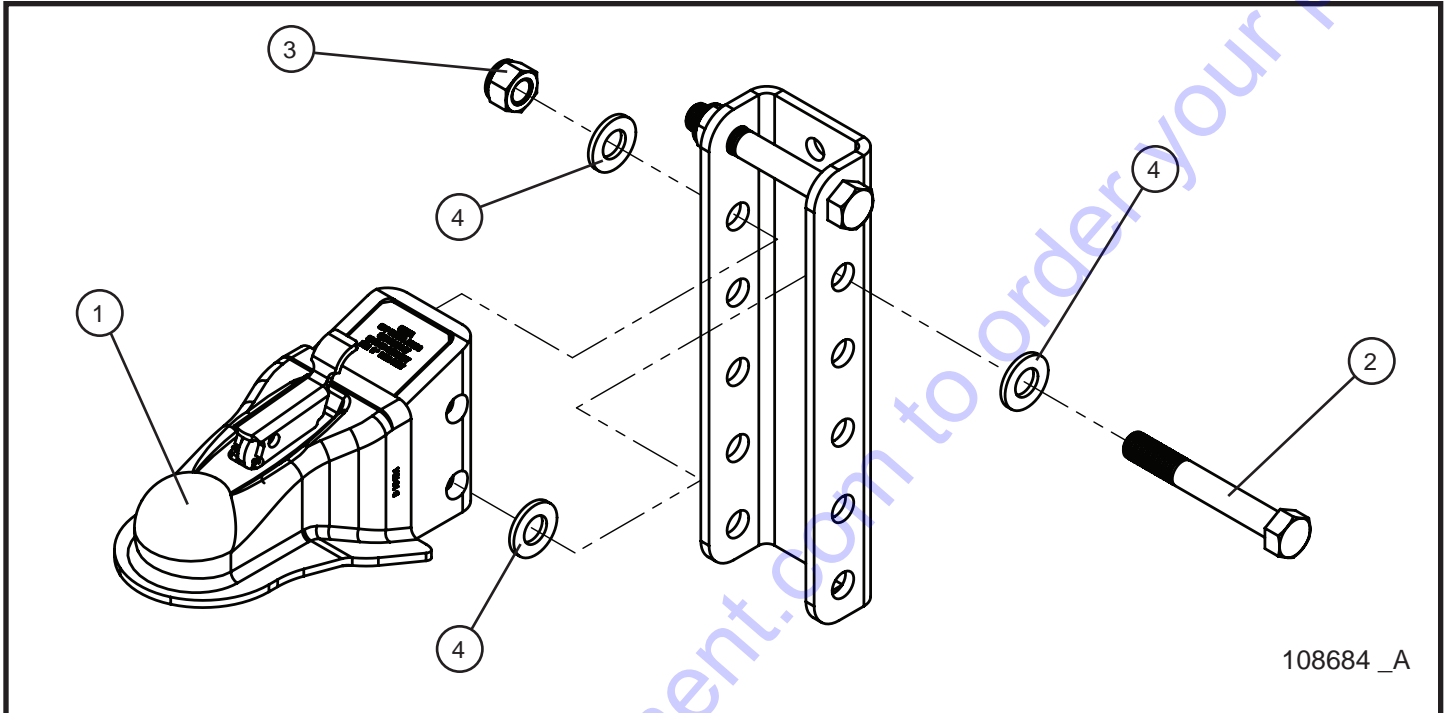

# Maxi-Air 100

SN 28-000001 and UP

## 1.3 - Tongue Coupler Options

Item	Part No.	Part Description	Qty.
1	109976	COUPLER BALL 2.313 ADJUSTABLE STAMPED	1
2	046255	5/8-11 x 5 HEX HEAD CS GR5 PL	2
3	044053	5/8-11 NYLOCK HEX NUT PL	2
4	047031	5/8 FLAT WASHER HDND PL	3
5	106720	RING PINTLE 3.00 ADJUSTABLE	1

NS - Not Shown

\*\*\* - Contact Allmand for more information.

Go to [Discount-Equipment.com](http://Discount-Equipment.com) to order your parts

## 1.4 - Front and Top Enclosure Panels

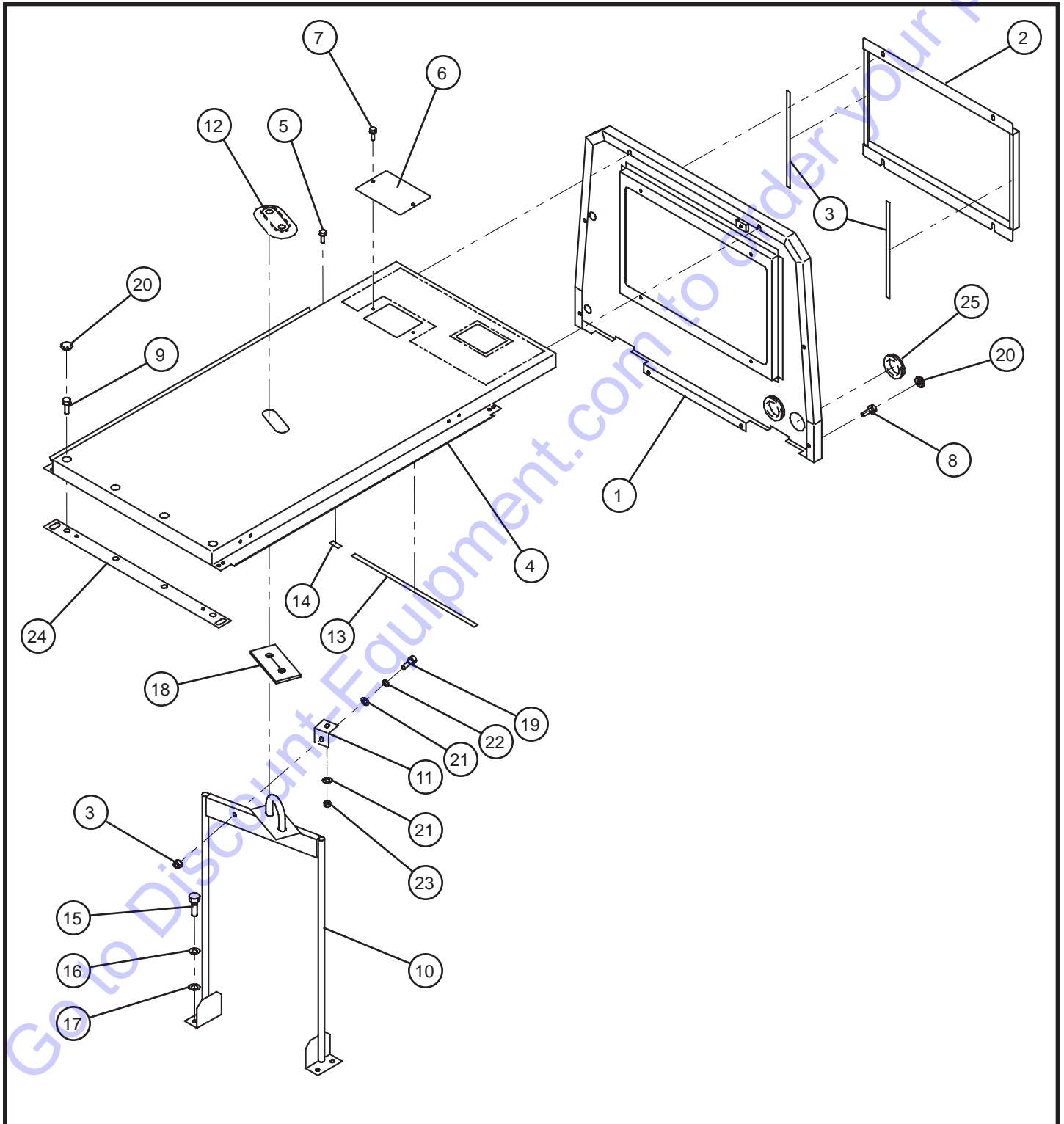

# Maxi-Air 100

SN 28-000001 and UP

## 1.4 - Front and Top Enclosure Panels

Item	Allmand No.	Part Description	Qty.
1	***	COVER	1
2	***	COVER	1
3	***	SEAL RUBBER	2
4	***	TOP COVER	1
5	***	BOLT, W/W	12
6	110472	COVER	1
7	***	BOLT, W/W	2
8	***	BOLT, W/W	40
9	***	FLANGE BOLT	4
10	***	LIFTING BAIL	1
11	***	STAY	1
12	***	CAP	1
13	***	CUSHION RUBBER	1
14	***	CUSHION RUBBER	1
15	***	BOLT	4
16	***	SPRING WASHER	4
17	***	PLAIN WASHER	4
18	***	CUSHION RUBBER	1
19	***	BOLT	1
20	114317	CAP	10
21	***	WASHER	2
22	***	SPRING WASHER	1
23	***	NUT, W/W	1
24	***	CUSHION RUBBER	1
25	110370	GROMMET	2
NS	116934	URETHANE FOAM KIT PANELS	1

NS - Not Shown

\*\*\* - Contact Allmand for more information.

## 1.5 - Left Enclosure Panels and Door

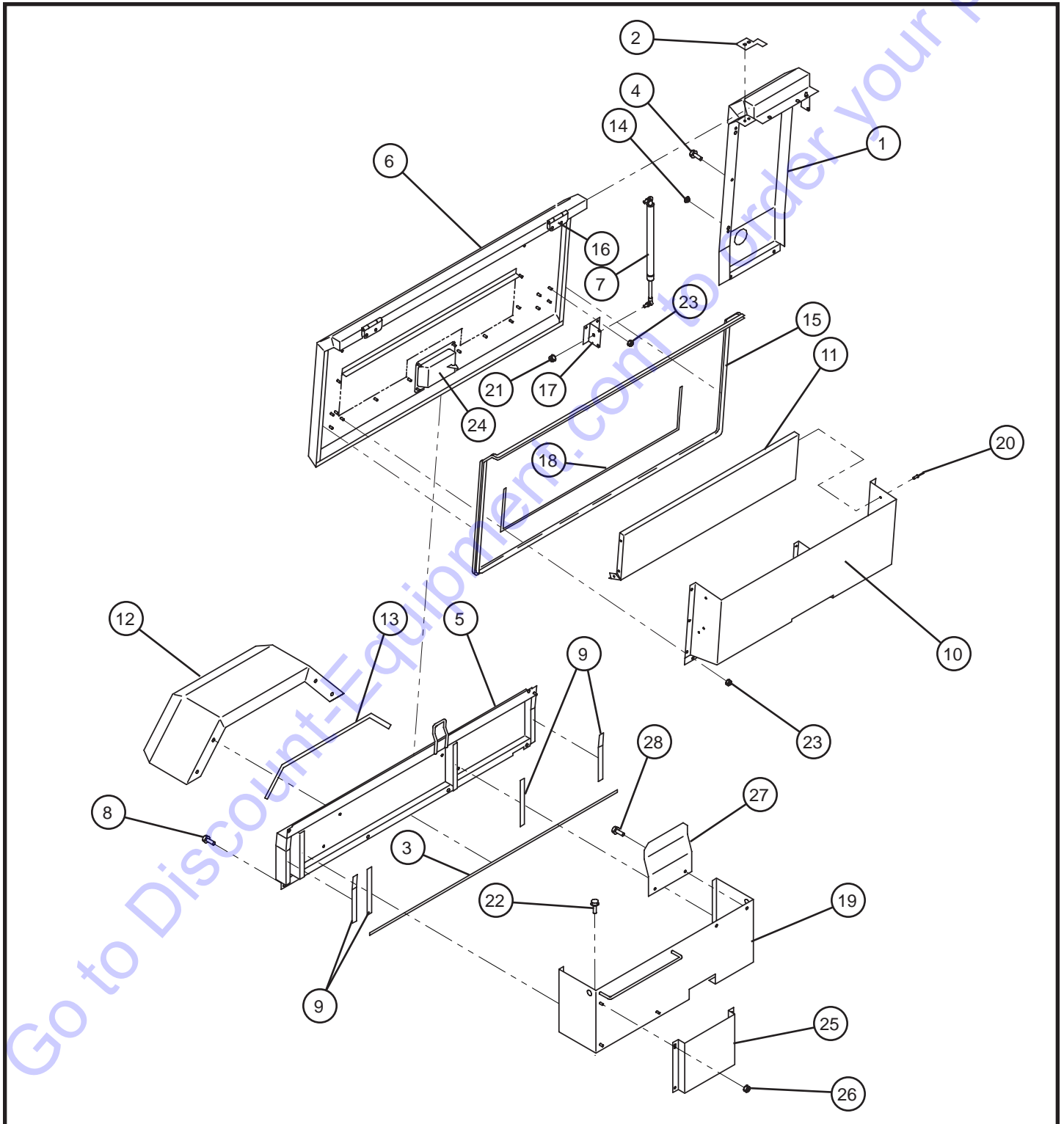

# Maxi-Air 100

SN 28-000001 and UP

## 1.5 - Left Enclosure Panels and Door

Item	Allmand No.	Part Description	Qty.
1	***	COVER	1
2	***	CUSHION RUBBER	1
3	***	SEAL RUBBER	2
4	***	BOLT, W/W	12
5	***	SIDE COVER	1
6	116932	DOOR	1
7	116933	DUMPER	4
8	***	BOLT,W/W	40
9	***	SEAL RUBBER	6
10	***	DUCT	1
11	***	DUCT	1
12	112120	FENDER	2
13	114461	SEAL RUBBER	2
14	114253	GROMMET	6
15	***	SEAL RUBBER	2
16	116887	HINGE	4
17	***	BRACKET	2
18	***	SEAL RUBBER	1
19	***	BRACKET	1
20	114251	BLIND RIVET PIPE	14
21	114249	HEXAGON FLANGE NUT	9
22	110515	FLANGE BOLT	10
23	114248	HEXAGON FLANGE NUT	50
24	110499	LATCH ASS'Y	2
	112827	KEY	2
25	***	TOOL BOX	1
26	114248	HEXAGON FLANGE NUT	4
27	***	COVER	1
28	***	FLANGE BOLT	2
NS	116935	URETHANE FOAM KIT DOORS	1
NS	116934	URETHANE FOAM KIT PANELS	1

NS - Not Shown

\*\*\* - Contact Allmand for more information.

## 1.6 - Right Enclosure Panels and Door

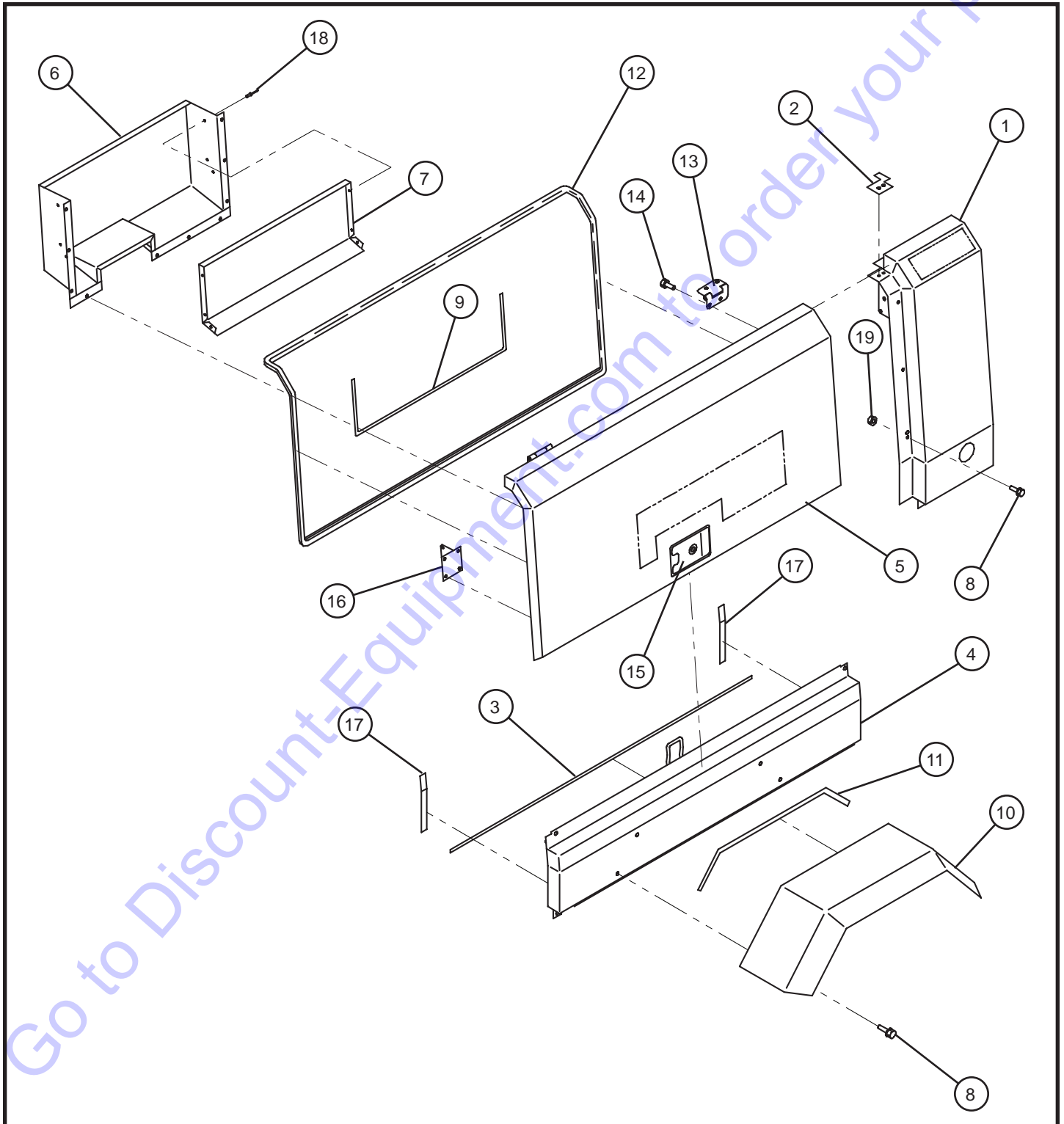

# Maxi-Air 100

SN 28-000001 and UP

## 1.6 - Right Enclosure Panels and Door

Item	Allmand No.	Part Description	Qty.
1	***	COVER	1
2	***	CUSHION RUBBER	1
3	***	SEAL RUBBER	2
4	***	SIDE COVER	1
5	116931	DOOR	1
6	***	DUCT	1
7	***	DUCT	1
8	***	BOLT, W/W	40
9	***	SEAL RUBBER	1
10	112120	FENDER	2
11	114461	SEAL RUBBER	2
12	***	SEAL RUBBER	2
13	116887	HINGE	4
14	114242	BOLT	16
15	110499	LATCH ASS'Y	2
	112827	KEY	2
16	***	BRACKET	1
17	***	SEAL RUBBER	6
18	114251	BLIND RIVET PIPE	14
19	114248	HEXAGON FLANGE NUT	50
NS	116933	DUMPER	4
NS	116935	URETHANE FOAM KIT DOORS	1
NS	116934	URETHANE FOAM KIT PANELS	1

NS - Not Shown      \*\*\* - Contact Allmand for more information.

Go to [DiscoverAllmand.com](http://DiscoverAllmand.com) to order your parts



## 1.7 - Rear Enclosure Panels

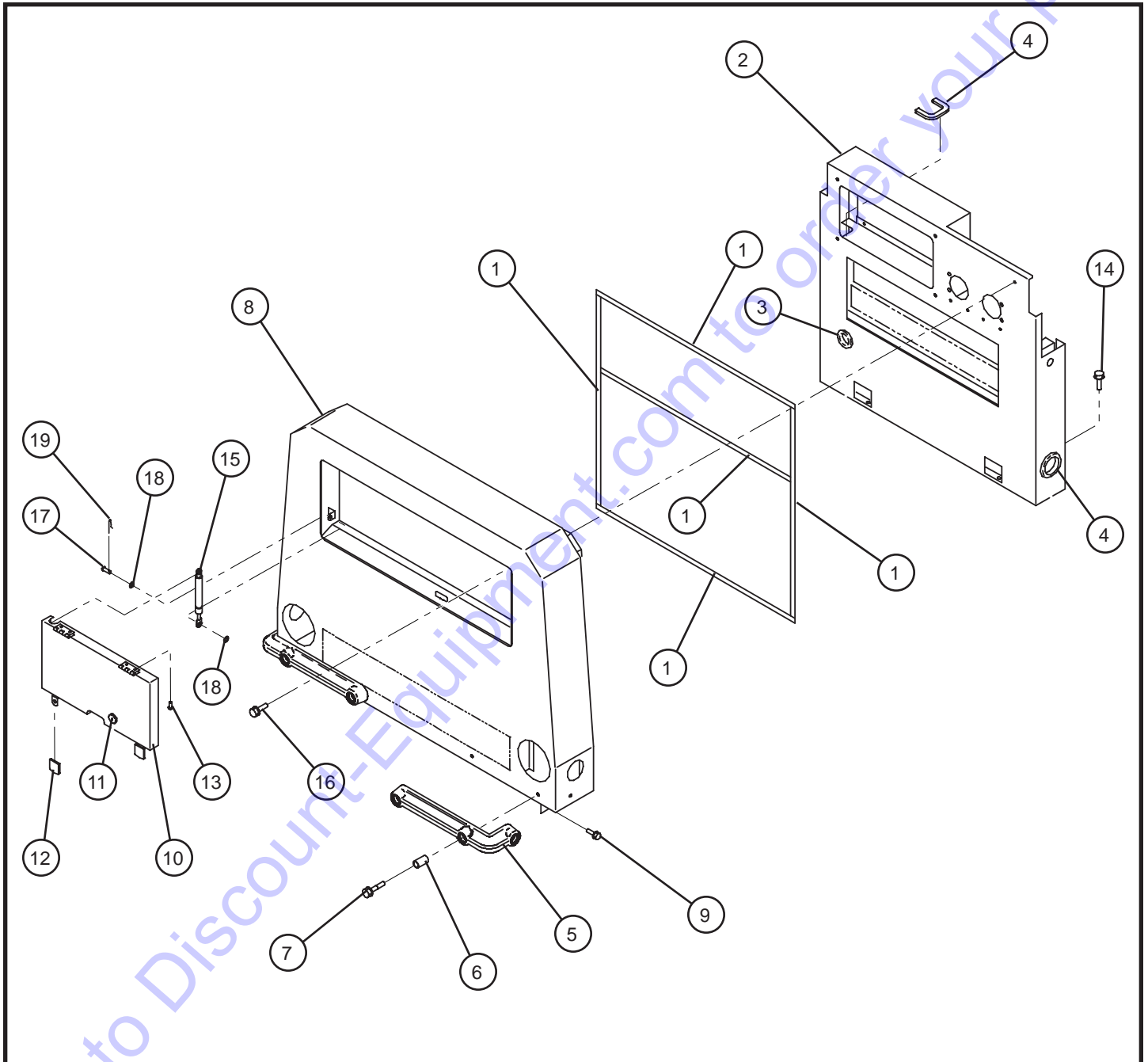

# Maxi-Air 100

SN 28-000001 and UP

## 1.7 - Rear Enclosure Panels

Item	Allmand No.	Part Description	Qty.
1	***	SEAL RUBBER	5
2	***	COVER	1
3	***	GROMMET	1
4	110845	EYELET RING	2
5	***	CUSHION RUBBER	2
6	***	COLLAR	6
7	114245	BOLT, W/W	6
8	***	COVER	1
9	***	BOLT, W/W	40
10	***	DOOR	1
11	116888	LOCK	1
12	***	CAP	2
13	***	SCREW	4
14	110515	FLANGE BOLT	10
15	114383	DUMPER	1
16	***	BOLT, W/W	1
17	114343	PIN	2
18	***	PLAIN WASHER	4
19	***	PIN	2
NS	114253	GROMMET	6
NS	116934	URETHANE FOAM KIT PANELS	1

NS - Not Shown

\*\*\* - Contact Allmand for more information.

## 2.1 - Maxi-Air 100 Engine and Mounting

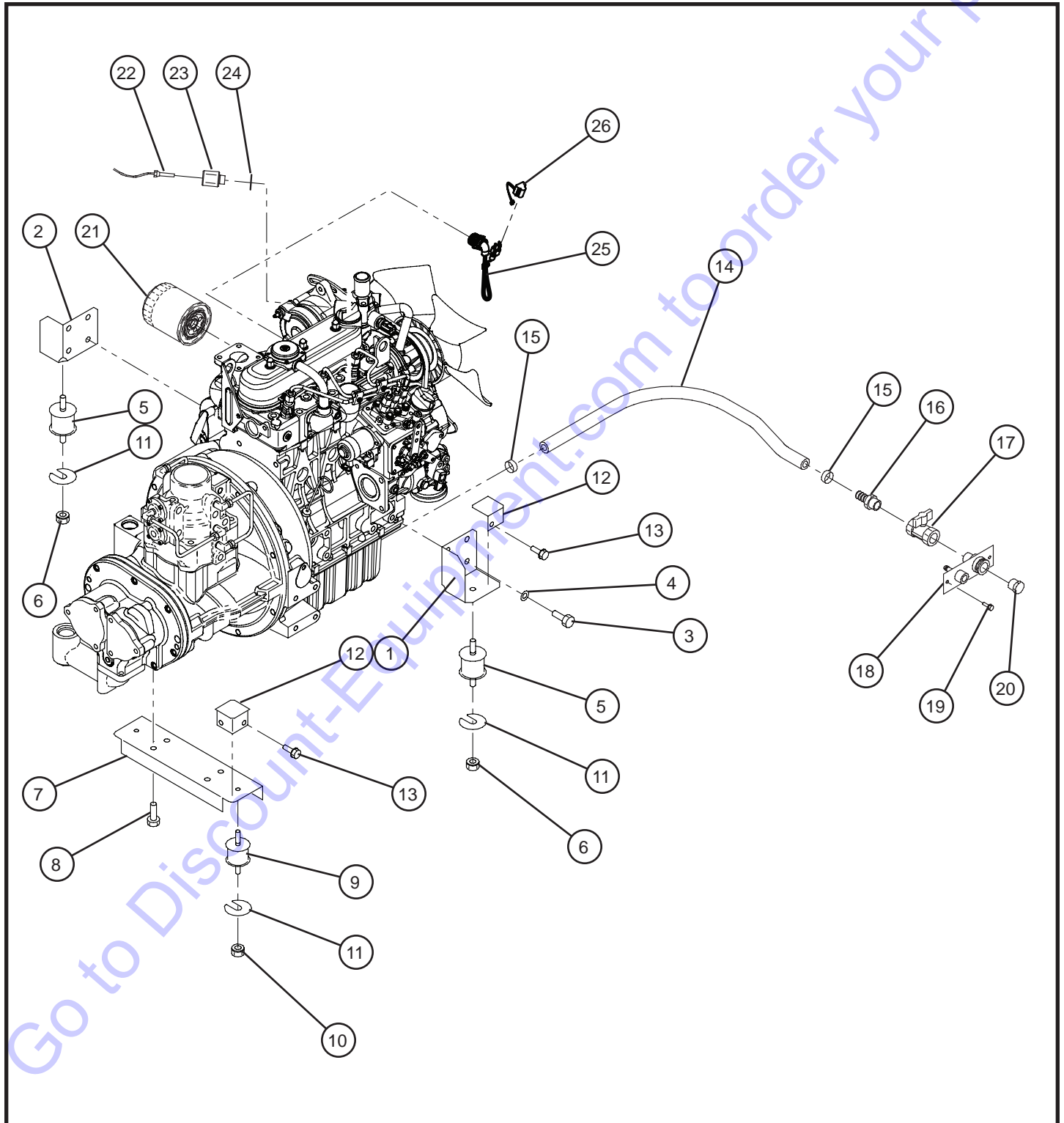

# Maxi-Air 100

SN 28-000001 and UP

## 2.1 - Maxi-Air 100 Engine and Mounting

Item	Allmand No.	Part Description	Qty.
1	***	BRACKET	1
2	***	BRACKET	1
3	***	BOLT	8
4	***	SPRING WASHER	8
5	***	VIBRATION ISOLATOR ASS'Y	2
6	***	NUT, W/W	4
7	***	BRACKET	1
8	***	FLANGE BOLT	4
9	114443	VIBRATION ISOLATOR ASS'Y	2
10	***	NUT, W/W	4
11	***	SHIM	1
12	***	BRACKET	4
13	110515	FLANGE BOLT	8
14	***	HOSE	1
15	***	HOSE CLIP	2
16	***	JOINT	1
17	110856	VALVE	1
18	***	JOINT	1
19	***	BOLT, W/W	2
20	***	PLUG	1
21	116919	FILTER ASS'Y	1
22	116874	THERMO SENSOR	1
23	***	NIPPLE	1
24	***	GASKET	1
25	352373	1" NPT / 400W / 120V BLOCK HEATER	1
26	105995	120V CORD END COVER	1
NS	***	50A FUSE BOX	1
NS	***	WIRING HARNESS	1
NS	116928	PRESSURE SWITCH	1
NS	116929	TACHO SENSOR	1

NS - Not Shown

\*\*\* - Contact Allmand for more information.

## 2.2 - Engine Finger and Fan Guards

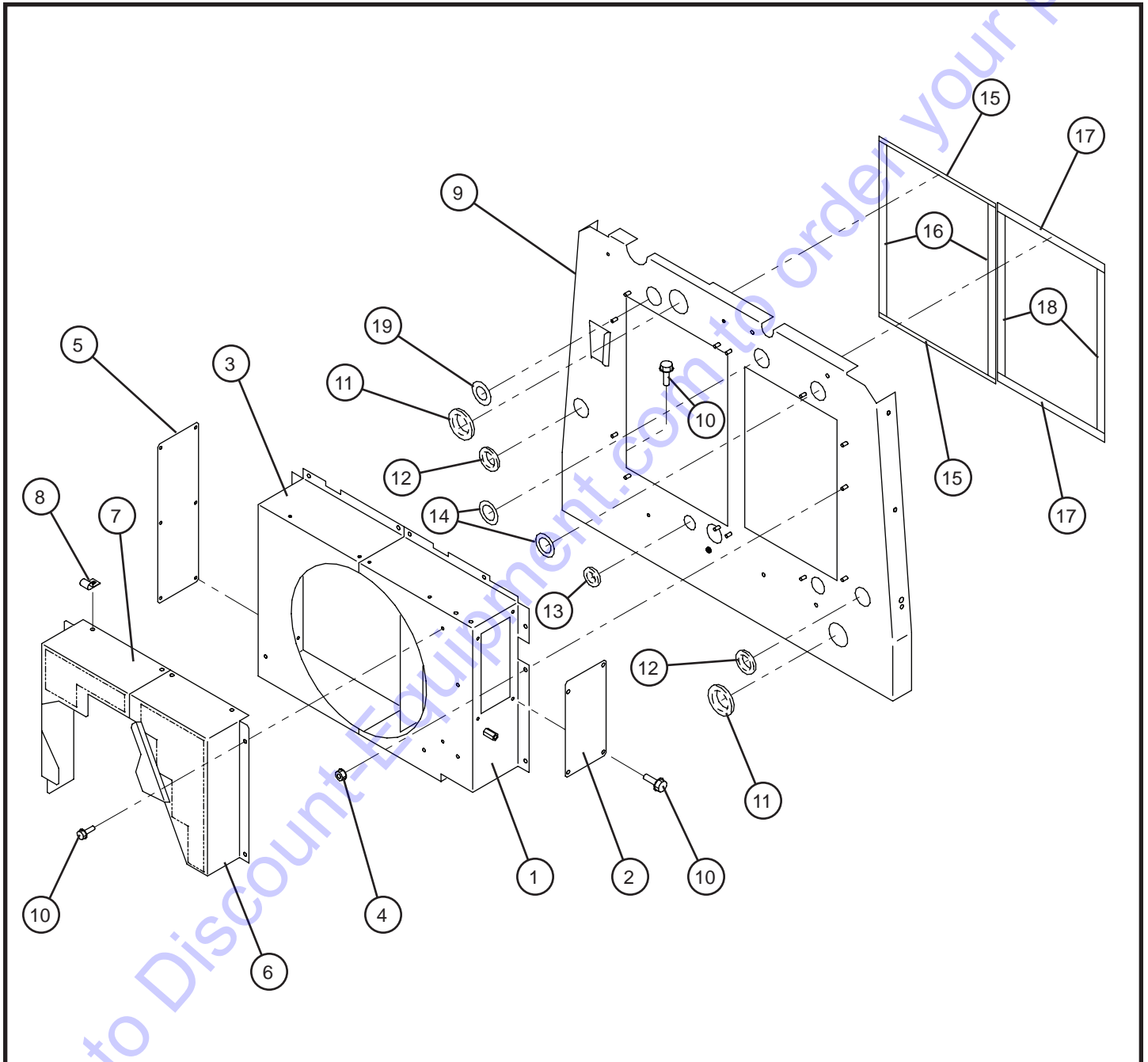

# Maxi-Air 100

SN 28-000001 and UP

## 2.2 - Engine Finger and Fan Guards

Item	Allmand No.	Part Description	Qty.
1	116902	SHROUD, FAN	1
2	***	PLATE	1
3	116903	SHROUD, FAN	1
4	114248	HEXAGON FLANGE NUT	13
5	***	PLATE	1
6	116904	GUARD, FAN	1
7	116905	GUARD, FAN	1
8	***	CLIP	1
9	***	COVER	1
	***	COVER	1
10	110514	FLANGE BOLT	25
11	***	GROMMET	2
12	***	GROMMET	2
13	***	GROMMET	1
14	***	CUSHION RUBBER	2
15	***	SEAL RUBBER	2
16	***	SEAL RUBBER	2
17	***	SEAL RUBBER	2
18	114447	SEAL RUBBER	2
19	***	CUSHION RUBBER	1
NS	110370	GROMMET	1

NS - Not Shown

\*\*\* - Contact Allmand for more information.

## 2.3 - Engine Cooling Group

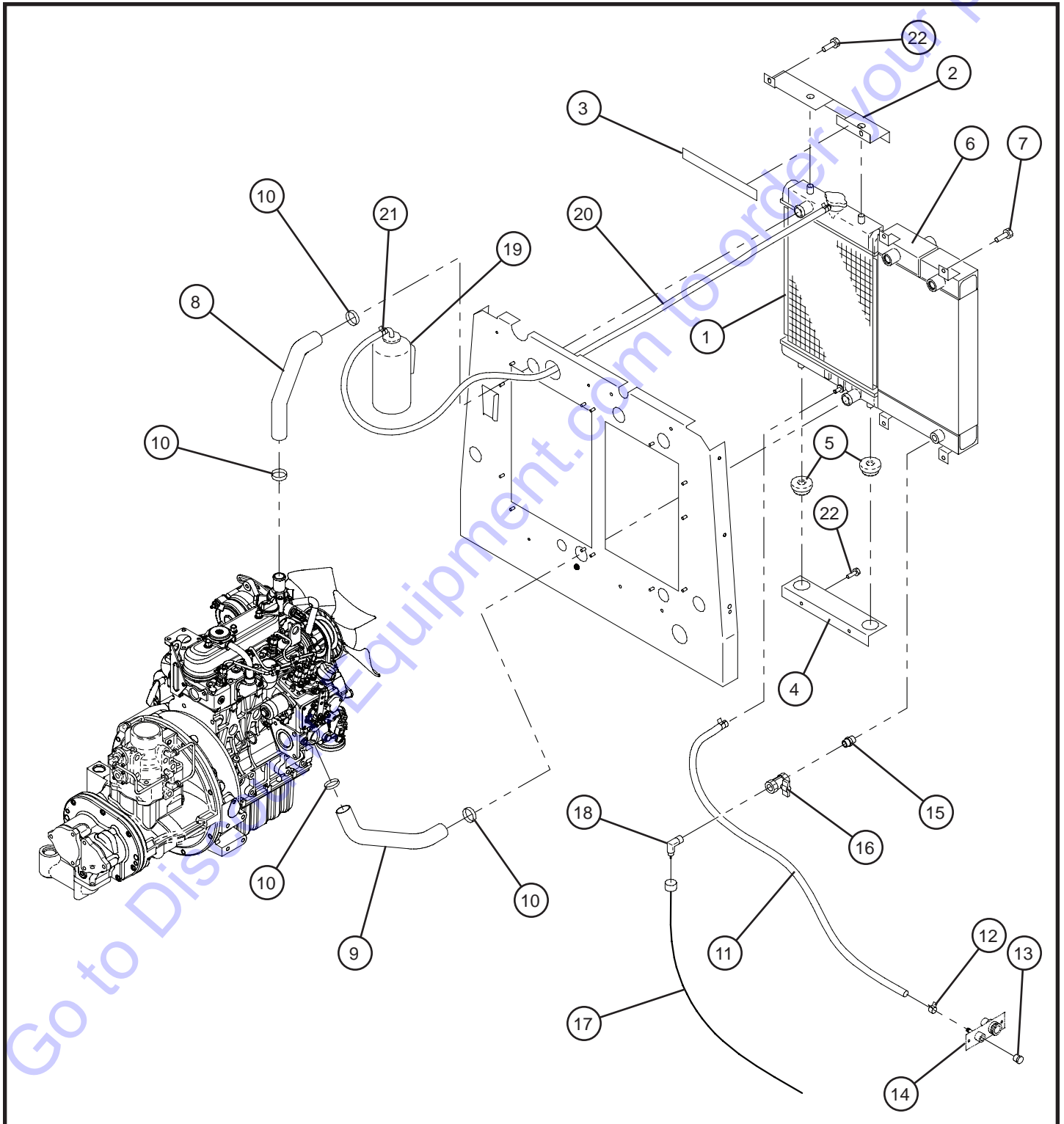

# Maxi-Air 100

SN 28-000001 and UP

## 2.3 - Engine Cooling Group

Item	Allmand No.	Part Description	Qty.
1	116898	RADIATOR	1
	110565	CAP	1
2	***	BRACKET	1
3	***	SEAL RUBBER	1
4	***	BRACKET	1
5	112855	RUBBER	2
6	116899	OIL COOLER	1
7	110515	FLANGE BOLT	4
8	116900	HOSE	1
9	116901	HOSE	1
10	***	HOSE CLIP	4
11	116906	HOSE	1
12	***	HOSE CLIP	2
13	***	PLUG	1
14	***	JOINT	1
15	***	NIPPLE	1
16	***	VALVE	1
17	***	NYLON TUBE, W/N	1
18	110824	NIPPLE ELBOW	1
19	112807	RESERVE TANK ASS'Y	1
20	116907	HOSE	1
21	110520	HOSE CLIP	2
22	110514	FLANGE BOLT	25

NS - Not Shown

\*\*\* - Contact Allmand for more information.

Go to [DiscoverAllmand.com](http://DiscoverAllmand.com) to order your parts



## 2.4 - Engine Air Intake Group

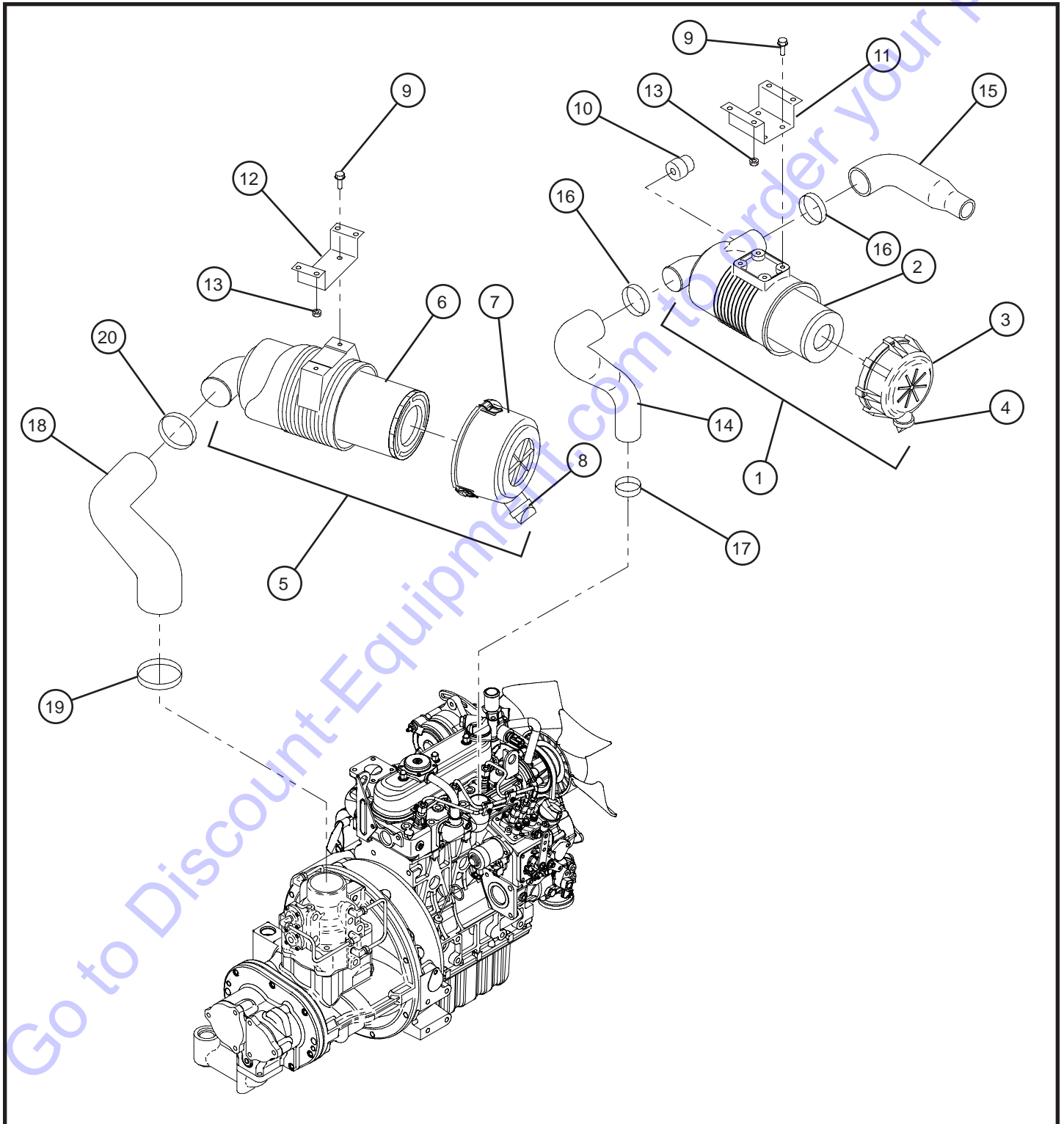

# Maxi-Air 100

SN 28-000001 and UP

## 2.4 - Engine Air Intake Group

Item	Allmand No.	Part Description	Qty.
1	116889	AIR FILTER ASS'Y	1
2	116890	ELEMENT	1
3	112824	CUP	1
4	113049	VACUATOR VALVE	1
5	110633	AIR FILTER ASS'Y	1
6	110634	ELEMENT	1
7	113048	CUP	1
8	113049	VACUATOR VALVE	1
9	***	FLANGE BOLT	6
10	110637	FILTER SERVICE INDICATOR	2
11	***	BRACKET	1
12	***	BRACKET	1
13	114249	HEXAGON FLANGE NUT	8
14	116891	HOSE	1
15	116892	HOSE	1
16	***	HOSE CLIP	2
17	***	HOSE CLIP	1
18	116893	HOSE	1
19	***	HOSE CLIP	1
20	112991	HOSE CLIP	1

NS - Not Shown

\*\*\* - Contact Allmand for more information.

Go to Discount-Equipment.com to order your parts

## 2.5 - Engine Exhaust Group

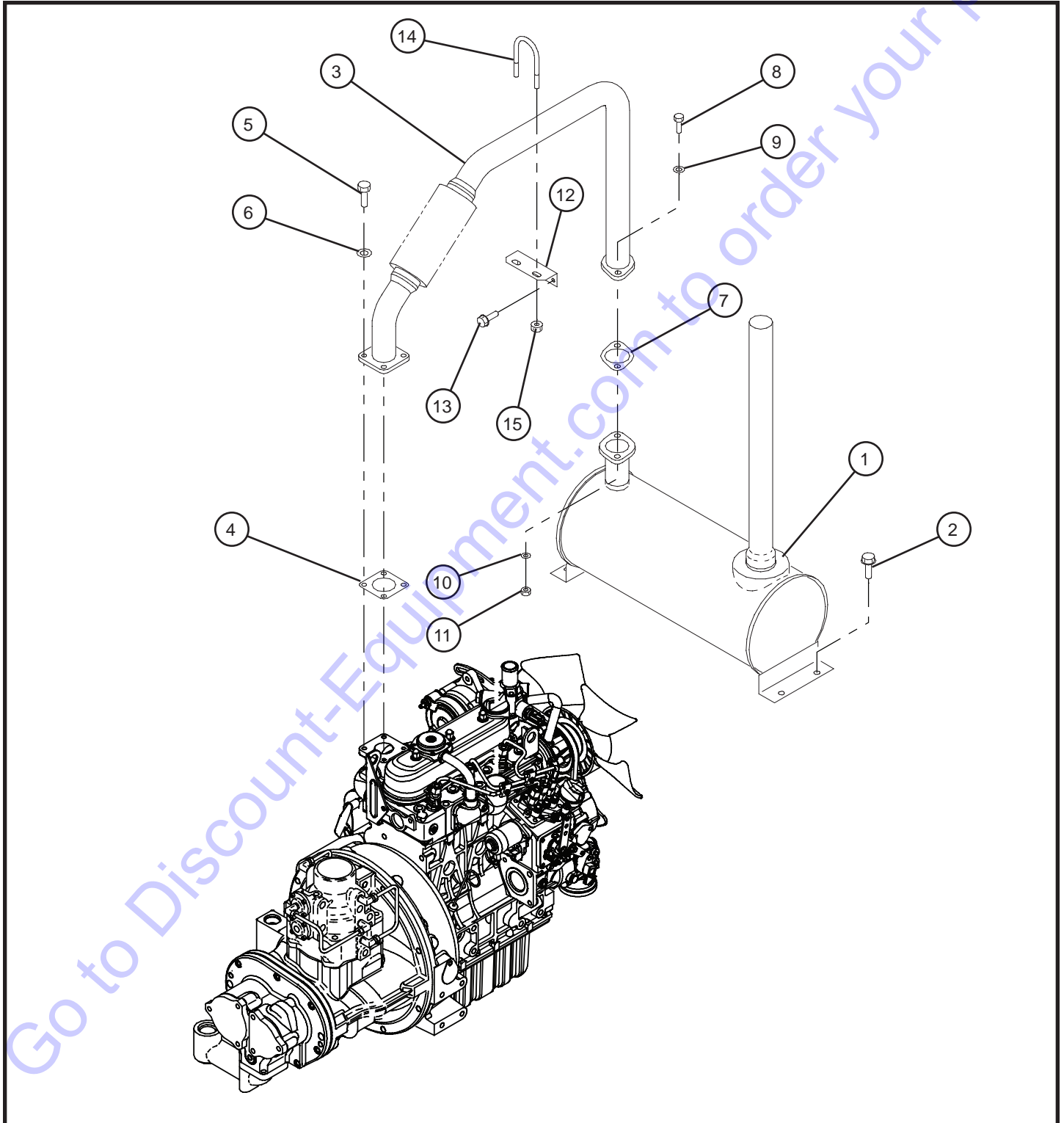

# Maxi-Air 100

SN 28-000001 and UP

## 2.5 - Engine Exhaust Group

Item	Allmand No.	Part Description	Qty.
1	116920	EXHAUST MUFFLER	1
2	***	BOLT, W/W	4
3	116921	PIPE,EXHAUST	1
4	***	GASKET	1
5	***	BOLT	4
6	***	SPRING WASHER	4
7	***	GASKET	1
8	***	BOLT	2
9	***	PLAIN WASHER	2
10	***	SPRING WASHER	2
11	***	NUT	2
12	***	BRACKET	1
13	110514	FLANGE BOLT	2
14	***	U-BOLT	1
15	114249	HEXAGON FLANGE NUT	2

NS - Not Shown

\*\*\* - Contact Allmand for more information.

Go to Discount-Equipment.com to order your parts

## 2.6 - Fuel Tank and Fuel Lines

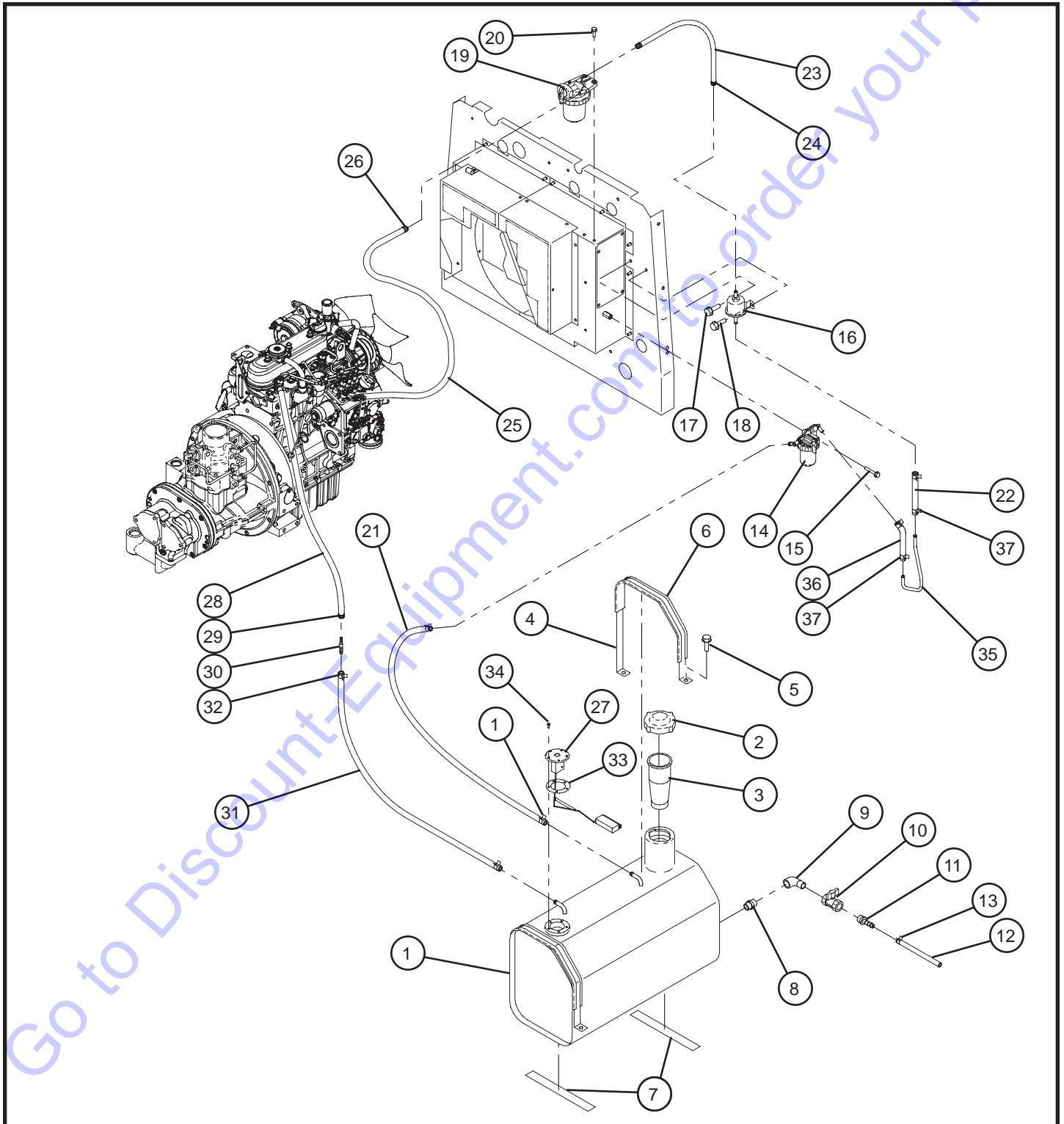

# Maxi-Air 100

SN 28-000001 and UP

## 2.6 - Fuel Tank and Fuel Lines

Item	Allmand No.	Part Description	Qty.
1	***	FUEL TANK	1
	***	FUEL TANK	1
2	110495	CAP	1
3	110496	STRAINER	1
4	***	BELT	2
5	110515	FLANGE BOLT	4
6	***	CUSHION	2
7	***	CUSHION RUBBER	2
8	***	NIPPLE	1
	***	PIPE	1
9	110854	ELBOW	1
10	110856	VALVE	1
11	***	NIPPLE	1
12	***	HOSE	1
13	110520	HOSE CLIP	1
14	116922	SEDIMENTER	1
	116923	ELEMENT	1
15	***	FLANGE BOLT	1
16	***	FUEL PUMP	1
17	110514	FLANGE BOLT	2
18	110515	FLANGE BOLT	1
19	116924	FUEL FILTER	1
	116925	ELEMENT	1
20	112968	FLANGE BOLT	2
21	***	HOSE	1
22	***	HOSE	1
	***	HOSE	1
23	***	HOSE	1
24	114397	HOSE CLIP	2
25	***	PIPE	1
26	***	CLIP	2
27	110688	SENDING UNIT	1
28	***	HOSE	1
29	***	HOSE CLIP	2
30	***	NIPPLE	1
31	***	HOSE	1
32	110520	HOSE CLIP	4
33	***	GASKET	1
34	***	SCREW,W/W	5
35	***	PIPE	1
36	***	HOSE	1
37	110520	HOSE CLIP	2
	***	HOSE CLIP	2

NS - Not Shown

\*\*\* - Contact Allmand for more information.

## 3.1 - Air End (1 of 2)

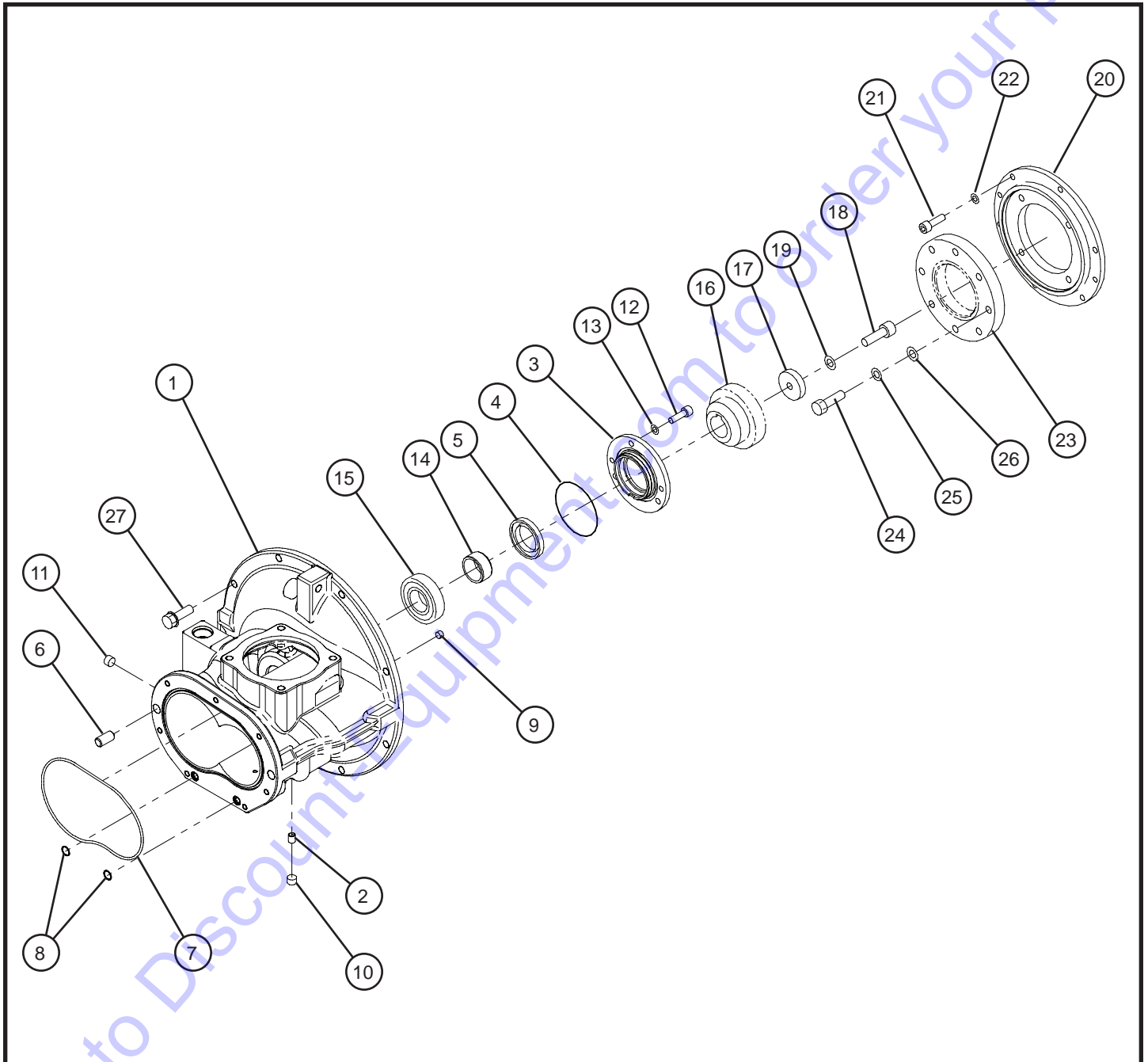

# Maxi-Air 100

SN 28-000001 and UP

## 3.1 - Air End (1 of 2)

Item	Allmand No.	Part Description	Qty.
1	***	CYLINDER,1ST	1
2	***	ORIFICE	1
3	***	COVER, OIL SEAL	1
4	110861	O-RING	1
5	***	OIL SEAL	1
6	***	PIN	2
7	***	O-RING	1
8	***	O-RING	2
9	***	PLUG	3
10	***	PLUG	2
11	***	PLUG	1
12	***	SOCKET BOLT	3
13	***	SPRING WASHER	9
14	***	COLLAR	1
15	***	BEARING, ROTOR	1
	***	BEARING, ROTOR	1
16	***	GEAR, DRIVEN	1
17	***	PLATE	1
18	***	SOCKET BOLT	1
19	***	LOCK WASHER	1
20	***	SPACER	1
21	***	SOCKET BOLT	6
22	***	SPRING WASHER	6
23	***	GEAR, DRIVE	1
24	***	BOLT	4
25	***	SPRING WASHER	4
26	***	WASHER	4
27	***	BOLT, W/W	8

NS - Not Shown

\*\*\* - Contact Allmand for more information.



## 3.1 - Air End (2 of 2)

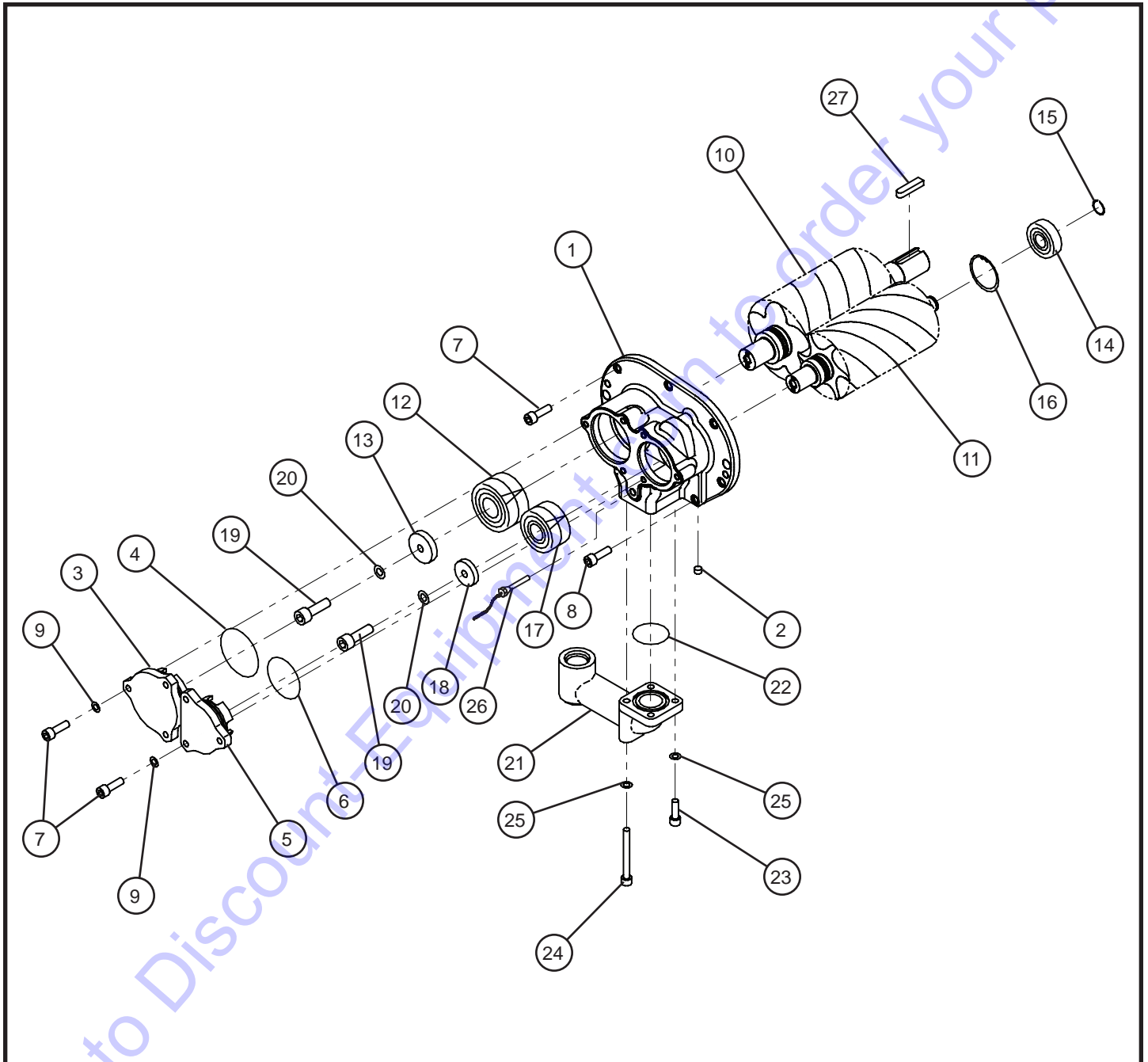

# Maxi-Air 100

SN 28-000001 and UP

## 3.1 - Air End (2 of 2)

Item	Allmand No.	Part Description	Qty.
1	***	CASING, DISCHARGE	1
2	***	PLUG	3
3	114347	END COVER	1
4	111728	O-RING	1
5	114348	END COVER	1
6	113025	O-RING	1
7	***	SOCKET BOLT	11
8	***	SOCKET BOLT	2
9	***	SPRING WASHER	9
10	***	ROTOR, MALE	1
11	***	ROTOR, FEMALE	1
12	***	BEARING, COMPLETE	1
13	***	PLATE	1
14	***	BEARING, ROTOR	1
15	***	SNAP RING	1
16	***	SNAP RING	1
17	***	BEARING, COMPLETE	1
18	***	PLATE	1
19	***	SOCKET BOLT	2
20	***	LOCK WASHER	2
21	***	DISCHARGE ELBOW	1
22	110575	O-RING	1
23	***	SOCKET BOLT	2
24	***	SOCKET BOLT	2
25	***	SPRING WASHER	4
26	116874	THERMO SENSOR	1
27	***	KEY	1

NS - Not Shown

\*\*\* - Contact Allmand for more information.

## 3.2 - Unloader

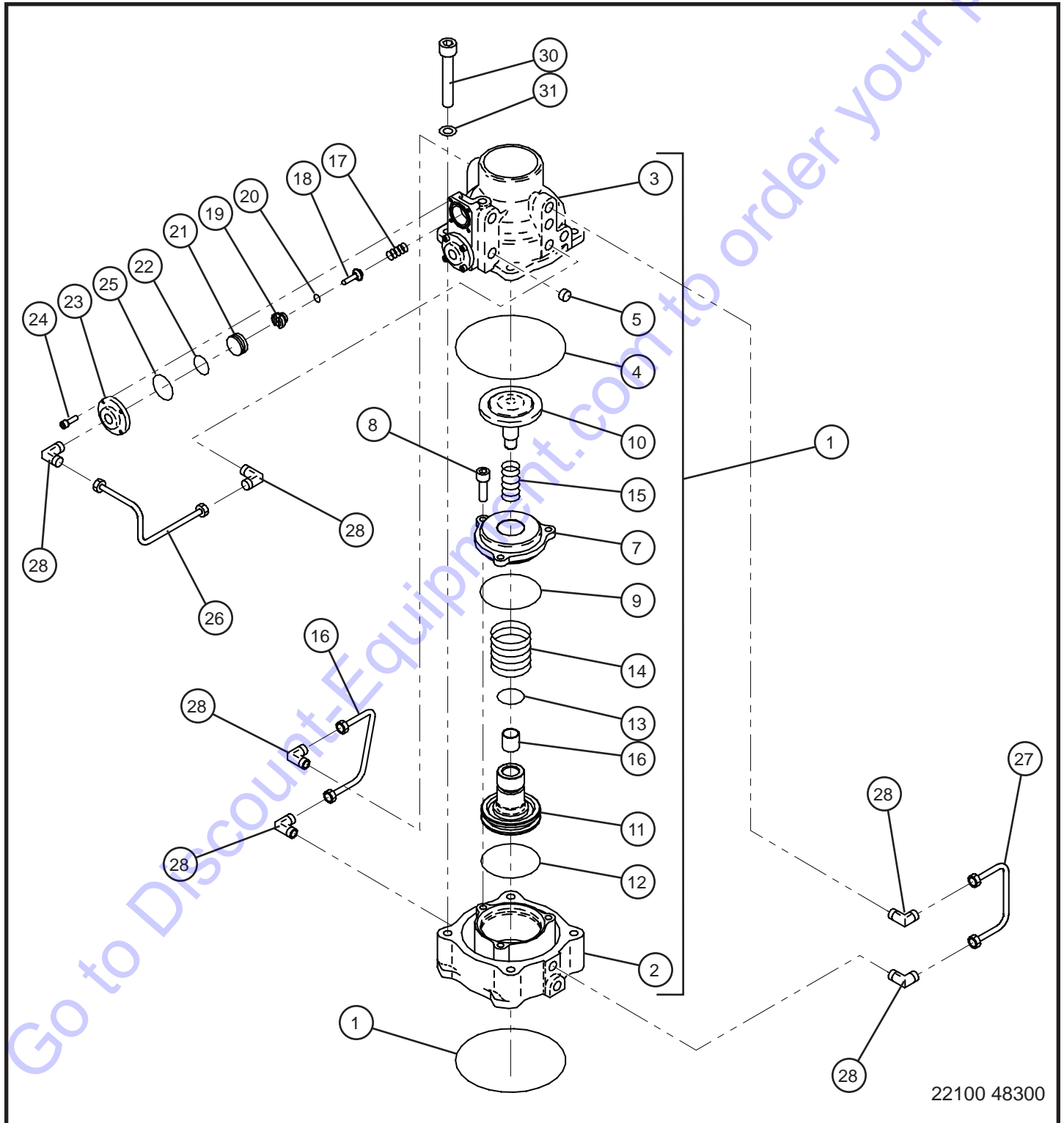

22100 48300

# Maxi-Air 100

SN 28-000001 and UP

## 3.2 - Unloader

Item	Allmand No.	Part Description	Qty.
1	***	UNLOADER ASS'Y	1
2	***	BODY, UNLOADER	1
3	***	COVER, UNLOADER	1
4	111345	O-RING	1
5	***	PLUG	2
6	***	PIPE	1
7	***	COVER, UNLOADER	1
8	***	SOCKET BOLT	3
9	110919	O-RING	1
10	***	VALVE	1
11	***	PISTON,UNLOADER	1
12	111729	O-RING	1
13	111730	O-RING	1
14	***	SPRING	1
15	***	SPRING	1
16	***	BUSHING	1
17	***	SPRING	2
18	111731	NEEDLE VALVE	2
19	111732	VALVE SEAT	2
20	111670	O-RING	2
21	***	PISTON, AUTO-RELIEF	2
22	111671	O-RING	2
23	***	COVER, AUTO-RELIEF	2
24	***	SOCKET BOLT, W/W	8
25	111733	O-RING	2
26	***	PIPE	1
27	***	PIPE	1
28	***	NIPPLE ELBOW	6
29	111345	O-RING	1
30	***	SOCKET BOLT	4
31	***	LOCK WASHER	4

NS - Not Shown

\*\*\* - Contact Allmand for more information.

## 3.3 - Receiver, Separator, and Service Header

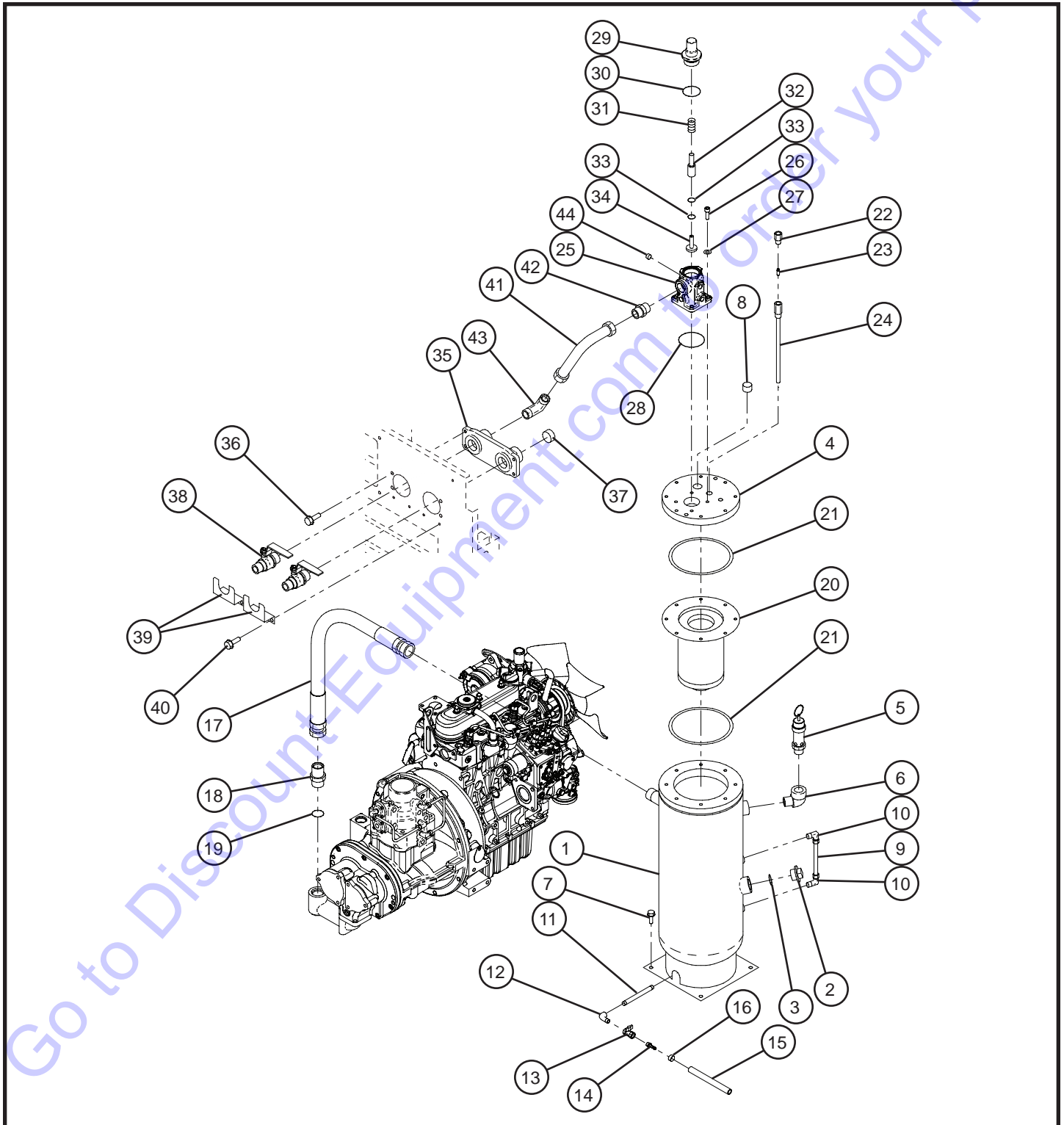

# Maxi-Air 100

SN 28-000001 and UP

## 3.3 - Receiver, Separator, and Service Header

Item	Allmand No.	Part Description	Qty.
1	116894	OIL SEPARATOR	1
	116895	OIL SEPARATOR	1
	116896	OIL SEPARATOR	1
2	***	PLUG(HEA02019)	1
3	110604	O-RING	1
4	***	COVER	1
5	***	SAFETY VALVE ASS'Y	1
	110605	SAFETY VALVE ASS'Y	1
	***	SAFETY VALVE ASS'Y	1
6	110606	ELBOW	1
7	110515	FLANGE BOLT	4
8	***	PLUG	1
9	***	NYLON TUBE,W/N	1
10	110824	NIPPLE ELBOW	2
11	***	PIPE	1
12	110854	ELBOW	1
13	110856	VALVE	1
14	***	NIPPLE	1
15	***	HOSE	1
16	***	HOSE CLIP	1
17	***	HOSE	1
18	***	NIPPLE	1
19	111672	O-RING	1
20	116897	SEPARATOR	1
21	***	GASKET	2
22	***	NIPPLE	1
23	110581	STRAINER	1
24	110580	BUSHING	1
25	***	BODY	1
26	***	SOCKET BOLT	4
27	***	LOCK WASHER	4
28	***	O-RING	1
29	***	BODY	1
30	***	O-RING	1
31	***	SPRING	1
32	***	PISTON	1
33	***	O-RING	2
34	***	PISTON	1
35	***	AIR MANIFOLD	1
36	114244	BOLT, W/W	4
37	***	PLUG	1
38	110632	AIR VALVE	2
39	***	BRACKET	2
40	***	BOLT, W/W	4
41	***	PIPE	1
42	***	NIPPLE	1
43	***	NIPPLE ELBOW	1
44	***	PLUG	1

NS - Not Shown

\*\*\* - Contact Allmand for more information

©2019 Allmand®

## 3.4 - Air Lines

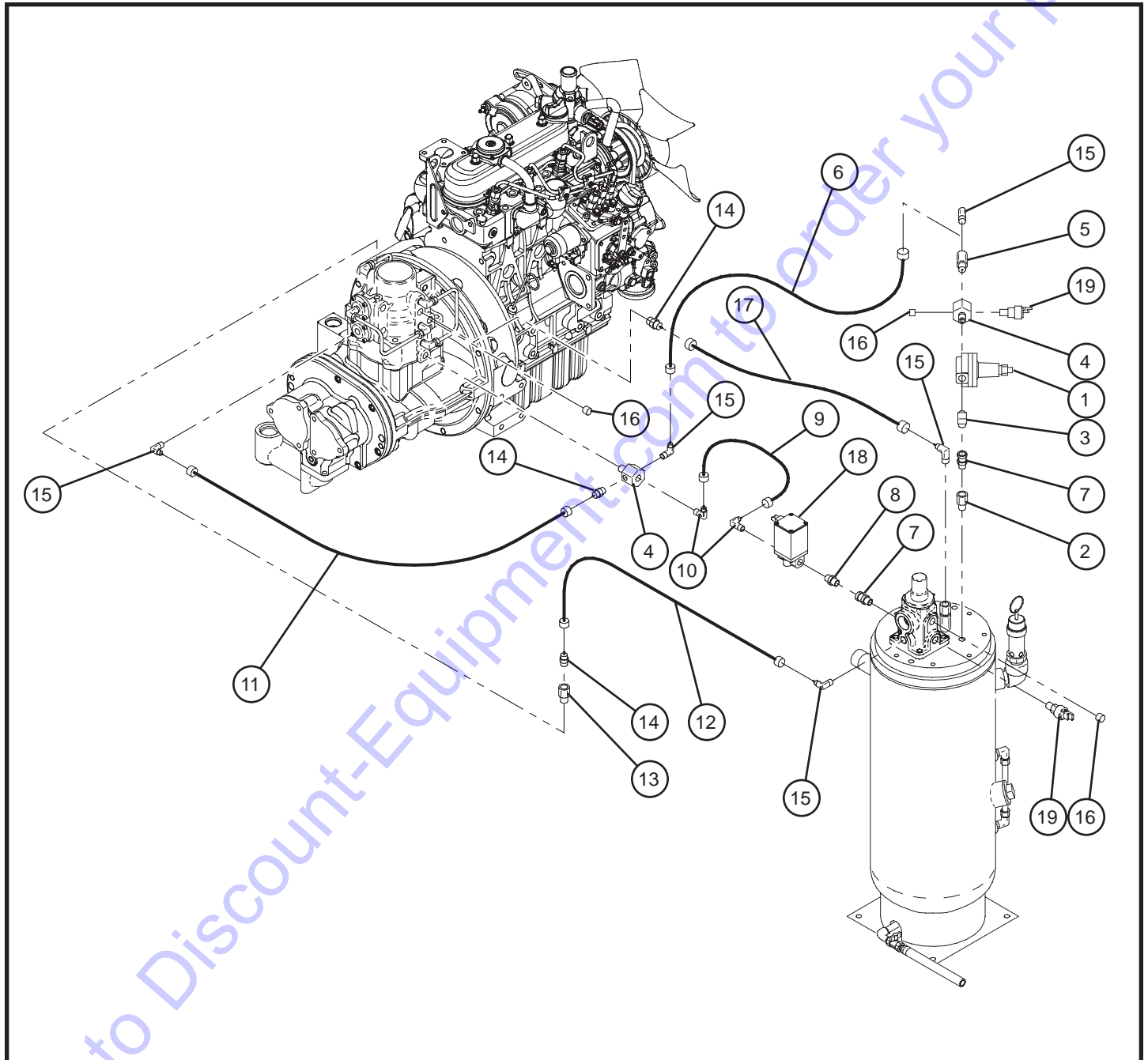

# Maxi-Air 100

SN 28-000001 and UP

## 3.4 - Air Lines

Item	Allmand No.	Part Description	Qty.
1	110590	REGULATOR ASS'Y	1
2	***	BUSHING	1
3	110591	NIPPLE ELBOW	1
4	110599	BUSHING	2
5	110806	BUSHING	1
6	***	NYLON TUBE, W/N	1
7	110592	JOINT	2
8	***	NIPPLE	1
9	***	NYLON TUBE, W/N	1
10	110825	NIPPLE ELBOW	2
11	***	NYLON TUBE, W/N	1
12	***	NYLON TUBE, W/N	1
	***	NYLON TUBE, W/N	1
13	***	BUSHING	1
14	110583	NIPPLE	3
15	110582	NIPPLE ELBOW	5
16	***	PLUG	3
17	***	NYLON TUBE, W/N	1
18	116927	SOLENOID VALVE	1
19	110545	PRESSURE SWITCH	2

NS - Not Shown

\*\*\* - Contact Allmand for more information.

Go to [Discount-Equipment.com](http://Discount-Equipment.com) to order your parts



## 3.5 - Oil Lines

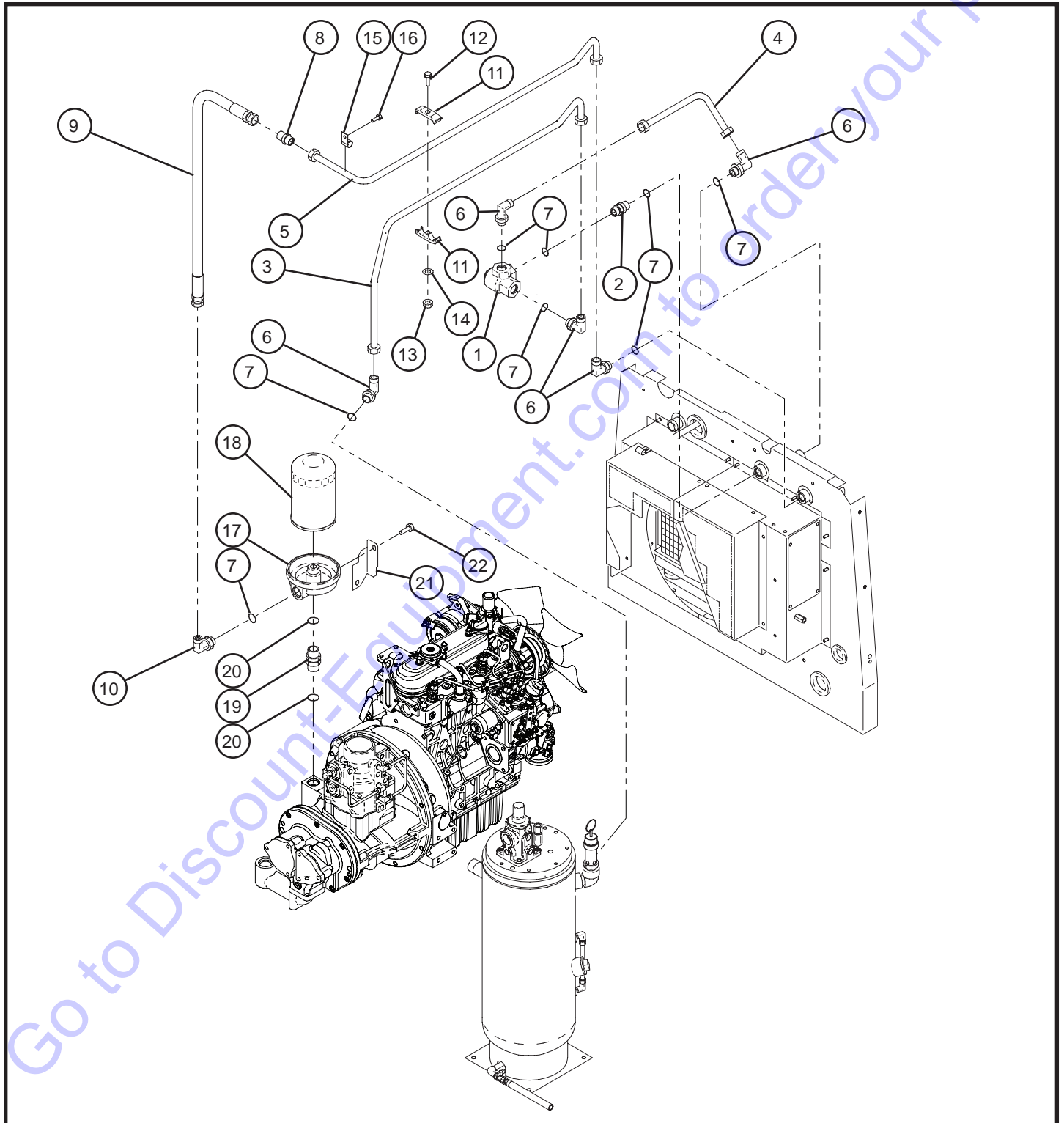

# Maxi-Air 100

SN 28-000001 and UP

## 3.5 - Oil Lines

Item	Allmand No.	Part Description	Qty.
1	***	BY-PASS VALVE ASS'Y	1
	***	PELLET ASS'Y	1
	110617	O-RING	1
2	***	NIPPLE	1
3	***	PIPE	1
4	***	PIPE	1
5	***	PIPE	1
6	***	NIPPLE	5
7	***	O-RING	7
8	***	NIPPLE	1
9	***	HOSE	1
10	***	NIPPLE ELBOW	1
11	***	BRACKET	4
	***	BRACKET	2
12	***	FLANGE BOLT	2
	***	FLANGE BOLT	1
13	***	NUT, W/W	2
	***	NUT, W/W	1
14	***	PLAIN WASHER	2
	***	PLAIN WASHER	1
15	***	CLIP	1
16	110514	FLANGE BOLT	1
17	110577	BODY	1
18	110578	FILTER CARTRIDGE	1
19	114433	NIPPLE	1
20	110584	O-RING	3
21	***	BRACKET	1
22	***	FLANGE BOLT	2

NS - Not Shown

\*\*\* - Contact Allmand for more information.

Go to [www.AllmandEquipment.com](http://www.AllmandEquipment.com) to order your parts

## 4.1 - Control Box Group

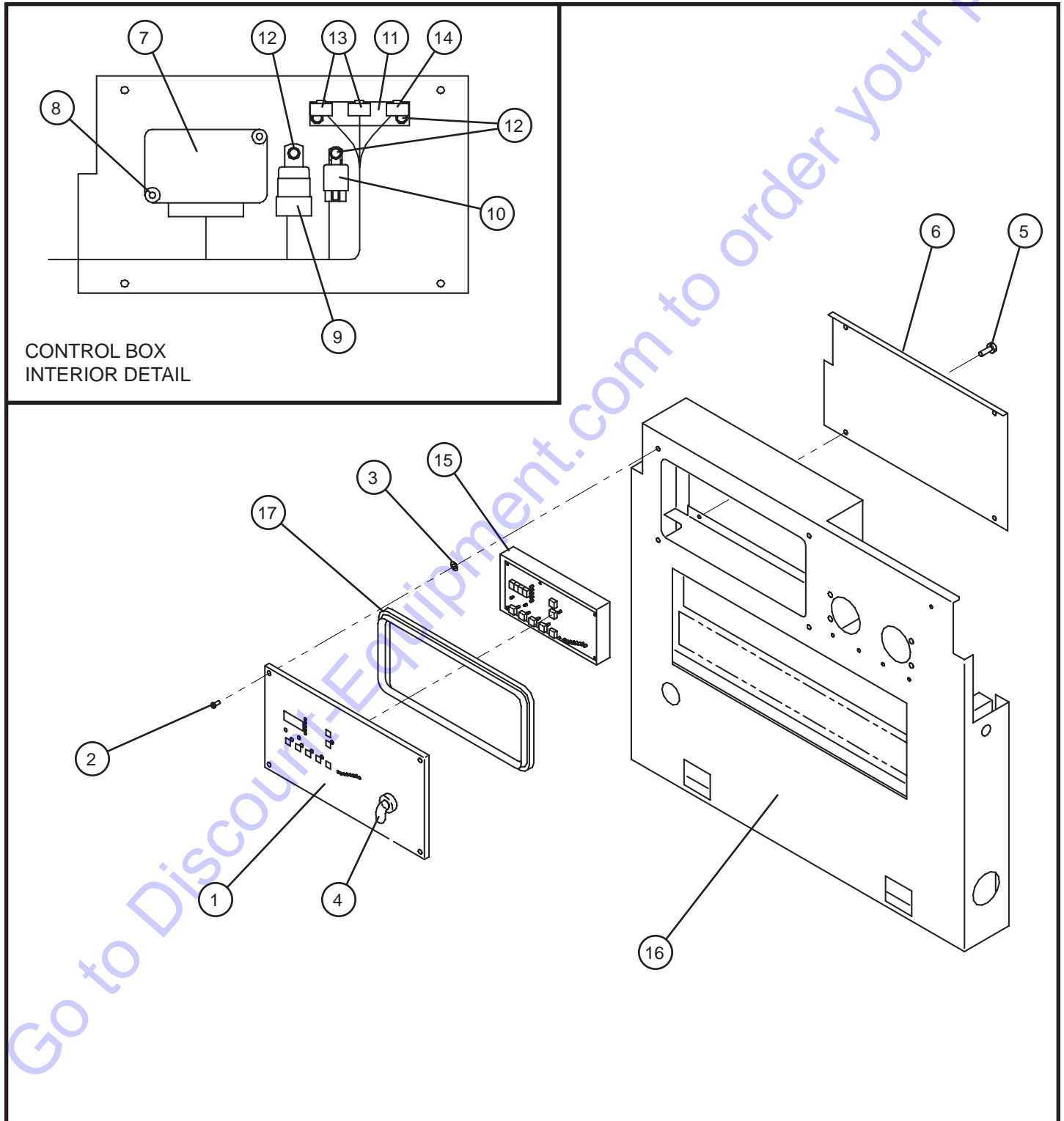

# Maxi-Air 100

SN 28-000001 and UP

## 4.1 - Control Box Group

Item	Allmand No.	Part Description	Qty.
1	***	BRACKET	1
2	***	SCREW	4
3	116411	WASHER	4
4	111685	STARTER SWITCH	1
	112921	KEY	2
5	***	COVER	1
6	110514	FLANGE BOLT	4
7	116926	CONTROLLER ECU	1
8	***	BOLT	2
	***	SPRING WASHER	2
	***	PLAIN WASHER	2
9	111683	RELAY(GLOW)	1
10	111682	RELAY(STARTER)	1
11	***	BRACKET	1
12	***	BOLT,W/W	5
13	***	FUSE BOX	2
	110904	FUSE	2
14	110662	FUSE BOX	1
	110930	FUSE	1
15	116930	CONTROLLER	1
16	***	COVER	1
17	***	SEAL RUBBER	1
NS	***	WIRING HARNESS	1

NS - Not Shown

\*\*\* - Contact Allmand for more information.

Go to [DiscountEquipment.com](http://DiscountEquipment.com) to order your parts

## 4.2 - Battery Cables Group

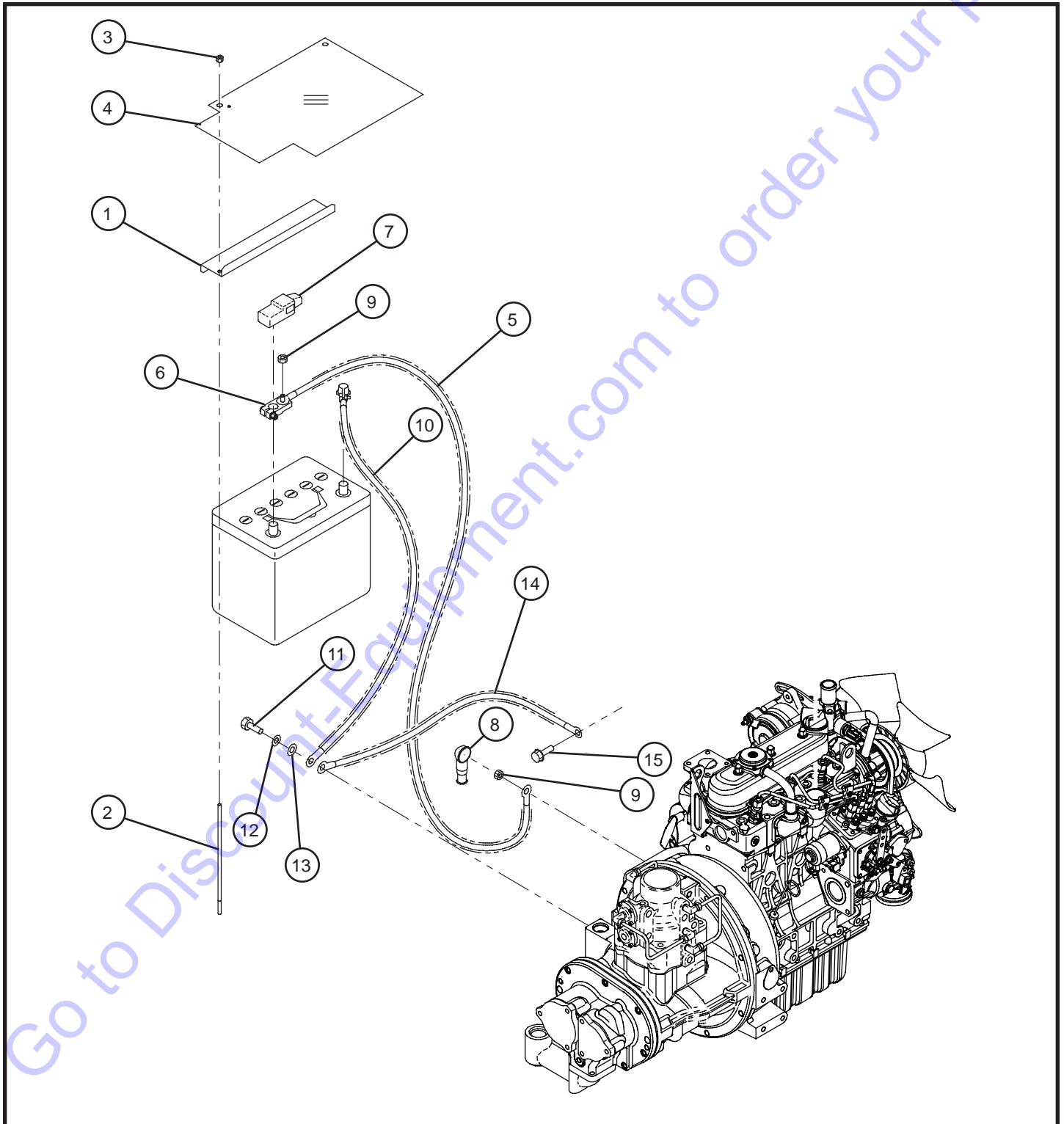

# Maxi-Air 100

SN 28-000001 and UP

## 4.2 - Battery Cables Group

Item	Allmand No.	Part Description	Qty.
1	***	COVER	1
2	***	ROD	2
3	114248	HEXAGON FLANGE NUT	2
4	***	COVER	1
5	***	CABLE	1
	***	CORRUGATED TUBE	1
6	***	TERMINAL	1
7	***	INSULATOR	1
8	***	INSULATOR	1
9	***	NUT, W/W	2
10	***	CABLE	1
	***	CORRUGATED TUBE	1
11	***	BOLT	1
12	***	SPRING WASHER	1
13	***	PLAIN WASHER	1
14	***	CABLE	1
	***	CABLE	1
	***	CORRUGATED TUBE	1
15	110515	FLANGE BOLT	1

NS - Not Shown

\*\*\* - Contact Allmand for more information.

Go to Discount-Equipment.com to order your parts

## 4.3 - Battery Charger

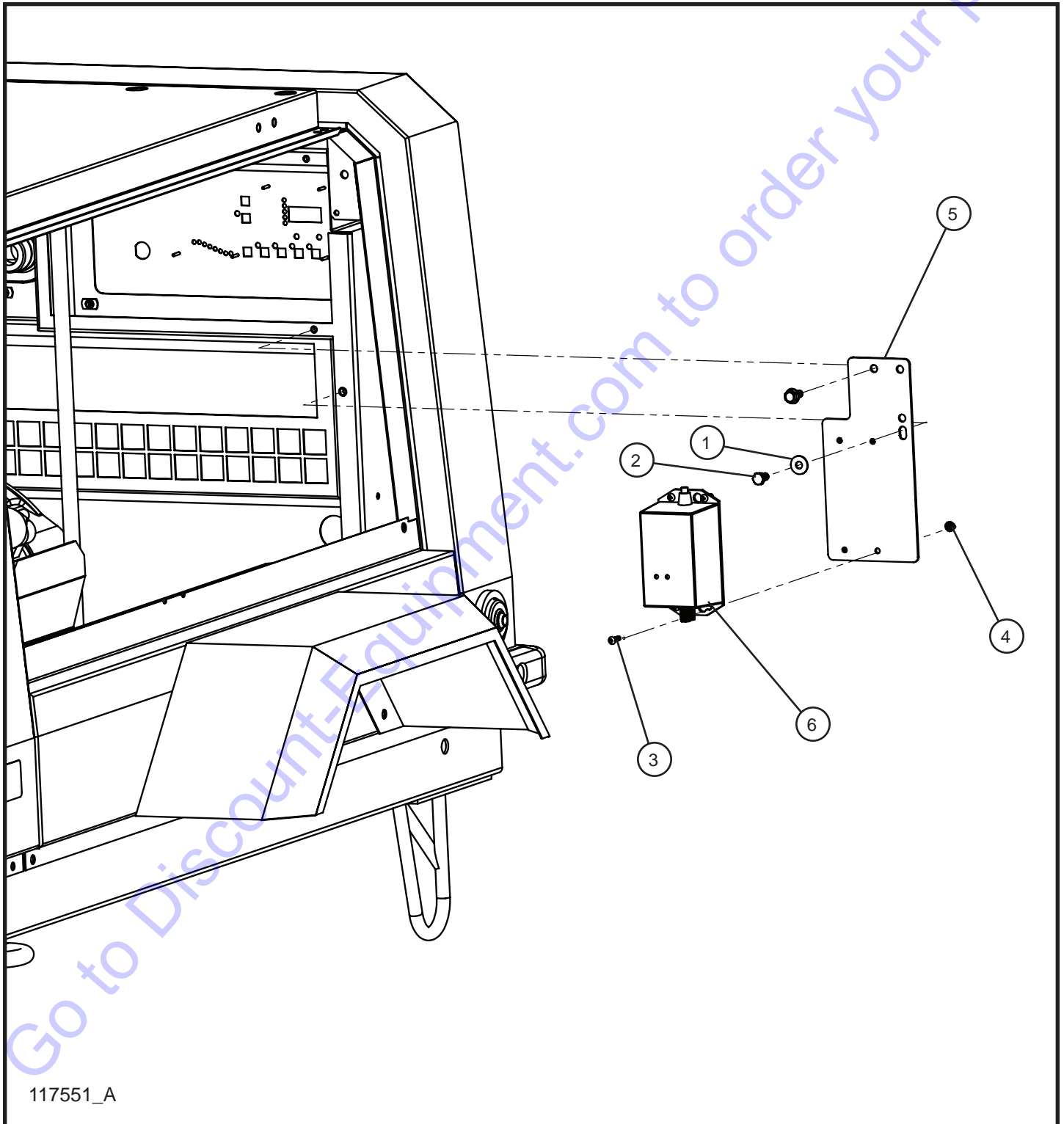

117551\_A

# Maxi-Air 100

SN 28-000001 and UP

## 4.3 - Battery Charger

Item	Allmand No.	Part Description	Qty.
1	047010	5/16 FLAT WASHER	1
2	042027	M8 x 16mm x 1.25mm HEX HEAD CS GR10.9 PL	1
3	041027	#10-24 x 3/4 PH-ROUND HEAD MS ZC	4
4	044016	#10-24 KEPS HEX NUT PL	4
5	114785P	MAXI-AIR BATTERY CHARGER MOUNT	1
6	114778	MAXI-AIR 100 & 185 BATTERY CHARGER	1
NS	022202	3/8" LOOM FLEX GUARD x 54.00	1

NS - Not Shown

\* \* \* - Contact Allmand for more information.

Go to Discount-Equipment.com to order your parts



## 4.4 - Trailer Lighting

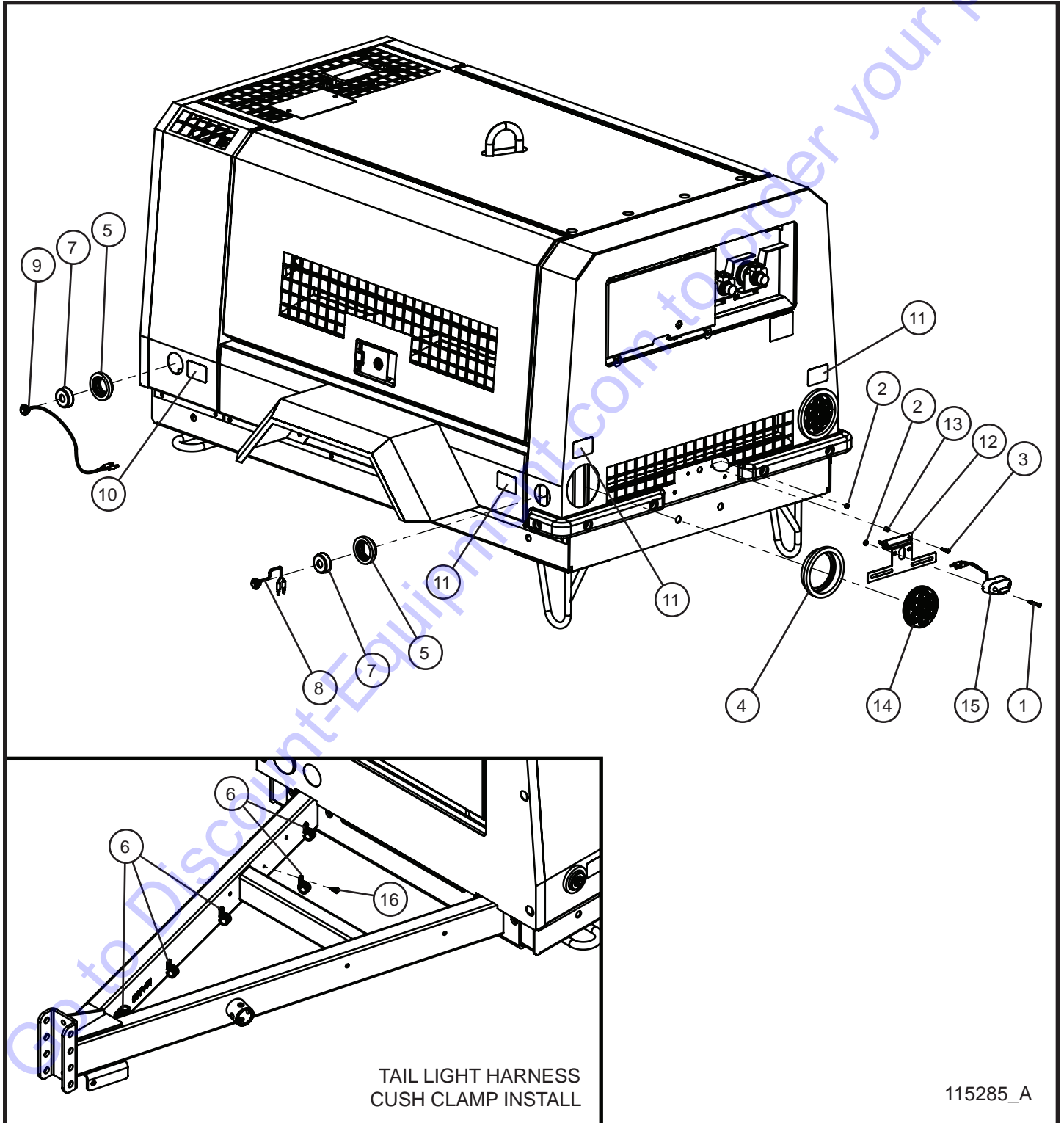

115285\_A

# Maxi-Air 100

SN 28-000001 and UP

## 4.4 - Trailer Lighting

Item	Allmand No.	Part Description	Qty.
1	041040	#10-24 x 1 1/2 PH-ROUND HEAD MACHINE SCREW	2
2	044016	#10-24 KEPS HEX NUT	4
3	041030	#10-24 x 1 PH-ROUND HEAD MACHINE SCREW	2
4	110260	GROMMET 4 INCH TAIL LIGHT	2
5	110261	GROMMET 2 INCH MARKER LIGHT	4
6	022014	#10 CUSH CLAMP	5
7	110255	ADAPTER MARKER LIGHT 2 INCH TO 3/4 INCH	4
8	106211	RED LED BULLET MARKER LIGHT	2
9	106212	RED LED BULLET MARKER LIGHT	2
10	114884	REFLECTOR DECAL AMBER 2.75 x 1.75	2
11	115286	REFLECTOR DECAL RED 2.75 x 1.75	4
12	105349P	BRACKET LICENSE PLATE	1
13	022180	SPACER RICOHO	2
14	114898	4 IN. LED LIGHT STOP TURN TAIL LIGHT	2
15	115116	LICENSE PLATE LIGHT LED	1
16	110256	TRIM PANEL RETAINER	5
NS	115282	MAXI-AIR 100 TAIL LIGHT HARNESS	1
NS	112266	MA 100, MA185, & NLV TAIL LIGHT HARNESS SCHEMATIC	1

NS - Not Shown

\*\*\* - Contact Allmand for more information.

Go to Discount-Equipment.com to order your parts

## 4.5 - Trailerless Lighting Hole Covers

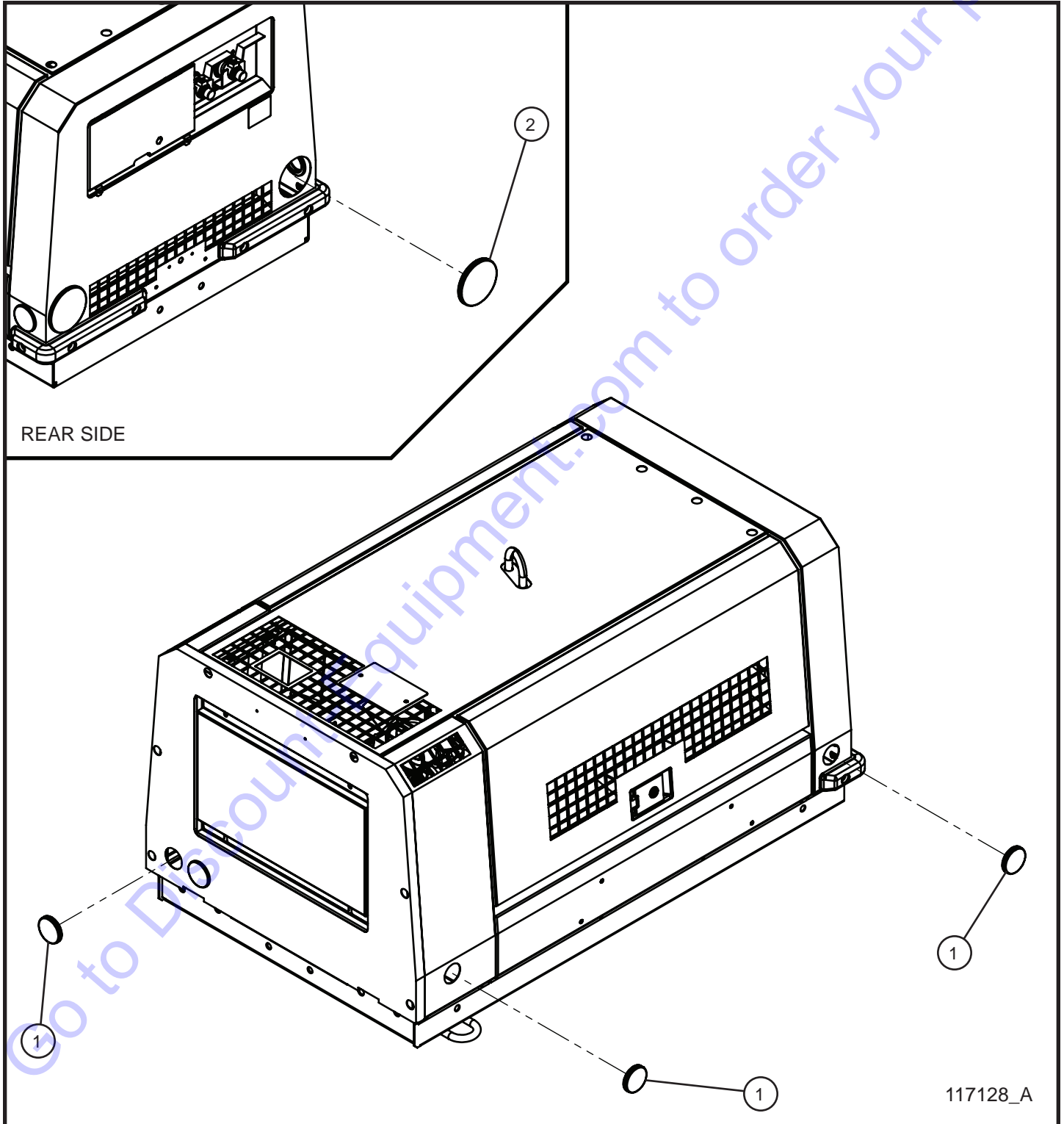

# Maxi-Air 100

SN 28-000001 and UP

## 4.5 - Trailerless Lighting Hole Covers

Item	Allmand No.	Part Description	Qty.
1	110370	GROMMET SOLID 2.047 x 2.323 x .512	5
2	112444	GROMMET SOLID 130 x 102 x 13mm	2

NS - Not Shown

\*\*\* - Contact Allmand for more information.

Go to [Discount-Equipment.com](http://Discount-Equipment.com) to order your parts

## 5.1 - Left and Right Side Enclosure Decals

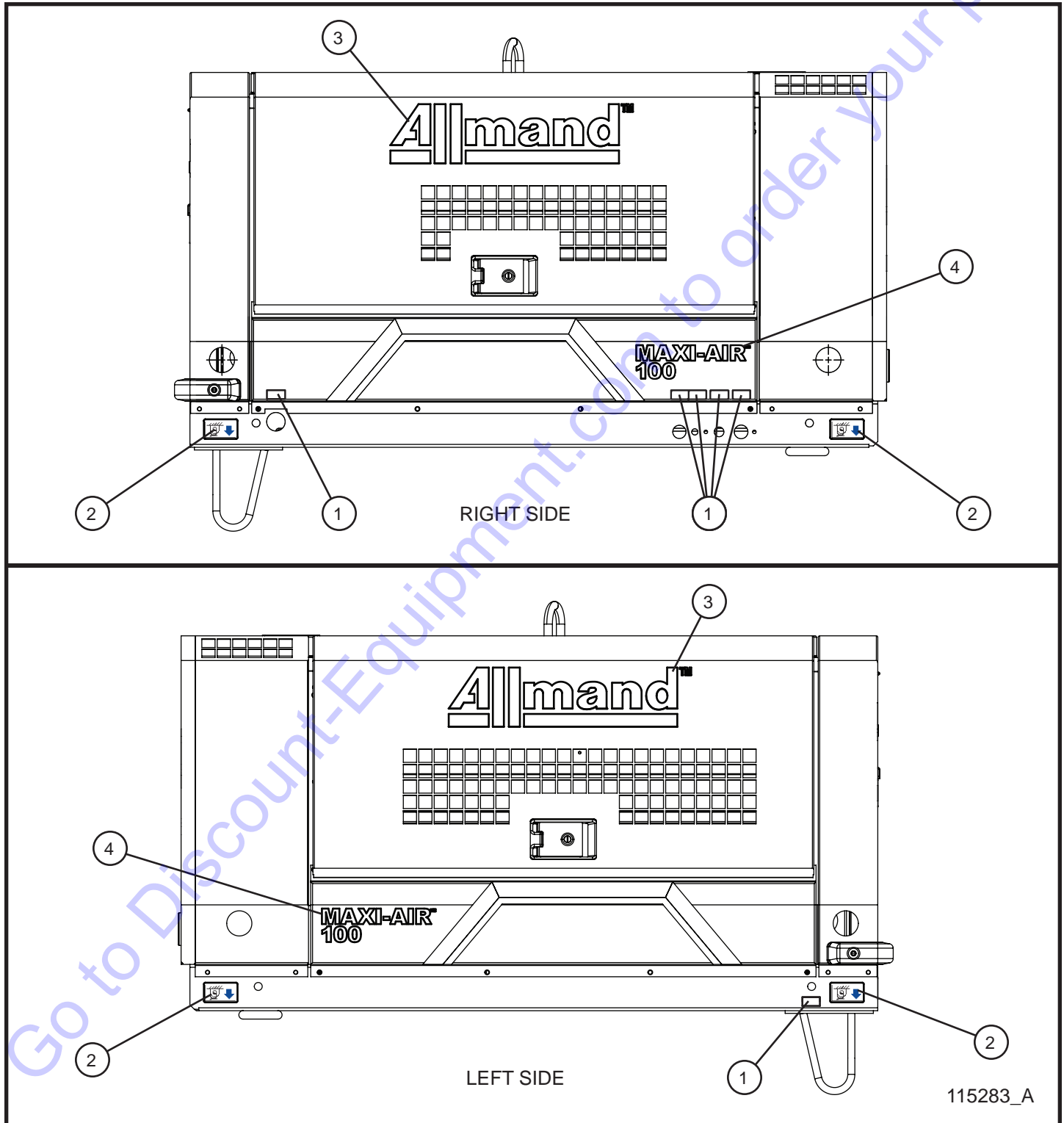

115283\_A

# Maxi-Air 100

SN 28-000001 and UP

## 5.1 - Left and Right Side Enclosure Decals

Item	Allmand No.	Part Description	Qty.
1	116869	PLATE, COMPLETE DRAIN SET	1
2	107462	TIE DOWN POSITION DECAL	4
3	110286	SMALL BLACK ALLMAND BRAND DECAL	2
4	116043	MAXI-AIR 100 STACKED DECAL	2

NS - Not Shown

\* \* \* - Contact Allmand for more information.

Go to [Discount-Equipment.com](http://Discount-Equipment.com) to order your parts

## 5.2 - Top, Front, and Rear Side Enclosure Decals

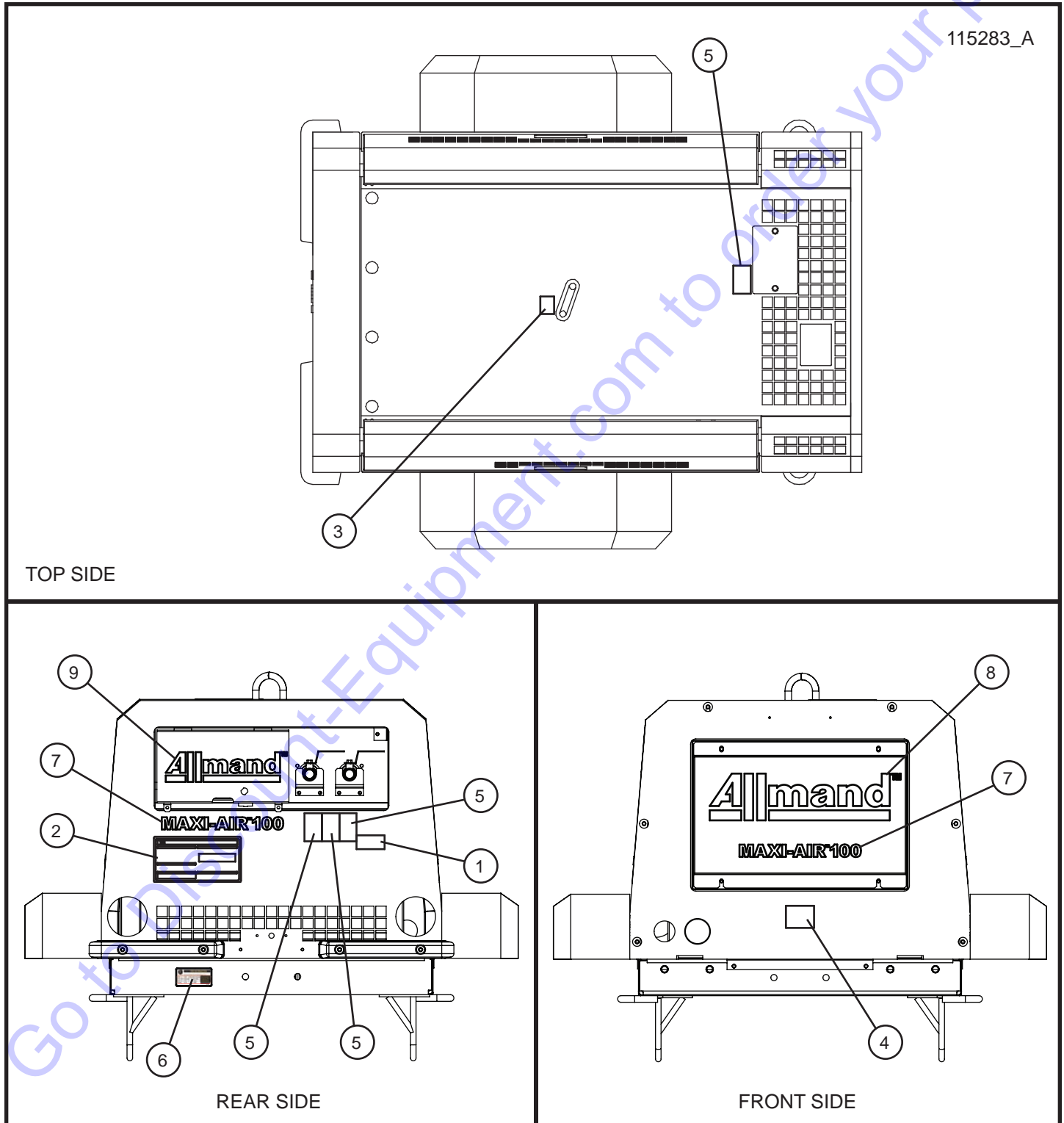

# Maxi-Air 100

SN 28-000001 and UP

## 5.2 - Top, Front, and Rear Side Enclosure Decals

Item	Allmand No.	Part Description	Qty.
1	116910	PLATE(CALIFORNIA)	1
2	116912	PLATE(START-STOP)	1
3	114400	PLATE(LIFT POSITION)	1
4	114408	PLATE(CAUTION,TOW MACHINE)	1
5	114460	PLATE,COMPLETE WARNING SET	1
6	111585	ST175/80R13 TIRE INFO DECAL	1
7	110302	MAXI-AIR 100 DECAL	2
8	110285	SMALL WHITE ALLMAND BRAND DECAL	1
9	112134	13.75 INCH WHITE ALLMAND BRAND DECAL	1
NS	116911	PLATE(IN-PANE)	1

NS - Not Shown

\*\*\* - Contact Allmand for more information.

Go to [Discount-Equipment.com](http://Discount-Equipment.com) to order your parts



## 5.3 - Tongue and Finger Guard Decals

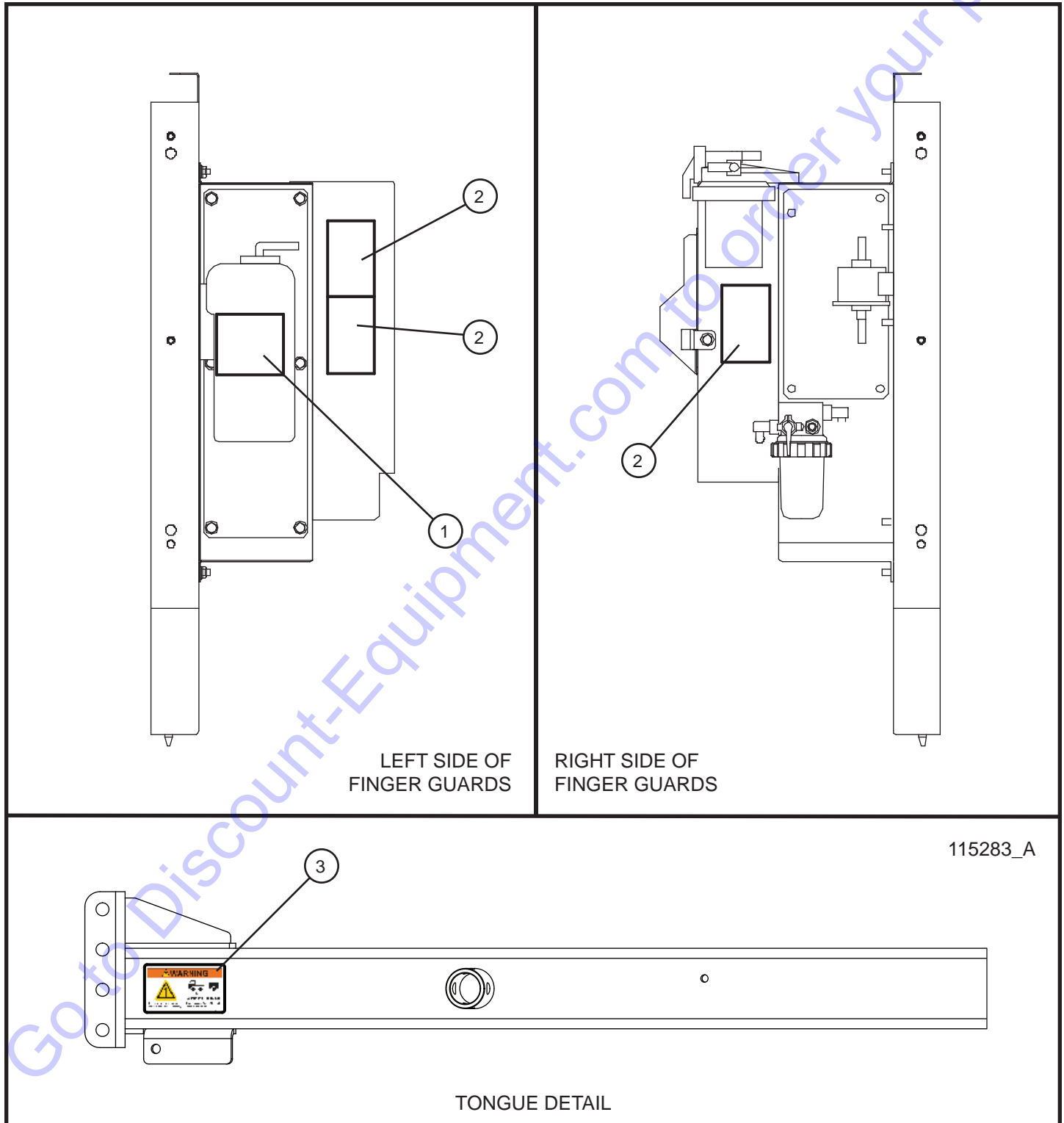

# Maxi-Air 100

SN 28-000001 and UP

## 5.3 - Tongue and Finger Guard Decals

Item	Allmand No.	Part Description	Qty.
1	116914	PLATE(LLC)	1
2	114460	PLATE,COMPLETE WARNING SET	1
3	110262	EXCESSIVE TOWING SPEED WARNING DECAL	2

NS - Not Shown

\* \* \* - Contact Allmand for more information.

Go to Discount-Equipment.com to order your parts

## 5.4 - Other Interior Decals

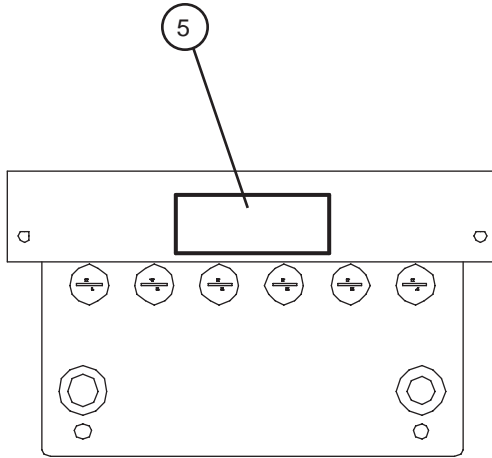

BATTERY  
DETAIL

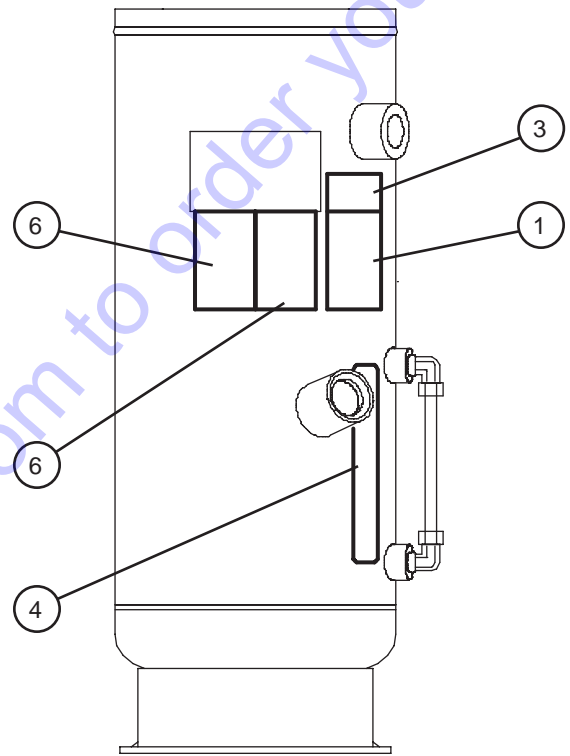

RECEIVER  
TANK DETAIL

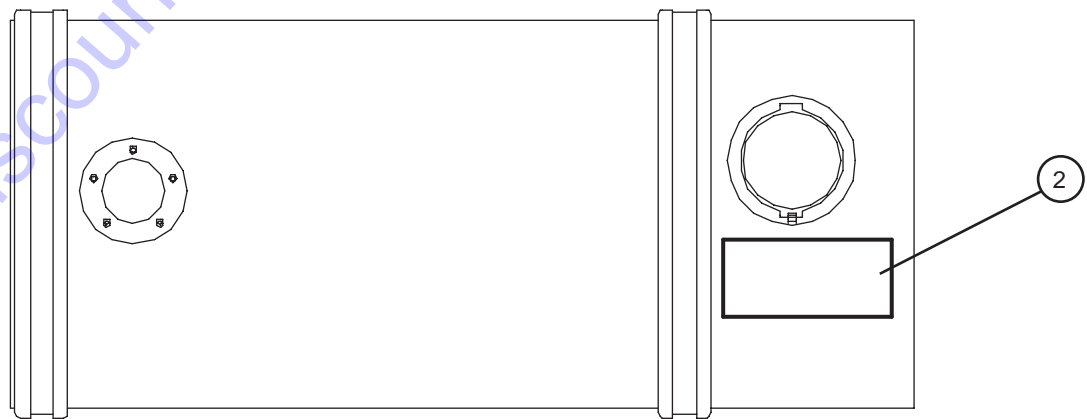

FUEL TANK DETAIL

# Maxi-Air 100

SN 28-000001 and UP

## 5.4 - Other Interior Decals

Item	Allmand No.	Part Description	Qty.
1	116913	PLATE(GENUINE OIL)	1
2	116915	PLATE(FLAMMABLES)	1
3	116867	PLATE(STRAINER)	1
4	116916	PLATE(OIL LEVEL GAUGE)	1
5	116917	PLATE(DANGER,BATTERY)	1
6	114460	PLATE,COMPLETE WARNING SET	1
NS	116911	PLATE(IN-PANE)	1

NS - Not Shown

\* \* \* - Contact Allmand for more information.

Go to Discount-Equipment.com to order your parts

# Maxi-Air 100

**Allmand**<sup>®</sup>

**Discount  
Equipment**

[www.discount-equipment.com](http://www.discount-equipment.com)

Go to [www.discount-equipment.com](http://www.discount-equipment.com) to order your parts

# PARTS FINDER

**Search Website  
by Part Number**



**Search Manual  
Library For Parts  
Manual & Lookup Part  
Numbers – Purchase  
or Request Quote**

**Search Manuals**

Enter your information to help us find the right parts manual for your machine.

\* Brand:

\* Model:

\* Serial:

\* Part Number:

SEARCH

**Can't Find Part or  
Manual? Request Help  
by Manufacturer,  
Model & Description**

**Parts Order Form**

Please fill in the following information to help us find the right part for your machine.

Manufacturer:	<input type="text"/>
Model:	<input type="text"/>
Description:	<input type="text"/>
Part Number:	<input type="text"/>
Quantity:	<input type="text"/>
Notes:	<input type="text"/>

Discount-Equipment.com is your online resource for quality parts & equipment.

Florida: **561-964-4949** Outside Florida TOLL FREE: **877-690-3101**

**Need parts?**

Click on this link: <http://www.discount-equipment.com/category/5443-parts/> and choose one of the options to help get the right parts and equipment you are looking for. Please have the machine model and serial number available in order to help us get you the correct parts. If you don't find the part on the website or on one of the online manuals, please fill out the request form and one of our experienced staff members will get back to you with a quote for the right part that your machine needs.

We sell worldwide for the brands: Genie, Terex, JLG, MultiQuip, Mikasa, Essick, Whiteman, Mayco, Toro Stone, Diamond Products, Generac Magnum, Airman, Haulotte, Barreto, Power Blanket, Nifty Lift, Atlas Copco, Chicago Pneumatic, Allmand, Miller Curber, Skyjack, Lull, Skytrak, Tsurumi, Husquvarna Target, Stow, Wacker, Sakai, Mi-T-M, Sullair, Basic, Dynapac, MBW, Weber, Bartell, Bennar Newman, Haulotte, Ditch Runner, Menegotti, Morrison, Contec, Buddy, Crown, Edco, Wyco, Bomag, Laymor, EZ Trench, Bil-Jax, F.S. Curtis, Gehl Pavers, Heli, Honda, ICS/PowerGrit, IHI, Partner, Imer, Clipper, MMD, Koshin, Rice, CH&E, General Equipment, Amida, Coleman, NAC, Gradall, Square Shooter, Kent, Stanley, Tamco, Toku, Hatz, Kohler, Robin, Wisconsin, Northrock, Oztec, Toker TK, Rol-Air, APT, Wylie, Ingersoll Rand / Doosan, Innovatech, Con X, Ammann, Mecalac, Makinex, Smith Surface Prep, Small Line, Wanco, Yanmar