



TEREX

TXC 140LC-1

Hydraulic Excavator

OPERATING WEIGHT	30,600 lbs (13,900 kg)
NET ENGINE POWER	95 hp (71 kW) @ 1,850 rpm
MAX DIG DEPTH	18' 6" (5,630 mm)
MAX REACH	27' 1" (8,260 mm)



HYDRAULIC EXCAVATOR
TXC 140LC-1

FEATURES

- Powerful, quiet, fuel efficient, turbocharged USA EPA Tier 2 compliant diesel engine maximizes power output and utilization
- e-EPOS System uses variable displacement piston pumps ensuring high efficiency and lower fuel consumption
- Swing anti-rebound valve assures quick, precise, and smooth directional stops during dumping or cradling
- Exceptional bucket break-out and radial tooth forces for toughest digging
- Spacious, comfortable cab provides excellent visibility and ergonomic operating environment
- Advanced graphic display LCD information monitor panel makes troubleshooting easier, simplifies machine performance record keeping
- Standard equipped 3-switch joystick control and hydraulic piping to boom base facilitate installation of most attachments
- Equipped to maximize operator comfort, efficiency and performance
- More standard features to make this TEREX hydraulic excavator the most productive ever

Specifications

Engine	
Model	DAEWOO DE58TIS
Type	Water-cooled, 4-cycle, direct injection, aspiration, turbocharged, air-to-air intercooled. USA EPA Tier 2 compliant.
No. of cylinders	6
Rated flywheel horsepower	
DIN 6271, net	96 PS (71 kW) @ 1,850 rpm
SAE J1349, net	95 HP (71 kW) @ 1,850 rpm
Piston displacement	353 cu. in. (5,785 cc)
Maximum torque	289 lbf.ft. (392 Nm) @ 1,850 rpm
Bore and stroke	4" x 4.6" (102 mm x 118 mm)
Starting system	24V electric motor
Batteries	2 x 12V x 100 AH

Hydraulic System	
e-EPOS (Electronic Power Optimizing System) allows the operator to maximize work efficiency over a full range of operating conditions and to minimize fuel consumption.	
Hydraulic system assures fully independent and combined operations.	
Automatic 2 speed travel system for high traction force and travel speed.	
Cross-sensing and fuel saving pump system.	
Auto idle system.	
2-Working / 2-power mode selection system.	
Computer aided engine-pump control.	
Main pumps	2 variable displacement axial piston pumps.
Max. oil flow	2 x 30.2 gpm (2 x 116 L/min)
Pilot pump	Gear pump
Max. oil flow	7.3 gpm (27.7 L/min)
Swing motor	
Relief valve	3,840 psi (265 bar)
Main relief valves	
Boom/Stick/Bucket	Normal: 4,690 psi (324 bar) Power Boost: 4,970 psi (343 bar)
Travel circuit	4,690 psi (324 bar)

Hydraulic Cylinders		
High-strength piston rods and tubes are used. Cylinder cushion mechanism is provided for all cylinders to minimize shock during operation and extend cylinder component life.		
Cylinders	Qty	Bore x Rod dia x Stroke
Boom	2	3.9" x 2.8" x 42.5" (100 x 70 x 1,080 mm)
Stick	1	4.5" x 3.1" x 42.7" (115 x 80 x 1,085 mm)
Bucket	1	3.7" x 2.6" x 34.8" (95 x 65 x 885 mm)

Superstructure Revolving Frame
Deep full-reinforced box section constructed of heavy gauge steel plates.

Operator's Cab
Cab is independent and roomy. 4 side safety glass windows give excellent visibility. Front window slides up and stores in the roof and side window can be opened for ventilation. Fully adjustable suspension seat. Air conditioner. ISO standard cab.

Noise Levels (dynamic value)	
LwA External noise	
Guaranteed Sound Power Level	103 dB(A) (95/27/EU)
Measured Sound Power Level	101.7 dB(A) (95/27/EU)
LpA Operator Noise	74 dB(A) (ISO 6396)

Controls - 2 Implement Levers
Pilot pressure control type. Right lever is boom and bucket control, left lever for swing and stick control.

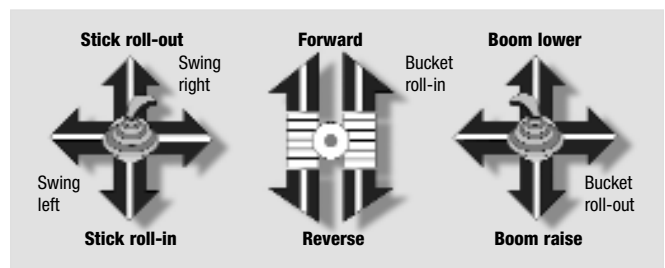

2 Travel Pedal with Levers
Pilot pressure control type. Independent drive at each track allows counter-rotation of the tracks. Levers are detachable.

Swing Mechanism	
High-torque, axial piston motor with planetary reduction gear in oil bath. Swing assembly is single row, shear type ball bearing with induction-hardened internal gear. Internal gear and pinion gear immersed in lubricant. Swing parking brake is spring-set, hydraulic-released disc type. A two position swing lock secures the superstructure for transportation.	
Swing speed	0 to 12 rpm
Rear swing radius	7' 3" (2,200 mm)

Drive	
Each track is driven by an independent, high-torque, axial piston motor through planetary reduction gearing. Two levers or foot pedal control provide smooth travel or counter-rotation upon demand.	
Travel speed (High/Low)	3.1/2.1 mph (4.9/3.4 km/h)
Maximum traction force	27,710 lbf (123 kN)
Gradeability	35° (70%) continuous

Brakes
Two oil disc brakes on final drive input shafts. Parking brake is spring-set, hydraulic-released disc type.

Specifications

Undercarriage

Tractor type undercarriage. Heavy-duty track frame, all welded stress-relieved structure. The highest grade materials are used for toughness. Side frames are welded, securely and rigidly, to the track frame. Lifetime-lubricated track rollers, idlers and sprockets with floating seals reduce field service requirements. Track shoes of induction-hardened rolled alloy with triple grousers ensure long life under the harshest applications. Specially heat-treated connecting pins reduce wear. Hydraulic track adjusters with shock-absorbing recoil springs are standard.

Number of rollers and shoes (each side) ground contact area

Upper rollers 1

(Standard Shoe)

Lower rollers 7

Track shoes 46

Overall track length 12' 4" (3,750 mm)

Weight

Equipped with 15' 1" (4.6 m) boom, 8' 2" (2.5 m) stick, and 0.76 yd³; PCSA heaped (0.58 m³) bucket.

Shoe type	Shoe width	Operating weight	Ground pressure
Triple grouser	24" (600 mm)	30,600 lb. (13,900 kg)	35 kpa, 5.1 psi
Triple grouser	28" (700 mm)	31,100 lb. (14,100 kg)	30 kpa, 4.4 psi

Standard Equipment

Hydraulic System

Boom and stick flow regeneration • Boom and stick holding valves
• Swing anti-rebound valves • Spare ports (valve) • One-touch power boost

Cab and Interior

All weather sound suppressed cab with suspension type mounts • Air conditioner (heavy duty) and heater/ defroster • Adjustable suspension seat with head rest and adjustable arm rest • Pull-up type front window and removable lower front window with storage brackets in cab
• Roof hatch/cover • Cab light • Intermittent windshield wiper • Cigar lighter and ashtray • Cup holder • Hot and cold storage container
• Graphic LCD display monitor • Fuel consumption controller • AM/FM Radio and cassette player • Remote radio ON/OFF switch • 12V spare power socket • Serial communication port for laptop PC interface
• Joystick levers with 3 switches

Other

Large handrails and steps • Punched grid-type metal anti-slip upperstructure plates • Seat belt • Sun roof (hatch) • Hydraulic safety

Service Refill Capacities

	U.S. gal	Liters
Fuel tank	60.8	230
Cooling system	5.8	22

Lubrication	U.S. gal	Liters
Engine oil	5.0	19
Swing drive (each)	0.8	3.0
Final drive (each)	0.7	2.5
Hydraulic system	43.6	165
Hydraulic tank	23.5	89

Buckets

Capacity PCSA heaped	Width		Weight	Stick Recommendation	
	without side cutters	with side cutters		8' 2" (2.5 m)	9' 10" (3.0 m)
0.37 yd ³ (0.28 m ³)	21" (528 mm)	24" (604 mm)	720 lb. (325 kg)	A	A
0.52 yd ³ (0.4 m ³)	30" (766 mm)	34" (861 mm)	790 lb. (306 kg)	A	A
0.68 yd ³ (0.52 m ³)	37" (948 mm)	41" (1,043 mm)	915 lb. (415 kg)	A	B
0.76 yd ³ (0.58 m ³)	41" (1,044 mm)	45" (1,140 mm)	950 lb. (430 kg)	A	B
0.84 yd ³ (0.64 m ³)	44" (1,124 mm)	48" (1,219 mm)	1,010 lb. (460 kg)	B	C
0.99 yd ³ (0.76 m ³)	51" (1,304 mm)	55" (1,399 mm)	1,135 lb. (515 kg)	C	–

- A. Suitable for materials with density of 3,370 lb./cu.yd. (2,000 kg/m³) or less
B. Suitable for materials with density of 2,700 lb./cu.yd. (1,600 kg/m³) or less
C. Suitable for materials with density of 1,850 lb./cu.yd. (1,100 kg/m³) or less

lock lever • Safety glass • Manual hammer mounted in cab for emergency use • Right and left rearview mirrors • Travel alarm • Heavy-duty fan guard • Dual element air cleaner • Pre-cleaner • Water separator • Double fuel filter • Radiator dust screen • Engine overheat prevention system • Engine restart prevention system • Self-diagnostic system • Heavy-duty alternator (24V, 80 amps) • Electric horn • Halogen working lights (frame mounted 2, boom mounted 2) • Hydraulic track adjuster • Sealed and greased track links • Track guards

Optional Equipment

Sun visor • Cab top/front guard (ISO 10262, FOGS standard) • Rotating beacon • Piping for hammer (one way) • Piping for optional implement rotation • Additional work lights on the cab (2 front lamps, 4 front and 2 rear lamps) • Electric fuel supply pump

Dimensions: 15' 1" (4.6 m) Boom, 8' 2" (2.5 m) Stick, 24" (600 mm) Shoe

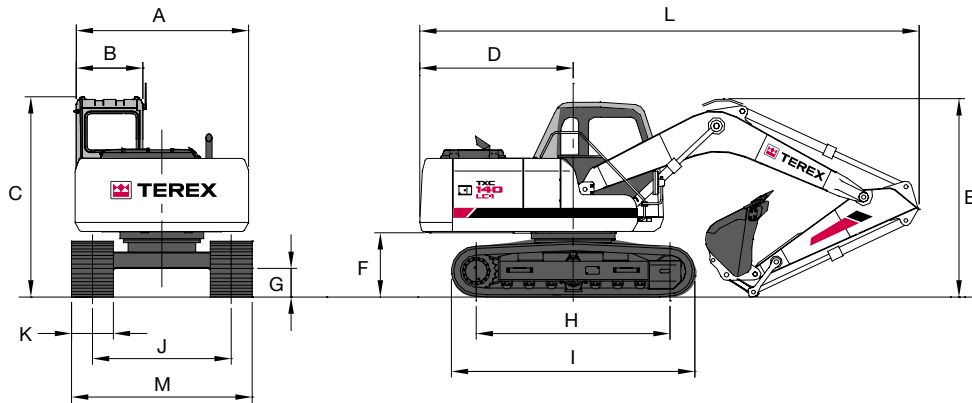

Dimensions	
A Overall width of upperstructure	8' 2" (2,490 mm)
B Overall width of cab	3' 2" (960 mm)
C Overall height of cab	9' 3" (2,830 mm)
D Tail swing radius	7' 3" (2,200 mm)
E Overall height	9' 1" (2,760 mm)
F Clearance under counterweight	3' 0" (920 mm)
G Ground clearance	1' 4" (410 mm)
H Tumbler distance	10' 0" (3,035 mm)
I Track length	12' 4" (3,750 mm)
J Track gauge	6' 6" (2,000 mm)
K Track shoe width	24" (600 mm)
L Overall length	25' 3" (7,700 mm)
M Overall track width with 24" (600 mm) shoe	8' 6" (2,600 mm)

Digging Forces (Maximum radial tooth forces)		
Stick	8' 2" (2.5 m)	9' 10" (3.0 m)
Bucket digging force*	18,300 lbf (80 kN)	18,300 lbf (81 kN)
Stick digging force*	13,900 lbf (62 kN)	12,300 lbf (55 kN)

*At power boost

Working Ranges

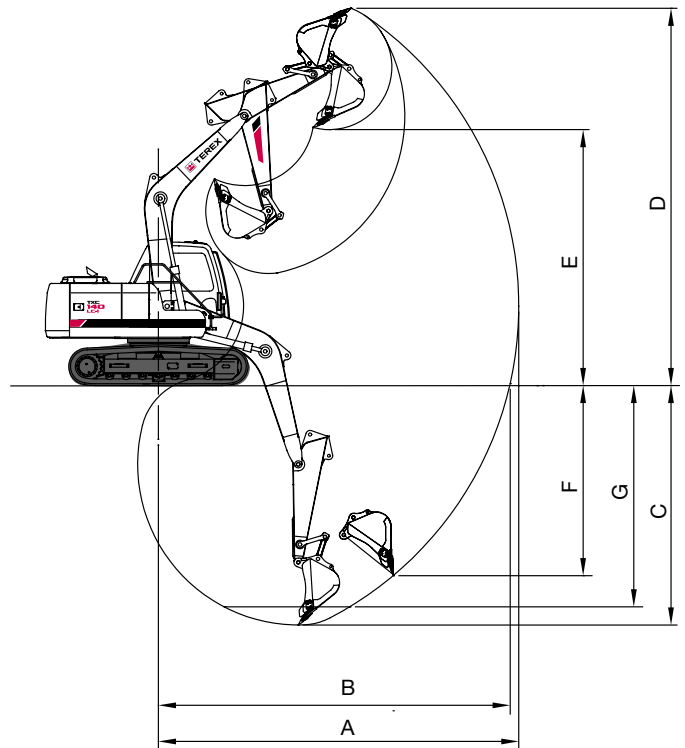

Boom Length: 15' 1" (4.6 m)		
Stick length	8' 2" (2.5 m)	15' 1" (3.0 m)
A. Max. digging reach	27' 1" (8,260 mm)	28' 8" (8,740 mm)
B. Max. digging reach at ground level	26' 7" (8,100 mm)	28' 3" (8,600 mm)
C. Max. digging depth	18' 6" (5,630 mm)	20' 1" (6,120 mm)
D. Max. digging height	28' 3" (8,620 mm)	29' 4" (8,950 mm)
E. Max. dumping height	20' 4" (6,200 mm)	21' 5" (6,530 mm)
F. Max. vertical wall digging depth	16' 8" (5,070 mm)	18' 7" (5,660 mm)
G. Max. digging depth, 8° level	17' 8" (5,380 mm)	19' 5" (5,920 mm)

Lifting Capacities

Boom: 15' 1" Stick: 8' 2" Bucket: PCSA 0.68 yd³ Shoe: 24" Weight: 34,797 lbs.

Height	Reach								unit: 1000 lb.		
	10ft F	10ft S	15ft F	15ft S	20ft F	20ft S	25ft F	25ft S	Max. F	Max. S	Reach (ft)
20 ft					*5.36	*5.36			*4.63	*4.63	@20.69
15 ft					*5.84	*5.84			*4.57	*4.57	@23.89
10 ft			*8.11	*8.11	*6.96	6.02	*5.82	4.21	*4.79	4.05	@25.59
5 ft	*8.95	*8.95	*11.68	8.83	*8.49	5.79	6.37	4.12	*5.30	3.85	@26.12
0 ft	*8.61	*8.61	13.56	8.47	8.74	5.61	6.28	4.05	6.08	3.92	@25.56
-5 ft	*13.70	*13.70	13.43	8.35	8.65	5.53			6.71	4.32	@23.83
-10 ft	*21.80	15.79	13.50	8.42	8.71	5.59			8.36	5.37	@20.59
-15 ft	*16.39	16.25							*10.32	9.02	@14.64

Boom: 15' 1" Stick: 8' 2" Bucket: PCSA 0.68 yd³ Shoe: 28" Weight: 35,238 lbs.



Height	Reach								unit: 1000 lb.		
	10ft F	10ft S	15ft F	15ft S	20ft F	20ft S	25ft F	25ft S	Max. F	Max. S	Reach (ft)
20 ft					*5.36	*5.36			*4.63	*4.63	@20.69
15 ft					*5.84	*5.84			*4.57	*4.57	@23.89
10 ft			*8.11	*8.11	*6.96	6.09	*5.82	4.27	*4.79	4.10	@25.59
5 ft	*8.95	*8.95	*11.68	8.93	*8.49	5.87	6.45	4.18	*5.30	3.90	@26.12
0 ft	*8.61	*8.61	13.73	8.57	8.85	5.68	6.37	4.10	6.16	3.97	@25.56
-5 ft	*13.70	*13.70	13.60	8.45	8.77	5.60			6.80	4.38	@23.83
-10 ft	*21.80	15.97	13.67	8.52	8.83	5.66			8.47	5.44	@20.59
-15 ft	*16.39	*16.39							*10.32	9.13	@14.64

Boom: 15' 1" Stick: 9' 10" Bucket: PCSA 0.52 yd³ Shoe: 24" Weight: 34,786 lbs.

Height	Reach								unit: 1000 lb.		
	10ft F	10ft S	15ft F	15ft S	20ft F	20ft S	25ft F	25ft S	Max. F	Max. S	Reach (ft)
20 ft					*5.55	*5.55			*4.00	*4.00	@22.83
15 ft					*6.34	6.33	*4.72	4.38	*3.93	*3.93	@25.73
10 ft			*8.26	*8.26	*7.89	6.14	*6.36	4.30	*4.08	3.71	@27.30
5 ft	*17.51	16.55	*13.15	8.99	9.04	5.89	6.43	4.19	*4.44	3.54	@27.80
0 ft	*9.14	*9.14	13.65	8.55	8.80	5.67	6.32	4.08	*5.08	3.58	@27.28
-5 ft	*12.43	*12.43	13.42	8.35	8.66	5.54	6.27	4.04	6.04	3.89	@25.68
-10 ft	*18.70	15.62	13.43	8.36	8.67	5.55			7.22	4.65	@22.74
-15 ft	*24.28	15.99	13.66	8.56					10.62	6.79	@17.67

Notes:

1. Ratings are based on SAE J1097
2. Load point is the hook on the back of the bucket.
3. *Rated loads are based on hydraulic capacity.
4. Rated loads do not exceed 87% of hyd. capacity or 75% of tipping capacity.

-  F = Rating over front
 S = Rating over side or 360 degree
 0 = Ground

Hydraulic Excavator TXC 140LC-1



Lifting Capacities

Boom: 15' 1" Stick: 9' 10" Bucket: PCSA 0.52 yd³ Shoe: 28" Weight: 35,277 lbs.

Height	Reach								unit: 1000 lb.		
	10ft F	10ft S	15ft F	15ft S	20ft F	20ft S	25ft F	25ft S	Max. F	Max. S	Reach (ft)
20 ft					*5.55	*5.55			*4.00	*4.00	@22.83
15 ft					*6.34	*6.34	*4.72	4.43	*3.93	*3.93	@25.73
10 ft			*8.26	*8.26	*7.89	6.21	*6.36	4.36	*4.08	3.76	@27.30
5 ft	*17.51	16.73	*13.15	9.09	9.15	5.96	6.52	4.24	*4.44	3.58	@27.80
0 ft	*9.14	*9.14	13.82	8.65	8.91	5.74	6.41	4.14	*5.08	3.63	@27.28
-5 ft	*12.43	*12.43	13.59	8.45	8.78	5.61	6.36	4.09	6.12	3.94	@25.68
-10 ft	*18.70	15.80	13.60	8.46	8.78	5.62			7.32	4.71	@22.74
-15 ft	*24.28	16.17	13.83	8.66					10.76	6.87	@17.67

Notes:

1. Ratings are based on SAE J1097
2. Load point is the hook on the back of the bucket.
3. *Rated loads are based on hydraulic capacity.
4. Rated loads do not exceed 87% of hyd. capacity or 75% of tipping capacity.

-  F = Rating over front
 S = Rating over side or 360 degree
 0 = Ground



For more information, product demonstration, or details on purchase, lease and rental plans, please contact your local TEREX Distributor.

TEREX Construction Americas

8800 Rostin Road
Southaven, MS 38671
USA

TEL 662-393-1800
SALES 866-837-3923
PARTS & TECH SUPPORT 888-201-6008
FAX 662-393-1700
EMAIL sales@terexca.com
WEB terexca.com

Effective date: January 1, 2005. For further information, please contact your local distributor or the TEREX sales office listed. Continuous improvement of our products is a TEREX policy. Product specifications are subject to change without notice or obligation. The photographs and drawings in this brochure are for illustrative purposes only. Refer to the appropriate Operator's Manual for instructions on the proper use of this equipment. Failure to follow the appropriate Operator's Manual when using our equipment or to otherwise act irresponsibly may result in serious injury or death. Prices and specifications subject to change without notice. The only warranty applicable is the standard written warranty applicable to the particular product and sale. TEREX makes no other warranty, expressed or implied. Products and services listed may be trademarks, service marks or trade-names of TEREX Corporation and/or its subsidiaries in the USA and other countries and all rights are reserved. "TEREX" is a Registered Trademark of TEREX Corporation in the USA and many other countries. Copyright ©2005 TEREX Corporation

TXL 140LC-1 5K 0305B Part #109272