

## Dimensions

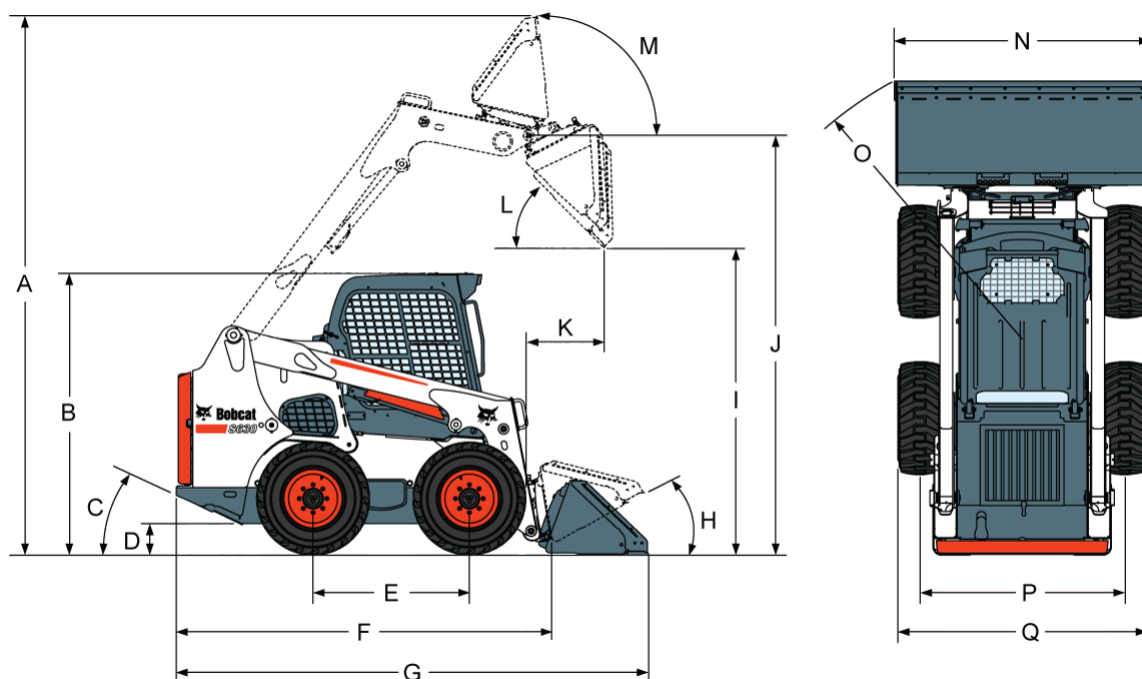

(A) Operating height	3950 mm
(B) Height with operator cab	2065 mm
(C) Angle of Departure	25°
(D) Ground clearance	406 mm
(E) Wheelbase	1150 mm
(F) Length without attachment	2754 mm
(G) Length with standard bucket	3474 mm
(H) Rollback at ground position	30°
(I) Dump height with standard bucket	2367 mm
(J) Height to bucket hinge pin	3073 mm
(K) Dump reach at maximum height	544 mm
(L) Dump angle at maximum height	42.4°
(M) Rollback fully raised at maximum height	97°
(N) Bucket width, 68-inch	1727 mm
(N) Bucket width, 74-inch	1880 mm
(N) Bucket width, 80-inch	2032 mm
(O) Turning radius with standard bucket	2119 mm
(P) Track, 12 x 16.5, 12-ply, Heavy duty tyres	1507 mm
(Q) Width over tyres, 12 x 16.5, 12-ply, Heavy duty	1832 mm

## Machine Rating

Lift breakout force	1779 daN
Tilt breakout force	1935 daN
Rated operating capacity	989 kg
Tipping load	1978 kg
Axle torque	9278 Nm

## Function Time

Raise lift arms	3.4 s
Lower lift arms	3.0 s
Bucket rollback	1.7 s
Bucket dump	2.3 s

## Weights

Operating weight	3496 kg
Shipping weight	3244 kg

## Engine

Make / Model	Kubota / V3307-DI-TE3
Fuel	Diesel
Cooling	Liquid
Power at 2400 RPM	55.4 kW
Rated speed (SAE J1 995)	2400 RPM
Torque, maximum 1600 RPM (SAE J1 995 Gross)	264 Nm
Number of cylinders	4
Displacement	3331 cm <sup>3</sup>
Bore	94 mm
Stroke	120 mm
Lubrication	Gear pump pressure
Crankcase ventilation	Closed breathing
Air filter	Dry replaceable cartridge with safety element
Ignition	Diesel-compression
Starting aid	Glow Plugs

## Electrical

Alternator	Belt driven — 90 A — open
Battery	12 V — 950 cold cranking A at -18°C — 180 min reserve capacity
Starter	12 V — gear reduction type — 3.0 kW

## Hydraulic System

Pump type	Engine driven, gear type
Pump capacity (@ 91% efficiency) at 3294 RPM	87.1 L/min
Pump capacity (@ 91% efficiency with highflow option) at 3294 RPM	115.5 L/min
System relief at quick couplers	23.8–24.5 MPa
Control valve	Three-spool, open-centre type with float detent on lift and electrically controlled auxiliary spool
Hydraulic filter	Full-flow replaceable — 10 µm synthetic media element
Fluid lines	SAE standard tubelines, hoses, and fittings

## Hydraulic Cylinders

Lift cylinder (2)	Double-acting
Lift cylinder bore	63.5 mm
Lift cylinder rod	44.5 mm
Lift cylinder stroke	860.3 mm
Tilt cylinder (2)	Double-acting with cushioning feature on dump and rollback
Tilt cylinder bore	76.2 mm
Tilt cylinder rod	41.4 mm
Tilt cylinder stroke	355 mm

## Drive System

Transmission	Infinitely variable tandem hydrostatic piston pumps, driving two fully reversing hydrostatic motors
Final drive chains	Pre-stressed #120 HSOC endless roller chain (no master link) and sprockets in sealed chaincase with oil lubrication. (Chains do not require periodic adjustments.) Two chains per side with no idler sprocket.
Main drive	Fully hydrostatic; four-wheel drive
Axle size	70.1 mm, heat treated. Axle tubes welded to chaincase. Labyrinth axle seal protection.
Wheel bolts	Eight 9/16-inch wheel bolts fixed to axle hubs

## Traction

Standard tyres	12 x 16.5, 12-ply, Bobcat heavy duty
Heavy duty offset tyres (option)	12 x 16.5, 12-ply, Bobcat heavy duty, offset rims
Float tyres (option)	33 x 15.5-16.5, 12-ply, Bobcat superflotation, offset rims
Severe duty tyres (option)	12 x 16.5, 12-ply, Bobcat severe duty
Poly fill tyres (option)	12 x 16.5, 12-ply, Bobcat severe duty, poly filled
SolidFlex tyres (option)	12 x 16.5, Bobcat solid flex
Max. travel speed (low range)	11.4 km/h
Max. travel speed (high range - option)	19.8 km/h

## Fluid Capacities

Chaincase reservoir capacity	39.2 l
Cooling system capacity without heater	11.4 l
Engine oil with filter capacity	11.4 l
Fuel tank capacity	103.3 l
Hydraulic reservoir capacity	10.2 l
Hydraulic / Hydrostatic system capacity	41.6 l

## Fluid Specifications

Engine coolant	Propylene glycol/water mix (53% – 47%) with freeze protection to -37°C 5 l can - 6904844A, 25 l container - 6904844B, 209 l drum - 6904844C, 1000 l tank - 6904844D Propylene glycol concentrate coolant 5 l can - 6987646A, 25 l container - 6987646B, 209 l drum - 6987646C, 1000 l tank - 6987646D
Engine oil	Oil must meet API Service Classification of CL4 or better. Recommended SAE viscosity number for anticipated temperature range.

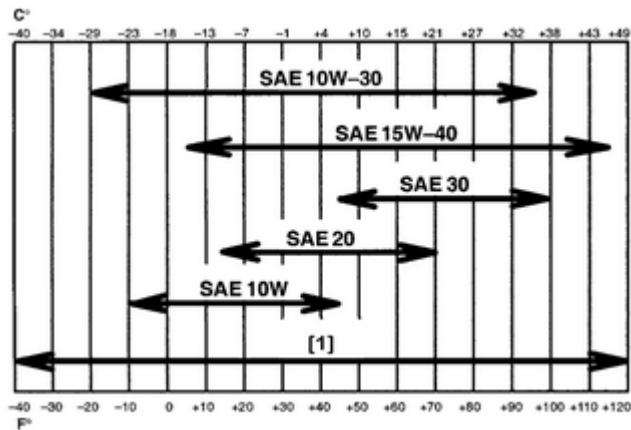

Hydraulic fluid	* Can be used only when available with appropriate diesel rating. For synthetic oil use the recommendation from the oil manufacturer. Bobcat Superior SH, 5 l can - 6904842A, 25 l container - 6904842B, 209 l drum - 6904842C, 1000 l tank - 6904842D Bobcat Bio Hydraulic, 5 l can - 6904843A, 25 l container - 6904843B, 209 l drum - 6904843C, 1000 l tank - 6904843D Motor oil is not an acceptable alternative fluid.
-----------------	--

## Controls

Engine Starting	Hand lever throttle Key-type starter switch and shutdown or optional keyless start. Glow plugs automatically activated by Standard or Deluxe instrument panel.
Front auxiliary (standard)	Electrical switch on right-hand steering lever
Rear auxiliary (optional)	Electrical switch on left-hand steering lever
Loader hydraulics tilt and lift	Separate foot pedals, optional Advanced Control System (ACS), Advanced Hand Control (AHC) or Selectable Joystick Control (SJC)
Service brake	Two independent hydrostatic systems controlled by two hand-operated steering levers
Secondary brake	One of the hydrostatic transmissions
Parking brake, standard	Mechanical disc, hand-operated rocker switch on dash panel
Parking brake, two-speed option	Spring applied pressure release multi-disk brake activated by rocker switch
Vehicle steering	Direction and speed controlled by two hand levers
Auxiliary pressure release	Pressure is relieved through the coupler block. Push in and hold for 5 s.

## Instrumentation

The following loader functions are monitored by a combination of gauges and warning lights in the operator's line of sight. The system alerts the operator of monitored loader malfunctions by way of audible alarm and visual warning lights.

### *Standard Instrument Panel*

- Gauges
  - Engine temperature
  - Fuel
- Indicators
  - Bobcat Interlock Control System
  - Engine preheat
  - Two speed
  - Turn signals
- Warning lights
  - Engine temperature
  - Fuel level
  - General warning
  - Seat belt
  - Seatbar down
  - Engine malfunction
  - Hydraulic system malfunction
  - Lift and tilt valve, hydraulics lock-out
  - Parking brake
  - Hydraulic oil temperature
  - Engine oil pressure
  - Hydraulic oil pressure
- Buttons
  - Work lights and road lights
  - High flow auxiliary hydraulics
  - Auxiliary hydraulics
  - Information
    - Hour meter (default)
    - Engine rpm
    - Battery voltage
    - Service codes
    - Service reminder (maintenance clock)
  - Traction lock override
  - Press to operate loader
- Rocker switch
  - Parking brake
- Alarm
  - Beep when error, warning or shutdown condition exists

### *Full-Color Deluxe Instrument Panel (Option)*

Same gauges, warning lights and other features as Standard Instrument Panel, plus:

- Gauges
  - Engine oil pressure / temperature
  - Hydrostatic charge pressure
  - Hydraulic oil temperature
  - Battery
- Additional features
  - Keyless start with password capability
  - Digital clock, date and time
  - User name and hourmeter
  - Attachment control information
  - Current job hours
  - High Flow lockouts
  - Multi-language display
  - Help screens
  - Diagnostic capability
  - Engine/hydraulic systems shutdown function
  - Password lockout

- Icons
  - Active warnings
  - Vitals
    - engine speed
    - oil pressure
    - temperature
    - system voltage
    - hydraulic charge pressure
    - oil temperature
  - Service
  - Main screen
  - Attachments
  - Security
  - Display
- Buttons
  - Left scroll
  - Enter
  - Right scroll

## Serviceability

Access is available to the following through the rear door/tailgate and rear screen:

- Air filter
- Alternator
- Battery
- Cooling system (engine oil and hydraulic oil coolers) for cleaning
- Engine oil and fuel filters
- Engine oil drain and dipstick
- Hydraulic oil fill and filter (access at the upper right side of the machine)
- Starter

Axle hubs provide protection for the axle seals

Bob-Tach™ pivots have replaceable wear bushings

Easy access to all lift arm grease points

Rod end of the tilt cylinder has a replaceable bushing

Tailgate has an optional lock for vandal-proofing

Tailgate is equipped with door-stop to hold door open while servicing

Tip-up operator cab gives access to certain hydraulic system components

## Standard Features

- High-back cushion suspension seat
- Automatically activated glow plugs
- Auxiliary hydraulics: variable flow/maximum flow
- Bob-Tach™ frame
- Bobcat Interlock Control System (BICS)
- Deluxe operator cab\*  
Includes interior cab foam, side, top and rear windows, Deluxe wire harness, dome light, and electrical power port, cup holder, storage place, horn
- Electrically activated proportional front auxiliary hydraulics
- Engine/hydraulics system shutdown
- Hydraulic bucket positioning (including ON/OFF switch)
- Instrumentation
- Lift arm support
- Operating lights, front and rear
- Parking brake
- Seat belt
- Seat bar
- 12 x 16.5, 12-ply, Heavy duty tyres
- CE certification
- Turbo-charger with approved spark arrestor
- Warranty: 12 months or 2000 hours

\* **Roll Over Protective Structure (ROPS)** – meets requirements of SAE-J1040 and ISO 3471; **Falling Object Protective Structure (FOPS)** - meets requirements of SAE-J1043 and ISO 3449, Level I

## Options

- Factory Options
  - Two speed
  - High-Flow hydraulics
  - Deluxe instrument panel
  - Cab enclosure with heat
  - Air conditioning
  - Power Bob-Tach™
  - 33 x 15.5-16.5, 12-ply, Superflotation tyres, offset rims
  - 12 x 16.5, 12-ply, Heavy duty tyres, offset rims
  - 12 x 16.5, 12-ply, Severe duty tyres
  - 12 x 16.5, 12-ply, Severe duty tyres, poly filled
  - 12 x 16.5, Solid flex tyres
  - Advanced Control System (ACS)
  - Advanced Hand Controls (AHC)
  - Selectable Joystick Controls (SJC)
- Dealer Installed Options
  - Block heater kit
  - Pre-cleaner HP aspiration kit
  - Deluxe instrument panel
  - Catalytic purifier kit
  - Radio kit
  - Back up alarm kit
  - Bucket positioning kit
  - Fire extinguisher kit
  - Rotating beacon kit
  - Road kit
  - Single point lift kit
  - Fresh air heater kit
  - Front door kit
  - Plumbing kit for fresh air heater
  - Keyless kit
  - Power Bob-Tach™ kit
  - Air conditioning kit
  - 200/300 lbs counterweight kit
  - Lexan rear window kit
  - Special applications front door kit
  - Four-point lift kit
  - 7 and 14-pin electrical attachment control kit (7-pin kit standard with S630H)
  - FOPS kit \*\*
  - Rear auxiliary hydraulic kit

\*\* Falling Objects Protective Structure (FOPS) – meets requirements of SAE-J1043 and ISO 3449, Level II



## Attachments

For specific model availability, see Bobcat Product Price List.

- Angle broom\*†
- Auger
- Backhoe
- Bale forks
- Box blade
- Brushcat rotary cutter
- Buckets
- Chipper\*
- Combination bucket
- Concrete pump\*
- Cutter crusher\*
- Digger
- Dozer blade\*
- Dumping hopper
- Farm grapple
- Flail cutter
- Grader\*
- Hydraulic breaker\*\*
- Industrial grapple
- Landplane
- Landscape rake
- Mixing bucket
- Mower
- Over-the-tyre tracks
- Pallet fork – hydraulic
- Pallet fork – standard
- Planer\*†
- Rear stabilisers
- Scarifier
- Snow blade
- Snow blower\*
- Snow V-blade
- Sod layer\*
- Soil conditioner\*
- Spreader
- Stump grinder\*
- Super scraper
- Sweepert†
- Three-point hitch
- Tiller
- Tilt-Tatch™
- Tree transplanter\*
- Trench compactor
- Trencher
- Utility forks
- Utility frame
- Vibratory roller
- Water kit
- Wheel saw\*
- Whisker broom

\*Attachment control kit required.

\*\*When operating the loader with this attachment, a Special Applications Kit must be used.

†Optional water kit.

## Environmental

Operator $L_{pA}$ (98/37 & 474-1)	85 dB(A)
Noise level $L_{WA}$ (EU Directive 2000/14/EC)	101 dB(A)
Whole body vibration (ISO 2631-1)	0.64 $ms^{-2}$
Hand-arm vibration (ISO 5349-1)	1.58 $ms^{-2}$

## Safety

Bobcat Interlock Control System (BICS), standard	Requires the operator to be seated in the loader with the seat bar in place and the engine running. After the operator presses the "Press to Operate Loader" button, the loader's hydraulic lift and tilt functions and traction drive can be operated.
Lift arm bypass control, standard	Used to lower the lift arms in the event that the lift arms cannot be lowered during normal operating conditions.
Seat belt, standard	Should always be worn when operating the loader. Three-point shoulder belt provides restraint for high range speeds.
Seat bar, standard	Secondary operator restraint, also serves as an arm rest.
Operator cab, standard	An enclosed operator cab with side screens with a minimal inside cab width of 838 mm. Meets SAE-J1040 and ISO 3471 for Roll Over Protective Structure (ROPS) and SAE-J1043 and ISO 3449 Level I * for Falling Objects Protective Structure (FOPS). Level II ** option is available.
Lift arm support, standard	Use for servicing when lift arms are raised.
Parking brake, standard	Always set brake when leaving loader.
Grab handles, standard	Should always be used when entering/exiting loader.
Safety tread, standard	Slip resistant tread on lift arms and main frame to be used when entering/exiting loader.
Attachment steps, standard	Should always be used when entering/exiting loader.
Rear window, standard	For emergency exit.
Front and rear working lights, standard	Use for indoor and low light operation.
Backup alarm, optional	For use in areas with high traffic
Lift kits, optional	Lift kits are available so loader may be lifted into remote areas.
Special applications kit, optional	Restricts objects and material from entering cab openings.
Operator's handbook, standard	Weather-resistant operator handbook attached to the inside of the cab, providing operational instructions and warnings decals with pictorials and international symbols.

\* Level I — Acceptance is intended for protection from falling bricks, small concrete blocks, and hand tools encountered in operations such as highway maintenance, landscaping, and other construction site services.

\*\* Level II — Acceptance is intended for protection from falling trees or rocks for machines involved in site clearing, overhead demolition, or forestry.