

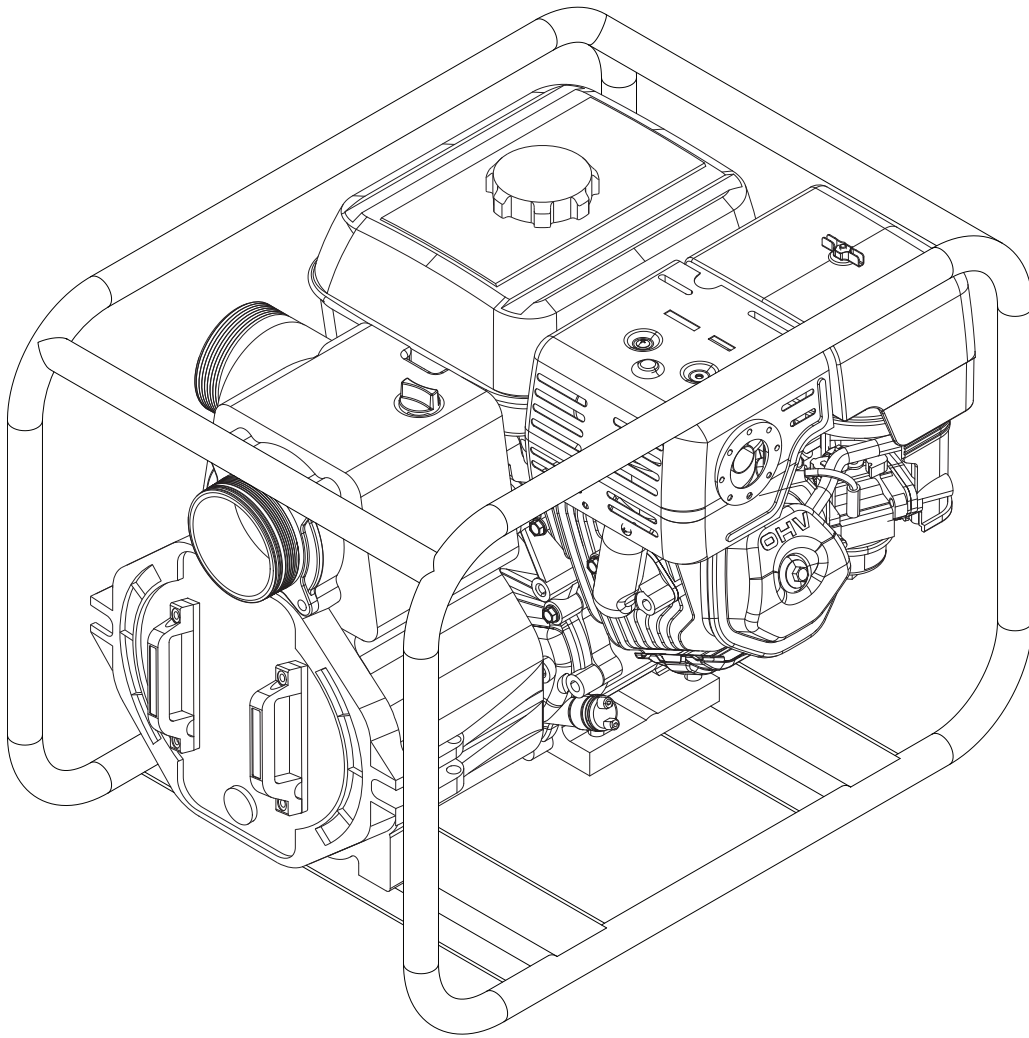

PORTABLE TRASH PUMPS
MTP400



OPERATING & PARTS MANUAL

INTRODUCTION

This manual provides information and procedures to safely operate and maintain the engine and pump. For your own safety and protection from physical injury, carefully read, understand, and observe the safety instructions described in this manual. *The information contained in this manual was based on machines in production at the time of publication. Magnum Products LLC reserves the right to change any portion of this information without notice.*

DO NOT MODIFY or use this equipment for any application other than which it was designed for.

Magnum Products LLC recommends that a trained and licensed professional perform all electrical wiring and testing functions. Any wiring should be in compliance with the United States National Electric Code (NEC), state and local codes and Occupational Safety and Health Association (OSHA) guidelines.

Keep a copy of this manual with the unit at all times. Additional copies are available from Magnum Products LLC, or can be found at www.m-p-llc.com. An engine operator's manual was also supplied with the unit at the time of shipment from the factory. The manual provides detailed operation and maintenance procedures for the engine. Additional copies of the engine operator's manual are available from the engine manufacturer.

MAGNUM PRODUCTS LLC
215 Power Drive • Berlin, WI 54923
U.S.A.
Phone: 920-361-4442
FAX: 920-361-4416
Toll Free: 1-800-926-9768
www.m-p-llc.com

For technical or parts **QUESTIONS**, please contact Magnum Products' Customer Support or Technical Support team at 920-361-4442 or toll free at 1-800-926-9768. Please have your serial number available.

To **ORDER SERVICE PARTS**, please contact the dealer from which you purchased the unit, or call Magnum Products to locate a dealer in your area.

Supplemental information may be available for your unit; when ordering parts **ALWAYS** check for a supplement that applies to your unit. A supplement may have been provided with your unit and can be found on the Magnum Products LLC website.

Engine Make: _____
Engine Serial Number: _____
Engine Model Number: _____
Unit Model Number: _____
Unit Serial Number: _____

▲ **WARNING**

CALIFORNIA PROPOSITION 65 WARNING: Engine exhaust and some of its constituents are known to the state of California to cause cancer, birth defects and other reproductive harm.

TABLE OF CONTENTS

	Page
INTRODUCTION	2
TABLE OF CONTENTS	3
SAFETY NOTES	4
OPERATING SAFETY	4
ENGINE SAFETY	5
UNIT SERIAL NUMBER LOCATION	6
SAFETY SYMBOL SUMMARY	6
SPECIFICATIONS	7
COMPONENT LOCATIONS	8
HOSE RECOMMENDATIONS	8
STARTING THE PUMP	9
OPERATING THE PUMP	9
STOPPING THE PUMP	9
MAINTENANCE SCHEDULE	10
DAILY MAINTENANCE CHECKS AND TIPS	10
ADDING ENGINE OIL	11
CLEANING THE PUMP	11
STORING THE PUMP	11
UNIT ASSEMBLY AND PARTS	12 - 13
UNIT DECALS	14
NOTES	15

SAFETY NOTES



This is the safety alert symbol. It is used to alert you to potential personal injury hazards. Obey all safety messages that follow this symbol to avoid possible injury or death.

This manual contains DANGERS, WARNINGS, CAUTIONS, NOTICES and NOTES which must be followed to prevent the possibility of improper service, damage to the equipment, personal injury or death. The following formatting options will apply when calling the readers attention to the DANGERS, WARNINGS, CAUTIONS, NOTICES and NOTES.

▲ DANGER

INDICATES A HAZARDOUS SITUATION WHICH, IF NOT AVOIDED, WILL RESULT IN DEATH OR SERIOUS INJURY.

▲ WARNING

Indicates a hazardous situation which, if not avoided, could result in death or serious injury.

▲ CAUTION

Indicates a hazardous situation which, if not avoided, may result in minor or moderate injury.

NOTICE

Indicates a hazardous situation which, if not avoided, may result in property or equipment damage.

***Note:** Notes contain additional information important to a procedure and will be found within the regular text body of this manual.*

OPERATING SAFETY



Before using the pump be sure to read and understand all of the instructions! This equipment was designed for specific applications; DO NOT modify or use this equipment for any application other than which it was designed for. Equipment operated improperly or by untrained personnel can be dangerous! Read the operating instructions and familiarize yourself with the location and proper use of all instruments and controls. Inexperienced operators should receive instruction from someone familiar with the equipment before being allowed to operate or set up the pump. The following points should be practiced at all times:

- The area immediately surrounding the pump should be dry, clean, and free of debris.
- **NEVER** start a unit in need of repair.
- **NEVER** operate on a combustible surface.
- **NEVER** operate the pump if any of the following conditions exist during operation:
 1. Noticeable change in engine speed.
 2. Sparking occurs.
 3. Engine misfires or there is excessive engine vibration.
 4. Protective covers are loose or missing.

▲ WARNING

Never pump volatile or corrosive chemicals or solutions with this pump. These fluids could create serious safety, health and environmental hazards. High pressure increases the chance of pump explosion which may result in serious personal injury.

ENGINE SAFETY



Internal combustion engines present special hazards during operation and fueling! Failure to follow the safety guidelines described below could result in severe injury or death. Read and follow all safety warnings described in the engine operator's manual. A copy of this manual was supplied with unit when it was shipped from the factory.

- **DO NOT** run engine indoors or in an area with poor ventilation. Engine exhaust contains carbon monoxide, a deadly, odorless and colorless gas which, if inhaled, can cause nausea, fainting or death. Only use this unit outside and away from windows, doors and ventilation equipment.
- **DO NOT** fill fuel tank near an open flame, while smoking, or while engine is running. **DO NOT** fill tank in an enclosed area with poor ventilation.
- **DO NOT** operate with the fuel tank cap loose or missing.
- **DO NOT** touch or lean against hot exhaust or engine parts.
- **DO NOT** clean air filter with gasoline or other types of low flash point solvents.
- Keep hands, feet and loose clothing away from moving parts on the engine.

UNIT SERIAL NUMBER LOCATION

Refer to the location illustrated below to find the unit ID tag. Important information, such as the unit serial and model numbers are found on this tag. Record the information from this tag, so it is available if the tag is lost or damaged. When ordering parts or requesting technical service information, you may be asked to specify this information.

Unit ID Tag

ARGNUM	
<small>210 Power Drive • Seattle, WA 98103 1-800-426-8784</small>	
MODEL	_____
UNIT ID	_____
SERIAL NUMBER	_____
LOGBOOK	_____
WEIGHT	_____
IN	_____
LB	_____
FLOW	_____
GPM	_____
GPH	_____
CONNECTION SIZE	_____
IN	_____
TOTAL HEAD	_____
FT	_____
<small>DO NOT RUN PUMP DRY</small>	

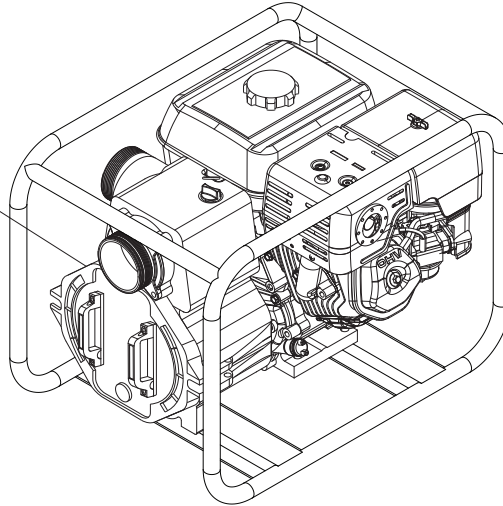

SAFETY SYMBOL SUMMARY

This equipment has been supplied with numerous safety and operating decals. These decals provide important operating instructions and warn of dangers and hazards. Replace any missing or hard-to-read decals and use care when washing or cleaning the unit. Decal placement and part numbers can be found on page 14 of this manual. Below is a summary of the intended meanings for the symbols used on the decals.

	Safety alert symbol; Used to alert you to potential personal injury hazards.		Asphyxiation hazard; Operate in well ventilated area.
	Hot surface(s) nearby.		Use unleaded gasoline only.
	Two-person lift only.		Fire/explosion hazard; Keep open flames away from unit.
	Burn/scald hazard; pressurized steam.		Read and understand the supplied operator's manual before operating unit.
	Stop engine before fueling.		Impeller hazard.

SPECIFICATIONS

Read this manual carefully before attempting to use this pump. The potential for property damage, personal injury or death exists if this equipment is misused or installed incorrectly. Read all of the manuals included with this unit. Each manual details specific information regarding items such as set-up, use and service requirements. **Specifications are subject to change without notice.**

MAGNUM MODEL

MTP400

Pump Output

Suction/Discharge Diameter	4 in. (10.1 cm)
Maximum Discharge Head.....	95 ft. (29 m)
Maximum Suction Head.....	26 ft. (7.6 m)
Maximum Discharge	569 gpm (2154 Lpm)

Engine Specifications

Engine Make	Honda
Engine Model	GX340
Net Power Rating*	9.5 hp (7.1 kW)
Approximate Run Time	2.4 hours

Capacities

Fuel Tank	1.6 gal (6.1 L)
-----------------	-----------------

Weights and Dimensions

Dry Weight	151 lbs. (69 kg)
Operating Weight	162 lbs. (73 kg)
Dimensions (L x W x H)	28.9 x 19.0 x 22.4 in. 734 x 483 x 569 mm

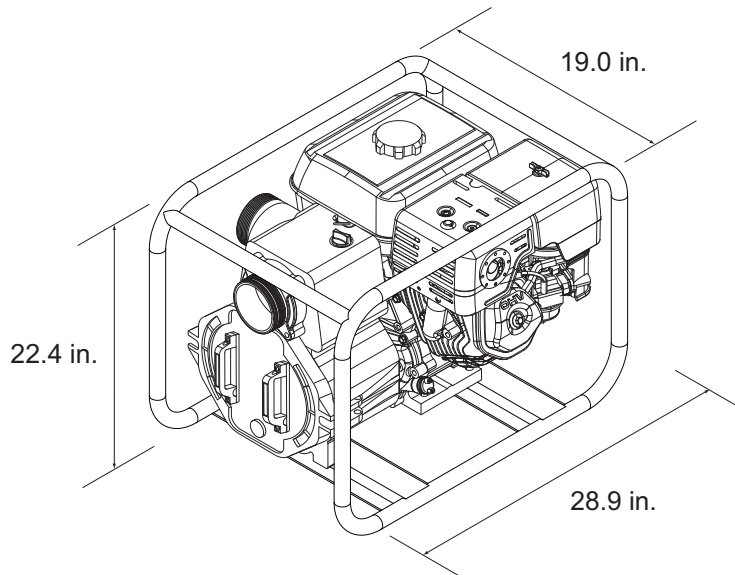

* The power rating of the engine indicated in this document is the net power output tested on a production engine for the engine model and measured in accordance with SAE J1349 at 3600 rpm. Mass production engines may vary from this value. Actual power output for the engine installed in the final machine will vary depending on numerous factors, including the operating speed of the engine in application, environmental conditions, maintenance, and other variables.

COMPONENT LOCATIONS

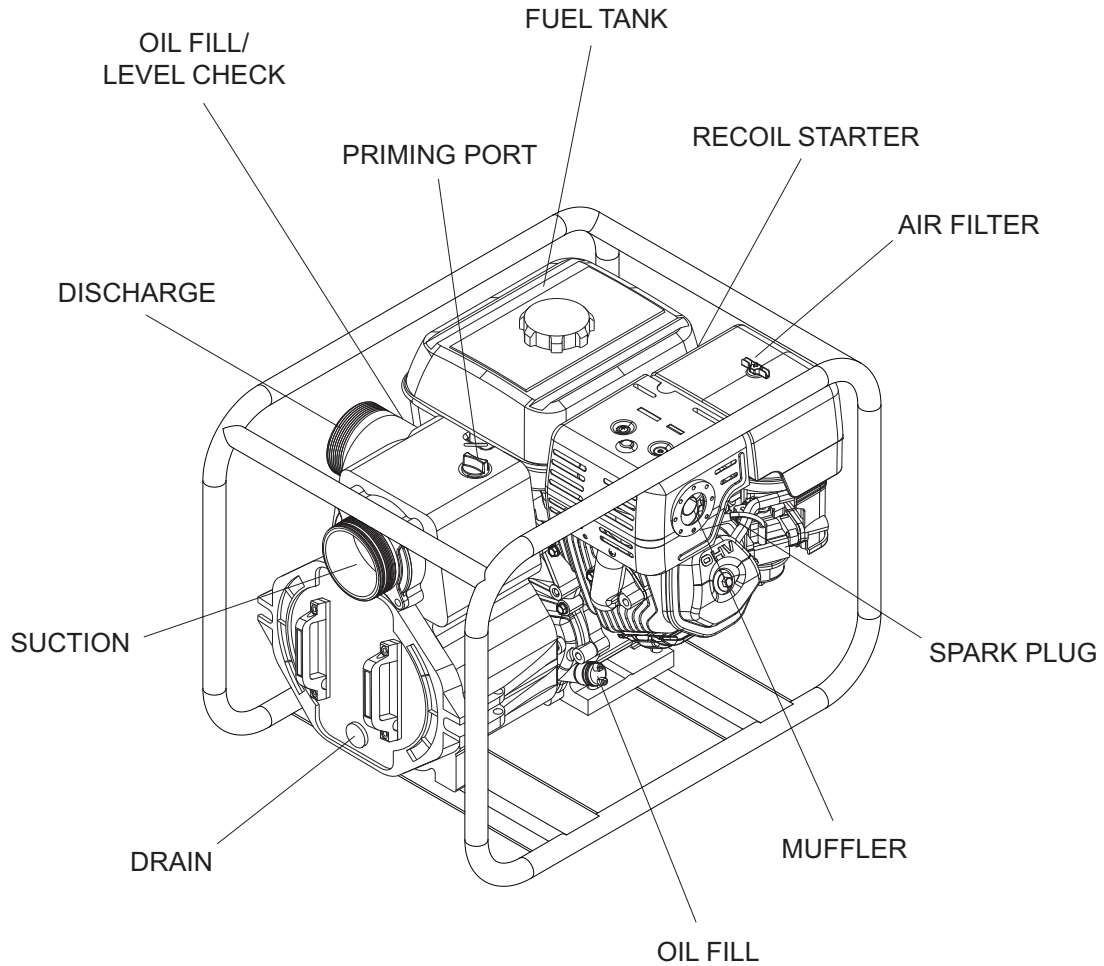

HOSE RECOMMENDATIONS

HOSES

- Suction hoses must be rigid enough not to collapse when pump is operating.
- Discharge hoses need to be thin-walled and collapsible. Rigid hoses may also be used as discharge hoses.

Note: A small air leak from the suction hose will prevent the pump from priming. Be sure to properly connect and secure the hose clamps before running the pump.

STARTING THE PUMP

Before starting the pump, add engine oil and gasoline. See page 11 for instructions on how to properly fill the unit with engine oil.

1. Attach suction and discharge hoses.

⚠ DANGER

CARBON MONOXIDE: USING A GENERATOR INDOORS CAN KILL YOU IN MINUTES!

2. Fill up pump casing with water by removing the fill cap on top of the pump.
3. Open the fuel valve.
4. Turn engine switch on.
5. Open the throttle.
6. Pull starter rope.
7. As engine begins to warm-up, open choke.
8. Open throttle fully to operate.

OPERATING THE PUMP

The pump should begin pumping water within a minute. The longer the suction hose and higher the pump is above water, the more time it will take to begin pumping.

If the pump does not prime, check for loose fittings or air leaks in the suction hose. Make sure strainer in water is not blocked.

⚠ WARNING

Never pump volatile or corrosive chemicals or solutions with this pump. These fluids could create serious safety, health and environmental hazards. High pressure increases the chance of pump explosion which may result in serious personal injury.

STOPPING THE PUMP

1. Reduce engine rpm to idle by moving throttle to the right.
2. Turn engine switch off.
3. Close fuel valve.

MAINTENANCE SCHEDULE

The following maintenance schedule should be followed to ensure proper performance of the unit.

ITEM	DAILY	20 HRS.	50 HRS.	100 HRS.	500 HRS.
Visual walk around inspection	◆				
Check engine oil level	◆				
Check air filter	◆				
Check external hardware	◆				
Inspect hoses and housing for leaks	◆				
Change engine oil		◆*		◆	
Clean air filter			◆		
Check and adjust spark plug				◆	
Clean muffler/spark arrester				◆	
Clean cooling system				◆	
Replace spark plug					◆
Check and adjust idle speed					◆
Check and adjust valve clearance					◆
Replace air filter					◆
Check and adjust impeller clearance					◆
Clean combustion chamber	Every 500 hours				
Clean fuel tank and filter	Every 1 year				
Check fuel tube	Every 2 years				

* After initial break-in, change the engine oil and filter. Oil change interval can then be extended to 100 hours.

DAILY MAINTENANCE CHECKS AND TIPS

- Check the engine oil level daily before starting engine.
- **DO NOT** start the pump if the oil level is low! The normal operating level for the engine oil is when oil is present on the crosshatch pattern of the dipstick. Add oil to the engine if it does not start or if oil is not present on the dipstick when tested.
- **DO NOT** overfill the crankcase.
- Consult the engine operator's manual for the proper grade of oil, including special operating conditions such as a change in season or climate.

ADDING ENGINE OIL

1. Place the pump on a firm, level surface.
2. Remove the oil fill cap/dipstick. Clean the area around the oil fill cap and wipe the dipstick clean.
3. Insert the dipstick in oil filler neck. Do not thread into filler neck. Remove the dipstick, and check the oil level.
4. If oil is needed, carefully add oil to the bottom of the oil filler neck, below the threads. While filling, stop to check oil level. DO NOT overfill.
5. Insert oil fill cap/dipstick and secure tightly.
6. Check engine oil level before each use of the pump.

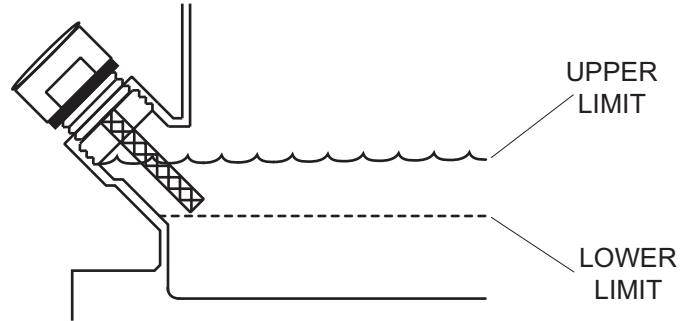

CLEANING THE PUMP

After running the pump in water containing dirt or debris, clean out the inside of pump housing.

1. Remove drain plug from pump housing. Drain any water left in the pump.
2. Remove the pump cover.
3. Clean out dirt and debris. Inspect impeller and volute for wear.

▲ WARNING

Impeller may develop sharp edges. Use caution when cleaning around impeller to avoid serious injury.

STORING THE PUMP

If the pump is to be stored for more than 4 weeks (30 days), please take the following actions in preparing the unit for storage.

▲ WARNING

Never open priming plug, discharge plug or cover when pump is hot, doing so may result in severe burns.

NOTICE

Always drain the pump casing if the ambient air temperature is expected to drop below 32°F (0°C).

1. After pump has cooled, remove drain plug from pump casing and drain out any remaining water.
2. Remove pump cover and clean inside of pump housing. Coat inside of pump with a light film of oil to reduce corrosion.
3. Tape up suction and discharge ports to prevent anything from falling into pump.
4. Change engine oil.
5. Cover pump and engine. Store in a clean, dry area.

UNIT ASSEMBLY AND PARTS

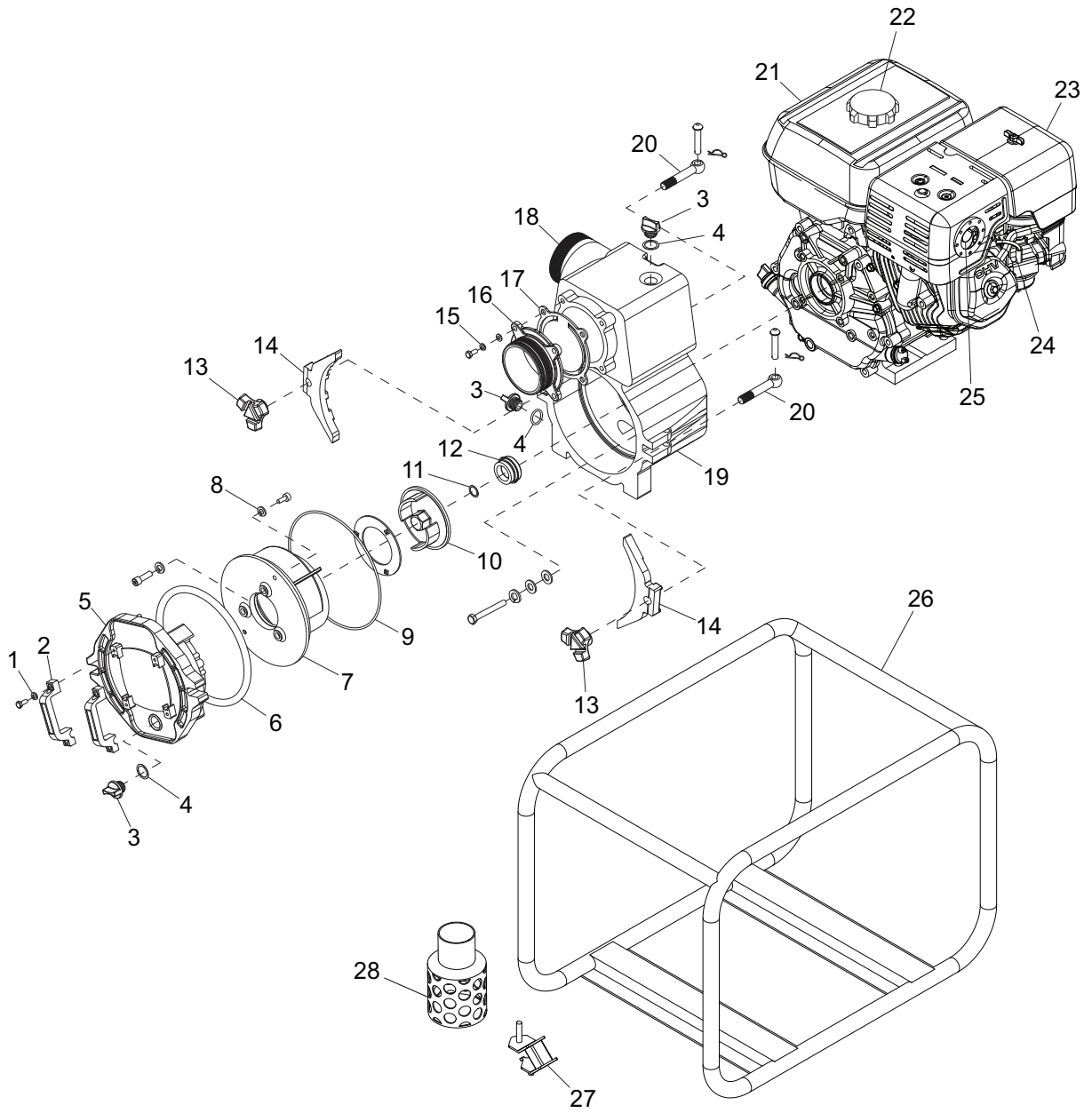

ITEM	PART	QTY	DESCRIPTION	NOTES
1	41761	4	Spring washer	
2	41753	2	Handles	
3	41736	3	Cap plug	
4	41762	3	O-ring, 24mm	
5	41730	1	Cover	
6	41766	1	O-ring, 242mm	
7	41723	1	Inner casing	
8	41760	3	Spring washer	
9	41767	1	O-ring, 220mm	
10	41729	1	Impeller	
11	41738	1	Copper plug	
12	41735	1	Mechanical seal	
13	41752	2	Screw nut	
14	41751	2	Press board	
15	41757	3	Spring washer	
16	41718	1	Suction flange	
17	41734	1	Check valve	
18	41719	1	Iron tube	
19	41655	1	Casing	
20	41755	2	Screw nut	
21	26614	1	Fuel tank	
22	26616	1	Fuel filler cap	
23	26654	1	Air filter	Located under cover
24	26605	1	Spark plug	
25	26620	1	Muffler	
26	41774	1	Roll cage	
27	41773	4	Rubber	
28	41772	1	Strainer	
-	26617	1	Fuel filter	Not shown
-	26606	1	Starter return spring	Not shown
-	26652	1	Carb gasket set	Not shown
-	26608	1	Recoil starter rope	Not shown
-	26655	1	Primary filter - outer	Not shown
-	26625	1	Gasket, muffler	Not shown

UNIT DECALS

PN: 26562
Decal, small "M" - portables



PUMP PUMP BEFORE STARTING.
Bomba primero antes de comenzar.
Pompe principale avant de commencer.

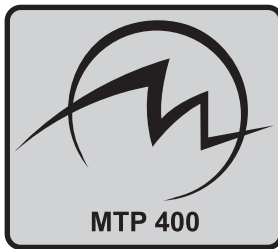

PN: 41948
Decal, MTP400

REV: A
PART NO: 41863
05.27.09