

Revised Starting Serial # 1470

## PARTS LIST MANUAL

# Model TG-10



### 10" Turbo Grinder



100 Thomas Johnson Drive, Frederick, MD 21702-4600 USA  
Phone (301) 663-1600 • 1-800-638-3326  
Fax (301) 663-1607 • 1-800-447-3326  
Website: [www.edcoinc.com](http://www.edcoinc.com) • Email: [sales@edcoinc.com](mailto:sales@edcoinc.com)

Printed in USA  
©2005

READ AND UNDERSTAND THE OPERATORS INSTRUCTION MANUAL THOROUGHLY BEFORE ATTEMPTING TO OPERATE THIS EQUIPMENT. Death or serious injury could occur if this machine is used improperly.



## SAFETY MESSAGES



The safety instructions are preceded by a graphic alert message of DANGER, WARNING, or CAUTION.



Indicates an imminent hazard which, if not avoided, will result in death or serious injury.



Indicates an imminent hazard which, if not avoided, can result in death or serious injury.



Indicates hazards which, if not avoided, could result in serious injury and or damage to the equipment.

## GASOLINE Powered Equipment



## ELECTRICAL Powered Equipment



- Do not operate gasoline powered equipment without adequate ventilation. Carbon monoxide is an invisible, odorless gas that can kill.
- **ELECTRICAL HAZARD** - Be sure equipment is properly grounded. Failure to comply could kill or result in serious injury.



The engine exhaust from this product contains chemicals known to the State of California to cause cancer, birth defects or other reproductive harm.

## GENERAL INSTRUCTIONS



- You must read and understand the operators instruction manual and all other manuals associated with this machine. For your safety and the safety of others around you, it is extremely important to fully understand how to operate this machine in the way it was intended. Different model machines or older/newer versions of the same model may have different parts and controls that you need to understand. If instructions are not readable or available DO NOT USE this machine and contact the factory for a replacement Manual.
- You must be able to physically handle the bulk weight and power of this machine. If not properly controlled this machine can cause death or serious injury.
- Do not operate this machine in an impaired mental state. You must be able to exercise good judgement and reactions to maintain a safe working environment.
- This is a "one person" machine which means only one operator can be operating the machine at any one time. For the safety of others, maintain a safe operating distance to other personnel. Your work area should be defined and appropriately marked so bystanders and coworkers do not stand or walk near this machine and end up seriously injured by flying debris or exposing them to harmful noise or dust.
- This equipment is for Commercial use. Although this is a "one person" machine your work team should understand how to shut this machine off and quickly get medical help if an accident strikes the operator.
- Keep all guards in place during operation. The guards are to provide protection from inadvertent contact with dangerous moving parts, pinch points, or hot surfaces.
- Wear appropriate Personal Protective Equipment (PPE) including safety glasses, safety boots, work gloves, respiratory protection, hearing protection, and head protection. Do not wear loose clothing that can get tangled in moving parts. Failure to do so could result in dismemberment or death. **Wear an approved respirator when removing hazardous materials or when grinding/cutting dry materials. Some dust particles such as concrete dust can contain silicate particles which can cause silicosis (a very serious lung disease). Contact NIOSH or OSHA for further details. When wet grinding/cutting, avoid contact with the concrete/asphalt slurry which can cause serious skin irritations.**
- You must maintain this machine per the maintenance schedule in the operator manual. Remember before adjusting, servicing, or fueling this machine, disconnect the source of power to the machine by disconnecting the spark plug (Gas models), or by unplugging the electrical power cord (electric models) or air hose (Pneumatic models) AT THE MACHINE so you can assure yourself it remains unplugged while you are working on it. Do not modify this machine. Use only genuine EDCO parts and accessories. Repairs and service should be performed by approved EDCO dealers or authorized technicians.
- You should look carefully around the area before you begin work so you can identify potential hazards such as deck inserts, pipes, columns, openings, electrical cords or outlets, or any other objects protruding from the slab surface.
- This machine has no brain so you must use your own. There is no substitute for safety. The safety decals on the machine are to serve as a reminder for information you must already know before you begin using this machine. Take a moment to reread the safety decals each time you use the machine. If your machine is missing any decals, contact the factory for a replacement (EDCO 1-800-638-3326).

# PARTS LIST MANUAL

## EDCO MODEL TG-10

| Section   | Page Number |
|---|-------------|
| Safety Messages and General Instructions .....                                    | 2           |
| How To Order Replacement Parts .....  | 3           |
| Illustration 1: Main Assembly Grouping .....                                      | 4           |
| Parts Listing - Illustration 1 : Main Assembly Grouping .....                     | 5           |
| Illustration 2: Rigid Head Assembly .....   | 6           |
| Parts Listing - Illustration 2: Rigid Head Assembly .....                         | 6           |
| Illustration 3: Flex Head Assembly .....  | 7           |
| Parts Listing - Illustration 3 : Flex Head Assembly .....                         | 7           |
| Illustration 4: Engine Grouping .....   | 8           |
| Parts Listing - Illustration 4 : Engine Grouping .....                            | 9           |
| Illustration 5: Propane Grouping .....  | 10          |
| Parts Listing - Illustration 5 : Propane Grouping .....                           | 11          |
| Illustration 6: Motor Grouping .....  | 12          |
| Parts Listing - Illustration 6 : Motor Grouping .....                             | 13          |
| Illustration 7: Optional Ball Caster Depth Stop Kit & Weight .....                | 14          |
| Parts Listing - Illustration 7 : Optional Ball Caster Depth Stop Kit & Weight ... | 15          |
| Limited Equipment Warranty .....  | back cover  |

### 10" TURBO GRINDERS

| *PART #   | MODEL         | POWER OPTION                  |
|-----------|---------------|-------------------------------|
| 56600     | TG10-11H      | 11HP HONDA GASOLINE           |
| 56700     | TG10-11P      | 11HP HONDA PROPANE            |
| 56800-230 | TG10-5B/230/3 | 5HP BALDOR, 230 VOLT, 3 PHASE |
| 56800-460 | TG10-5B/460/3 | 5HP BALDOR, 460 VOLT, 3 PHASE |
| 56900     | TG10-5B/230/1 | 5HP BALDOR, 230 VOLT, 1 PHASE |

**\* ADD -F SUFFIX TO PART # FOR TURBO GRINDER w/ FLEXIBLE STYLE HEAD**

#### HOW TO ORDER REPLACEMENT PARTS

- To insure product safety and reliability, always use genuine EDCO replacement parts when making repairs to the equipment.
- When calling for parts, specify the MODEL and SERIAL NUMBER of the machine which can be found on the NAME PLATE. Keep that information in the space provided. In addition to this information, give part number, description and quantity as listed on the parts list to your parts representative.
- Please note: Due to improvements and changes in the equipment, the illustrations shown

#### FILL IN INFORMATION BELOW

Date of Purchase \_\_\_\_\_  
 Name of Machine \_\_\_\_\_  
 Model # \_\_\_\_\_  
 Serial # \_\_\_\_\_  
 Belt Size(s) \_\_\_\_\_

Toll Free: 1-800-638-3326  
 FAX: 1-800-447-3326  
 email: sales@edcoinc.com  
 www.edcoinc.com



100 Thomas Johnson Drive, Frederick, MD 21702-4600 USA  
 Phone (301) 663-1600 • 1-800-638-3326  
 Fax (301) 663-1607 • 1-800-447-3326  
 Website: www.edcoinc.com • Email: sales@edcoinc.com

Printed in USA  
 ©2005



## PARTS LISTING - ILLUSTRATION 1: MAIN ASSEMBLY GROUPING

| ITEM# | PART# | DESCRIPTION                                       | QTY. | ITEM# | PART#   | DESCRIPTION   | QTY. |
|-------|-------|---|------|-------|---------|---|------|
| 1     | 86336 | MAIN FRAME  | 1    | 24    | 10657   | BARB. PUSH-ON 3/8 HOSE x 1/4 MPT  | 1    |
| 2     | 10321 | SCREW, CAP 1/2-20 x 1-1/4                         | 4    | 25    | 11562   | BARB, ELBOW 90°, 3/8 HOSE x 1/8 MPT   | 1    |
| 3     | 10045 | WASHER, LOCK 1/2                                  | 4    | 26    | 10864   | NUT 1/8-27 PIPE THREAD  | 1    |
| 4     | 86303 | HOOD  | 1    | 27    | 19166   | 10" DIAMOND DISC -MULTI-PURPOSE (REFER TO ACCESSORY PRICE LIST FOR OTHER STYLE DISCS) | 1    |
| 5     | 10907 | SCREW, CAP 3/8-16 x 3/4                           | 2    | 28    | 86108   | SCREW, FLAT HEAD SKT. 3/8-24 x 3/4  | 4    |
| 6     | 10811 | WASHER, LOCK 3/8                                  | 2    | 29    | 86320A  | HUB ASSEMBLY w/ BRGS. & SEALS (ITEMS 30-33)   | 1    |
| 7     | 10025 | WASHER, FLAT 3/8                                  | 2    | 30    | 86320HG | HUB ONLY w/ RACES & GREASE FITTING HOLE   | 1    |
| 8     | 86338 | CLAMP, HOSE , SAE #188, 12-1/4                    | 1    | 31    | 10808   | FITTING, GREASE 1/4-28 STRAIGHT   | 1    |
| 9     | 86337 | RUBBER, SKIRT 2" H x 35 1/8" L                    | 1    | 32    | 86321   | BEARING, TAPERED ROLLER 1" ID CONE  | 2    |
| 10    | 86345 | WEIGHT BLOCK, 30 LB. (ELEC. ONLY)                 | 1    | 33    | 86322   | SEAL, BEARING HUB 1-1/4   | 2    |
| 11    | 10323 | SCREW, CAP 1/2-13 x 2-1/2 (ELEC. ONLY)            | 2    | 34    | 86319   | SPACER, HUB BEARING   | 2    |
| 12    | 10045 | WASHER, LOCK 1/2 (ELEC. ONLY)                     | 2    | 35    | 50019   | NUT, JAM 1-14   | 2    |
| 13    | 86328 | HOSE, FLEXIBLE, 2" ID x 34-1/2                    | 1    | 36    | 86323   | WASHER, NORD-LOCK 1" (PAIR)   | 1    |
| 14    | 10745 | CLAMP, HOSE, SAE #32, ADJ. TO 2-1/4"              | 2    | 37    |         | HEAD ASSEMBLY (SEE ILLUSTRATION #2 & 3)   | 1    |
| 15    | 65021 | PLUG, CAP 2"                                      | 1    | 38    | 86304   | HANDLE BAR  | 1    |
| 16    | 86307 | VAC. PORT BRACKET, 2"                             | 1    | 39    | 10608   | GRIP, HAND 1" MODEL AT  | 2    |
| 17    | 10877 | SCREW, CAP STSHW 10-24 x 1/2                      | 2    | 40    | 10029   | SCREW, CAP 3/8-24 x 1-3/4   | 4    |
| 18    | 10831 | WASHER, LOCK, INT. TOOTH #10                      | 2    | 41    | 10025   | WASHER, FLAT 3/8  | 8    |
| 19    | 10711 | VALVE, BALL 1/2 FPT                               | 1    | 42    | 10004   | NUT, LOCK 3/8-24  | 4    |
| 20    | 80021 | CONN., SWIVEL FEM. 3/4 HOSE x 1/2 MPT (INCL. #21) | 1    | 43    | 79013   | WHEEL 8 x 2-1/2 x 3/4" BRG.   | 2    |
| 21    | 10070 | WASHER, HOSE (INCL. w/ #20)                       | 1    | 44    | 10428   | COLLAR, LOCKING 3/4" ID   | 2    |
| 22    | 86329 | HOSE 3/8 ID x 19-1/4                              | 1    | 45    | 10009   | WASHER, FLAT 3/4  | 4    |
| 23    | 50069 | CLAMP, HOSE, SAE #6, ADJ. TO 13/16                | 2    | 46    |         | HEAD ASSY. w/ BRG. (ITEMS 29-37)  | 1    |
|       |       |   |      |       | 86333   | RIGID STYLE   |      |
|       |       |   |      |       | 86326   | FLEXIBLE STYLE  |      |



100 Thomas Johnson Drive, Frederick, MD 21702-4600 USA  
 Phone (301) 663-1600 • 1-800-638-3326  
 Fax (301) 663-1607 • 1-800-447-3326  
 Website: www.edcoinc.com • Email: sales@edcoinc.com

Printed in USA  
 ©2005

**ILLUSTRATION 2: RIGID HEAD ASSEMBLY**

**STANDARD**

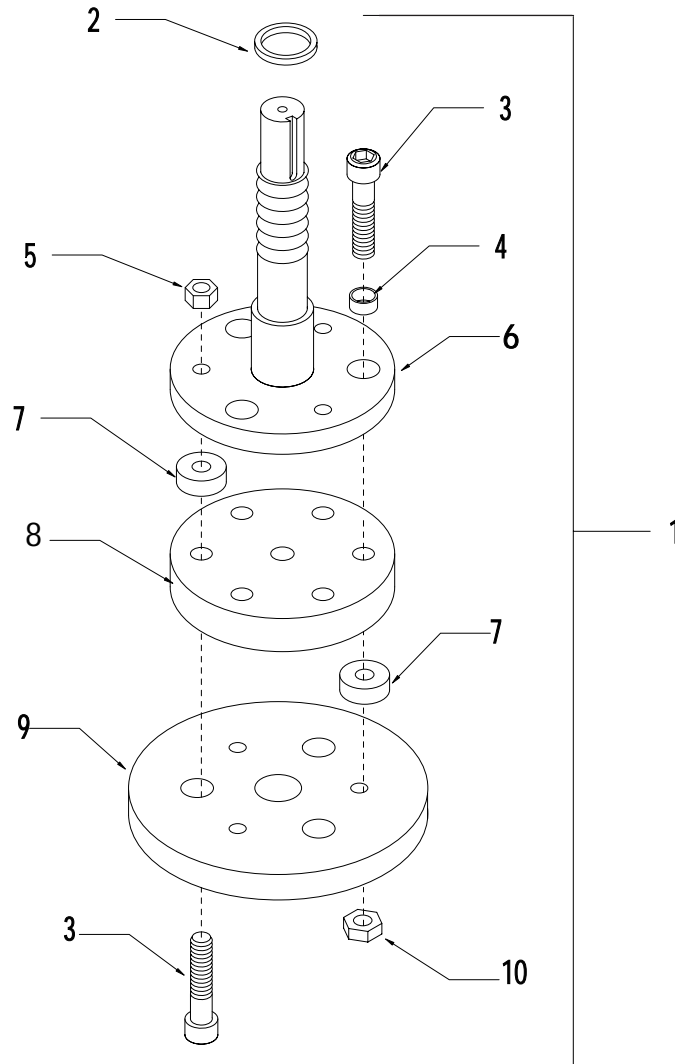

| ITEM # | PART #  | DESCRIPTION   | QTY. |
|--------|---------|---|------|
| 1      | 86333LB | HEAD ASSY. LESS BRG., RIGID (INCLUDES ITEMS # 2-10) | 1    |
| 2      | 68017   | SPACER STEEL, 1-1/4" OD x 1" ID x 5/32" THK.        | 1    |
| 3      | 86111   | SCREW, SKT. HD. CAP 7/16-20 x 2 (GRD. 8)            | 6    |
| 4      | 86112   | SPACER, STEEL 5/8" OD x 7/16" ID x 1/4" THK.        | 3    |
| 5      | 10481   | NUT, 7/16-20 (NOTE: USE RED LOCTITE)                | 3    |
| 6      | 86334   | FLANGE w/ SHAFT, RIGID HEAD                         | 1    |
| 7      | 40329   | BUSHING, RUBBER 1" OD x 3/8" ID x 3/8" THK.         | 6    |
| 8      | 86132S  | SPACER, DIAMOND HEAD, STEEL                         | 1    |
| 9      | 86133   | DIAMOND HEAD MOUNTING DISC, RIGID HEAD              | 1    |
| 10     | 11641   | NUT, JAM 7/16-20                                    | 3    |

### ILLUSTRATION 3: FLEX HEAD ASSEMBLY

OPTIONAL

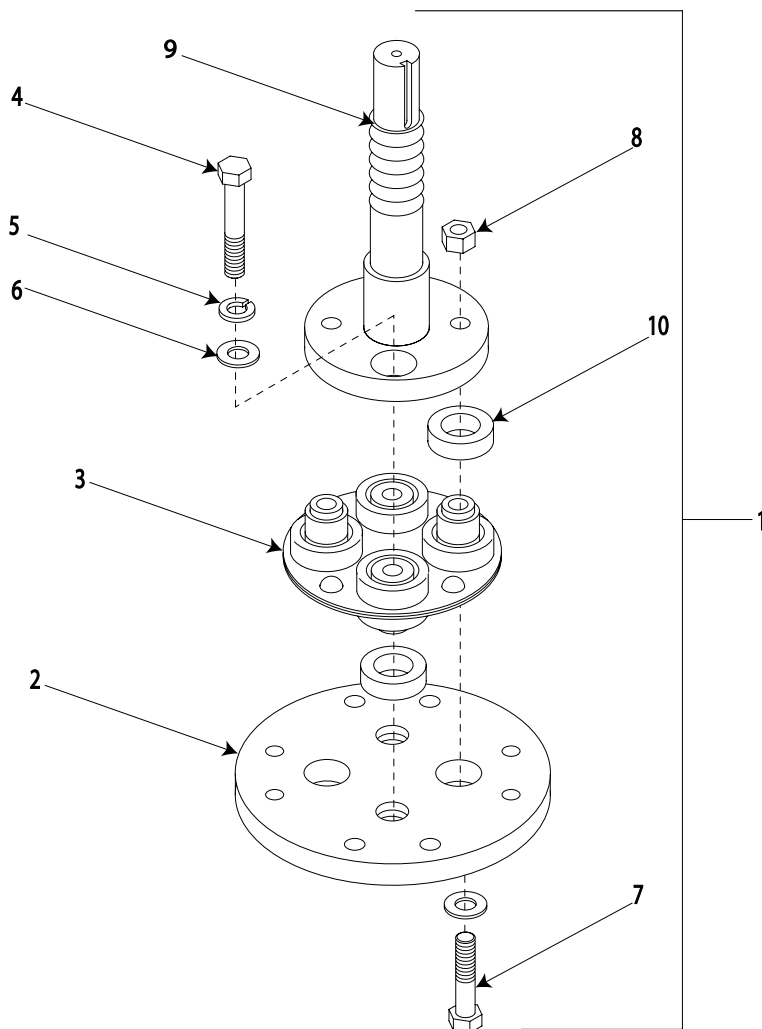

| ITEM # | PART #  | DESCRIPTION  | QTY. |
|--------|---------|--|------|
| 1      | 86326LB | HEAD ASSY. LESS BRG., FLEX (INCLUDES ITEMS # 2-10) |      |
| 2      | 86309   | MOUNTING DISC, FLEX HEAD                           | 1    |
| 3      | 86017   | COUPLING, MORFLEX 402                              | 1    |
| 4      | 10030   | SCREW, CAP 3/8-24 x 2 ( USE RED LOCTITE)           | 2    |
| 5      | 10811   | WASHER, LOCK 3/8                                   | 2    |
| 6      | 10025   | WASHER, FLAT 3/8                                   | 4    |
| 7      | 10336   | SCREW, CAP 3/8-24 x 2-1/4                          | 2    |
| 8      | 10004   | NUT, LOCK 3/8-24                                   | 2    |
| 9      | 86308   | FLANGE w/ SHAFT, FLEX HEAD                         | 1    |
| 10     | 86343   | BUSHING, RUBBER 1-1/4 x 3/4 x 3/8                  | 4    |



100 Thomas Johnson Drive, Frederick, MD 21702-4600 USA  
 Phone (301) 663-1600 • 1-800-638-3326  
 Fax (301) 663-1607 • 1-800-447-3326  
 Website: www.edcoinc.com • Email: sales@edcoinc.com

Printed in USA  
 ©2005

# ILLUSTRATION 4 : ENGINE GROUPING

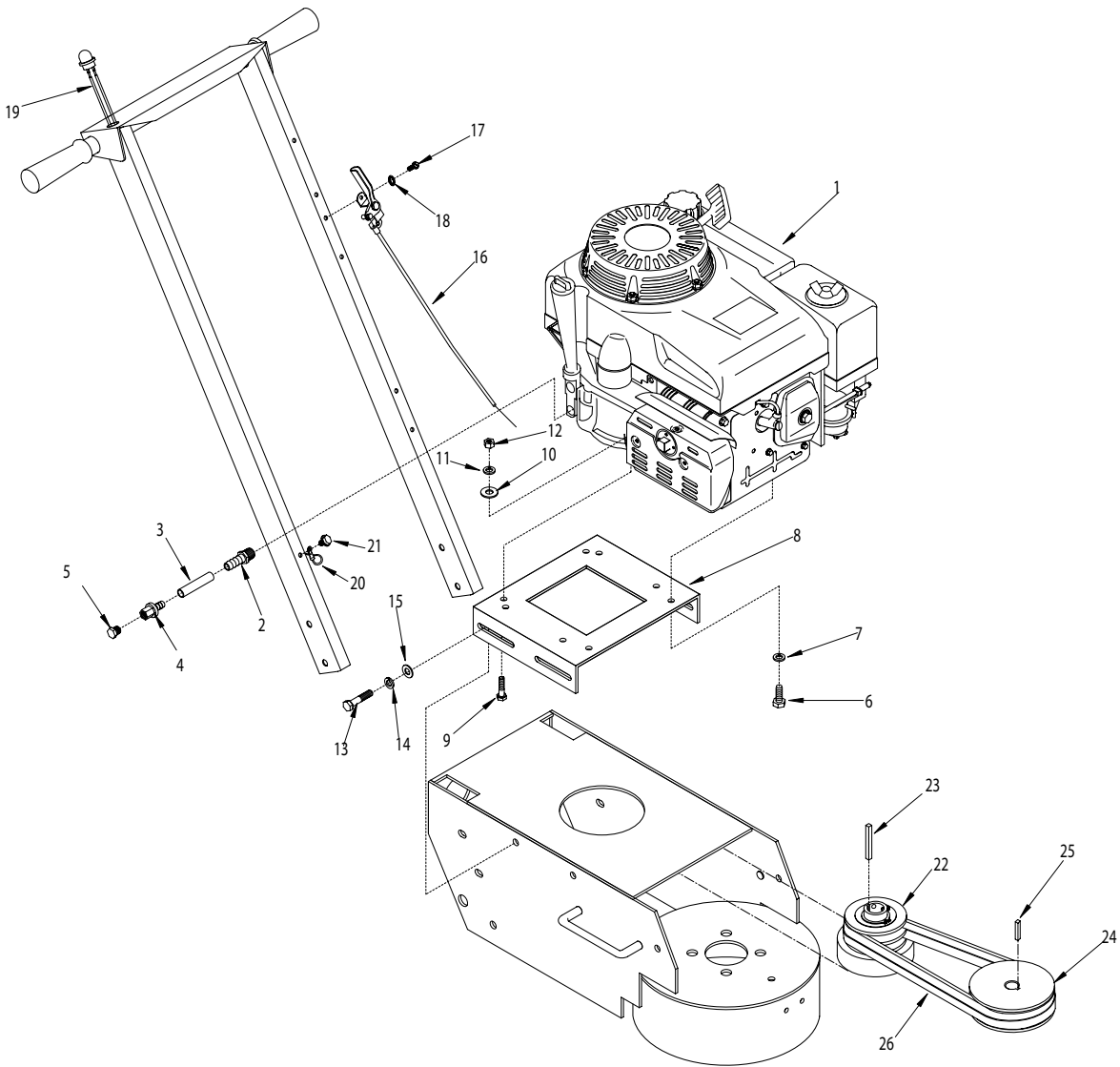

| <b>PARTS LISTING - ILLUSTRATION 4 : ENGINE GROUPING</b> |        |  |      |
|---|--------|--|------|
| ITEM #  | PART # | DESCRIPTION                                | QTY. |
| 1   | 76004  | ENGINE, HONDA 11HP GXV340 K2-DX3           | 1    |
| 2   | 11543  | BARB, PUSH-ON 3/8 HOSE x 20mm x 1.50       | 1    |
| 3   | 56116  | HOSE, PUSH-ON 3/8 ID x 3"L                 | 1    |
| 4   | 11544  | BARB, PUSH-ON 3/8 HOSE x 1/4 FPT           | 1    |
| 5   | 10776  | PIPE PLUG 1/4 NPT (BRASS)                  | 1    |
| 6   | 10048  | SCREW, CAP 5/16-24 x 3/4                   | 2    |
| 7   | 10801  | WASHER, LOCK 5/16                          | 2    |
| 8   | 86311  | MOUNT, ENGINE/MOTOR                        | 1    |
| 9   | 10342  | SCREW,CAP 5/16-18 x 1-1/2                  | 2    |
| 10  | 10213  | WASHER, FLAT 5/16                          | 2    |
| 11  | 10801  | WASHER, LOCK 5/16                          | 2    |
| 12  | 10054  | NUT 5/16-18                                | 2    |
| 13  | 10021  | SCREW, CAP 3/8-24 x 1                      | 4    |
| 14  | 10811  | WASHER, LOCK 3/8                           | 4    |
| 15  | 10025  | WASHER, FLAT 3/8                           | 4    |
| 16  | 40388  | THROTTLE CABLE, LEVER-TYPE, 24" (TRIM 17") | 1    |
| 17  | 10877  | SCREW, CAP STSHW 10-24 x 1/2               | 2    |
| 18  | 10831  | WASHER, LOCK, INT. TOOTH # 10              | 1    |
| 19  | 50010  | SWITCH KIT, STOP BUTTON, 7/8" HOLE         | 1    |
| 20  | 50084  | TERM. RING #10, 16-14 GA. INSULATED        | 1    |
| 21  | 10877  | SCREW, CAP STSHW 10-24 x 1/2               | 1    |
| 22  | 76024  | CLUTCH, CENTRIFUGAL 3.5 x 2GR. x 1         | 1    |
| 23  | 10071  | KEY 1/4 SQ. x 2-1/2                        | 1    |
| 24  | 86318  | SHEAVE 5"OD x 2GR.B x 7/8 BORE             | 1    |
| 25  | 50523  | KEY 3/16 SQ. x 1-1/8                       | 1    |
| 26  | 10035  | BELT 5L-330 (REFER TO SERIAL NO. PLATE)    | 2    |



# ILLUSTRATION 5 : PROPANE GROUPING

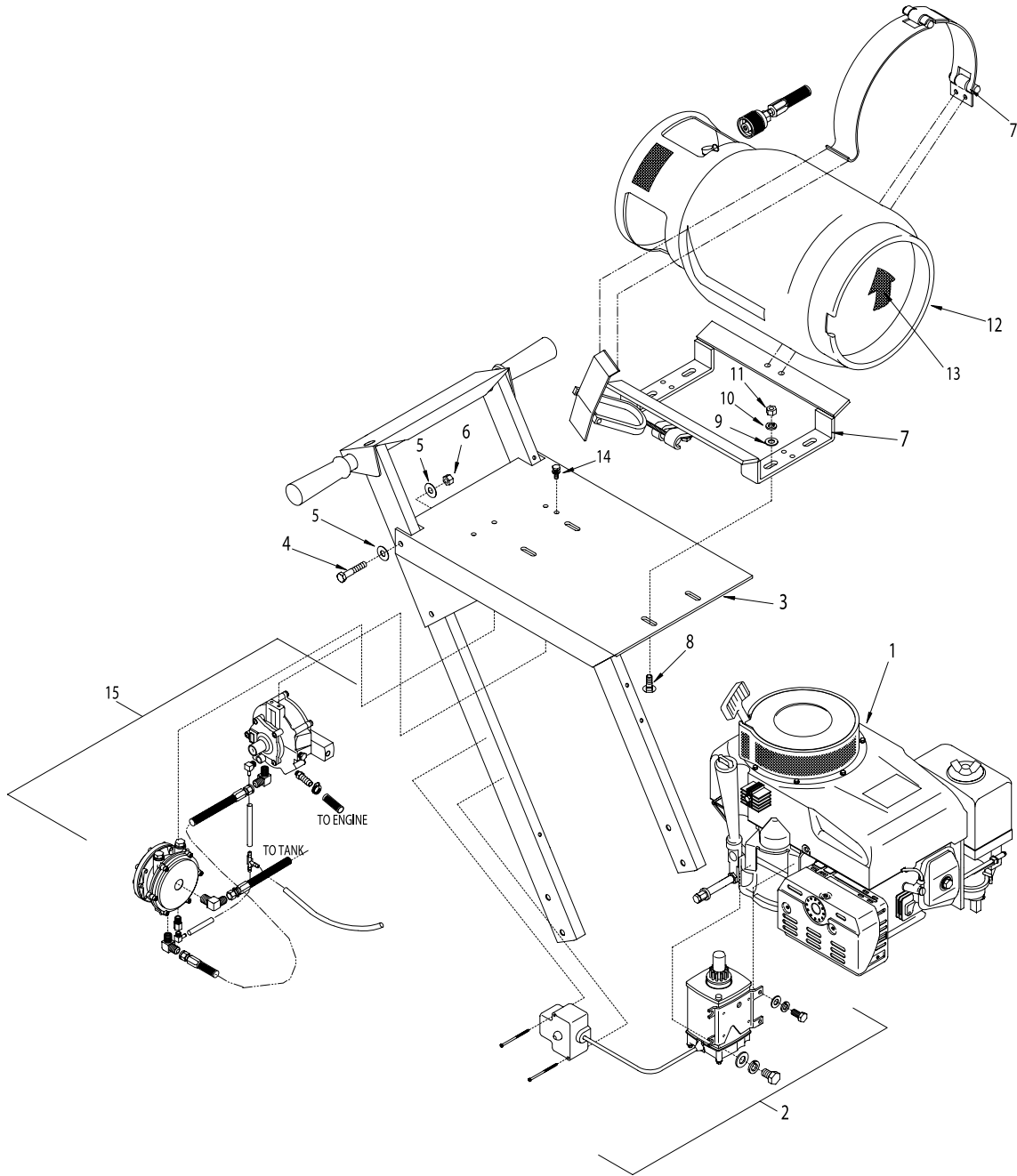

### PARTS LISTING - ILLUSTRATION 5 : PROPANE GROUPING

| ITEM # | PART # | DESCRIPTION   | QTY. |
|--------|--------|---|------|
| 1      | 15012  | ENGINE, HONDA 11HP GXV-340A2-DP23 PROPANE                                   | 1    |
| 2      | 15126  | STARTER KIT, ELECTRIC 120 VOLT AC<br>( INCLUDES EXTENSION CORD - NOT SHOWN) | 1    |
| 3      | 86327  | MOUNT, PROPANE TANK, TG-10  | 1    |
| 4      | 10029  | SCREW, CAP 3/8-24 x 1-3/4   | 4    |
| 5      | 10025  | WASHER, FLAT 3/8  | 8    |
| 6      | 10004  | NUT, LOCK 3/8-24  | 4    |
| 7      | 77061  | PROPANE TANK MOUNT COMPLETE   | 1    |
| 8      | 10802  | BOLT, CARRIAGE 3/8-16 x 1   | 4    |
| 9      | 10025  | WASHER, FLAT 3/8  | 4    |
| 10     | 10811  | WASHER, LOCK 3/8  | 4    |
| 11     | 10404  | NUT 3/8-16  | 4    |
| 12     | 15130  | PROPANE TANK 20LB HORZ. w/ ACME VALVE                                       | 1    |
| 13     | 91122  | DECAL, ARROW, RED, 3 x 3  | 1    |
| 14     |        | SCREW w/ WASHER, CAP 1/4-20 x 5/8<br>(C/W VAPOR KIT)                        | 4    |
| 15     | 15102  | VAPOR KIT for HONDA GXV340A2-DP23   | 1    |



# ILLUSTRATION 6 : ELECTRIC MOTOR GROUPING

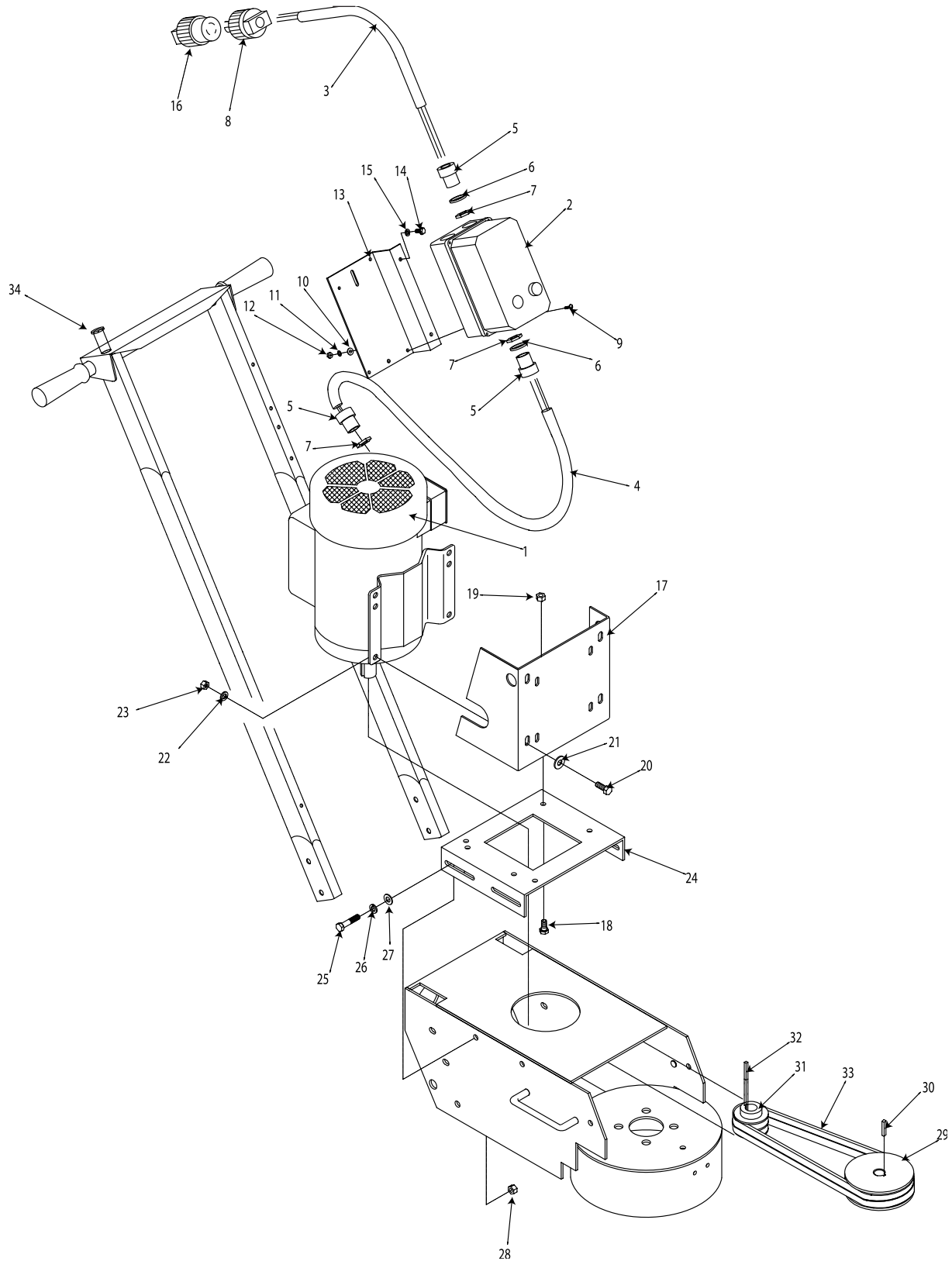

| <b>PARTS LISTING - ILLUSTRATION 6 : ELECTRIC MOTOR GROUPING</b> |               |  |             |
|---|---------------|--|-------------|
| <b>ITEM #</b>   | <b>PART #</b> | <b>DESCRIPTION</b>                             | <b>QTY.</b> |
| 1   |               | MOTOR, BALDOR                                  | 1           |
|   | 81026         | 5.0 HP - 1 PHASE - 60 Hz - 230V 3450 RPM       |             |
|   | 81022         | 5.0 HP - 3 PHASE - 60Hz - 230V/460V 3450 RPM   |             |
| 2   |               | STARTER, LOVATO                                | 1           |
|   | 16410         | 1 PH - 60Hz - 230V (11-M1-BRF-P30-26-23060)    |             |
|   | 16405         | 3 PH - 60Hz - 230V (11-M1-BRF-P23-23-23060)    |             |
|   | 16406         | 3 PH - 60Hz - 460V (11-M1-BRF-P14-10-46060)    |             |
| 3   |               | WIRE HARNESS, STARTER / PLUG                   | 1           |
|   | 86026         | 10/3" x 24" LOA ( 1 PHASE UNITS )              |             |
|   | 86022         | 12/4" x 24" LOA (3 PHASE UNITS)                |             |
| 4   |               | WIRE HARNESS, STARTER / MOTOR                  | 1           |
|   | 86331         | 10/3" x 36" LOA ( 1 PHASE UNITS )              |             |
|   | 86332         | 12/4" x 36" LOA (3 PHASE UNITS)                |             |
| 5   | 10605         | CONNECTOR, STRAIN RELIEF 3/4 NPT x .650 - .750 | 3           |
| 6   | 77081         | WASHER, FLAT 1-9/16 x 1-1/16 x .06             | 2           |
| 7   | 10740         | CONDUIT LOCK NUT 3/4 NP                        | 3           |
| 8   | 40037         | PLUG, LOCKING 20A/250V (SEE NOTE)              | 1           |
| 9   | 10362         | SCREW, MACHINE 8-32 x 3/4                      | 4           |
| 10  | 12112         | WASHER, RIVET #9 5/32 x 7/16 x 3/64            | 4           |
| 11  | 10461         | WASHER, LOCK, INT. TOOTH #8                    | 4           |
| 12  | 10462         | NUT 8-32                                       | 4           |
| 13  | 86027         | MOUNTING BRACKET, LOVATO STARTER               | 1           |
| 14  | 10846         | SCREW, CAP STSHW 1/4-20 x 1/2                  | 2           |
| 15  | 10038         | WASHER, LOCK 1/4                               | 2           |
| 16  | 40000         | PLUG CONNECTOR, LOCKING 20A/250V (SEE NOTE)    | 1           |
| 17  | 86312         | MOUNT, MOTOR                                   | 1           |
| 18  | 10907         | SCREW, CAP 3/8-16 x 3/4                        | 4           |
| 19  | 10810         | NUT, LOCK 3/8-16                               | 4           |
| 20  | 10021         | SCREW, CAP 3/8-24 x 1                          | 4           |
| 21  | 10025         | WASHER, FLAT 3/8                               | 4           |
| 22  | 10811         | WASHER, LOCK 3/8                               | 4           |
| 23  | 10014         | NUT 3/8-24                                     | 4           |
| 24  | 86311         | ENGINE/MOTOR MOUNT                             | 1           |
| 25  | 10021         | SCREW, CAP 3/8-24 x 1                          | 4           |
| 26  | 10811         | WASHER, LOCK 3/8                               | 4           |
| 27  | 10025         | WASHER, FLAT 3/8                               | 4           |
| 28  | 10014         | NUT 3/8-24                                     | 4           |
| 29  | 86344         | SHEAVE 4.55" OD x 2Gr.B x 7/8 BORE             | 1           |
| 30  | 50523         | KEY 3/16" SQ. x 1-1/8                          | 1           |
| 31  | 79023         | SHEAVE 3" OD x 2 Gr.B x 1-1/8" BORE            | 1           |
| 32  | 10115         | KEY 1/4" SQ. x 2                               | 1           |
| 33  | 10035         | BELT 5L - 330 (REFER TO SERIAL NO. PLATE)      | 2           |
| 34  | 10005         | PLUG, HOLE 7/8" (CHROME )                      | 1           |

NOTE: PLUG & CONNECTOR (ITEMS # 8 & 16) ARE NOT SUPPLIED ON 3 PHASE UNITS.



**ILLUSTRATION 7: OPTIONAL BALL CASTER DEPTH STOP KIT & WEIGHT**

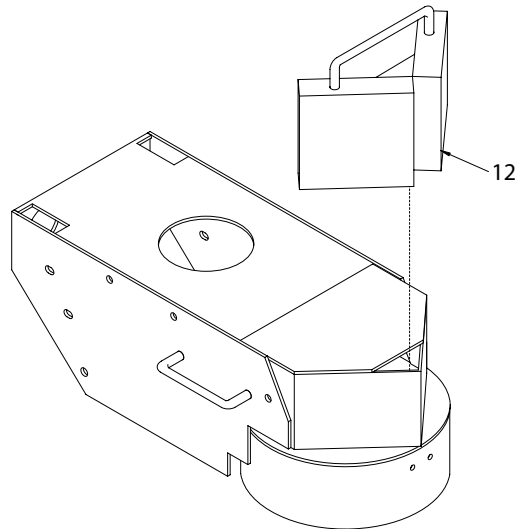
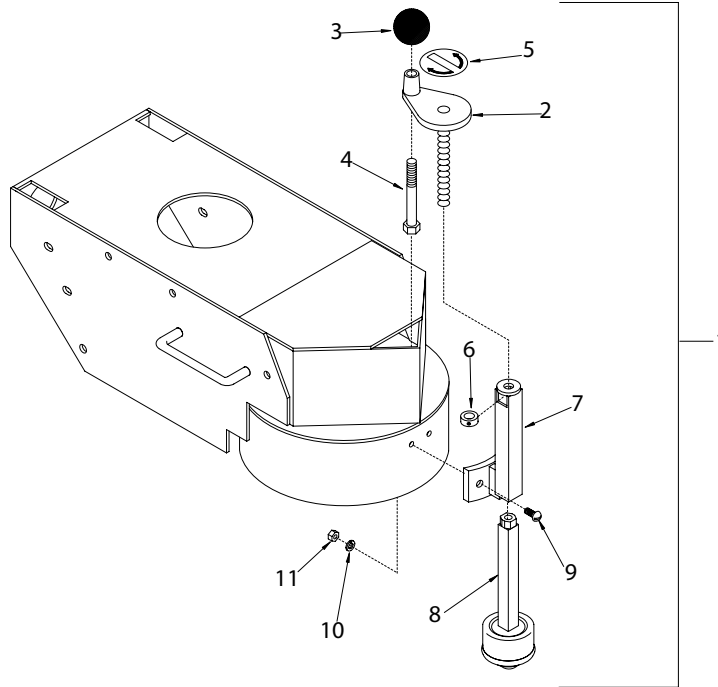

**PARTS LISTING - ILLUSTRATION 7: OPTIONAL BALL CASTER DEPTH STOP KIT & WEIGHT**

| ITEM# | PART# | DESCRIPTION  | QTY. |
|-------|-------|--|------|
| 1     | 86330 | BALL CASTER DEPTH STOP KIT (INCLUDES ITEMS # 2-11) |      |
| 2     | 86313 | HANDWHEEL, SMALL w/ ROD                            | 1    |
| 3     | 10104 | KNOB, BALL 1-7/8 DIA. w/ 1/2-13 THD., BLK.         | 1    |
| 4     | 81001 | SCREW, CAP 1/2-13 x 4                              | 1    |
| 5     | 80007 | DECAL, DEPTH STOP, DN/UP (SMALL)                   | 1    |
| 6     | 86316 | COLLAR, LOCKING 1/2"                               | 1    |
| 7     | 86314 | SUPPORT, DEPTH STOP                                | 1    |
| 8     | 86315 | BALL - CASTER WELDMENT                             | 1    |
| 9     | 10818 | BOLT, CARRIAGE 5/16-18 x 3/4                       | 2    |
| 10    | 10801 | WASHER, LOCK 5/16                                  | 2    |
| 11    | 10054 | NUT 5/16-18  | 2    |
| 12    | 86340 | WEIGHT, 30 LB.                                     | 1    |



# LIMITED EQUIPMENT WARRANTY

Equipment Development Company, Inc. herein referred to as EDCO warrants that each new unit manufactured by EDCO to be free from defects in material and workmanship in normal use and service for a period of (1) one year (except in the case of the cutter drum assembly on all model concrete asphalt planes, in which case the warranty period shall be 90 days) from date of shipment to the original retail or equipment rental center owner.

EDCO will, at its option, repair or replace, at the EDCO factory or at a point designated by EDCO any part, which shall appear to the satisfaction of EDCO inspection to have been defective in material or workmanship.

This warranty, does not apply to failure occurring as a result of abuse, misuse, negligent repairs, corrosion, erosion, normal wear and tear, alterations or modifications made to the product without express written consent of EDCO: or failure to follow the recommended operating practices and maintenance procedures as provided in the products operating and maintenance manuals.

This warranty does not obligate EDCO to bear any transportation charges in connection with the replacement or repair of defective parts. This warranty does not obligate EDCO to bear any expense for travel time or of personnel in connection with any service calls.

Accessories or equipment furnished and installed on the product by EDCO but manufactured by others, including but not limited to engines, motors, electrical equipment, transmissions, etc., shall carry the accessory manufacturers' own warranty.

THIS WARRANTY IS IN LIEU OF ALL OTHER WARRANTIES, EXPRESSED OR IMPLIED, OR STATUTORY, INCLUDING ANY WARRANTIES OF MERCHANTABILITY OR OF FITNESS FOR A PARTICULAR PURPOSE.

## LIABILITY LIMITATIONS

The remedies of the user set forth under provisions of warranty outlined above are the exclusive and total liability of EDCO with the respect to their sale or the equipment and service furnished hereunder, in connection with the performance or breach thereof, or from the sale, delivery, installation, repair or technical direction covered by or furnished under the sale, whether based on contract, warranty, negligence, indemnity, strict liability, or otherwise shall not exceed the purchase price of the unit of equipment upon which such liability is based.

EDCO will not in any event be liable to the user, any successors in interest or any beneficiary or assignee relating to this sale for any consequential, incidental, indirect, special or punitive damages arising out of this sale or any breach thereof, or any defects on, or failure of, or malfunction of the equipment under this sale based upon loss of use, lost profits or revenue, interest, lost goodwill, work stoppage, impairment of other goods, loss by reason of shutdown or non-operation, increased expenses of operation of the equipment, cost of purchase or replacement power of claims of users or customers of the user for service interruption whether or not such loss or damage is based on contract, warranty, negligence, indemnity, strict liability, or otherwise.

EDCO reserves the right to modify, alter and improve any part or parts without incurring any obligation to replace any part or parts previously sold without such modified, altered or improved part or parts.

No person is authorized to give any other warranty or to assume any additional obligation on EDCO's behalf unless made in writing and signed by an officer of EDCO.

Equipment Development Company, Inc.

## USE ONLY GENUINE EDCO PARTS AND ACCESSORIES

For your own safety, the safety of others and the life of your machine



# MANUAL CHOKE KIT

FOR HONDA GXV340 11 HP PART #15190

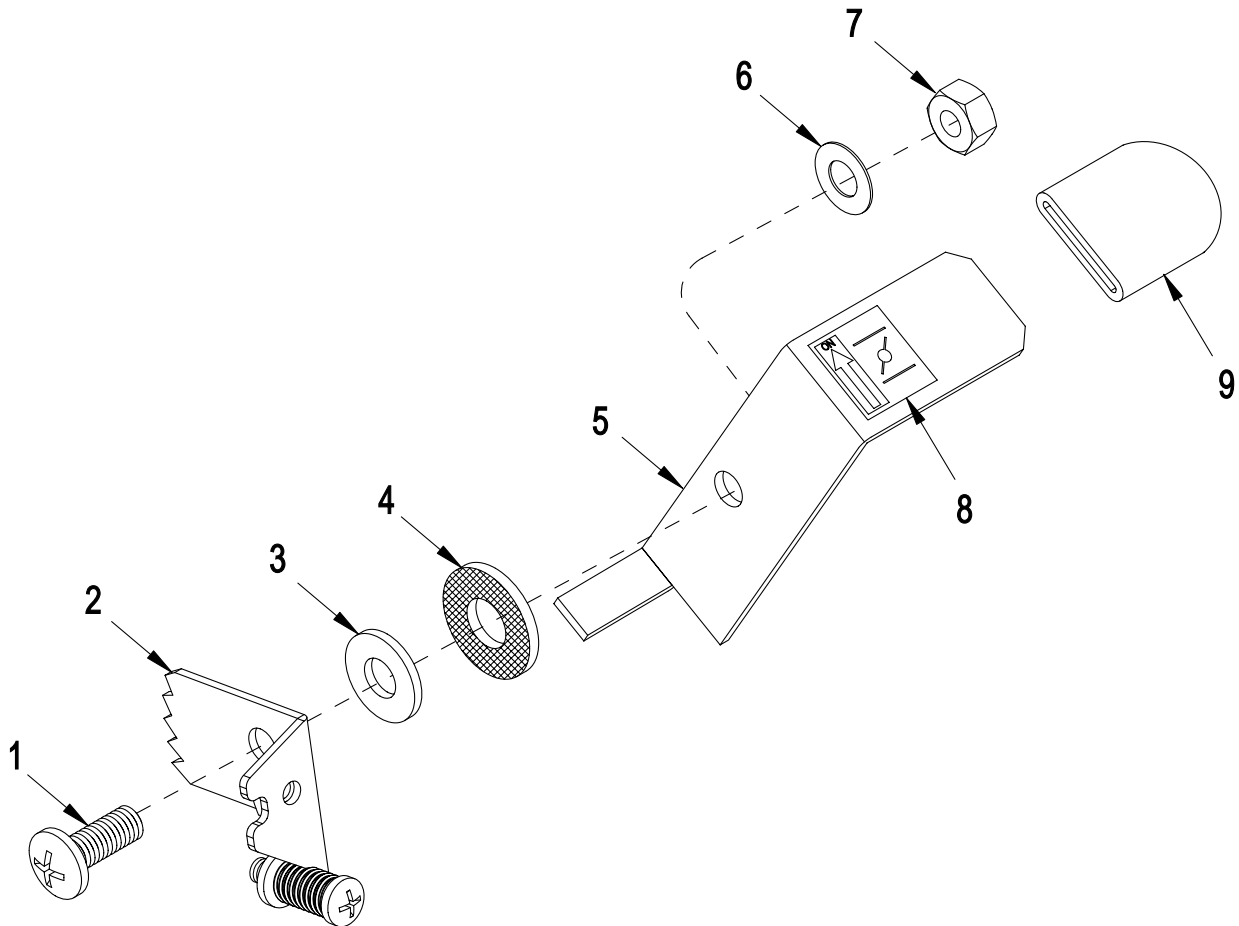

| ITEM# | PART# | DESCRIPTION   | QTY. |
|-------|-------|---|------|
| 1     | 15185 | SCREW, MACHINE M6 X 16MM PHILLIP HD                                   | 1    |
| 2     | ----- | BREAKAWAY VIEW OF ENGINE THROTTLE BRACKET (SHOWN FOR MOUNTING DETAIL) | -    |
| 3     | 10602 | WASHER, FLAT 1/4 SAE  | 1    |
| 4     | 15187 | WASHER, FIBER .75 X .25 X .093  | 1    |
| 5     | 15183 | LEVER, CHOKE CONTROL  | 1    |
| 6     | 15186 | WASHER, BELLEVILLE .500 X .255 X .018                                 | 1    |
| 7     | 28026 | NUT, HEX NYLON LOCK M6 X 1MM  | 1    |
| 8     | 91301 | DECAL, CHOKE 5/8 X 5/8  | 1    |
| 9     | 15184 | CAP, FLAT RED .062 X .75 X 1  | 1    |



100 Thomas Johnson Drive, Frederick, MD 21702-4600 USA  
 Phone (301) 663-1600 • 1-800-638-3326  
 Fax (301) 663-1607 • 1-800-447-3326  
 Website: [www.edcoinc.com](http://www.edcoinc.com) • Email: [sales@edcoinc.com](mailto:sales@edcoinc.com)

Printed in USA  
 ©2005