

Light Tower



Extra receptacle package available on 20 kW upgrade only.

Control box shown with optional Roda Deaco air shutdown system.

LIGHT TOWER
AL5000

Specifications

30 ft (9.1 m) extended height floodlight produces enough light to illuminate 7-1/2 acres.

Self-braking, erecting and extending hand-operated winch with self-lubricating steel cable is mounted inside the cabinet.

Storage racks for light fixtures are also inside cabinet.

Spring-loaded pin automatically locks galvanized 360° rotatable tower in upright position.

Retractable power cord automatically recoils into protective rotatable mast sleeve to prevent damage when raising, lowering and moving tower.

Light fixtures plug into weatherproof receptacle box at top of tower with UL and CSA-approved connectors.

Individual quick-connect plug-in ballasts installed in galvanized steel boxes.

Control panel is inside, away from the elements. Houses main and branch circuit breakers and hourmeter.

Galvanized outriggers with pre-set position stops insure quick and proper spacing for safe operation in heavy winds.

Single point lifting eye and forklift pockets provided for easy loading and unloading.

Light Tower AL5000

Specifications - Standard Unit

Lamps	Metal Halide 4 x 1,000 W
Generator	Brushless 60 Hz, 8.0 kW
Engine	Kubota diesel 13.6 hp
Fuel capacity	30 gal (114 L)
Wheel size	15 in (38 cm)
Axle rating	3,500 lbs (1,588 kg)
Tongue weight travel position	220 lbs (100 kg)
Total weight no fuel	2,425 lbs (1,101 kg)

Specifications - 20 kW Upgrade

Lamps	Metal Halide 4 x 1,000 W
Generator	Brushless 60 Hz, 20 kW
Engine	Isuzu diesel 34.5 hp
Extra Receptacle Package	
3 each – 30 amp	125/250 volt Twistlock
2 each – 20 amp	120/240 volt GFCI
Fuel capacity	30 gal (114 L)
Wheel size	15 in (38 cm)
Axle rating	3,500 lbs (1,588 kg)
Tongue weight travel position	220 lbs (100 kg)
Total weight no fuel	2,735 lbs (1,245 kg)

Optional Equipment

Block heater	3/8" Highway safety chains with snap hook
Tough coat paint (front of unit and trailer)	
Plastic fenders	Spare tire and wheel
Rock shield (under entire unit)	Rubber door hold-down latches
60 gallon dual fuel tank system	Extra GFI duplex receptacle with breaker
Combination ring/ball hitch	Low temperature coolant mixture (-40 deg F)
Tail light package	Battery heater blanket
1000 CCA battery	Auto-start/stop**
Fuel line heater	Metal halide 6 x 1,000 W or 8 x 1,000 W lamps
Roda Deaco electronic air shutdown system*	

Dimensions

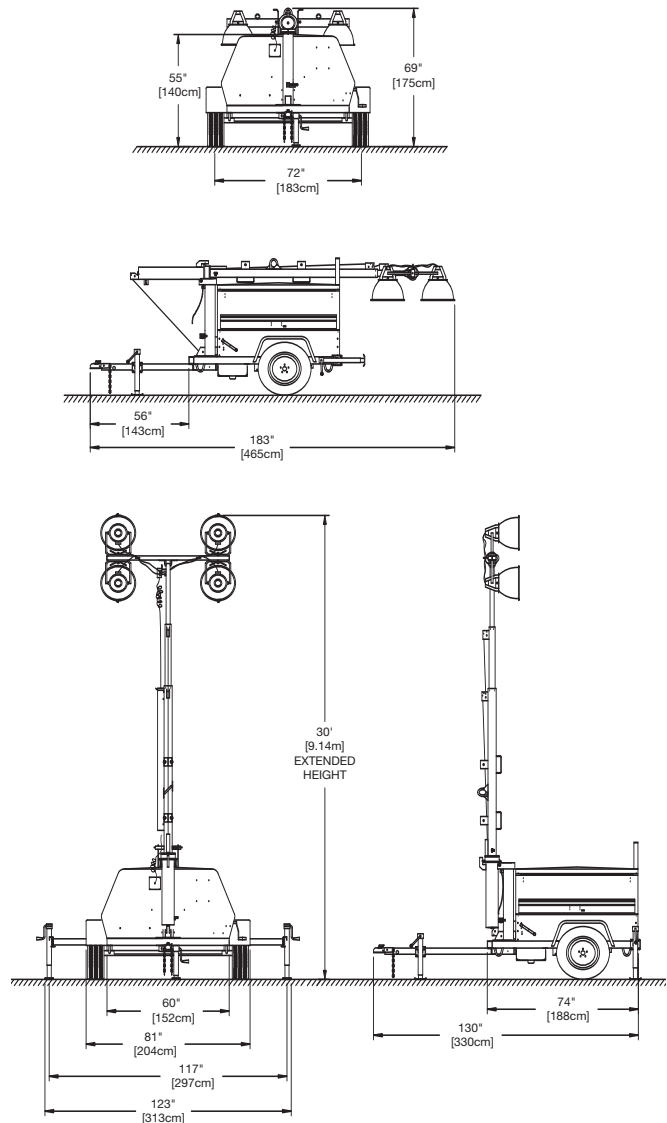

*Extra GFI and auto-start/stop not available with this system.

**Not available with 8 light configuration.



TEREX Light Construction

590 Huey Road TEL 803-324-3011
P.O. Box 3147 TOLL FREE 800-433-3026
Rock Hill, SC 29732 FAX 803-366-1101
USA EMAIL sales@terexlight.com
WEB www.terex.com

For more information, product demonstration, or details on purchase, lease and rental plans, please contact your local TEREX Light Construction Distributor.