

Light Tower
**LIGHT TOWER
AL8000 HT**

The unique articulated hydraulic mast is ideal for the mining industry, as well as use on railroad, municipal and large construction sites.

Specifications

Articulated hydraulic mast provides maximum flexibility and control for quick, effortless light positioning.

28 foot vertical height, 20 foot horizontal outreach and 359 degree powered rotation.

8 foot 2 inch stowed length provides for ease of transport for towing or transportation on a trailer or container.

Optional environmental spill containment to meet local regulations or for use in sensitive areas.

Light fixtures plug into weatherproof receptacle box at top of tower with UL and CSA-approved connectors.

Individual plug-in ballasts installed in galvanized steel boxes. Can be replaced without disconnecting wiring terminals.

Control panel is inside, away from the elements. Houses main and branch circuit breakers and hourmeter.

Galvanized outriggers with pre-set position stops ensure quick and proper spacing.

Single point lifting eye and forklift pockets provide for easy loading and unloading.

Optional Australian mining configuration designed specifically to meet Australian regulations and mining application requirements.

Light Tower AL8000 HT

Specifications - Standard Unit

Lamps	Metal Halide 4 x 1,000 W
Generator	Brushless 60 Hz, 8.0 kW
Mast Rotation	359° powered rotation
Light Bar Tilt	180°
Individual Light Pivot	180° front-to-back, 360° side-to-side
Engine	Kubota Diesel 13.6 hp
Fuel Capacity	30 gal (114 L)
Wheel Size	15 in (38 cm)
Axle Rating	4,200 lbs (1,905 kg)
Tongue weight travel position	375 lbs (170 kg)
Total weight no fuel	2,605 lbs (1,185 kg)

Dimensions

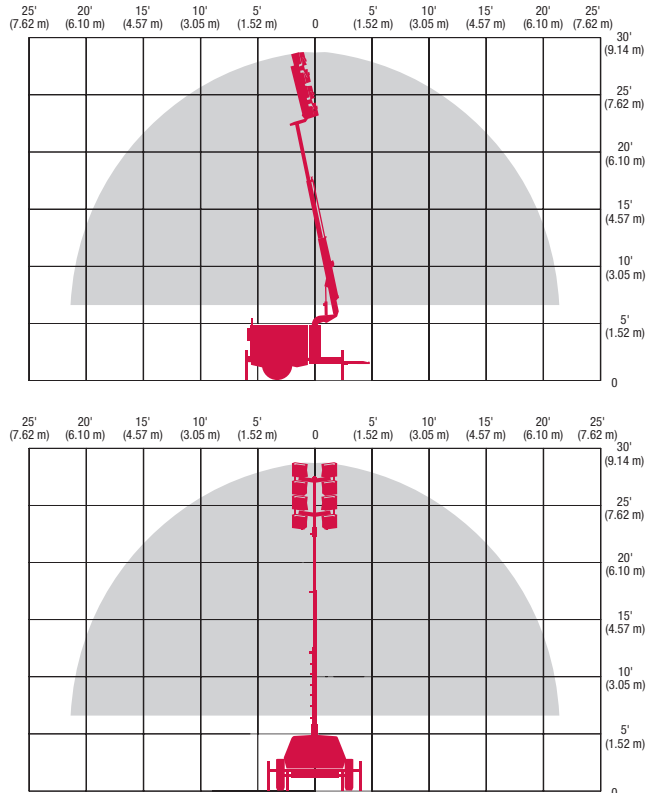

Optional Equipment

Metal Halide 8 x 1,000 W lamps	Tail light package
Brushless 60 Hz, 20 kW generator	Block heater
Brushless 60 Hz, 12 kW generator	Fuel line heater
Isuzu Diesel 34.5 hp engine	Roda Deaco air shutdown system
60 gal (228 L) fuel capacity	Australian mining configuration
Environmental spill containment	16 inch wheel size (Australia only)
Tough coat paint	
Combination ring/ball hitch	

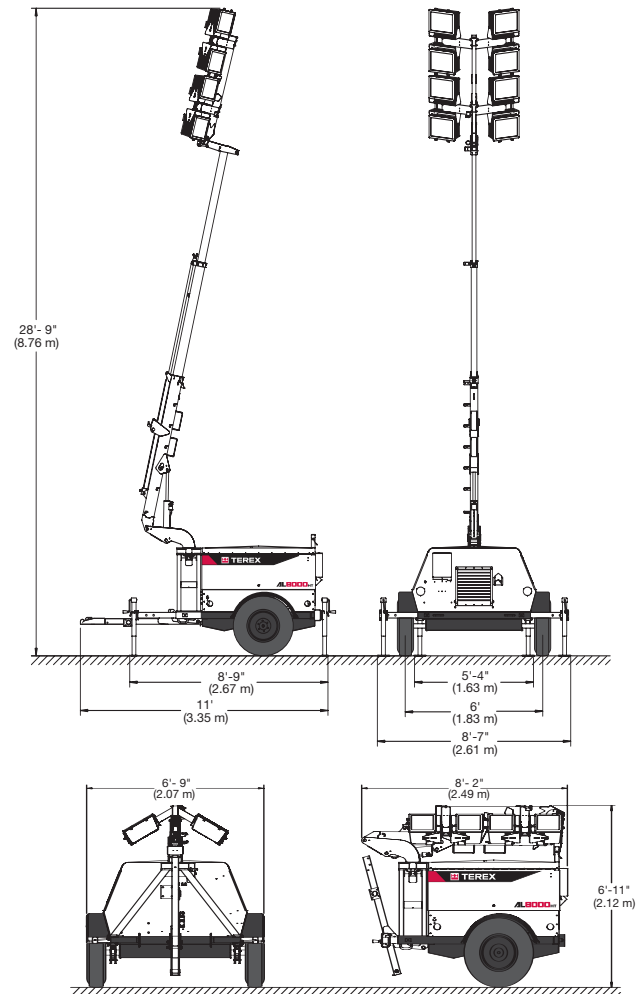

Genie Industries, Inc.

A Terex Company

18340 NE 76th Street
PO Box 97030
Redmond, WA 98073-9730
U.S.A.

TEL +1 425-881-1800
TOLL FREE +1 800-536-1800
PARTS & TECH SUPPORT +1 800-228-6444
FAX +1 425-883-8475
WEB www.genieindustries.com

For more information, product demonstration, or details on purchase, lease and rental plans, please contact your local Genie Distributor.

Effective Date: August 1, 2007. Product specifications and prices are subject to change without notice or obligation. The photographs and/or drawings in this document are for illustrative purposes only. Refer to the appropriate Operator's Manual for instructions on the proper use of this equipment. Failure to follow the appropriate Operator's Manual when using our equipment or to otherwise act irresponsibly may result in serious injury or death. The only warranty applicable to our equipment is the standard written warranty applicable to the particular product and sale and we make no other warranty, express or implied. Products and services listed may be trademarks, service marks or trade-names of Terex Corporation, Genie Industries, Inc. and/or their subsidiaries in the U.S.A. and many other countries and all rights are reserved. Terex® is a Registered Trademark of Terex Corporation in the U.S.A. and many other countries. Genie® is a Registered Trademark of Genie Industries, Inc. in the U.S.A. and many other countries. Genie is a Terex Company. © 2007 Terex Corporation.