

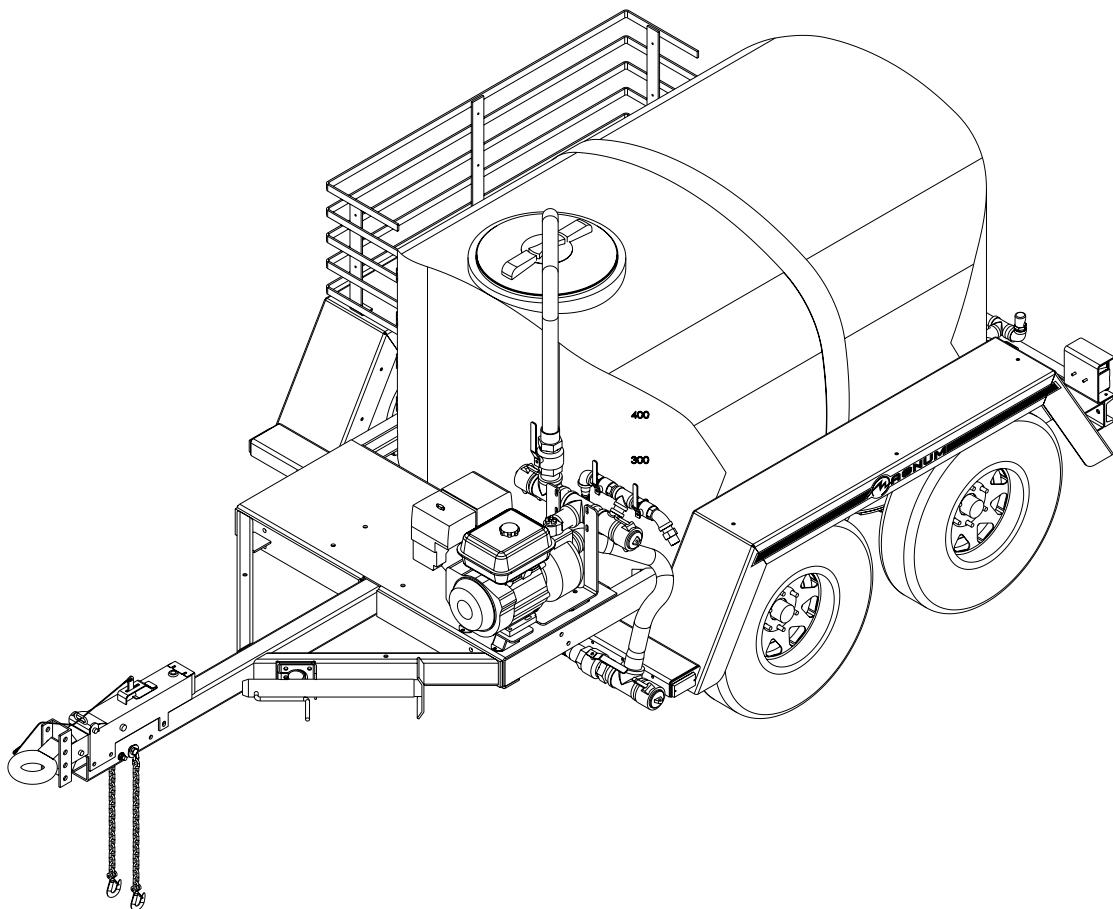

WATER TRAILER
MODEL MWT0500



OPERATORS MANUAL / PARTS BOOK

NOTES:

Engine Make:_____

Engine Serial #:_____

Engine Model #:_____

Pump Make:_____

Pump Model #:_____

Pump Serial #:_____

Unit Model #:_____

Unit Serial #:_____

This manual provides information and procedures to safely operate and maintain the water trailer and pump unit. For your own safety and protection from physical injury, carefully read, understand, and observe the safety instructions described in this manual. THE INFORMATION CONTAINED IN THIS MANUAL WAS BASED ON MACHINES IN PRODUCTION AT THE TIME OF PUBLICATION. MAGNUM PRODUCTS, LLC. RESERVES THE RIGHT TO CHANGE ANY PORTION OF THIS INFORMATION WITHOUT NOTICE.

An engine and pump operators manual was supplied with the machine at the time of its shipment from the factory. These manuals provide detailed operation and maintenance procedures for the engine and pump. Additional copies of this manual are available from the engine and pump manufacturers.

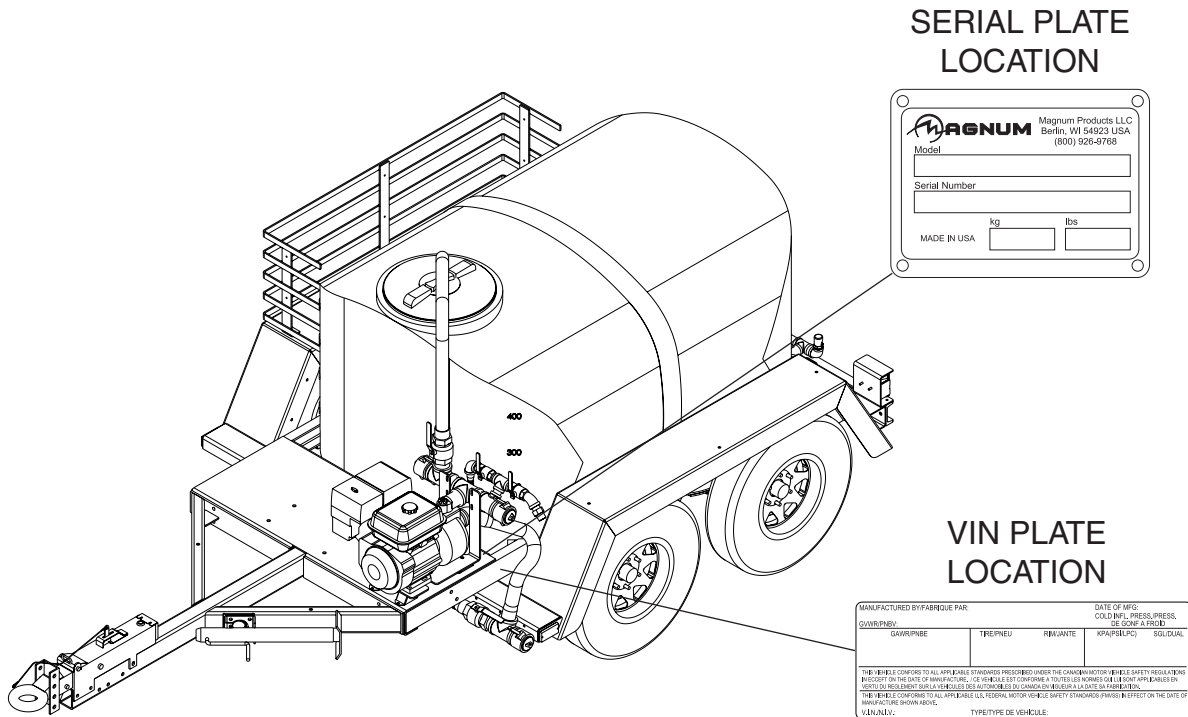

MAGNUM PRODUCTS, LLC
215 POWER DRIVE
BERLIN, WI 54923

PHONE: 920-361-4442
FAX: 920-361-4416
TOLL FREE: 1-800-926-9768

www.m-p-llc.com

TABLE OF CONTENTS

INTRODUCTION	PAGE 3
TABLE OF CONTENTS	PAGE 4
SPECIFICATIONS	PAGE 5
SAFETY GUIDELINES	PAGES 6 - 7
FILLING THE WATER TRAILER	PAGE 8
DISCHARGING FROM THE WATER TRAILER	PAGE 9
PUMP SAFETY	PAGE 10
REAR SPRAY BAR ADJUSTMENT	PAGE 10
WATER TRAILER MAINTENANCE	PAGES 10 - 11
DRAINING THE TANK	PAGE 11
DECAL LOCATIONS	PAGE 12
TRAILER WIRING DIAGRAM	PAGE 13
ELECTRIC BRAKE WIRING DIAGRAM	PAGE 13
ENGINE AND PUMP ASSEMBLY	PAGES 14 - 15
TANK ASSEMBLY	PAGES 16 - 17
FRAME COMPONENTS	PAGES 18 - 19
FRAME COMPONENTS, NEW STYLE	PAGES 20 - 21
HYDRAULIC BRAKE AXLE ASSEMBLY	PAGES 22 - 23
ELECTRIC BRAKE AXLE ASSEMBLY	PAGES 24 - 25
UPPER AND LOWER MANIFOLD ASSEMBLY	PAGES 26 - 27
FILL HOSE ASSEMBLY	PAGES 28 - 29
DISCHARGE HOSE ASSEMBLIES	PAGES 30 - 31

NOTE: THIS UNIT WAS SHIPPED FROM THE FACTORY WITH THE ACCESSORIES AND HOSES INSIDE THE TANK. REMOVE THE HOSES AND ACCESSORIES BEFORE USING THIS EQUIPMENT. MAKE SURE ALL ITEMS ARE SECURED TO THE HOSE STORAGE BIN BEFORE MOVING OR TOWING THE WATER TRAILER. FAILURE TO DO SO MAY RESULT IN LOSS OF EQUIPMENT AND PROPERTY DAMAGE OR PERSONAL INJURY TO OTHERS.

MAKE SURE ALL HOSES AND ACCESSORIES ARE **SECURED TO THE BIN** BEFORE MOVING OR TOWING THE TRAILER.

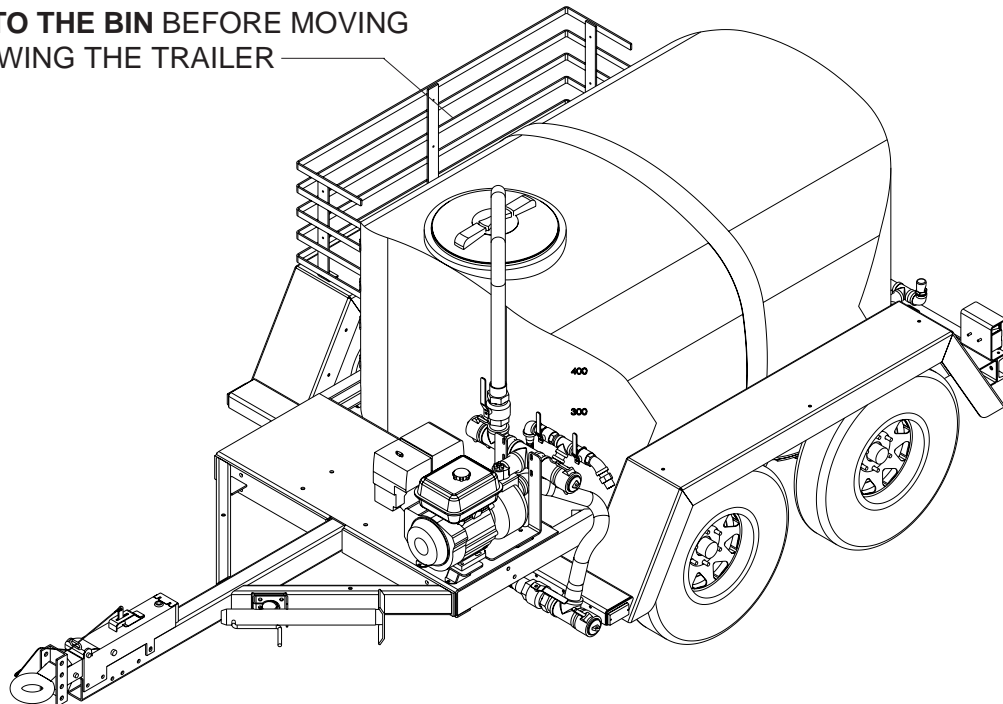

SPECIFICATIONS

PUMP MANUFACTURER:	TSURUMI
PUMP MODEL:	TE2-50HA
PUMP TYPE:	CENTRIFUGAL
PUMP INLET/OUTLET:	2-INCH
ENGINE MANUFACTURER:	HONDA
ENGINE MODEL:	GX 120
ENGINE OIL REQUIREMENTS:	SEE ENGINE OWNER'S MANUAL
PUMP OUTPUT:	137 gal/min (520 l/min)
WATER TANK CAPACITY:	500 gal (1895 liters)
WATER FILL RATE:	Full tank (500 gal) in 3-4 minutes @ full throttle
EMPTY WEIGHT OF TRAILER:	1740 Lbs.
TRAILER WEIGHT W/ FULL WATER TANK:	5740 Lbs.
TRAILER TIRE SIZE	225/75R15
TRAILER TIRE LOAD RANGE:	D
TRAILER BRAKING SYSTEM:	HYDRAULIC (ELECTRIC OPTIONAL)
TRAILER BRAKE FLUID:	DOT 3 HEAVY DUTY
HITCH TYPE:	3" TOW RING

TOWING SAFETY

Towing a trailer requires care! Both the trailer and vehicle must be in good condition and securely fastened to each other to reduce the possibility of an accident. **Reduce speed when the tank is filled with water. The tank is not baffled, so there will be a noticeable water surge in the tank under heavy braking.**

- Check that the hitch and coupling on the towing vehicle are rated equal to, or greater than, the trailer's "gross vehicle weight rating" (GVWR).

Inspect the hitch and coupling for wear or damage. **DO NOT** tow trailer using defective parts!
- Make sure the trailer hitch and the coupling are compatible. Make sure the coupling is securely fastened to the vehicle.
- Check tires on trailer for tread wear, inflation, and condition.
- Connect safety chains in a crossing pattern under the tongue and attach the brake away cable **TO THE REAR BUMPER OF THE TOWING VEHICLE**. Do not attach the cable to the trailer hitch.
- Make sure directional and brake lights on the trailer are connected and working properly.
- Check that lug nuts holding wheels are tight and that none are missing.
- Check the level of the brake fluid reservoir in the surge coupler on the tongue.

TOWING SPEEDS

The maximum recommended towing speed for the MWT0500 water trailer are as follows:

With the tank empty, improved road:	55 m.p.h.
With the tank full, improved road:	45 m.p.h.
With the tank 1/2 full, improved road:	45 m.p.h. or less
Any towing on unimproved roads:	20 m.p.h. or less

Before towing the trailer, check that the weight of the trailer is equal across all four trailer tires. A large angle between the trailer and tow vehicle will cause more weight to be carried by one axle, which could cause premature wear on the tires and axles and cause potentially unsafe operating conditions. Adjust the angle of the trailer tongue to keep the trailer as level as possible.

The trailer is equipped with hydraulic surge brakes, or optional electric surge brakes. Check the operation of the brakes by braking the vehicle at a slow speed before entering traffic. Both the trailer and the vehicle should brake smoothly. If the trailer seems to be pushing, check the level in the surge brake fluid reservoir.

When towing, maintain extra space between vehicles and avoid soft shoulders, curbs and sudden lane changes. If you have not pulled a trailer before, practice turning, stopping, and backing up in an area away from heavy traffic.

A film of grease on the coupler will extend coupler life and eliminate squeaking. Wipe the coupler clean and apply fresh grease each time the trailer is towed.

REPORTING TRAILER SAFETY DEFECTS

If you believe your trailer has a defect which could cause a crash or could cause injury or death, you should immediately inform the National Highway Traffic Safety Administration (NHTSA) in addition to notifying Magnum Products, Inc. If NHTSA receives similar complaints, it may open an investigation; and if it finds that a safety defect exists in a group of vehicles, it may order a recall and remedy campaign. However, NHTSA cannot become involved in individual problem between you, your dealer, or Magnum Products, Inc.

To contact NHTSA, you may either call the Auto Safety Hotline toll-free at 1-888-327-4236 or by fax at: (202)-366-7882. Letters can be addressed to:

U.S. Department of Transportation
National Highway Traffic Safety Administration
Office of Defects Investigation
NSA-10.01, 400 7 th street, SW
Washington, DC 20590

OPERATING SAFETY

Before using the water trailer, be sure you read and understand all instructions! Equipment operated improperly or by untrained personnel can be dangerous! Read the operating instructions and familiarize yourself with the location and proper use of all instruments and controls. Inexperienced operators should receive instruction from someone familiar with the equipment before being allowed to operate or set up the machine.

WARNING!

- The area immediately surrounding the water trailer should be clean, neat, and free of debris.
- Position and operate the water trailer on a firm, level surface.
- **NEVER** start a unit in need of repair.
- **NEVER** run the pump engine indoors or in an area with poor ventilation.
- **DO NOT** start the pump engine if fuel has spilled or if a strong odor of fuel is present.
- **ALWAYS** secure any hoses or accessories to the storage bin before moving the trailer.
- **NEVER** remove any of the instruction or safety decals from the trailer. If any are damaged or missing, contact your dealer or Magnum Products, Inc. for replacements.
- **DO NOT** enter the tank on the water trailer.
- **ALWAYS** keep the tank covers in place.
- The tank is NOT fire resistant. Never expose the tank to open flame or excessive heat.
- Protect the tank from sharp impacts, especially in cold temperatures. Keep sharp objects away from the tank to avoid punctures.
- **NEVER** leave the unit unattended while the pump is running.
- The tank can only be used with polyethylene tolerant fluids. Use of the tank with incompatible chemicals or solvents will cause leaks and/or tank failure.
- Keep all people and objects clear of the spray nozzles and hoses while the pump is running.
- Inspect all hoses and valves for cracks, bulges or leaks before each use.

ENGINE SAFETY

Internal combustion engines present special hazards during operation and fueling! Failure to follow the safety guidelines described below could result in severe injury or death. Also read and follow all safety warnings described in the Engine Operator's Manual. A copy of this manual was supplied with unit when it was shipped from the factory.

WARNING!

- **DO NOT** run engine indoors or in an area with poor ventilation unless exhaust hoses are used.
- **DO NOT** fill fuel tank near an open flame, while smoking, or while engine is running.
- **DO NOT** fill tank in an enclosed area with poor ventilation.
- **DO NOT** touch or lean against hot exhaust pipes or engine cylinder.
- **DO NOT** start the pump engine with the fuel tank cap loose or missing.
- **DO NOT** clean air filter with gasoline or other types of low flash point solvents.
- **DO NOT** add fuel to a hot or running engine.
- Check the oil level in the pump engine daily. Additional information regarding the correct type and grade of engine oil can be found in the engine owner's manual supplied with this unit.
- Keep area around exhaust pipes and air ducts free of debris to reduce the chance of an accidental fire.
- Prolonged exposure to sound levels in excess of 85 DBA can cause permanent hearing loss. Wear hearing protection when working near a running pump engine.

FILLING THE WATER TRAILER

To fill the tank from a hydrant:

1. Remove the tank covers (A).
2. Open valve 1 and close valves 2, 3 and 4. Make sure the gravity drain bibb (H) is closed.
3. Attach the hydrant adapter to the hydrant. Attach the threaded end of the 2" rigid fill hose to the hydrant adapter.
4. Remove the end plug (B) from the upper manifold. Attach the cam-lock fitting on the 2" rigid fill hose to the manifold and secure the cam-lock fitting. Make sure there are no bends or sharp kinks in the fill hose.
5. Slowly open the hydrant valve. The tank should begin to fill from the supply pipe (C) by the municipal water pressure.
6. Fill the tank to the desired level and close the hydrant valve.
7. Remove the 2" rigid fill hose from the hydrant and allow the hose to drain. Remove the hydrant adapter and then remove the hose from the cam-lock fitting on the upper manifold. Return the hose and hydrant adapter to the storage bin.
8. Replace the end plug on the upper manifold (B) and secure the cam-lock fitting.
9. Replace the tank covers (A).

To fill the tank from a body of water.

1. Remove the tank covers (A).
2. Open valves 1 and 4 and close valve 2 and 3. Make sure the gravity drain bibb (H) is closed.
3. Remove the end plug from the lower manifold (D). Attach the cam-lock end of the 2" rigid fill hose to the cam-lock fitting (D).
4. Attach the basket strainer to the threaded end of the 2" rigid fill hose and put the hose into the water supply.
5. Prime the pump by filling the pump housing through the access hole (E) on the top of the pump housing. Start the pump engine. Refer to the engine owner's manual for proper starting and operation procedures. The tank should begin to fill from the supply pipe (C).
6. Fill the tank to the desired level and stop the pump engine.
7. Close valve 1. Remove the 2" rigid fill hose from the cam-lock fitting on the lower manifold (D) and allow the hose to drain. Return the hose to the storage bin.
8. Replace the end plug on the lower manifold (D) and secure the cam-lock fitting.
9. Replace the tank covers (A).

BALL VALVE OPERATION

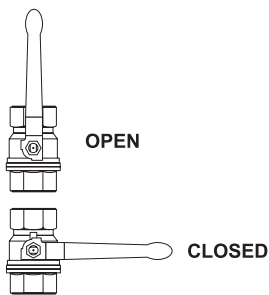

CAM-LOCK FITTINGS

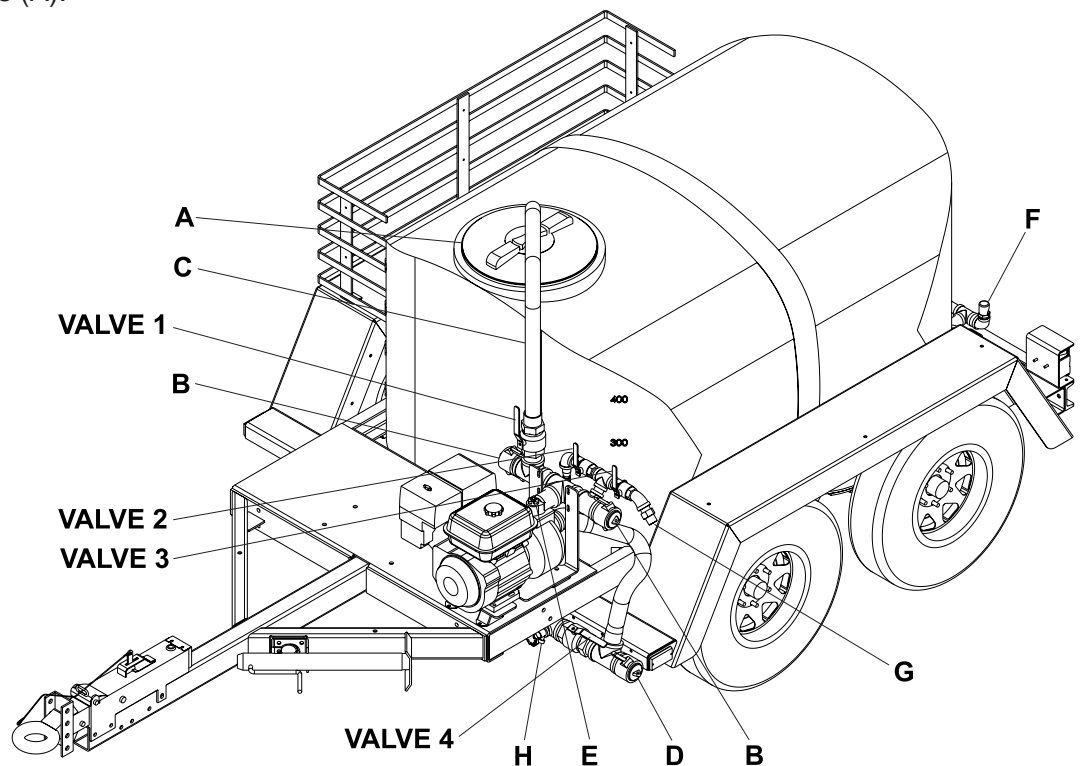
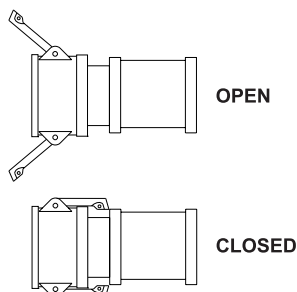

DISCHARGING FROM THE WATER TRAILER

To discharge from the rear spray nozzles:

1. Open valve 4 and close valves 1, 2 and 3. Make sure the gravity drain bibb (H) is closed.
2. Start the pump engine. Refer to the engine owner's manual for proper starting and operation procedures.
3. With the engine running, open valve 2. The tank should now discharge from the rear spray nozzles (F).
4. If required, tow the trailer through the desired area. Keep the trailer level by adjusting the ring hitch on the surge brake coupler.
7. Once the tank is empty, shut the pump engine off. Close valves 1 and 4.

To discharge from the 2" flexible spray hose:

1. Close valves 1, 2, 3 and 4. Make sure the gravity drain bibb (H) is closed.
2. Remove the end plug (B) from either side of the upper manifold. Attach the cam-lock fitting on the 2" flexible spray hose to the manifold and secure the cam-lock fitting. Make sure there are no sharp bends or kinks in the 2" flexible spray hose and make sure the nozzle is closed.
3. Open valve 4.
4. Start the pump engine. Refer to the engine owner's manual for proper starting and operation procedures. The 2" flexible spray hose should pressurize and be ready for use.
5. Once the tank is empty, shut the pump engine off. Remove the 2" flexible spray hose from the upper manifold and allow the hose to drain. Return the hose to the storage bin.
6. Replace the end plug on the upper manifold (B) and secure the cam-lock fitting.
7. Close valve 4.

To discharge from the 5/8" flexible spray hose:

1. Close valves 1, 2, 3 and 4. Make sure the gravity drain bibb (H) is closed.
2. Attach the 5/8" flexible spray hose to the fitting (G) on the end of the upper manifold. Make sure there are no sharp bends or kinks in the 5/8" flexible spray hose.
3. Open valve 4.
4. Start the pump engine. Refer to the engine owner's manual for proper starting and operation procedures.
5. Open valve 3, the 5/8" flexible spray hose should pressurize and be ready for use.
6. Once the tank is empty, shut the pump engine off. Remove the 5/8" flexible spray hose from the upper manifold and allow the hose to drain. Return the hose to the storage bin.
7. Close valves 3 and 4.

To discharge from the lower manifold gravity drain bibb:

1. Close valves 1, 2, 3 and 4.
2. Attach the 5/8" flexible spray hose to the lower hose bibb (H). Make sure there are no sharp bends or kinks in the 5/8" flexible spray hose.
3. Open the lower hose bibb (H). The tank should drain through the 5/8" flexible spray hose.
4. Once the tank is empty, close the lower hose bibb (H). Remove the 5/8" flexible spray hose from the lower hose bibb (H) and allow the hose to drain. Return the hose to the storage bin.

WARNING!

DO NOT allow the pump to run dry for more than two minutes or run the pump engine with all of the valves closed. This will overheat the pump and cause damage. Never leave the unit unattended when the pump engine is running!

SAFETY PRECAUTIONS WHEN OPERATING THE PUMP

1. **DO NOT** drive over the hoses while they are pressurized or if the pump is running. This will cause a rapid increase/decrease in line pressure that could break or damage the pump engine, pump housing or rupture hoses on the unit.
2. Keep all people and objects clear of all spray nozzles when the pump is running.
3. **DO NOT** reach into the pump housing to clear debris when the pump engine is running.
4. **NEVER** perform any maintenance on any of the spray nozzles, valves or hoses when the pump engine is running.
5. Shut the pump engine off if any of the following conditions exist:
 - Noticeable change in engine speed.
 - Excessive pump or engine vibration.
 - Engine misfires or sparking occurs.
 - Operating on a combustible surface.

REAR SPRAY BAR ADJUSTMENT

The rear spray bar discharges water in a fan shaped pattern, approximately 32 feet wide. Depending on the application or job requirements, the spray pattern can be adjusted in a wider or narrower pattern.

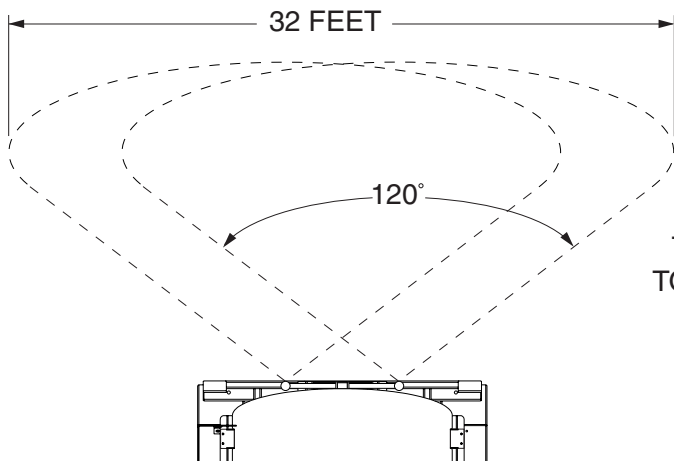

TURN THE SPRAY NOZZLES
TO ADJUST THE SPRAY WIDTH

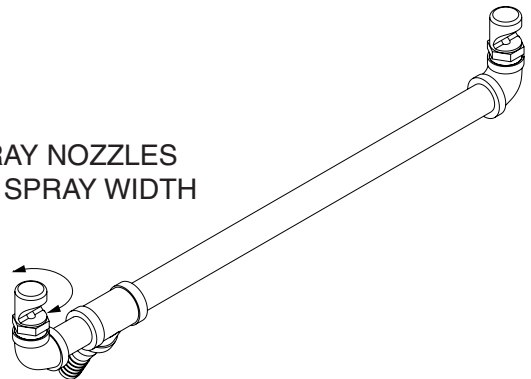

WATER TRAILER MAINTENANCE

The following items should be checked EVERY DAY:

- Engine oil level in the pump engine.
- All hoses, valves and couplings for leaks or bulges.
- Brake fluid level in the surge brake coupler or battery connections on electric brake models.
- Trailer tires for proper inflation and wear.
- All trailer lights and wiring.
- Make sure all of the hoses and accessories are accounted for and securely fastened to the storage bin.
- Check all lug nuts on the trailer wheels for tightness.
- Check all hardware for tightness. Tighten or replace any loose or missing components.

- Grease the trailer axle bearings every three months, or 1000 miles.

Keep the water trailer free of mud, oil or chemicals. When washing the trailer, do not spray water on the engine or surge brake coupler. Replace any missing or hard to read decals immediately; contact your dealer or Magnum Products, LLC for replacements.

This water trailer is designed for specific applications. Do not modify or use this unit for any application other than which it was designed.

PUMP AND ENGINE MAINTENANCE

Consult the pump instruction manual and the engine owner's manuals that were supplied with this unit for periodic maintenance procedures. If the water trailer is going to be stored for a long period of time certain precautions must be taken to insure reliable start up the next time the water trailer is used. Consult the pump instruction manual and the engine owner's manuals that were supplied with this unit for long term storage procedures.

DRAINING THE TANK

The tank, pump housing and hoses must be completely drained when the temperature is expected to drop below 32°F (0°C) or if the unit is to be stored for a long period of time. To drain the unit:

1. Lower the front of the trailer as low as possible using the trailer jack.
2. Open the lower hose bibb (H) and valve 4 and allow the tank and lower manifold to drain completely.
3. Close valve 4.
4. Raise the front of the trailer with the trailer jack until the pump engine is at a slight angle.
5. Drain the pump housing by removing the drain plug. The drain plug is located directly below the pump inlet hose. Replace the drain plug when the housing is empty.
6. Close valves 1, 2, 3 and 4. Remove the end plug (B) on the upper manifold.
7. Remove the plug to the access hole (E) on the top of the pump housing. Using an air compressor, blow air into the pump housing. The remaining water in the outlet side of the pump and hose should discharge through the end of the manifold.
8. Replace the end cap in the upper manifold. Open valve 2 and blow air into the pump housing. Any water left in the supply hose to the rear spray bar should discharge through the rear spray nozzles.
9. Leave the lower hose bibb open to allow any residual water to drain from the tank.

BALL VALVE OPERATION

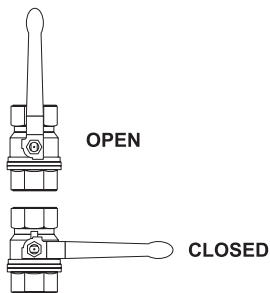

CAM-LOCK FITTINGS

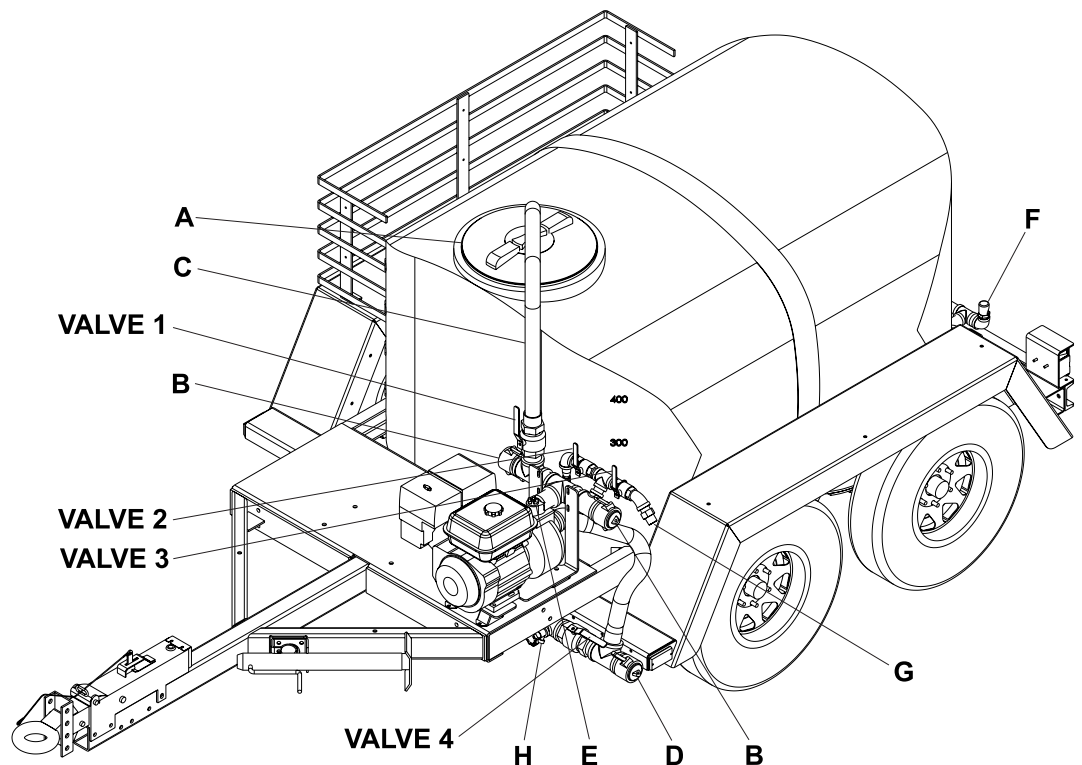
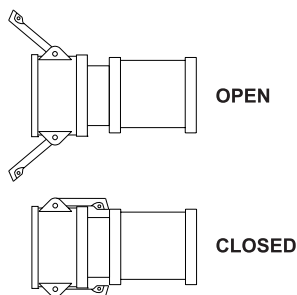

TRAILER WIRING DIAGRAM

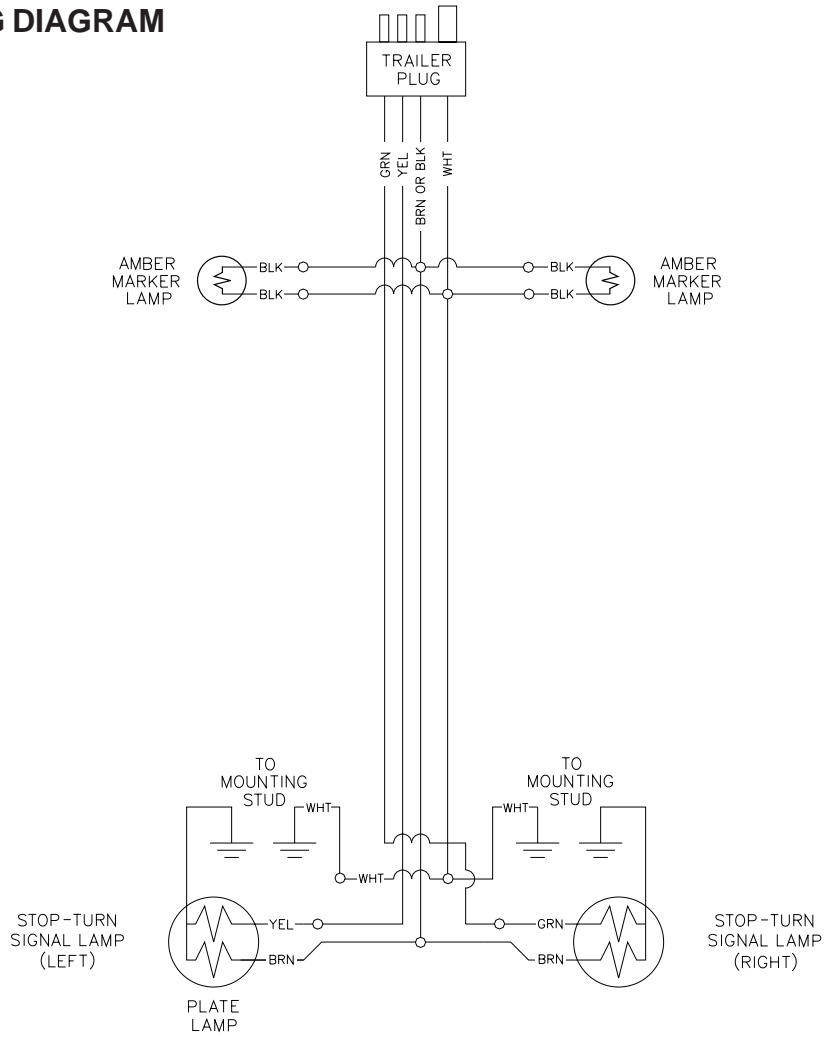

ELECTRIC BRAKE WIRING DIAGRAM

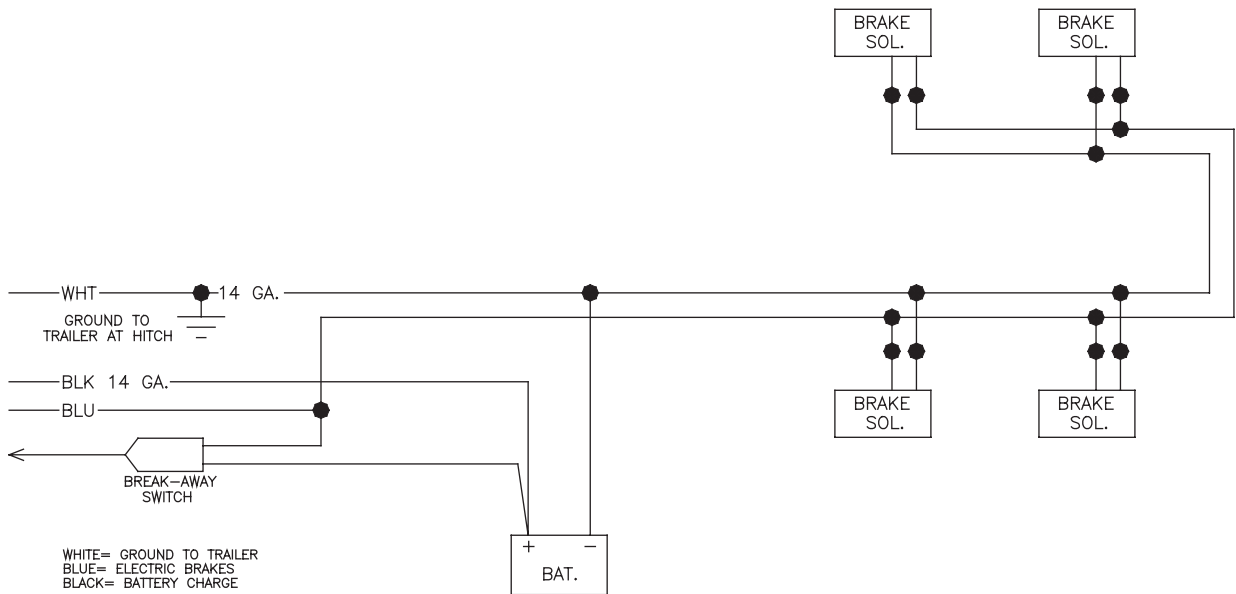

ENGINE AND PUMP ASSEMBLY

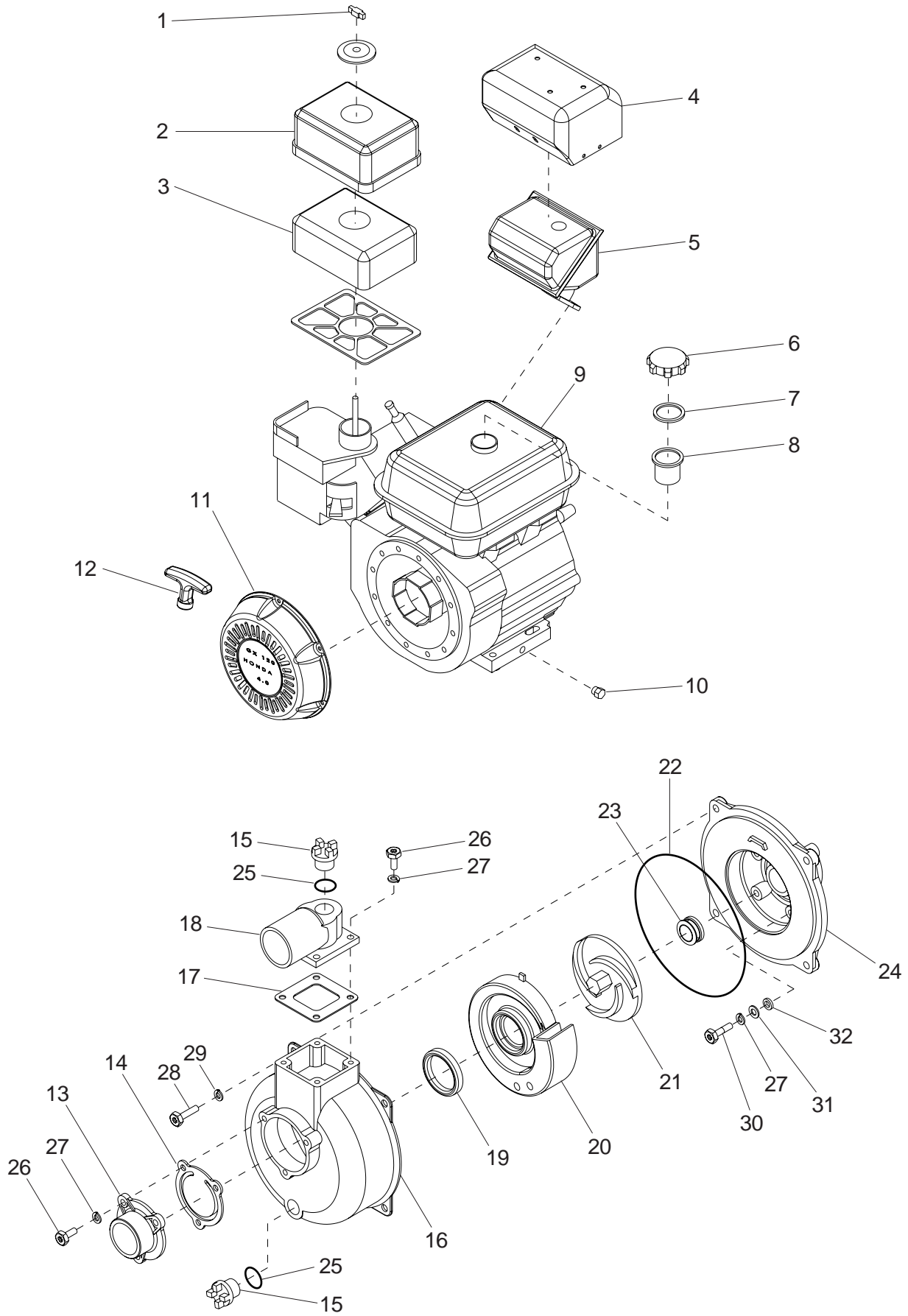

ENGINE AND PUMP ASSEMBLY

ITEM NO.	PART NO.	QTY	DESCRIPTION
1	40827	1	Wingnut, air cleaner Honda GX120
2	40828	1	Housing, air cleaner Honda GX120
3	40829	1	Element, air cleaner Honda GX120
4	40830	1	Guard, muffler Honda GX120
5	40831	1	Muffler, Honda GX120
6	40832	1	Cap, fuel tank Honda GX120
7	40833	1	Gasket, tank cap Honda GX120
8	40834	1	Strainer, fuel tank Honda GX120
9	40835	1	Tank, fuel Honda GX120
10	40836	1	Oil plug, Honda GX120
11	40837	1	Starter, rewind Honda GX120
12	40838	1	Handle, starter rope Honda GX120
13	40684	1	Flange, suction Tsurumi pump
14	11565	1	Valve, check Tsurumi pump
15	40688	2	Plug, pump housing Tsurumi
16	40676	1	Casing, pump Tsurumi
17	40687	1	Gasket, discharge bend
18	40686	1	Discharge bend, pump
19	40683	1	Seal, inner casing
20	40682	1	Casing, inner pump
21	40680	1	Impeller, pump
22	40677	1	O-ring, pump casing Tsurumi
23	40681	1	Seal, mechanical Tsurumi
24	40678	1	Cover, pump casing Tsurumi
25	40689	2	O-ring, pump plug
26	60441	7	Screw, M8 x 25 HX HD GR 8.8 SS
27	60341	11	Washer, split lock M8 SS
28	40841	4	Screw, M10 x 30 Tsurumi
29	40842	4	Washer, split lock M10 Tsurumi
30	40843	4	Screw, M8 x 50 1/2 thread Tsurumi
31	40844	4	Washer, flat M8 Tsurumi
32	40845	4	Seal, packing M8 washer Tsurumi
33	40846	1	Gasket set, valve cover Honda GX120
34	40847	1	Module, ignition Honda GX120
35	40848	1	Assembly, spark plug cap Honda GX120
36	40849	1	Switch, engine on/off Honda GX120
37	40850	1	Switch, low oil alert Honda GX120
38	40851	1	Plug, oil fill w/gasket Honda GX120
39	40852	1	Gasket set, carburetor Honda GX120
40	40853	1	Manual, workshop Honda GX120
41	40854	1	Manual, Tsurumi pump

TANK ASSEMBLY

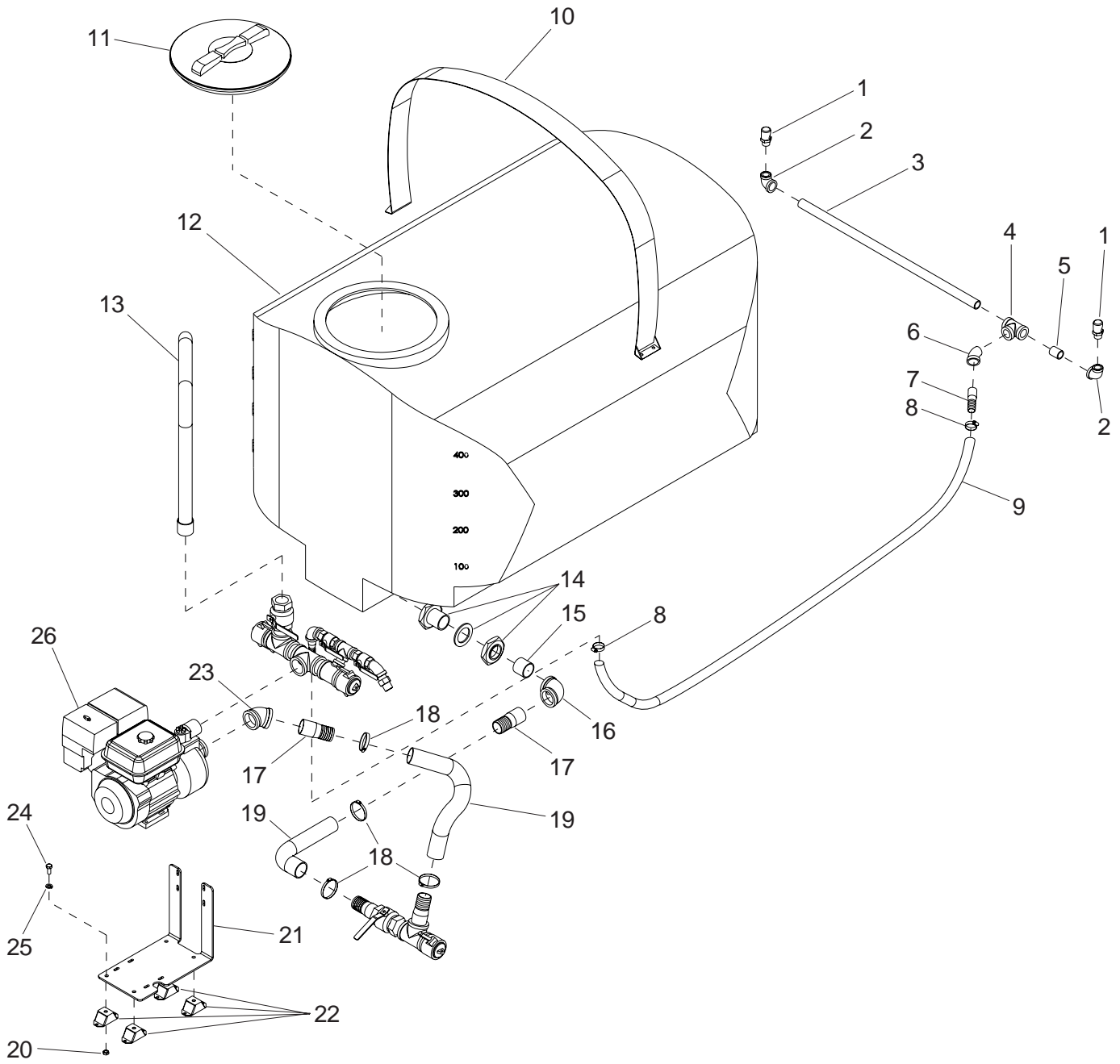

TANK ASSEMBLY

ITEM NO.	PART NO.	QTY	DESCRIPTION
1	40233	2	Fitting, fog nozzle
2	40232	2	Fitting, 1" NPT x 3/4" NPT 90
3	40793	2	Nipple, pipe 1" NPT x 38"
4	40231	1	Fitting, tee 1" NPT x 1" NPT
5	40276	1	Nipple, pipe 1" NPT x close
6	40794	1	Fitting, 1" NPT 45 deg street elbow
7	21451	1	Fitting, 1" NPT x 1" barb
8	19338	4	Clamp, hose - SAE 16 (.68-1.50)
9	40803	1	Hose, rubber 1" x 7'
10	40789B	1	Weldment, tank strap
11	40756	1	Cover, water tank - 16.00 MWT 0500
12	40768	1	Tank, water - 500 gallon
13	40797B	1	Weldment, fill pipe
14	40740	1	Fitting, bulkhead - 2.00NPT POLY
15	21127	1	Nipple, pipe 2"NPT x 2.00
16	40226	1	Fitting, 2"NPT 90 deg elbow
17	40222	3	Fitting, 2.00MNPT x 2.00 hose shank
18	60316	8	Clamp, hose - SAE 32 (1.56-2.50)
19	40812	2	Hose, water 2.00 x 36.00
20	60307	4	Nut, .500-13 hx nylock
21	40784B	1	Bracket, engine/pump support
22	15241	4	Compression mount, engine/generator
23	40462	1	Fitting, 2.00 NPT 45 deg elbow
24	60275	4	Screw, .500-13x1.000 HX HD
25	60276	4	Washer, split lock .500
26	40247	1	Assembly, pump/engine

FRAME COMPONENTS

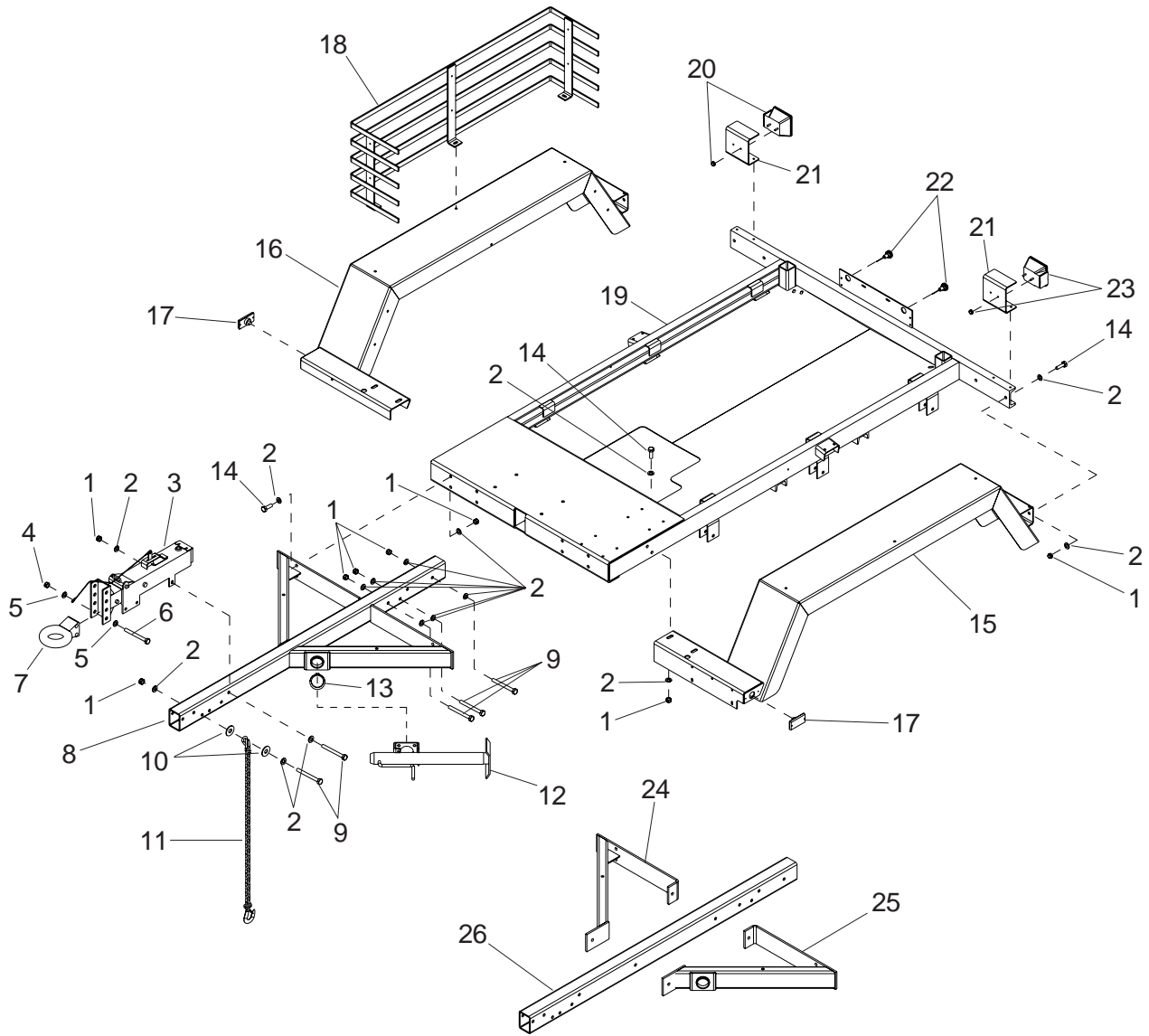

FRAME COMPONENTS

ITEM NO.	PART NO.	QTY	DESCRIPTION
1	60307	20	Nut, .500-13 hx nylock
2	60416	40	Washer, flat .500
3	40529	1	Actuator, adjustable hydraulic
4	60240	2	Nut, .625-11 hx nylock
5	60180	4	Washer, flat .625
6	60239	2	Screw, .625-11 x 5.00 hx hd GR5
7	19335	1	Hitch, pintle eye - 3.00
8	40743B	1	Weldment, tongue - water trailer
9	60659	8	Screw, .500-13 x 5.00 hx hd GR5
10	60671	4	Washer, fender .500
11	23367	2	Chain, safety - 7,800 lbs rated
12	11682	1	Jack, top wind
13	14326	1	Ring, retaining
14	60388	12	Screw, .500-13 x 1.500 hx hd GR5
15	40775B	1	Weldment, fender
16	40774B	1	Weldment, fender
17	65407	2	Light, clearance marker - amber
18	40770B	1	Weldment, hose storage
19	40522B	1	Weldment, WT chassis
20	65448	1	Light, stop/turn/tail waterproof rh
21	40776B	2	Bracket, tail light
22	19207	2	Light, license plate assy.
23	65449	1	Light, stop/turn/tail waterproof lh
* 24	11580B	1	Weldment, tongue
* 25	11581B	1	Weldment, tongue w/jack plate
* 26	11577B	1	Tongue, water trailer

* New style 3-piece tongue replaces item 8; part number 40743B.

FRAME COMPONENTS, NEW STYLE

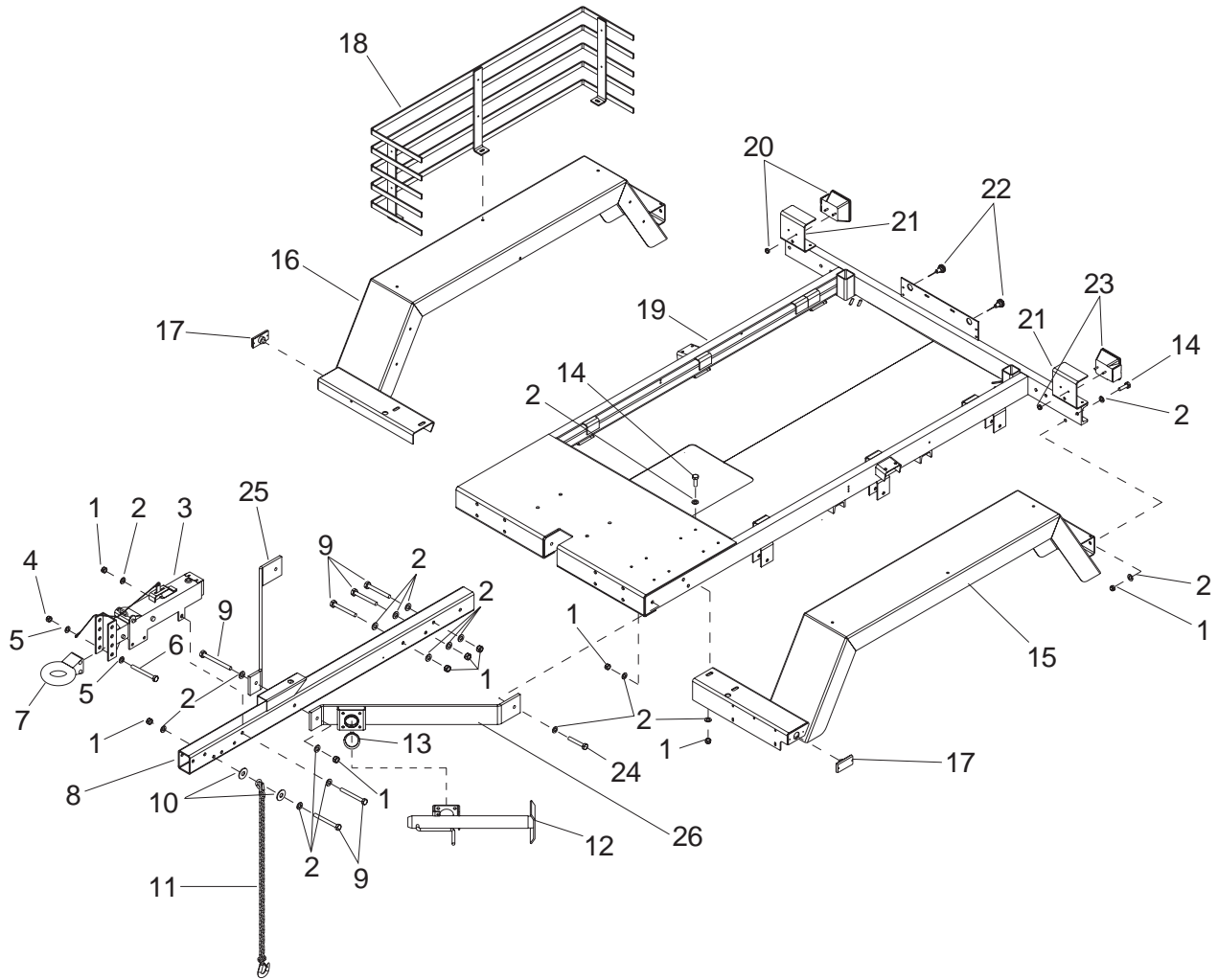

FRAME COMPONENTS, NEW STYLE

ITEM NO.	PART NO.	QTY	DESCRIPTION
1	60307	23	Nut, .500-13 hx nylock
2	60416	46	Washer, flat .500
3	40529	1	Actuator, adjustable hydraulic
4	60240	2	Nut, .625-11 hx nylock
5	60180	4	Washer, flat .625
6	60239	2	Screw, .625-11 x 5.00 hx hd GR5
7	19335	1	Hitch, pintle eye - 3.00
8	40953B	1	Weldment, tongue - water trailer
9	60659	9	Screw, .500-13 x 5.00 hx hd GR5
10	60671	4	Washer, fender .500
11	20159	2	Chain, trailer safety hi test
12	14223	1	Jack, side wind - 2000lb
13	14326	1	Ring, retaining
14	60388	12	Screw, .500-13 x 1.500 hx hd GR5
15	40775B	1	Weldment, fender
16	40774B	1	Weldment, fender
17	65407	2	Light, clearance marker - amber
18	40770B	1	Weldment, hose storage
19	40946B	1	Weldment, WT chassis
20	65448	1	Light, stop/turn/tail waterproof rh
21	40776B	2	Bracket, tail light
22	19207	2	Light, license plate assy.
23	65449	1	Light, stop/turn/tail waterproof lh
24	60484	2	Screw, .500-13x2.000 hx hd GR5 ZP
25	40945B	1	Tongue brace
26	40944B	1	Weldment, tongue brace

HYDRAULIC BRAKE AXLE ASSEMBLY

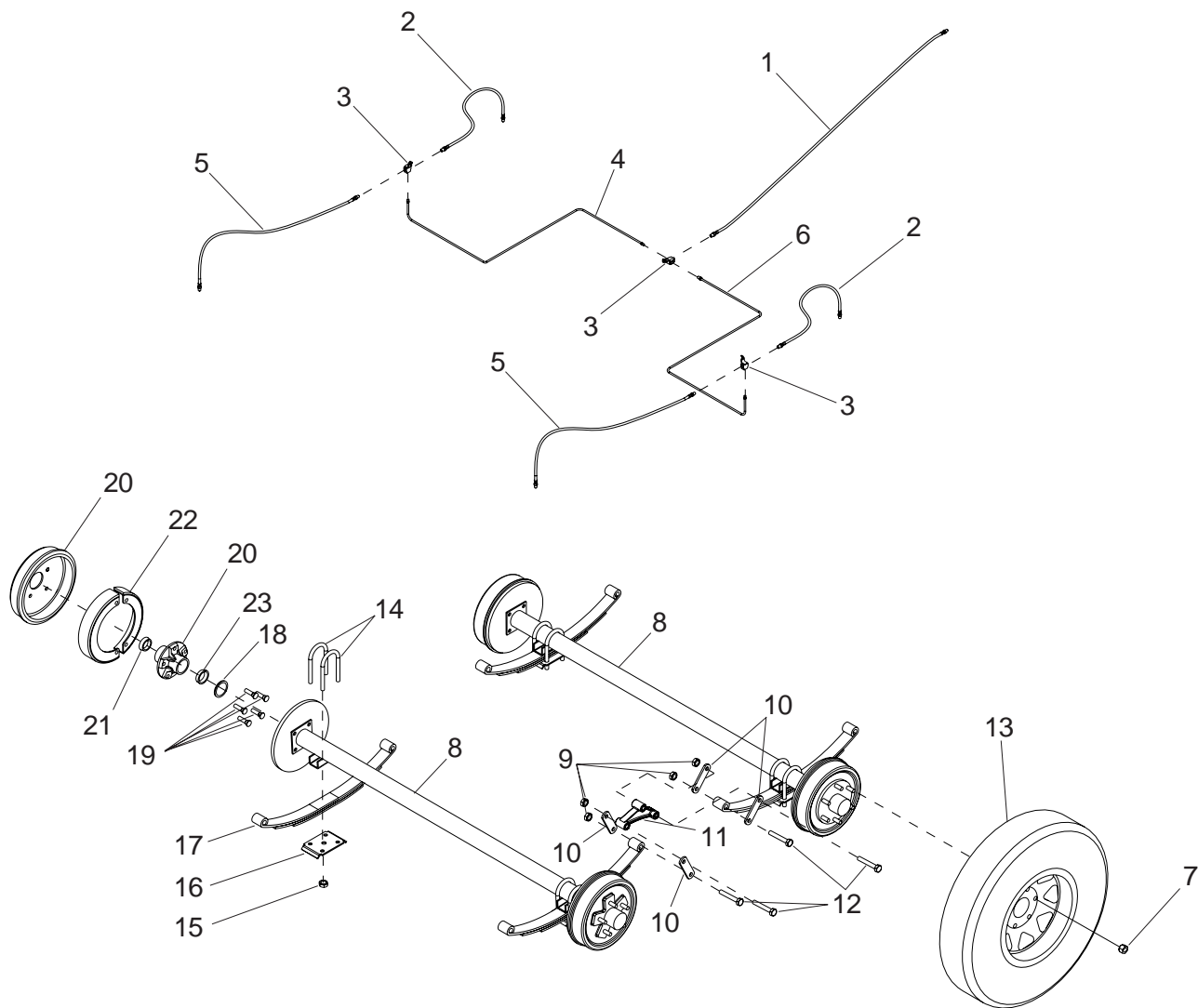

HYDRAULIC BRAKE AXLE ASSEMBLY

ITEM NO.	PART NO.	QTY	DESCRIPTION
1	40819	1	Hose, brake - .188 X 60.00 male/male
2	40818	2	Hose, brake - .188 X 12.00 male/male
3	19252	3	Fitting, brake line T - w/bracket
4	40857	1	Brake line, formed LH
5	40817	2	Hose, brake - .188 X 33.00 male/male
6	40858	1	Brake line, formed RH
7	60096	20	Lug nut, axle
8	40769	2	Axle, tandem hyd 3500LB 46SC 65TC
9	60504	14	Nut, .562-18 HX shackle lock
10	19367	8	Plate, shackle bracket
11	40545	2	Axle equalizer, tandem
12	60503	10	Screw, .562-18 HX shackle GR5
13	19786	4	Wheel, ST225 / 75 D 15, bias ply
14	23119	2	Bolt, U - 3500# axle
15	23118	4	Nut, U-bolt - 3500# axle (.500-20 locking)
16	23120	1	Plate, spring tie - 3500# axle
17	11280	1	Spring, 3500# axle
18	12461	1	Seal, axle bearing
19	60674	6	Stud, wheel - .500-20 GR8
20	40958	1	Axle hub/brake drum 3500 lb
21	40956	1	Bearing, axle outer
	40957	1	Race, axle outer bearing (not shown)
22	40959	4	Kit, brake shoes 3500#
23	40954	1	Bearing, axle inner
	40955	1	Race, axle inner bearing (not shown)
24	16755	1	Cap, grease (not shown)

ELECTRIC BRAKE AXLE ASSEMBLY

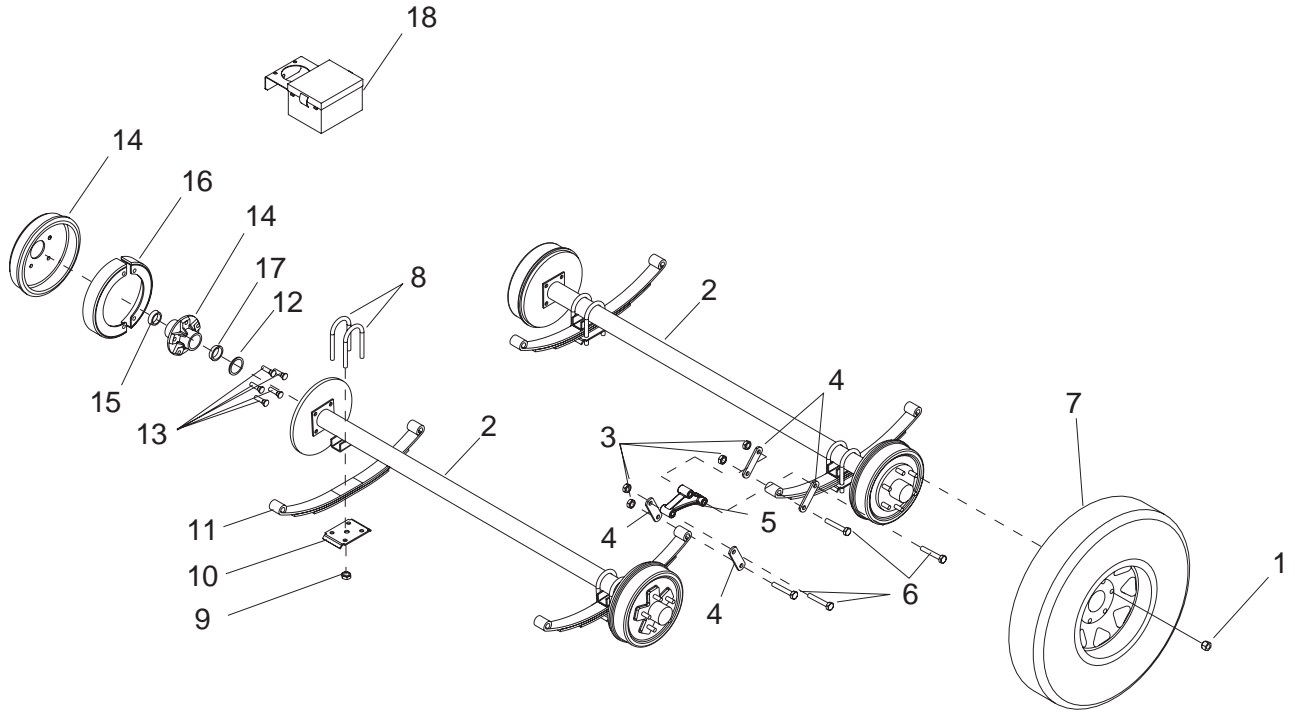

ELECTRIC BRAKE AXLE ASSEMBLY

ITEM NO.	PART NO.	QTY	DESCRIPTION
1	60096	20	Lug nut, axle
2	40769	2	Axle, tandem hyd 3500LB 46SC 65TC
3	60504	14	Nut, .562-18 HX shackle lock
4	19367	8	Plate, shackle bracket
5	40545	2	Axle equalizer, tandem
6	60503	10	Screw, .562-18 HX shackle GR5
7	19786	4	Wheel, ST225 / 75 D 15, bias ply
8	23119	2	Bolt, U - 3500# axle
9	23118	4	Nut, U-bolt - 3500# axle (.500-20 locking)
10	23120	1	Plate, spring tie - 3500# axle
11	11280	1	Spring, 3500# axle
12	12461	1	Seal, axle bearing
13	60674	6	Stud, wheel - .500-20 GR8
14	40958	1	Axle hub/brake drum 3500 lb
15	40956	1	Bearing, axle outer
	40957	1	Race, axle outer bearing (not shown)
16	40959	4	Kit, brake shoes 3500#
17	40954	1	Bearing, axle inner
	40955	1	Race, axle inner bearing (not shown)
18	19417	1	Breakaway kit
19	16755	1	Cap, grease (not shown)

UPPER AND LOWER MANIFOLD ASSEMBLY

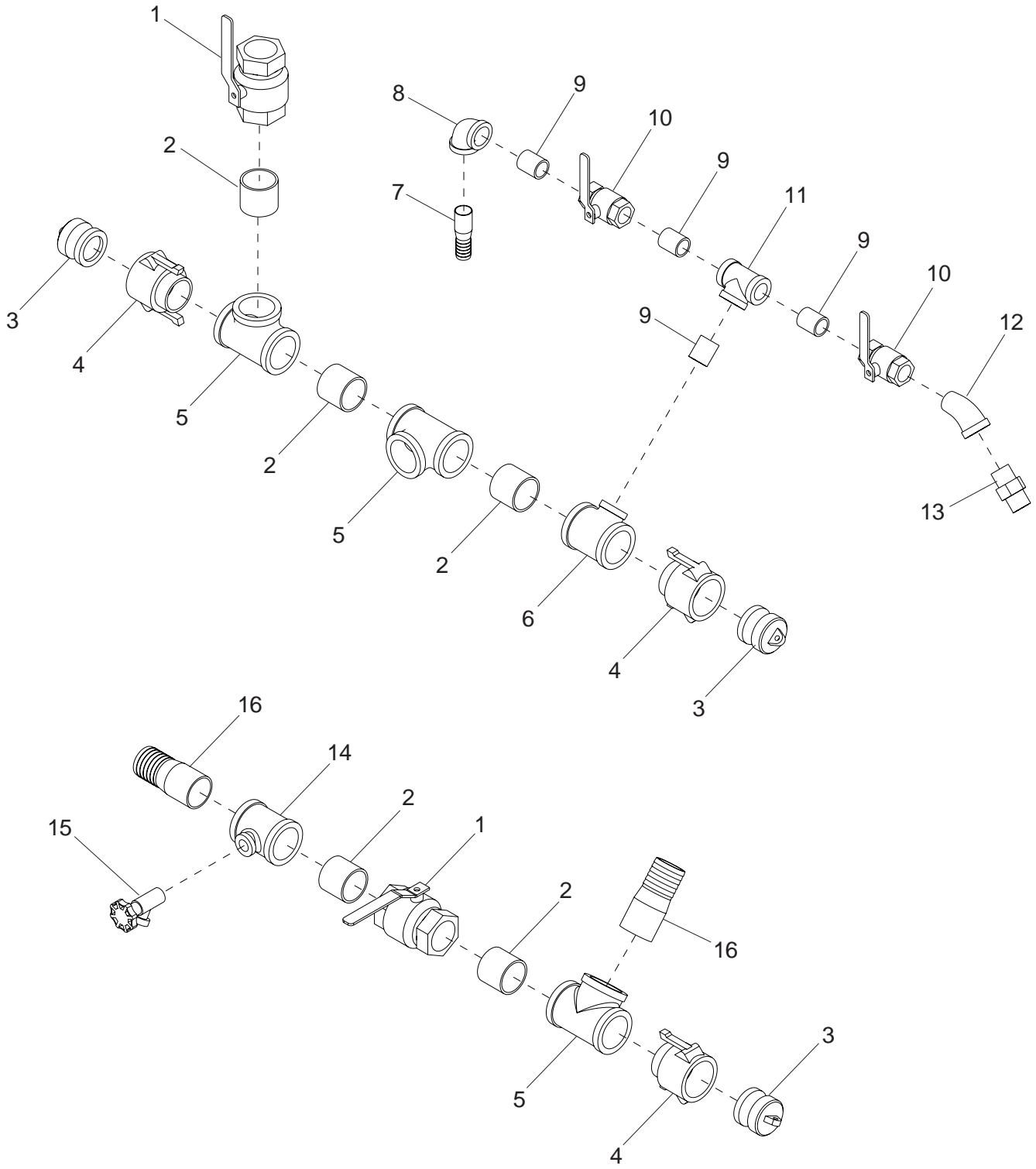

UPPER AND LOWER MANIFOLD ASSEMBLY

ITEM NO.	PART NO.	QTY	DESCRIPTION
1	40229	2	Valve, ball - 2.00NPT
2	21127	5	Nipple, pipe 2"NPT x 2.00
3	40225	3	Fitting, 2.00 plug for female coupler
4	40223	3	Fitting, 2" MNPT x 2" female coupler
5	40330	2	Fitting, tee 2" NPT x 2" NPT
6	40228	1	Fitting, tee 2" NPT x 1" NPT
7	21451	1	Fitting, 1" NPT x 1" barb
8	40814	1	Fitting, 1.00 NPT 90 elbow
9	40276	5	Nipple, pipe 1" NPT
10	40230	2	Valve, ball - 1.00NPT
11	40231	1	Fitting, T - 1.00 NPT
12	40794	1	Fitting, 1.00NPT 45 deg street elbow
13	40798	1	Fitting, adapter - 1.00NPT male
14	40227	1	Fitting, tee 2.00NPT x .75NPT
15	40234	1	Fitting, faucet - .75NPT
16	40222	2	Fitting, 2.00MNPT x 2.00 hose shank

FILL HOSE ASSEMBLY

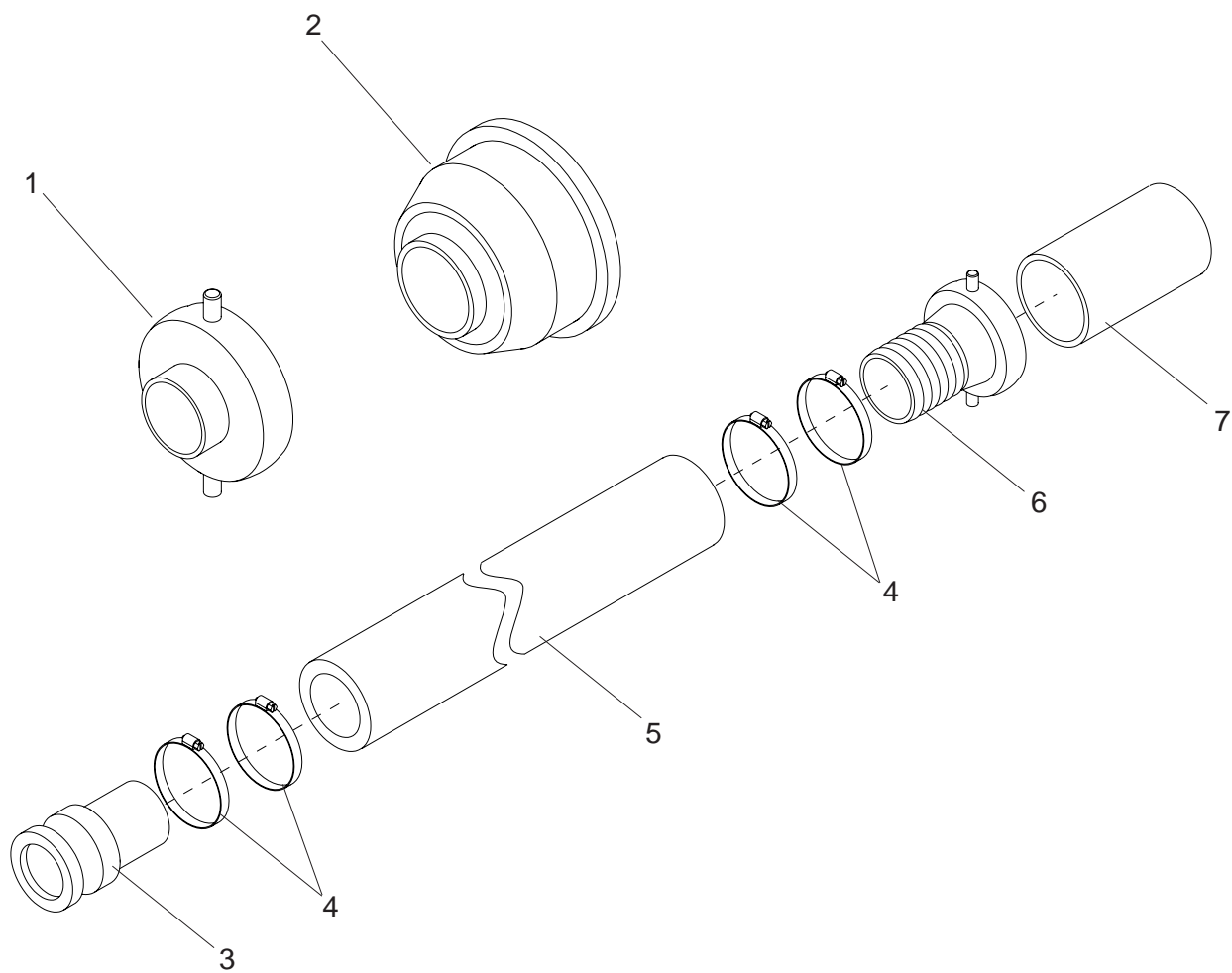

FILL HOSE ASSEMBLY

ITEM NO.	PART NO.	QTY	DESCRIPTION
1	40474	1	Fitting, 2.00 MNPT X 2.50 hydrant
2	40266	1	Strainer, 2"
3	40224	1	Fitting, 2" barb to 2" male adaptor
4	60316	4	Clamp, hose
5	40502	1	Hose, water 2.00 x 20ft
6	40265	1	Fitting, 2" female swivel x 2" barb
7	40475	1	Nipple, pipe 2" NPT x 2 1/2" PVC

DISCHARGE HOSE ASSEMBLIES

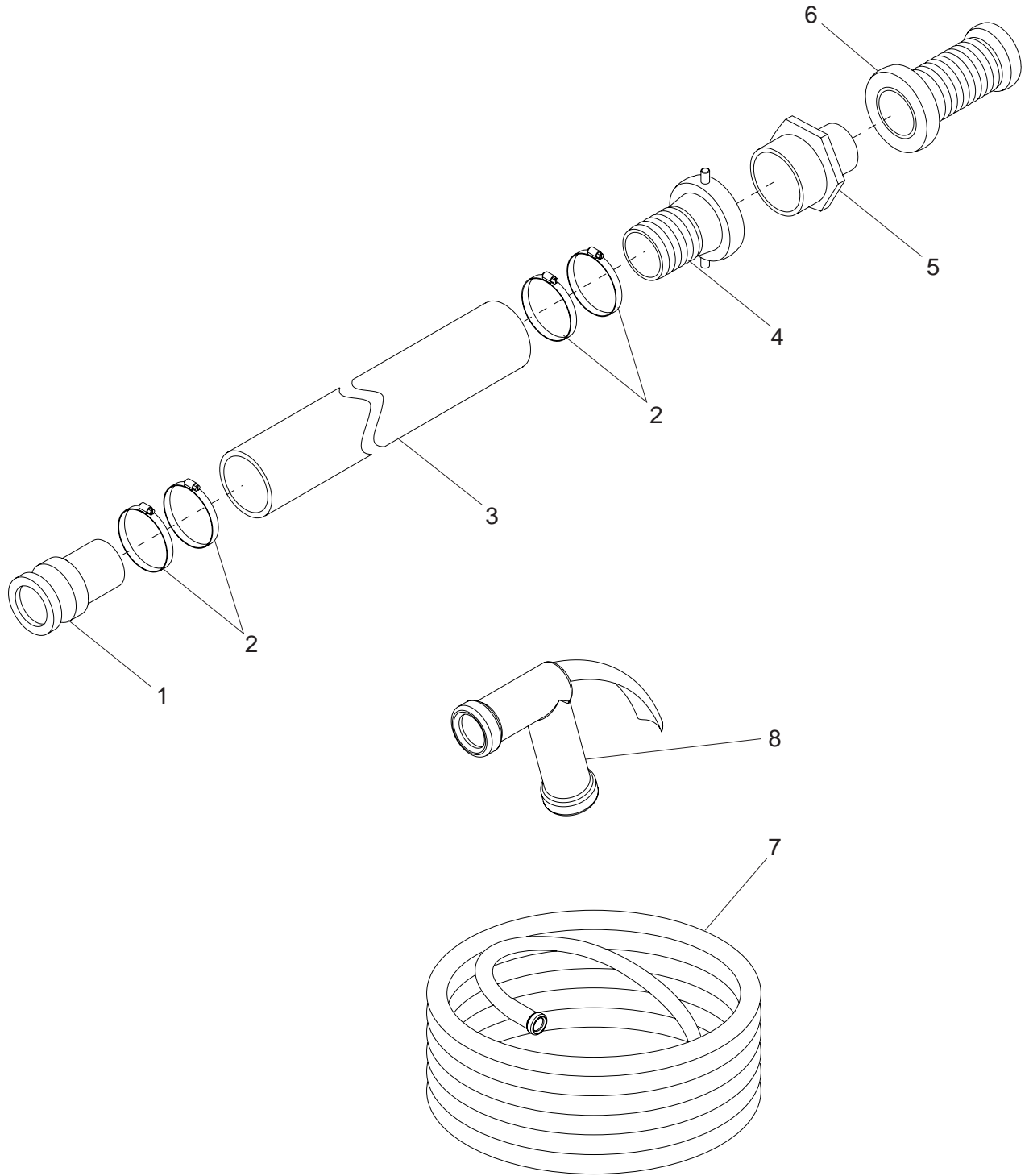

DISCHARGE HOSE ASSEMBLIES

ITEM NO.	PART NO.	QTY	DESCRIPTION
1	40224	1	Fitting, 2.00 hose shank X 2.00 male
2	60316	4	Clamp, hose
3	40505	1	Hose, water 2.00 x 25ft MWT
4	40265	1	Fitting, 2.00 female swivel x 2.00
5	40267	1	Fitting, reducer 2.00 MNPT x 1.50 NPT
6	40257	1	Nozzle, water adjustable spray
7	40800	1	Hose, .625 x 50ft garden
8	40256	1	Nozzle, water - garden hose

REV: D
PART NO: 40859
8.30.06