

MAGNUM WATER TRAILER

ADVANCED FEATURES:

- 4 HP, 4-STROKE ENGINE
- TSURUMI®, 2" CENTRIFUGAL PUMP, 137GPM
- REVERSIBLE FENDER MOUNTED HOSE STORAGE BIN
- GALVANIZED STEEL MANIFOLD, BRASS VALVES AND HOSE BIBBS



Magnum Water Trailers are maneuverable and portable. Their size makes them much more efficient than traditional water trucks. They are used to control construction site dust, support cement cutting, landscaping and trenching activities. Our unparalleled customer service/technical support teams and heavy-duty equipment is what gives our customers the ultimate "return on investment."

Tough

- 2 ⁵/₁₆" ball or 3" pintle ring with adjustable hitch height
- Galvanized steel manifold, brass valves and hose bibbs
- Steel fenders with side skirts
- Full length & width tank support
- Steel manifold support

Reliable

- All components exposed to water are either galvanized steel, powder coated steel, zinc, aluminum, brass, PVC, rubber, or polyethylene
- Honda® 4HP, 4-stroke engine with oil alert® and auto decompression
- Tsurumi® centrifugal pump, 2" suction and discharge
- One year, unlimited hour warranty

Easy to Use

- All operator controls operable from driver's side
- Reversible fender mounted hose storage bin & secure hose adapter storage
- Water fill and dispense performed simply by turning valves, no hose changing required!
- Adjustable hitch heights
- Multiple fill options (hydrant, pond, hose)
- Fire hose connections available from either side of the trailer
- Detailed pictorial operation instructions



For more information:

Call: 1-800-926-9768 Fax: 920-361-2214 Or visit: www.M-P-LLC.com

EMPOWERING REAL PEOPLE

215 POWER DRIVE BERLIN, WISCONSIN 54923-2420
™ TRADEMARK AND ® REGISTERED TRADEMARK OF MAGNUM PRODUCTS LLC



SPECIFICATIONS

Engine:	Honda®, 4HP, 4-stroke, automatic decompression and oil alert®	
Pump:	Tsurumi®, 2" centrifugal pump, capacity: 137GPM	
Water Delivery:	Pressurized 2" flexible fire hose 5/8" pressurized garden hose Pressurized navy brass rear spray nozzles Pump protected from over pressure cracking	Water Fill: Municipal hydrant Pressurized 2" rigid fill hose Suction hose strainer Ponds or other bodies of water
Adapters & Hoses:	20', 2" rigid suction hose with strainer 25', 2" spray hose with spray nozzle 50', 5/8" garden hose with spray nozzle Fender mounted, reversible hose bin Hydrant adapter Spray nozzle	
Tank:	3/8" thick, 500 gallon polyethylene tank Recessed, full length tank support 4" wide tank hold down strap	
Trailer & Frame:	4" steel structural channel frame Large deck for tank access or optional equipment 3" x 4" tubular steel tongue 2 5/16" ball or 3" pintle ring adjustable height hitch DOT approved lights 2000# capacity tongue jack Safety tow chains with hooks Hydraulic surge or electric brakes Tandem #3500 axles 6 bolt wheels 225/75R15 load range D tires Bolt-on steel fenders with side skirts Full width rear bumper Powder coat finish Approximate dry weight – 1,800 lbs. empty Approximate wet weight – 5,800 lbs. fully loaded Dimensions – 160" x 77" x 64" (l x w x h)	

Other Options:

- 10' or 20' rigid suction hose with couplings
- 25', 50' or 75' of 2" spray hose with couplings

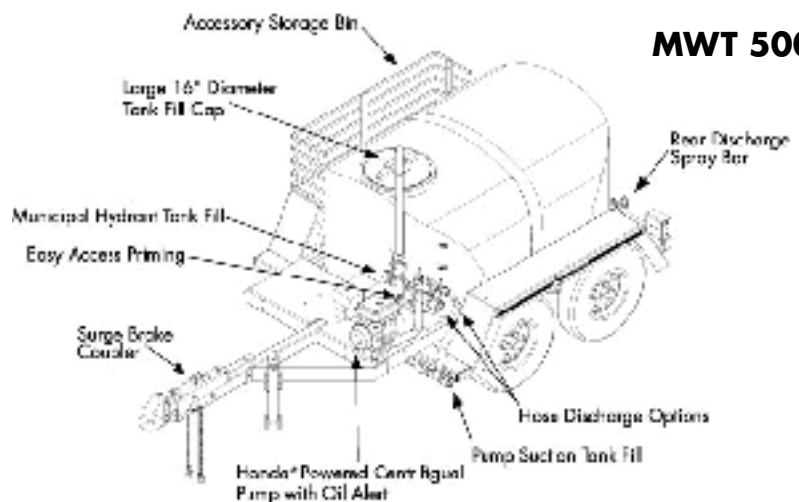

MWT 500

For more information:

Call: 1-800-926-9768 Fax: 920-361-2214 Or visit: www.M-P-LLC.com

SPECIFICATIONS SUBJECT TO CHANGE
 CONTACT YOUR REPRESENTATIVE FOR DETAILS

